

**FQM1 Series**

FQM1-CM001

FQM1-MMP21

FQM1-MMA21

**Flexible Motion Controller**

**OPERATION MANUAL**

**OMRON**

# **FQM1 Series**

**FQM1-CM001**

**FQM1-MMP21**

**FQM1-MMA21**

**Flexible Motion Controller**

**Operation Manual**

*Produced December 2004*

## ***Read and Understand this Manual***

Please read and understand this manual before using the product. Please consult your OMRON representative if you have any questions or comments.

## ***Warranty and Limitations of Liability***

### ***WARRANTY***

OMRON's exclusive warranty is that the products are free from defects in materials and workmanship for a period of one year (or other period if specified) from date of sale by OMRON.

OMRON MAKES NO WARRANTY OR REPRESENTATION, EXPRESS OR IMPLIED, REGARDING NON-INFRINGEMENT, MERCHANTABILITY, OR FITNESS FOR PARTICULAR PURPOSE OF THE PRODUCTS. ANY BUYER OR USER ACKNOWLEDGES THAT THE BUYER OR USER ALONE HAS DETERMINED THAT THE PRODUCTS WILL SUITABLY MEET THE REQUIREMENTS OF THEIR INTENDED USE. OMRON DISCLAIMS ALL OTHER WARRANTIES, EXPRESS OR IMPLIED.

### ***LIMITATIONS OF LIABILITY***

OMRON SHALL NOT BE RESPONSIBLE FOR SPECIAL, INDIRECT, OR CONSEQUENTIAL DAMAGES, LOSS OF PROFITS OR COMMERCIAL LOSS IN ANY WAY CONNECTED WITH THE PRODUCTS, WHETHER SUCH CLAIM IS BASED ON CONTRACT, WARRANTY, NEGLIGENCE, OR STRICT LIABILITY.

In no event shall the responsibility of OMRON for any act exceed the individual price of the product on which liability is asserted.

IN NO EVENT SHALL OMRON BE RESPONSIBLE FOR WARRANTY, REPAIR, OR OTHER CLAIMS REGARDING THE PRODUCTS UNLESS OMRON'S ANALYSIS CONFIRMS THAT THE PRODUCTS WERE PROPERLY HANDLED, STORED, INSTALLED, AND MAINTAINED AND NOT SUBJECT TO CONTAMINATION, ABUSE, MISUSE, OR INAPPROPRIATE MODIFICATION OR REPAIR.

## ***Application Considerations***

### ***SUITABILITY FOR USE***

OMRON shall not be responsible for conformity with any standards, codes, or regulations that apply to the combination of products in the customer's application or use of the products.

At the customer's request, OMRON will provide applicable third party certification documents identifying ratings and limitations of use that apply to the products. This information by itself is not sufficient for a complete determination of the suitability of the products in combination with the end product, machine, system, or other application or use.

The following are some examples of applications for which particular attention must be given. This is not intended to be an exhaustive list of all possible uses of the products, nor is it intended to imply that the uses listed may be suitable for the products:

- Outdoor use, uses involving potential chemical contamination or electrical interference, or conditions or uses not described in this manual.
- Nuclear energy control systems, combustion systems, railroad systems, aviation systems, medical equipment, amusement machines, vehicles, safety equipment, and installations subject to separate industry or government regulations.
- Systems, machines, and equipment that could present a risk to life or property.

Please know and observe all prohibitions of use applicable to the products.

**NEVER USE THE PRODUCTS FOR AN APPLICATION INVOLVING SERIOUS RISK TO LIFE OR PROPERTY WITHOUT ENSURING THAT THE SYSTEM AS A WHOLE HAS BEEN DESIGNED TO ADDRESS THE RISKS, AND THAT THE OMRON PRODUCTS ARE PROPERLY RATED AND INSTALLED FOR THE INTENDED USE WITHIN THE OVERALL EQUIPMENT OR SYSTEM.**

### ***PROGRAMMABLE PRODUCTS***

OMRON shall not be responsible for the user's programming of a programmable product, or any consequence thereof.

## ***Disclaimers***

### ***CHANGE IN SPECIFICATIONS***

Product specifications and accessories may be changed at any time based on improvements and other reasons.

It is our practice to change model numbers when published ratings or features are changed, or when significant construction changes are made. However, some specifications of the products may be changed without any notice. When in doubt, special model numbers may be assigned to fix or establish key specifications for your application on your request. Please consult with your OMRON representative at any time to confirm actual specifications of purchased products.

### ***DIMENSIONS AND WEIGHTS***

Dimensions and weights are nominal and are not to be used for manufacturing purposes, even when tolerances are shown.

### ***PERFORMANCE DATA***

Performance data given in this manual is provided as a guide for the user in determining suitability and does not constitute a warranty. It may represent the result of OMRON's test conditions, and the users must correlate it to actual application requirements. Actual performance is subject to the OMRON Warranty and Limitations of Liability.

### ***ERRORS AND OMISSIONS***



The information in this manual has been carefully checked and is believed to be accurate; however, no responsibility is assumed for clerical, typographical, or proofreading errors, or omissions.



## **Notice:**

OMRON products are manufactured for use according to proper procedures by a qualified operator and only for the purposes described in this manual.

The following conventions are used to indicate and classify precautions in this manual. Always heed the information provided with them. Failure to heed precautions can result in injury to people or damage to property.

-  **DANGER** Indicates an imminently hazardous situation which, if not avoided, will result in death or serious injury. Additionally, there may be severe property damage.
-  **WARNING** Indicates a potentially hazardous situation which, if not avoided, could result in death or serious injury. Additionally, there may be severe property damage.
-  **Caution** Indicates a potentially hazardous situation which, if not avoided, may result in minor or moderate injury, or property damage.

## **OMRON Product References**

All OMRON products are capitalized in this manual. The word “Unit” is also capitalized when it refers to an OMRON product, regardless of whether or not it appears in the proper name of the product.

The abbreviation “Ch,” which appears in some displays and on some OMRON products, often means “word” and is abbreviated “Wd” in documentation in this sense.

The abbreviation “CM” means Coordinator Module and the abbreviation “MM” means Motion Control Module.

## **Visual Aids**

The following headings appear in the left column of the manual to help you locate different types of information.

**Note** Indicates information of particular interest for efficient and convenient operation of the product.

- 1,2,3...** 1. Indicates lists of one sort or another, such as procedures, checklists, etc.

### **© OMRON, 2004**

All rights reserved. No part of this publication may be reproduced, stored in a retrieval system, or transmitted, in any form, or by any means, mechanical, electronic, photocopying, recording, or otherwise, without the prior written permission of OMRON.

No patent liability is assumed with respect to the use of the information contained herein. Moreover, because OMRON is constantly striving to improve its high-quality products, the information contained in this manual is subject to change without notice. Every precaution has been taken in the preparation of this manual. Nevertheless, OMRON assumes no responsibility for errors or omissions. Neither is any liability assumed for damages resulting from the use of the information contained in this publication.





# TABLE OF CONTENTS

<b>PRECAUTIONS</b> .....	<b>xiii</b>
1 Intended Audience .....	xiv
2 General Precautions .....	xiv
3 Safety Precautions .....	xiv
4 Conformance to EC Directives .....	xix
5 Data Backup .....	xxii
<b>SECTION 1</b>	
<b>Features and System Configuration</b> .....	<b>1</b>
1-1 Outline of FQM1 Flexible Motion Controller .....	2
1-2 FQM1 Configuration .....	4
1-3 Modules .....	6
1-4 CX-Programmer .....	8
1-5 Expanded System Configuration .....	9
1-6 Basic Operating Procedure .....	13
1-7 Function Tables Arranged by Purpose .....	19
<b>SECTION 2</b>	
<b>Specifications and Nomenclature</b> .....	<b>31</b>
2-1 List of Models .....	32
2-2 General Specifications .....	32
2-3 Coordinator Module .....	34
2-4 Motion Control Modules .....	37
2-5 Dimensions .....	43
2-6 Module Current Consumption .....	45
2-7 Memory Block Diagram .....	47
<b>SECTION 3</b>	
<b>Installation and Wiring</b> .....	<b>49</b>
3-1 Installation .....	50
3-2 Wiring .....	60
3-3 Wiring Module Connectors .....	67
3-4 Wiring Servo Relay Units .....	75
3-5 List of FQM1 Connecting Cables .....	83
3-6 Wiring Precautions .....	85
<b>SECTION 4</b>	
<b>Operation</b> .....	<b>91</b>
4-1 Coordinator Module .....	92
4-2 Motion Control Modules .....	95
4-3 Operating Modes .....	99
4-4 Power OFF Operation .....	100

# TABLE OF CONTENTS

## SECTION 5

### **Module Functions and Data Exchange . . . . . 103**

5-1	Synchronous Operation between Modules . . . . .	104
5-2	Data Exchange between Modules . . . . .	105
5-3	Cyclic Refresh . . . . .	106
5-4	Synchronous Data Refresh . . . . .	109
5-5	DM Data Transfer . . . . .	112
5-6	Cycle Time Settings . . . . .	114
5-7	Operation Settings at Startup and Maintenance Functions . . . . .	118
5-8	Diagnostic Functions . . . . .	120

## SECTION 6

### **Coordinator Module Functions . . . . . 123**

6-1	Serial Communications . . . . .	124
-----	---------------------------------	-----

## SECTION 7

### **Motion Control Module Functions . . . . . 137**

7-1	Overview . . . . .	139
7-2	Interrupt Functions . . . . .	140
7-3	Input Interrupts . . . . .	142
7-4	Interval Timer Interrupts . . . . .	146
7-5	Pulse Inputs . . . . .	148
7-6	Pulse Outputs . . . . .	167
7-7	Functions for Servo Drivers Compatible with Absolute Encoders . . . . .	199
7-8	Virtual Pulse Output Function . . . . .	212
7-9	Analog Input Functions . . . . .	215
7-10	Analog Outputs . . . . .	225

## SECTION 8

### **Connecting the CX-Programmer . . . . . 231**

8-1	CX-Programmer . . . . .	232
8-2	Connecting the CX-Programmer . . . . .	233

## SECTION 9

### **Error Processing . . . . . 239**

9-1	Error Log . . . . .	240
9-2	Error Processing . . . . .	241
9-3	Troubleshooting Problems in Modules . . . . .	254

# TABLE OF CONTENTS

## SECTION 10

<b>Inspection and Maintenance</b> .....	<b>257</b>
---	------------

10-1 Inspections .....	258
------------------------	-----

## Appendices

A Programming .....	261
---------------------	-----

B I/O Memory .....	297
--------------------	-----

C System Setup, Auxiliary Area Allocations, and Built-in I/O Allocations .....	309
--	-----

D Auxiliary Area Allocations .....	347
------------------------------------	-----

<b>Index</b> .....	<b>373</b>
--------------------	------------

<b>Revision History</b> .....	<b>385</b>
-------------------------------	------------

# TABLE OF CONTENTS

## About this Manual:

This manual describes the operation of the Coordinator Module and Motion Control Modules of the FQM1-series Flexible Motion Controller.

Please read this manual and all related manuals listed in the table below and be sure you understand information provided before attempting to program or use FQM1-series Flexible Motion Controllers in a control system.

Name	Cat. No.	Contents
FQM1 Series FQM1-CM001, FQM1-MMP21, FQM1-MMA21 Flexible Motion Controller Operation Manual (this manual)	O010	This manual provides an overview of and describes the following information for the FQM1-series Flexible Motion Controller: features, system configuration, system design, installation, wiring, maintenance, I/O memory allocation, troubleshooting, etc.
FQM1 Series FQM1-CM001, FQM1-MMP21, FQM1-MMA21 Flexible Motion Controller Instructions Reference Manual	O011	Describes the ladder diagram programming instructions supported by FQM1-series Flexible Motion Controller. Use this manual together with the <i>Operation Manual</i> (Cat. No. O010).
SYSMAC WS02-CXP□□-E CX-Programmer Operation Manual Version 5.□	W437	Provides information on how to use the CX-Programmer, a Windows-based programming and monitoring package for OMRON PLCs.

**Section 1** describes the features of the FQM1 and its system configuration.

**Section 2** provides the specifications of the FQM1 and describes the parts and their functions on the Coordinator Module and Motion Control Modules.

**Section 3** describes how to install and wire the FQM1

**Section 4** describes the operation of the FQM1.

**Section 5** describes the functions common to both the Coordinator Module and Motion Control Modules and the methods to transfer data between the Coordinator Module and Motion Control Modules.

**Section 6** describes the serial communications functions, which are supported only by the Coordinator Module.

**Section 7** describes the various functions supported by the Motion Control Module.

**Section 8** explains how to connect a personal computer running the CX-Programmer to the FQM1.

**Section 9** provides information on identifying and correcting errors that occur during FQM1 operation.

**Section 10** provides inspection and maintenance information.

The **Appendices** provide information on programming, I/O Memory, System Setup, and built-in I/O allocations, and Auxiliary Area allocations.



# PRECAUTIONS

This section provides general precautions for using the FQM1-series Flexible Motion Controller and related devices.

**The information contained in this section is important for the safe and reliable application of the FQM1-series Flexible Motion Controller. You must read this section and understand the information contained before attempting to set up or operate a control system using the FQM1-series Flexible Motion Controller.**

1	Intended Audience .....	xiv
2	General Precautions .....	xiv
3	Safety Precautions.....	xiv
3-1	Operating Environment Precautions.....	xv
3-2	Application Precautions .....	xvi
4	Conformance to EC Directives .....	xix
4-1	Applicable Directives .....	xix
4-2	Concepts .....	xix
4-3	Conformance to EC Directives.....	xix
4-4	EMC Directive Conformance Conditions.....	xix
4-5	Relay Output Noise Reduction Methods .....	xx
5	Data Backup .....	xxii

## 1 Intended Audience

This manual is intended for the following personnel, who must also have knowledge of electrical systems (an electrical engineer or the equivalent).

- Personnel in charge of installing FA systems.
- Personnel in charge of designing FA systems.
- Personnel in charge of managing FA systems and facilities.

## 2 General Precautions

The user must operate the product according to the performance specifications described in the operation manuals.

Before using the product under conditions which are not described in the manual or applying the product to nuclear control systems, railroad systems, aviation systems, vehicles, combustion systems, medical equipment, amusement machines, safety equipment, petrochemical plants, and other systems, machines, and equipment that may have a serious influence on lives and property if used improperly, consult your OMRON representative.

Make sure that the ratings and performance characteristics of the product are sufficient for the systems, machines, and equipment, and be sure to provide the systems, machines, and equipment with double safety mechanisms.

 **WARNING** It is extremely important that the FQM1 be used for the specified purpose and under the specified conditions, especially in applications that can directly or indirectly affect human life. You must consult with your OMRON representative before applying an FQM1 System to the above-mentioned applications.

## 3 Safety Precautions

 **WARNING** Do not attempt to take any Modules apart while the power is being supplied. Doing so may result in electric shock.

 **WARNING** Do not touch any of the terminals or terminal blocks while the power is being supplied. Doing so may result in electric shock.

 **WARNING** Do not attempt to disassemble, repair, or modify any Modules. Any attempt to do so may result in malfunction, fire, or electric shock.

 **WARNING** Provide safety measures in external circuits, i.e., not in the Flexible Motion Controller (referred to as the “FQM1”), to ensure safety in the system if an abnormality occurs due to malfunction of the FQM1 or another external factor affecting the FQM1 operation. Not doing so may result in serious accidents.

- Emergency stop circuits, interlock circuits, limit circuits, and similar safety measures must be provided in external control circuits.
- The FQM1 will turn OFF all outputs when its self-diagnosis function detects any error or when a severe failure alarm (FALS) instruction is executed. As a countermeasure for such errors, external safety measures must be provided to ensure safety in the system.
- The FQM1 outputs may remain ON or OFF due to destruction of the output transistors. As a countermeasure for such problems, external safety measures must be provided to ensure safety in the system.



- When the 24-VDC output (service power supply to the FQM1) is overloaded or short-circuited, the voltage may drop and result in the outputs being turned OFF. As a countermeasure for such problems, external safety measures must be provided to ensure safety in the system.

- ⚠ WARNING** Fail-safe measures must be taken by the customer to ensure safety in the event of incorrect, missing, or abnormal signals caused by broken signal lines, momentary power interruptions, or other causes. Not doing so may result in serious accidents.
- ⚠ Caution** Execute online edit only after confirming that no adverse effects will be caused by extending the cycle time. Otherwise, the input signals may not be readable.
- ⚠ Caution** User programs and parameters written to the Coordinator Module or Motion Control Module will be automatically backed up in the FQM1 flash memory (flash memory function). The contents of I/O memory (including the DM Area), however, are not written to flash memory. Part of the DM Area used as a holding area when recovering from a power interruption is backed up using a super capacitor, but correct values will not be maintained if an error occurs that prevents memory backup. As a countermeasure for such problems, take appropriate measures in the program using the Memory Not Held Flag (A404.14) when externally outputting the contents of the DM Area.
- ⚠ Caution** Confirm safety at the destination Module before transferring a program to another Module or editing the I/O area. Doing either of these without confirming safety may result in injury.
- ⚠ Caution** Tighten the screws on the terminal block of the AC Power Supply Unit to the torque specified in the operation manual. The loose screws may result in burning or malfunction.
- ⚠ Caution** Do not touch the Power Supply Unit while the power is ON, and immediately after turning OFF the power. Touching hot surfaces may result in burning.
- ⚠ Caution** Pay careful attention to the polarities (+/-) when wiring the DC power supply. A wrong connection may cause malfunction of the system.

## 3-1 Operating Environment Precautions

- ⚠ Caution** Do not operate the control system in the following places:
- Locations subject to direct sunlight
  - Locations subject to temperatures or humidity outside the range specified in the specifications
  - Locations subject to condensation as the result of severe changes in temperature
  - Locations subject to corrosive or flammable gases
  - Locations subject to dust (especially iron dust) or salts
  - Locations subject to exposure to water, oil, or chemicals
  - Locations subject to shock or vibration
- ⚠ Caution** Take appropriate and sufficient countermeasures when installing systems in the following locations:

- Locations subject to static electricity or other forms of noise
- Locations subject to strong electromagnetic fields
- Locations subject to possible exposure to radioactivity
- Locations close to power supplies

 **Caution** The operating environment of the FQM1 System can have a large effect on the longevity and reliability of the system. Improper operating environments can lead to malfunction, failure, and other unforeseeable problems with the FQM1 System. Make sure that the operating environment is within the specified conditions at installation and remains within the specified conditions during the life of the system.

## 3-2 Application Precautions

 **WARNING** Always heed these precautions. Failure to abide by the following precautions could lead to serious or possibly fatal injury.

- Always connect to a ground of 100  $\Omega$  or less when installing the FQM1. Not doing so may result in electric shock.
- Always connect to a ground of 100  $\Omega$  or less when short-circuiting the functional ground and line ground terminals of the Power Supply Unit, in particular.
- Always turn OFF the power supply to the FQM1 before attempting any of the following. Not turning OFF the power supply may result in malfunction or electric shock.
  - Mounting or dismounting Power Supply Unit, Coordinator Module, Motion Control Module, and End Module
  - Assembling the Modules
  - Setting DIP switches
  - Connecting or wiring the cables
  - Connecting or disconnecting the connectors

 **Caution** Failure to abide by the following precautions could lead to faulty operation of the FQM1 or the system, or could damage the FQM1. Always heed these precautions.

- Always use the CX-Programmer (Programming Device for Windows) to create new cyclic tasks and interrupt tasks.
- The user program and parameter area data in Coordinator Module and Motion Control Modules is backed up in the built-in flash memory. Do not turn OFF the power supply to the FQM1 while the user program or parameter area data is being transferred. The data will not be backed up if the power is turned OFF.
- The FQM1 will start operating in RUN mode when the power is turned ON with the default settings (i.e., if the operating mode at power ON (startup mode) setting in the System Setup is disabled).
- Configure the external circuits so that the control power supply turns ON after the power supply to the FQM1 turns ON. If the power is turned ON in the opposite order, the built-in outputs and other outputs may momentarily malfunction and the control outputs may temporarily not operate correctly.

- Outputs may remain ON due to a malfunction in the built-in transistor outputs or other internal circuits. As a countermeasure for such problems, external safety measures must be provided to ensure the safety of the system.
- Part of the DM Area (data memory) in the Motion Control Module is held using the super capacitor. Corrupted memory may prevent the correct values from being saved, however. Take appropriate measures in the ladder program whenever the Memory Not Held Flag (A404.14) turns ON, such as resetting the data in the DM Area.
- Part of the DM Area in the Coordinator Module is backed up in the built-in flash memory when transferring data from the CX-Programmer. Do not turn OFF the power to the FQM1 while data is being transferred. The data will not be backed up if the power is turned OFF.
- Confirm that no adverse effect will occur in the system before attempting any of the following. Not doing so may result in an unexpected operation.
  - Changing the operating mode of the FQM1
  - Force-setting/force-resetting any bit in memory
  - Changing the present value of any word or any set value in memory
- Install external breakers and take other safety measures against short-circuiting in external wiring. Insufficient safety measures against short-circuiting may result in burning.
- Be sure that all the terminal screws and cable connector screws are tightened to the torque specified in the relevant manuals. Incorrect tightening torque may result in malfunction.
- Mount the Modules only after checking the connectors and terminal blocks completely.
- Before touching the Module, be sure to first touch a grounded metallic object in order to discharge any static built-up. Not doing so may result in malfunction or damage.
- Be sure that the terminal blocks, connectors, and other items with locking devices are properly locked into place. Improper locking may result in malfunction.
- Wire correctly according to the specified procedures.
- Always use the power supply voltage specified in the operation manuals. An incorrect voltage may result in malfunction or burning.
- Take appropriate measures to ensure that the specified power with the rated voltage and frequency is supplied. Be particularly careful in places where the power supply is unstable. An incorrect power supply may result in malfunction.
- Leave the dust protective label attached to the Module when wiring. Removing the label may result in malfunction.
- Remove the dust protective label after the completion of wiring to ensure proper heat dissipation. Leaving the label attached may result in malfunction.
- Use crimp terminals for wiring. Do not connect bare stranded wires directly to terminals. Connection of bare stranded wires may result in burning.
- Do not apply voltages to the built-in inputs in excess of the rated input voltage. Excess voltages may result in burning.

- Do not apply voltages or connect loads to the built-in outputs in excess of the maximum switching capacity. Excess voltage or loads may result in burning.
- Disconnect the functional ground terminal when performing withstand voltage tests. Not disconnecting the functional ground terminal may result in burning.
- Wire correctly and double-check all the wiring or the setting switches before turning ON the power supply. Incorrect wiring may result in burning.
- Check that the DIP switches and data memory (DM) are properly set before starting operation.
- Check the user program for proper execution before actually running it on the Module. Not checking the program may result in an unexpected operation.
- Resume operation only after transferring to the new Module the contents of the DM Areas, programs, parameters, and data required for resuming operation. Not doing so may result in an unexpected operation.
- Do not pull on the cables or bend the cables beyond their natural limit. Doing either of these may break the cables.
- Do not place objects on top of the cables. Doing so may break the cables.
- Use the dedicated connecting cables specified in operation manuals to connect the Modules. Using commercially available RS-232C computer cables may cause failures in external devices or the Coordinator Module.
- Do not connect pin 6 (+5V) on the RS-232C port on the Coordinator Module to any external device other than the NT-AL001 or CJ1W-CIF11 Conversion Adapter. Doing so may result in damage to the external device and the Coordinator Module.
- When replacing parts, be sure to confirm that the rating of a new part is correct. Not doing so may result in malfunction or burning.
- When transporting or storing the product, cover the PCBs with electrically conductive materials to prevent LSIs and ICs from being damaged by static electricity, and also keep the product within the specified storage temperature range.
- Do not touch the mounted parts or the rear surface of PCBs because PCBs have sharp edges such as electrical leads.
- When connecting the Power Supply Unit, Coordinator Module, Motion Control Module, and End Module, slide the upper and lower sliders until a click sound is heard to lock them securely. Desired functionality may not be achieved unless Modules are securely locked in place.
- Be sure to mount the End Module supplied with the Coordinator Module to the rightmost Module. Unless the End Module is properly mounted, the FQM1 will not function properly.
- Make sure that parameters are set correctly. Incorrect parameter settings may result in unexpected operations. Make sure that equipment will not be adversely affected by the parameter settings before starting or stopping the FQM1.

## 4 Conformance to EC Directives

### 4-1 Applicable Directives

- EMC Directives
- Low Voltage Directive

### 4-2 Concepts

#### **EMC Directives**

OMRON devices that comply with EC Directives also conform to the related EMC standards so that they can be more easily built into other devices or the overall machine. The actual products have been checked for conformity to EMC standards (see the following note). Whether the products conform to the standards in the system used by the customer, however, must be checked by the customer.

EMC-related performance of the OMRON devices that comply with EC Directives will vary depending on the configuration, wiring, and other conditions of the equipment or control panel on which the OMRON devices are installed. The customer must, therefore, perform the final check to confirm that devices and the overall machine conform to EMC standards.

**Note** Applicable EMC (Electromagnetic Compatibility) standards are as follows:

EMS (Electromagnetic Susceptibility): EN61000-6-2  
EMI (Electromagnetic Interference): EN61000-6-4  
(Radiated emission: 10-m regulations)

#### **Low Voltage Directive**

Always ensure that devices operating at voltages of 50 to 1,000 V AC and 75 to 1,500 V DC meet the required safety standards for the Motion Controller (EN61131-2).

### 4-3 Conformance to EC Directives

The FQM1-series Flexible Motion Controllers comply with EC Directives. To ensure that the machine or device in which the Motion Controller is used complies with EC Directives, the Motion Controller must be installed as follows:

- 1,2,3...**
1. The Motion Controller must be installed within a control panel.
  2. You must use reinforced insulation or double insulation for the DC power supplies used for the communications power supply and I/O power supplies.
  3. Motion Controllers complying with EC Directives also conform to the Common Emission Standard (EN61000-6-4). Radiated emission characteristics (10-m regulations) may vary depending on the configuration of the control panel used, other devices connected to the control panel, wiring, and other conditions. You must therefore confirm that the overall machine or equipment complies with EC Directives.

### 4-4 EMC Directive Conformance Conditions

The immunity testing condition of the Motion Control Modules is as follows:

Overall accuracy of FQM1-MMA21 analog I/O: +4%/–2%

## 4-5 Relay Output Noise Reduction Methods

The FQM1-series Flexible Motion Controller conforms to the Common Emission Standards (EN61000-6-4) of the EMC Directives. However, noise generated by relay output switching may not satisfy these Standards. In such a case, a noise filter must be connected to the load side or other appropriate countermeasures must be provided external to the Motion Controller.

Countermeasures taken to satisfy the standards vary depending on the devices on the load side, wiring, configuration of machines, etc. Following are examples of countermeasures for reducing the generated noise.

### Countermeasures

(Refer to EN61000-6-4 for more details.)

Countermeasures are not required if the frequency of load switching for the whole system with the Motion Controller included is less than 5 times per minute.

Countermeasures are required if the frequency of load switching for the whole system with the Motion Controller included is more than 5 times per minute.

### Countermeasure Examples

When switching an inductive load, connect a surge protector, diodes, etc., in parallel with the load or contact as shown below.

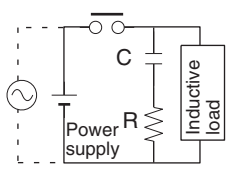
Circuit	Current		Characteristic	Required element
	AC	DC		
<p>CR method</p> 	Yes	Yes	<p>If the load is a relay or solenoid, there is a time lag between the moment the circuit is opened and the moment the load is reset.</p> <p>If the supply voltage is 24 or 48 V, insert the surge protector in parallel with the load. If the supply voltage is 100 to 200 V, insert the surge protector between the contacts.</p>	<p>The capacitance of the capacitor must be 1 to 0.5 <math>\mu\text{F}</math> per contact current of 1 A and resistance of the resistor must be 0.5 to 1 <math>\Omega</math> per contact voltage of 1 V. These values, however, vary with the load and the characteristics of the relay. Decide these values from experiments, and take into consideration that the capacitance suppresses spark discharge when the contacts are separated and the resistance limits the current that flows into the load when the circuit is closed again.</p> <p>The dielectric strength of the capacitor must be 200 to 300 V. If the circuit is an AC circuit, use a capacitor with no polarity.</p>

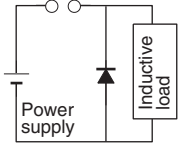
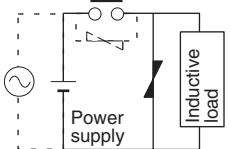
Circuit	Current		Characteristic	Required element
	AC	DC		
<p>Diode method</p> 	No	Yes	<p>The diode connected in parallel with the load changes energy accumulated by the coil into a current, which then flows into the coil so that the current will be converted into Joule heat by the resistance of the inductive load.</p> <p>This time lag, between the moment the circuit is opened and the moment the load is reset, caused by this method is longer than that caused by the CR method.</p>	<p>The reversed dielectric strength value of the diode must be at least 10 times as large as the circuit voltage value. The forward current of the diode must be the same as or larger than the load current.</p> <p>The reversed dielectric strength value of the diode may be two to three times larger than the supply voltage if the surge protector is applied to electronic circuits with low circuit voltages.</p>
<p>Varistor method</p> 	Yes	Yes	<p>The varistor method prevents the imposition of high voltage between the contacts by using the constant voltage characteristic of the varistor. There is time lag between the moment the circuit is opened and the moment the load is reset.</p> <p>If the supply voltage is 24 or 48 V, insert the varistor in parallel with the load. If the supply voltage is 100 to 200 V, insert the varistor between the contacts.</p>	---

When switching a load with a high inrush current such as an incandescent lamp, suppress the inrush current as shown below.

Countermeasure 1

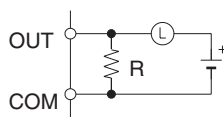

Providing a dark current of approx. one-third of the rated value through an incandescent lamp

Countermeasure 2

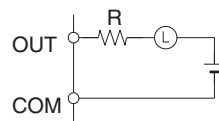

Providing a limiting resistor

The following Unit and Cables can be used with the FQM1-series Flexible Motion Controller.

Name	Model	Cable length
Relay Unit	XW2B-80J7-1A	---
Controller Connecting Cables	XW2Z-050J-A28	0.5 m
	XW2Z-100J-A28	1 m
	XW2Z-050J-A30	0.5 m
	XW2Z-100J-A30	1 m
	XW2Z-050J-A31	0.5 m
	XW2Z-100J-A31	1 m

## 5 Data Backup

The user programs, I/O memories, and other data in the Coordinator Module and Motion Control Modules is backed up either by a super capacitor or flash memory, as listed in the following table.

Module	Data	Data backup
Coordinator Module	Error log	RAM with super capacitor
Motion Control Module	DM Area words D30000 to D32767 Error log	
Coordinator Module	User program System Setup DM Area words D30000 to D32767	Flash memory
Motion Control Module	User program System Setup	

The data backup time of the super capacitor is given in the following table and shown in the following graph.

Temperature	Initial	After 5 years	After 10 years
Ta = 25°C	101.61 hours (4.23 days)	96.2 hours (4.01 days)	90.8 hours (3.78 days)
Ta = 40°C	26.39 hours (1.09 days)	15.28 hours	4.16 hours

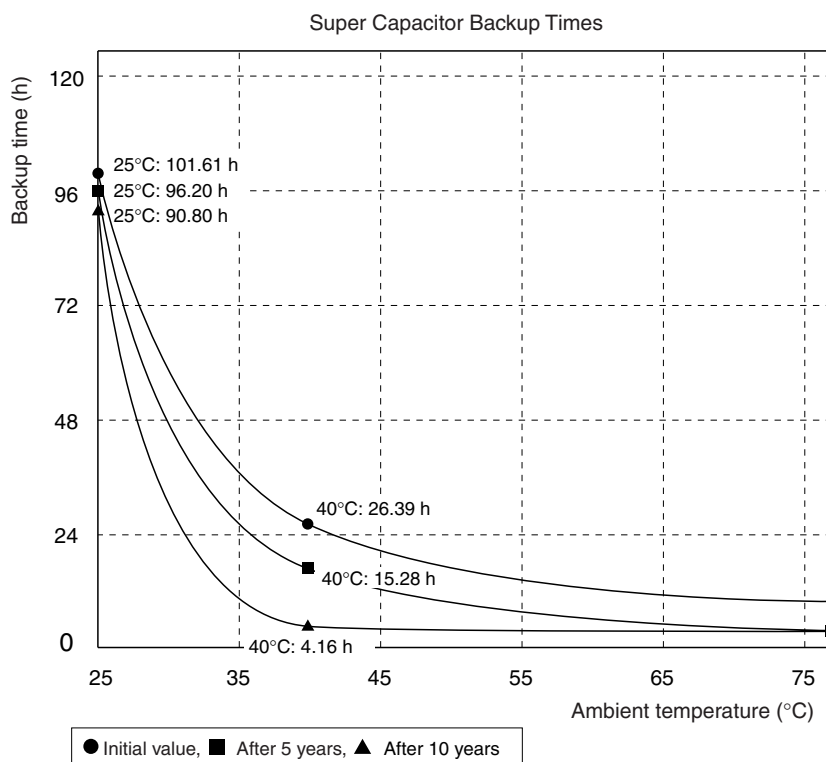

- Note
1. The times give above assume that the capacitor is completely charged. Power must be supply to the FQM1 for at least 20 minutes to completely charge the capacitor.
  2. The backup time of the super capacitor is reduced as the capacitor ages. It is also affected by the ambient temperature. Use portion of the DM Area backed up by the super capacitor only for data that is to be held during mo-



mentary power interruptions. For operating parameters and other long-term data, use the portion of DM Area stored in flash memory in the Coordinator Module and transfer it to the Motion Control Modules before starting operation.

The data in the DM Area and error log will become unstable or corrupted if the power to the system is OFF for longer than the backup time.

If the power supply is to be turned OFF for an extended period of time, use D30000 to D32767 in the Coordinator Module, which is backed up in flash memory, to store data.

Otherwise, the Memory Not Held Flag (A404.14) can be used as the input condition for programming using data in areas stored for power interruptions to perform suitable processing.

A404.14: Turns ON when power is turned ON if data stored for power interruptions in the DM Area or error log is corrupted.

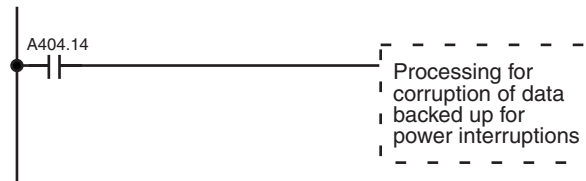

DM Area words D30000 to D32767 in the Coordinator Module are backed up in flash memory as described in the next section.

### **Backing Up DM Area Data in Flash Memory**

DM Area words D30000 to D32767 in the Coordinator Module is read from flash memory when the power supply is turned ON. We recommend using DM Area words D30000 to D32767 in the Coordinator Module to store operating parameters and other data required for system operation and then using the DM transfer function to transfer the data from the Coordinator Module to the Motion Control Modules at the start of operation.



# SECTION 1

## Features and System Configuration

This section describes the features of the FQM1 and its system configuration.

1-1	Outline of FQM1 Flexible Motion Controller .....	2
1-2	FQM1 Configuration.....	4
1-3	Modules.....	6
1-4	CX-Programmer .....	8
1-5	Expanded System Configuration.....	9
1-5-1	Serial Communications.....	9
1-5-2	Systems.....	9
1-6	Basic Operating Procedure .....	13
1-6-1	Examples.....	15
1-7	Function Tables Arranged by Purpose .....	19
1-7-1	Sync Cycles and Synchronized data.....	19
1-7-2	Position and Speed Control .....	21
1-7-3	Measuring Input Pulses.....	25
1-7-4	High-speed Analog I/O Control .....	26
1-7-5	Controlling Timing .....	28

# 1-1 Outline of FQM1 Flexible Motion Controller

The FQM1 (Flexible Quick Motion) is a stand-alone Flexible Motion Controller that can be used to create flexible high-speed, high-precision motion control systems for 2 to 8 axes.

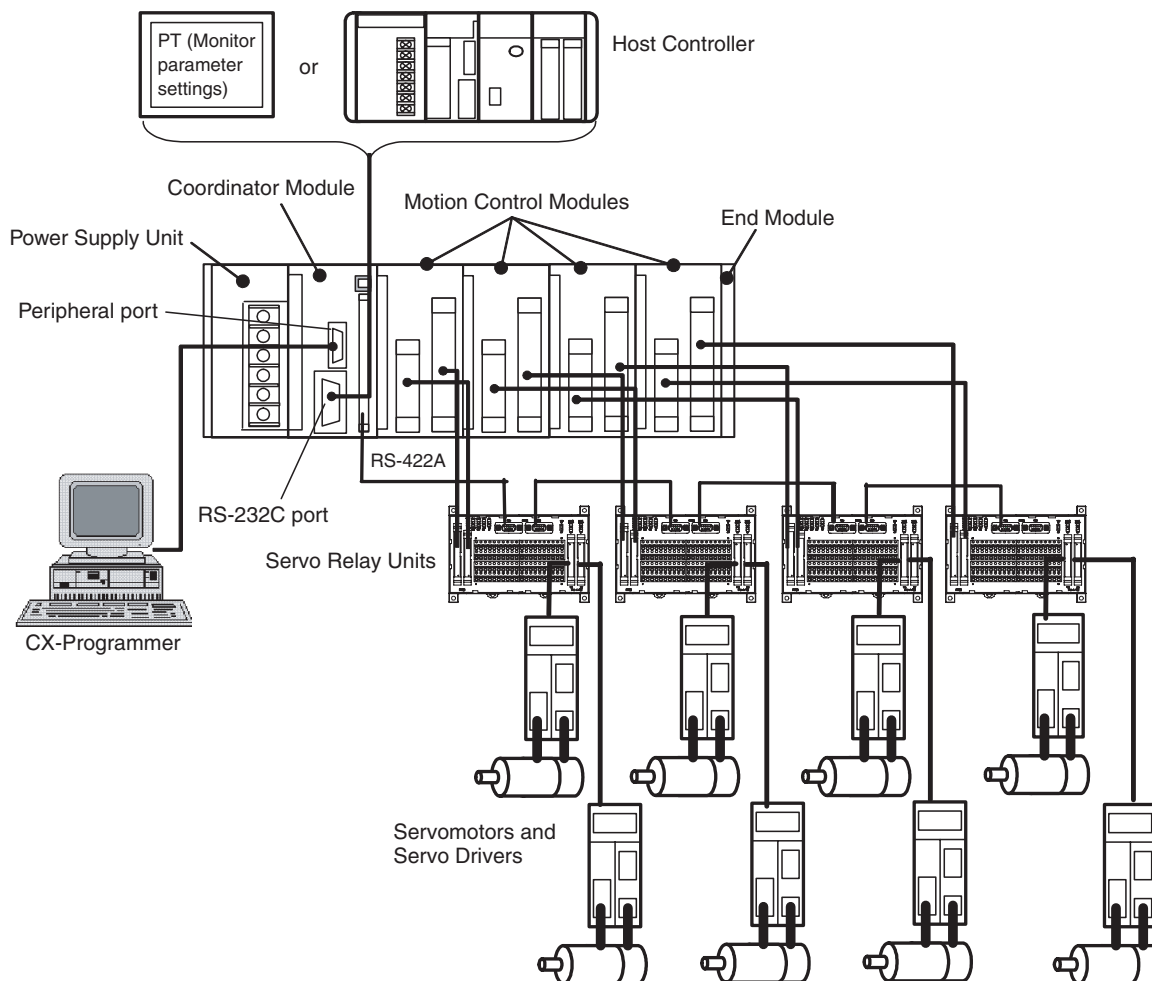

### Flexible Configurations of Up To 8 Axes

An FQM1 Flexible Motion Controller System is made up of a Power Supply Unit, a Coordinator Module, one or more Motion Control Modules, and an End Module.

Motion Control Modules are available with either pulse I/O or analog I/O, and a mixture of up to four Motion Control Modules can be included in one system (up to three if only analog I/O Motion Control Modules are used.) A flexible system ideal for the application can be created because each Motion Control Module controls two axes, giving total motion control of eight axes when four Motion Control Modules are connected.

### High-speed Processing

Each Motion Control Module and Coordinator Module has independent ladder programming, allowing high-speed independent control of pulse and analog I/O. Data can be shared between all Modules. The Coordinator Module performs general-purpose I/O control and manages overall system operation.

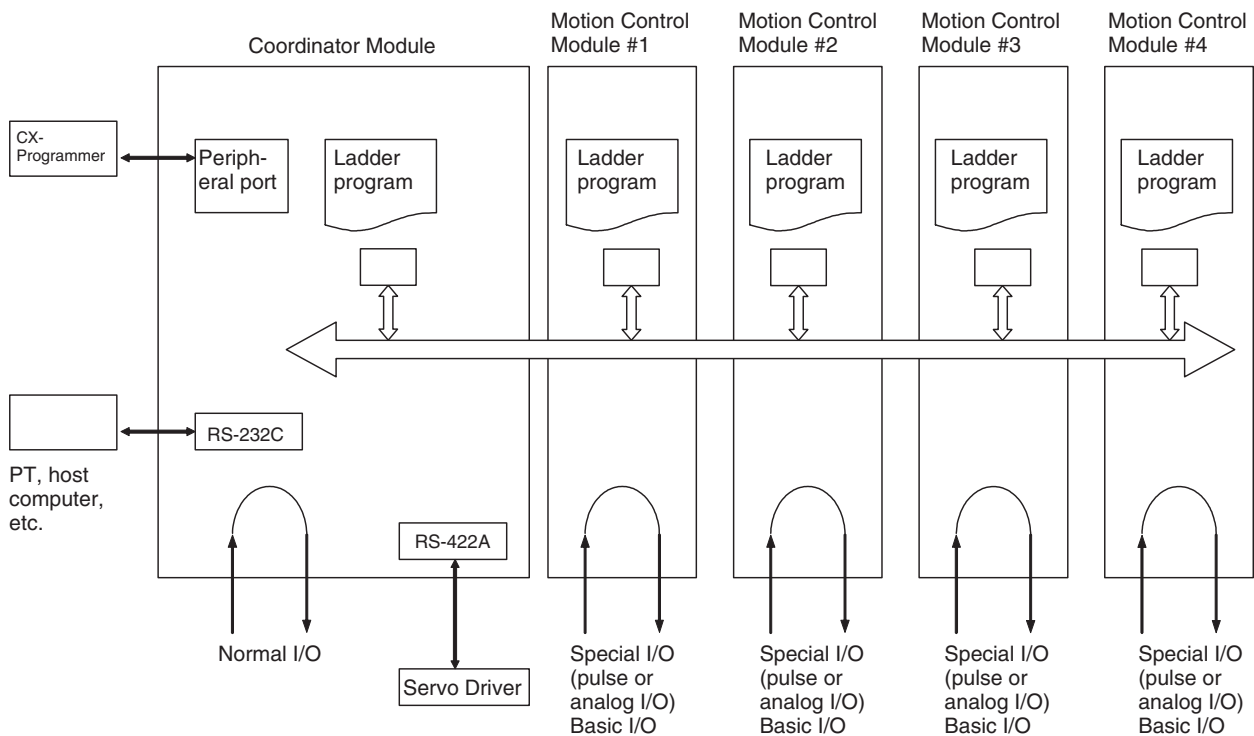

**Built-in RS-232C Port in Coordinator Module**

A Programmable Terminal (PT) can be connected to the Coordinator Module to monitor present values on the PT or make parameter settings for Servomotors from the PT.

The RS-232C port is useful for a variety of applications. It can be used, for example, to connect to a host computer or for a Serial PLC Link connection to a SYSMAC CJ1M Programmable Controller.

**Built-in RS-422A Port in Coordinator Module**

A PT can be connected to the Coordinator Module so that Servo parameters can be read from and written to Servomotors/Servo Drivers using a Serial Gateway Function.

Commands can also be sent from the Coordinator Module ladder program to Servomotors/Servo Drivers.

**Motion Control with Familiar Ladder Programming**

The Coordinator Module and Motion Control Modules each have their own ladder program, which perform basic I/O and special I/O (pulse I/O and analog I/O).

**Built-in General-purpose I/O in Coordinator Module**

The Coordinator Module has 24 built-in I/O (16 inputs and 8 outputs) for communications with host controllers and 12 inputs and 8 outputs for Motion Control Modules.

**Built-in General-purpose I/O in Motion Control Modules**

Motion Control Modules have 12 contact inputs and 8 contact outputs for I/O with peripheral devices.

**Connections for Absolute Servomotors**

Motion Control Modules can read absolute position data from W-series Absolute Servomotors/Servo Drivers.

**High-speed Counter Latch Function**

The high-speed counter latch function latches the high-speed counter's PV using 2 external signals. Ladder programs can then be used to read the latched values.

**Pulse Input Sampling Function**

The number of pulse inputs within a specified time can be measured.

**Pulse Input Frequency Measurement Function**

The speed of pulse inputs can be measured at the same time as the number of pulse inputs is counted.

**Wide Variety of Interrupt Functions**

The FQM1 can provide high-speed I/O responses because it has a wide variety of functions for starting interrupt tasks, in addition to input interrupts, interval timer interrupts, high-speed counter interrupts, and pulse output interrupts.

**High-speed Analog I/O Supported**

Motion Control Modules with analog I/O support linear (displacement/length measurement) sensor input, inverter control, and control of Servomotors with analog-input Servo Drivers. This gives flexibility for a great variety of motion applications.

**Writing and Monitoring Ladder Programs**

The ladder program for each Module is written using CX-Programmer Ver. 5.01 or later (see note) and then written to each Module via the peripheral port on the Coordinator Module. The ladder program is saved in each Module and operation of the program can be monitored from the CX-Programmer.

**Note** FQM1 Patch Software must be installed for CX-Programmer Ver. 5.0.

## 1-2 FQM1 Configuration

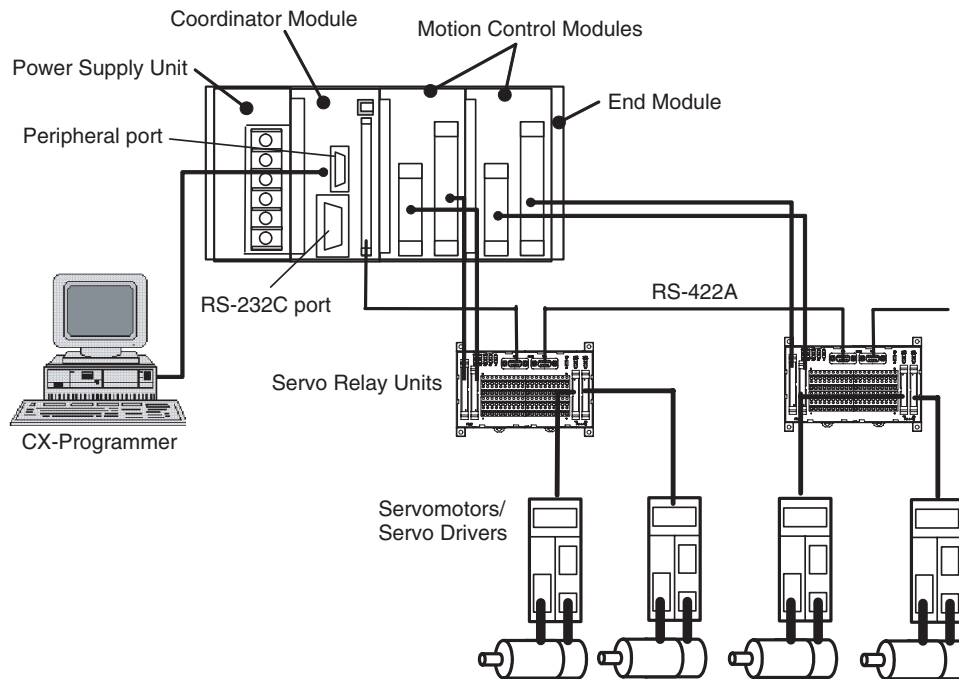

The FQM1 consists of a Power Supply Unit, a Coordinator Module, one or more Motion Control Modules, and an End Module. Motion Control Modules are available with either pulse I/O or analog I/O and up to four Motion Control Modules can be connected in one system. (See note.)

**Note** The number of Motion Control Modules with Analog I/O that can be connected is limited by the output capacity of the Power Supply Unit.

**FQM1-CM001 Coordinator Module**

One Coordinator Module is required in an FQM1. The Coordinator Module provides the following:

I/O: 16 inputs, 8 outputs  
 Program capacity: 5 Ksteps  
 DM Area capacity: 32 Kwords (DM)

- The CX-Programmer (Ver. 5.01 or later) is connected to the peripheral port on the Coordinator Module, and a PT (Programmable Terminal) or other device is connected to the RS-232C port.
- The Coordinator Module has its own ladder program, which is used to coordinate Motion Control Module data.
- The Coordinator Module has 24 general-purpose I/O (16 inputs and 8 outputs).
- The Coordinator Module has a Cyclic Refresh Bit Area, in which 10 words are allocated for cyclic refreshing with each Motion Control Module. This area is refreshed each Coordinator Module cycle.
- The Coordinator Module has a Synchronous Data Link Bit Area, in which 4 words are allocated for sharing with the Synchronous Data Link Bit Area of each Motion Control Module.

**FQM1-MMP21/MMA21 Motion Control Modules**

Each Motion Control Module provides the following:

Pulse I/O Motion Control Module	FQM1-MMP21	Program capacity: 5 Ksteps Pulse inputs: 2 Pulse outputs: 2 General-purpose inputs: 12 General-purpose outputs: 8
Analog I/O Motion Control Module	FQM1-MMA21	Program capacity: 5 Ksteps Pulse inputs: 2 Analog inputs: 1 Analog outputs: 2 General-purpose inputs: 12 General-purpose outputs: 8

- Rotary Encoders, Linear Sensors, Servos, Inverters, etc., can be connected to the special I/O.
- Each Motion Control Module has a ladder program for executing motion control and other functions.
- Each Motion Control Module has 20 general-purpose I/O (12 inputs and 8 outputs).
- Each Motion Control Module has 10 words allocated in the Coordinator Module's Cyclic Refresh Bit Area that is refreshed every Coordinator Module cycle.
- Each Module cycle, 4 words of Motion Control Module Synchronous Data Link Bit Area data is shared with the Coordinator Module's Synchronous Data Link Bit Area.

**CJ1W-PA202/PA205R Power Supply Units**

SYSMAC CJ-series Power Supply Units are used.

CJ1W-PA202	100 to 240 V AC, output capacity: 5 V DC, 2.8 A, 24 V DC, 0.4 A, up to 14 W total.
CJ1W-PA205R	100 to 240 V AC, output capacity: 5 V DC, 5.0 A, 24 V DC, 0.8 A, up to 25 W total.

Select a Power Supply Unit with a capacity greater than the total current consumption of the connected Modules.

**FQM1-TER01 End Module** One End Module is supplied with the Coordinator Module. Always attach the End Module because it acts as a terminator for the system. A fatal error will occur if no End Module is attached.

**Other Peripheral Devices** Special Servo Relay Units are available for connecting the FQM1 Flexible Motion Control system to OMRON W-series and SMARTSTEP Servo Drivers. Specific cables suitable for the connected Servomotor/Servo Driver models and the FQM1 Motion Control Module models are also available.

### 1-3 Modules

The Coordinator Module acts as the interface between the FQM1 system and peripheral devices, shares data with each Motion Control Module, and synchronizes specific data (e.g., virtual axis data) between Modules.

Item		Details	
Functions	Interfaces for peripheral devices	Connection with the CX-Programmer (peripheral port) Connection with PT for monitoring and parameter settings (RS-232C port) Connections with Servo Drivers (RS-422A port)	
	Sharing data with each Motion Control Module (each Coordinator Module cycle)	The 10 words are allocated for each Motion Control Module in the Cyclic Refresh Bit Area of the Coordinator Module (CIO 0100 to CIO 0139), based on the Motion Control Module slot number. These words correspond to CIO 0100 to CIO 0109 in the Cyclic Refresh Bit Area of each Motion Control Module. <ul style="list-style-type: none"> <li>Coordinator Module to Motion Control Module: 5 words (General-purpose output)</li> <li>Motion Control Module to Coordinator Module: 5 words (General-purpose input: 4 words, program RUN, fatal errors, non-fatal errors)</li> </ul> This cyclic refresh data is refreshed every Coordinator Module cycle.	
	Synchronized sharing of special data between Modules (broadcast at specified sync cycle)	User-specified synchronous data (see following list) can be allocated to CIO 0200 to CIO 0219 in the Synchronous Data Link Bit Area of the Coordinator Module and each Motion Control Module, 4 words at a time (2 types of data × 2 words). The allocations are fixed, starting with the Coordinator Module and followed by Motion Control Modules in order of slot number. <ul style="list-style-type: none"> <li>Any ladder program data</li> <li>High-speed counter PV</li> <li>Pulse output PV</li> <li>Analog input PV</li> <li>Analog output PV</li> <li>Built-in I/O input values</li> </ul> The synchronous data is broadcast each specified sync cycle and all other Modules receive this data in essentially real-time.	
	DM data transfer with specific Motion Control Modules (as required)	DM data (499 words max.) can be transferred in the specified direction between the specified words in the DM Area in the specified Motion Control Module and the specified DM Area words in the Coordinator Module when the DM Write Request Bit (A530.00) or DM Read Request Bit (A530.01) in the Auxiliary Area of the Coordinator Module turns ON.	
I/O	Serial communications	<ul style="list-style-type: none"> <li>Peripheral port: Peripheral bus (for CX-Programmer)</li> <li>One RS-232C port: NT Link (for OMRON PTs), Host Link (for host computers), or no protocol (for PLCs)</li> <li>One RS-422A port (Same connector as general-purpose I/O): 1:N communications with Servo Drivers (for transferring parameters to Servo Drivers)</li> </ul>	
	General-purpose I/O	General-purpose inputs: 16 General-purpose outputs: 8	40-pin connector (including RS-422A)
Programs	Program capacity	5 Ksteps (for data exchange with host computer, coordination of Motion Control Modules, and other peripheral programming)	



Outline of Internal Data Exchange and I/O

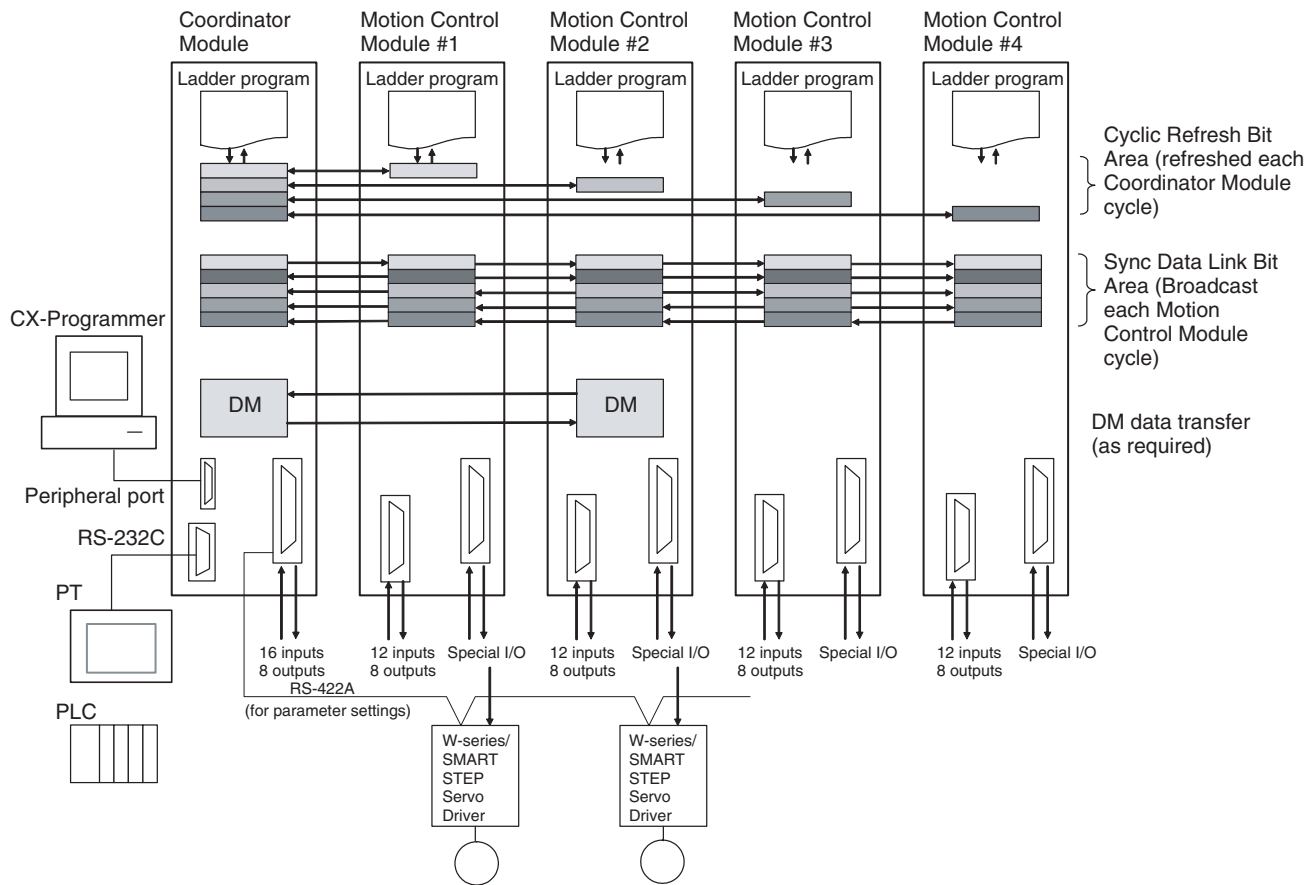

<p>Coordinator Module</p>	<ul style="list-style-type: none"> <li>• Peripheral port for connecting CX-Programmer and RS-232C port for connecting PTs and other devices</li> <li>• Ladder program for coordinating Motion Control Module data and other functions</li> <li>• 24 general-purpose I/O</li> <li>• 10 words of cyclic refresh data for each Motion Control Module allocated in Cyclic Refresh Bit Area, which is refreshed each Coordinator Module cycle</li> <li>• 4 synchronous data link words allocated for each Motion Control Module in Coordinator Module's Synchronous Data Link Bit Area, which is shared each Module cycle</li> </ul>
<p>Motion Control Modules</p>	<ul style="list-style-type: none"> <li>• Linear Sensors, Servo Drivers, Inverters, etc., connected to special I/O</li> <li>• Ladder program for executing motion control and other functions</li> <li>• 20 general-purpose I/O</li> <li>• 10 words of cyclic refresh data for each Motion Control Module allocated in its Cyclic Refresh Bit Area, which is refreshed each Coordinator Module cycle</li> <li>• 4 synchronous data link words allocated for each Motion Control Module in Coordinator Module's Synchronous Data Link Bit Area, which is shared each Module cycle</li> </ul>

# 1-4 CX-Programmer

The CX-Programmer provides software functions for programming and debugging.

FQM1 Patch Software must be installed for the CX-Programmer Ver. 5.0 (Model: WS02-CXPC1-E-V50) to use it to create ladder programs, make settings in the System Setup, and monitor operation. The FQM1 Patch Software can be installed for CX-Programmer Ver. 5.0 or later, but not to Ver. 4.0 or earlier versions. Refer to 8-1 CX-Programmer.

## CX-Programmer

Item	Details		
Applicable Motion Controllers	FQM1 Series <b>Note</b> CX-Programmer can also be used for SYSMAC CS/CJ-series PLCs.		
OS	Microsoft Windows 95, 98, or NT4.0 Service Pack 6	Microsoft Windows 2000 or Me	Microsoft Windows XP
Personal computers	IBM PC/AT or compatible	IBM PC/AT or compatible	IBM PC/AT or compatible
Connection method	Peripheral port or built-in RS-232C port on the Coordinator Module		
Communications protocol with FQM1	Peripheral Bus or Host Link		
Offline functions	Programming, editing of I/O memory, System Setup, printing		
Online functions	Transferring comparing data, monitoring, System Setup		
Main functions	<ol style="list-style-type: none"> <li>1. Programming functions: Creating and editing of applicable FQM1 ladder or mnemonic programs.</li> <li>2. Changing operating modes for each Module.</li> <li>3. Transfer functions: Transferring programs, I/O memory data, and System Setup between computer and Modules.</li> <li>4. Monitoring program execution status: Monitoring I/O bit status and PV using ladder display, monitoring I/O bit status and PV using mnemonic display, and monitoring PV using I/O memory display.</li> </ol>		

**Note** The CX-Programmer can be connected online to FQM1 Coordinator Modules and Motion Control Modules at the same time. If the default baud rate is changed when Coordinator and Motion Control Modules are connected at the same time, set the baud rate to 38.4 kpps max.

# 1-5 Expanded System Configuration

## 1-5-1 Serial Communications

The FQM1 system can be expanded using the two serial ports built into the Coordinator Module: Peripheral port and RS-232C port.

### System Configuration

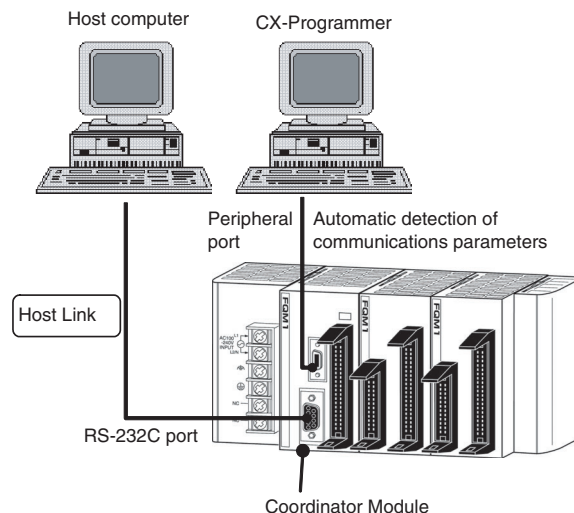

## 1-5-2 Systems

The serial communications port mode (protocol) can be switched in the Coordinator Module's System Setup. Depending on the protocol selected, the following systems can be configured.

### Protocols

The following protocols support serial communications.

Protocol	Main connection	Use	Applicable commands and communications instructions
Host Link (SYS-MAC WAY)	Personal computer OMRON Programmable Terminals (PTs)	Communications between the host computer and the Module	Host Link commands/ FINS commands
No-protocol (custom) communications	General-purpose external devices Servo Drivers Host controllers	No-protocol communications with general-purpose devices, host controllers, and Servo Drivers	TXD(236) instruction and RXD(235) instruction
NT Links (1: N)	OMRON Programmable Terminals (PTs)	High-speed communications with Programmable Terminals via direct access	None
Peripheral Bus (Toolbus)	CX-Programmer	Communications between the CX-Programmer running on a computer and the FQM1	None
Serial PLC Link Slave	OMRON PLC	Communications between OMRON PLC and the FQM1	None
Serial Gateway	OMRON Programmable Terminals (PTs) Servo Drivers	Communications between a PT and W-series or SMARTSTEP Servo Drivers via the FQM1	FINS commands

**Host Link System**

The Host Link System allows the I/O memory of the Modules to be read/written and the operating mode to be changed from a host computer (personal computer or Programmable Terminal (PT)) by executing Host Link commands or FINS commands that are preceded by a Host Link header and followed by a terminator. A Host Link System is possible for either the peripheral port or the RS-232C port on the Coordinator Module.

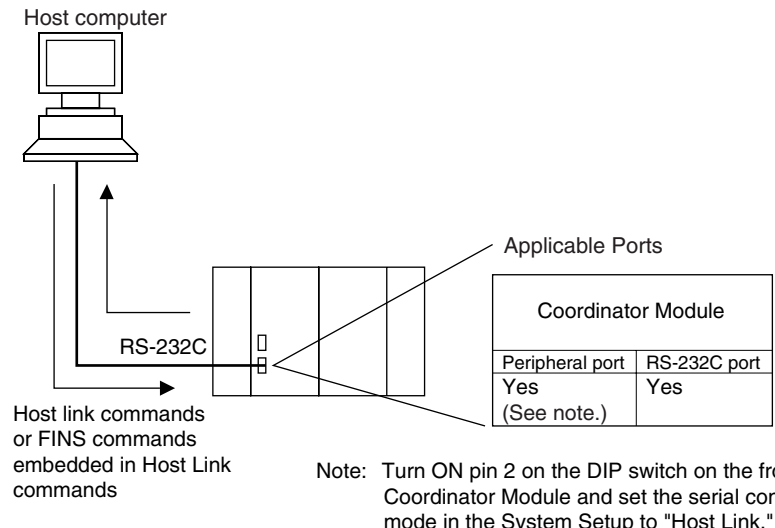

**No-protocol (Custom) Communications System via RS-232C Port**

No-protocol communications allow simple data transmissions, such as inputting bar code data and outputting printer data using communications port I/O instructions TXD(236) and RXD(235). The start and end codes can be set and, RS and CS signal control is also possible with no-protocol communications.

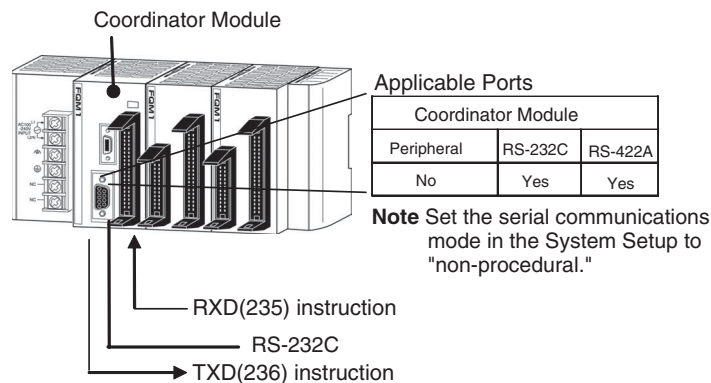

**NT Link System (1:N Mode, Standard)**

If the FQM1 and a Programmable Terminal (PT) are connected together using the RS-232C port, the allocations for the PT's status control area, status notify area, objects such as touch switches, indicators, and memory maps can be allocated in the I/O memory of the FQM1.

The NT Link System allows the PT to be controlled by the FQM1, and the PT can periodically read data from the status control area of the FQM1, and perform necessary operations if there are any changes in the area. The PT can communicate with the FQM1 by writing data to the status notify area of the FQM1 from the PT. The NT Link System allows the PT status to be controlled and monitored without using FQM1 ladder programming. The ratio of FQM1 Controllers to PTs is 1: n (n ≥ 1).

Set the PT communications settings for a 1:N or Standard NT Link. An NT Link System is possible for either the peripheral port or the RS-232C port.

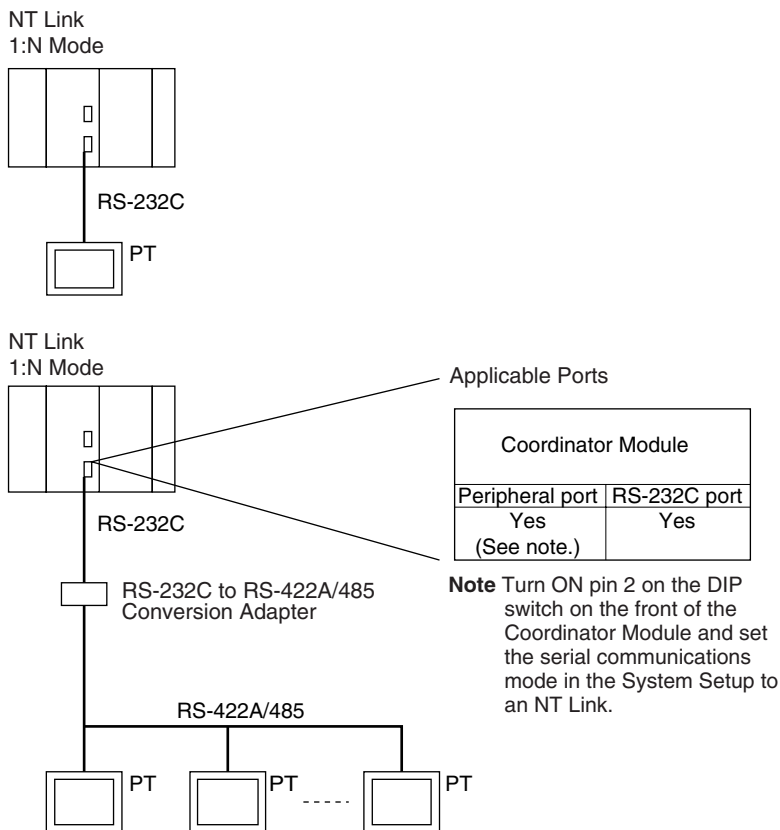

- Note**
- (1) The FQM1 can be connected to any PT port that supports 1:N NT Links. It cannot be connected to the RS-232C ports on the NT30 or NT30C, because these ports support only 1:1 NT Links.
  - (2) The Programming Console functionality of a PT (Expansion Function) cannot be used.
  - (3) When more than one PT is connected to the same FQM1, be sure that each PT is assigned a unique unit number. Malfunctions will occur if the same unit number is set on more than one PT.
  - (4) The NT Link System includes 1:1 and 1:N modes. These two modes are not compatible as serial communications modes.

**Serial PLC Link Slave**

The FQM1 can be connected to a Serial PLC Link by linking to a Serial PLC Master. (It cannot be connected by the Complete Link Method.) Program-free data exchange can be achieved between the master and slave by connecting a CJ1M CPU Unit as the master and the FQM1 as the slave. The FQM1 connection is made to the RS-232C port on the Coordinator Module.

CIO 0080 to CIO 0099 in the Serial PLC Link Bit Area in the Coordinator Module are shared with the CJ1M master as shown below

- Note** Use a CJ1W-CIF11 RS-232C to RS-422A/485 Conversion Adapter when connecting more than one FQM1 to the same CJ1M CPU Unit (1:N, where N = 8 max.).

**1:N Connection between CJ1M and FQM1 Controllers**

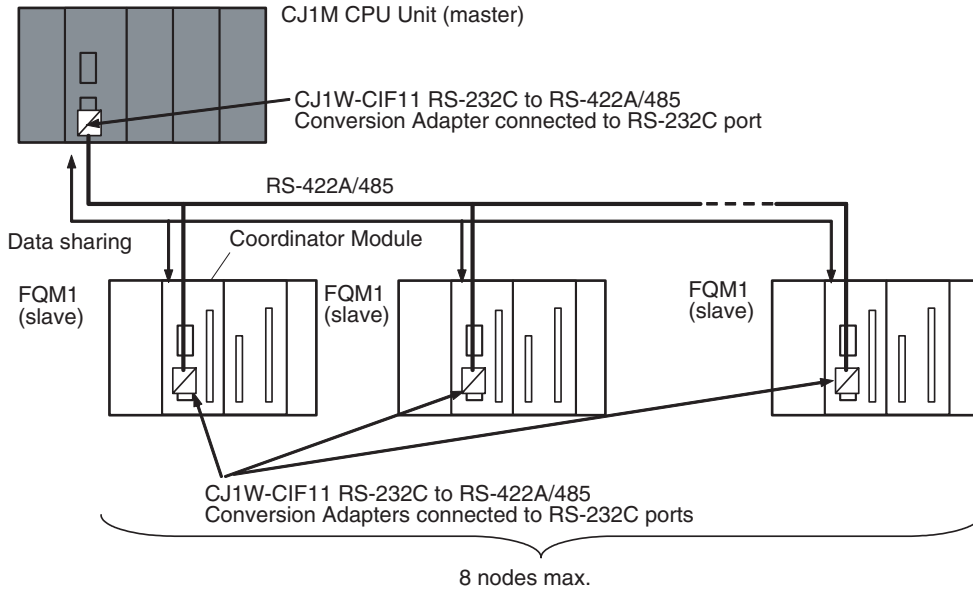

**1:1 Connection between CJ1M and FQM1 Controller**

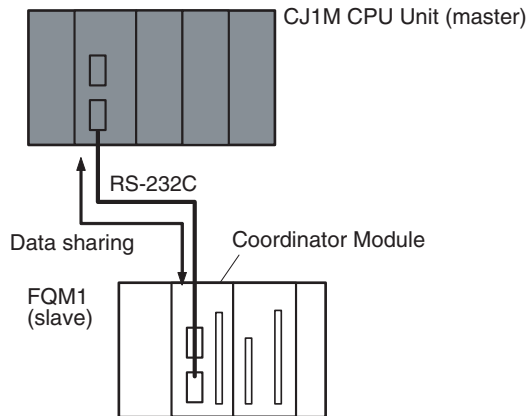

**Serial Gateway**

Reading/writing Servo Parameters and other data in Servo Drivers connected via RS-422A can be performed through the FQM1 Coordinator Module from an NS-series PT or computer application running on CX-Server. The serial communications mode for the RS-422A port on the FQM1 Coordinator Module is set to Serial Gateway to achieve this.

**Servo Drivers Connectable to RS-422A**

OMRON's W-series or SMARTSTEP Servo Drivers can be connected.

**System Configuration Example**

Smart Active Parts on an NS-series PT connected via an NT Link can be used to access W-series or SMARTSTEP Servo Drivers.

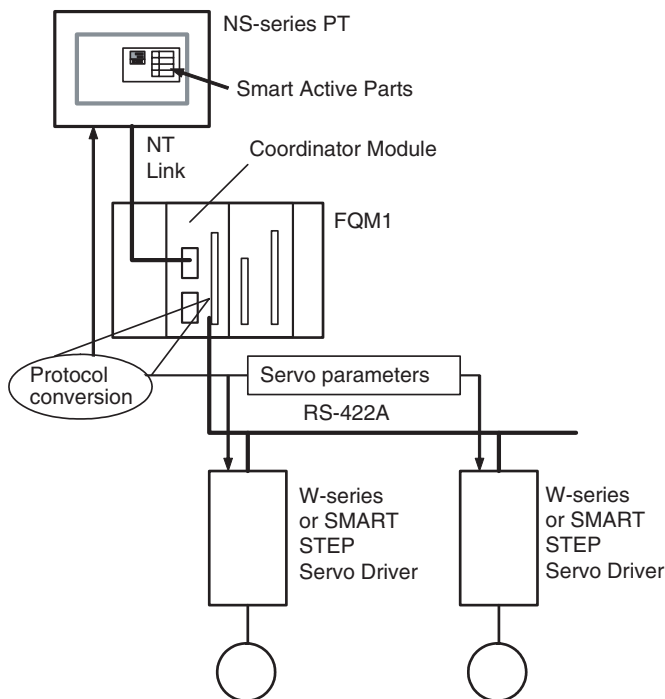

**No-protocol (Custom) Communications System via RS-422A Port**

No-protocol communications allow simple data transmissions, such as inputting bar code data and outputting printer data using communications port I/O instructions TXD(236) and RXD(235). The start and end codes can be set with no-protocol communications.

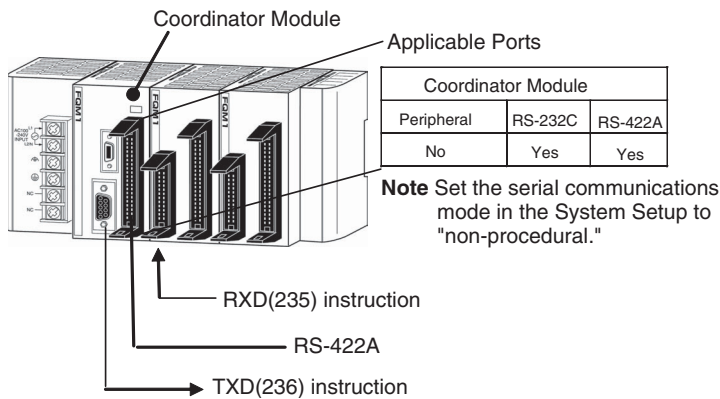

**1-6 Basic Operating Procedure**

The following procedure outlines the normal steps to operate the FQM1.

1,2,3...

1. Installation  
 Connect the Power Supply Unit, Coordinator Module, Motion Control Modules, and End Module. Refer to 3-1-4 *Connecting FQM1 Components* for details.  
 Mount the FQM1. Refer to 3-1-5 *DIN Track Installation* for details
2. Wiring  
 Connect the power supply wiring and ground. Refer to 3-2-1 *Wiring Power Supply Units* for details.

Wiring I/O terminals and connectors. Refer to 3-3 *Wiring Module Connectors* for details.

3. Initial Hardware Settings

Set the DIP switch on the front of the Coordinator Module as required. Refer to 2-3 *Coordinator Module* for details.

4. Turning ON Power and Checking Initial Operation

Connect the CX-Programmer (using CX-Programmer Ver. 5.0 with the FQM1 Patch Software installed). Refer to 3-1-4 *Connecting FQM1 Components* for details.

Check the power supply wiring and voltage and then turn ON the power supply. Check the RDY indicator and CX-Programmer display. Refer to 8-2 *Connecting the CX-Programmer* for details.

5. System Setup Settings Using the CX-Programmer

With the FQM1 in PROGRAM mode, change the settings in the System Setup as necessary from the CX-Programmer online. (Another method is to change the System Setup in CX-Programmer offline and transfer it to the Coordinator Module and Motion Control Modules.) Set the Sync Mode under *Synchronization between Modules* to ASync Mode to make debugging easier. Refer to *System Setup in the Coordinator Module* on page 309 in *Appendix C System Setup, Auxiliary Area Allocations, and Built-in I/O Allocations* for details.

6. Writing the Programs

Write the programs for the Coordinator Module and Motion Control Modules with the CX-Programmer. Refer to *Appendix A Programming* and to the *FQM1 Instructions Reference Manual* (Cat. No. O011) for details.

7. Transferring the Programs

Transfer the programs from CX-Programmer to the Coordinator Module and Motion Control Modules.

8. Testing Operation

a. Checking I/O Wiring

<b>Output wiring</b>	With the FQM1 in PROGRAM mode, force-set output bits and check the status of the corresponding outputs.
<b>Input wiring</b>	Activate sensors and switches and either check the status of the input indicators or check the status of the corresponding input bits with the CX-Programmer's Bit/Word Monitor operation.

b. Trial Operation

Test operation after switching the FQM1 to MONITOR mode.

c. Monitoring and Debugging

Monitor operation from the CX-Programmer. Use functions such as force-setting/force-resetting bits, tracing, and online editing to debug the program.

**Note** If the Coordinator and Motion Control Modules are connected at the same time, set the baud rate to 38.4 kpps max.

9. Saving and Printing the Programs

Save the debugged ladder programs and System Setup.

10. Running the Programs

Switch the FQM1 to RUN mode to run the programs.



### 1-6-1 Examples

#### 1. Installation

Connect the Power Supply Unit, Coordinator Module, Motion Control Modules, and End Module to assemble the FQM1.

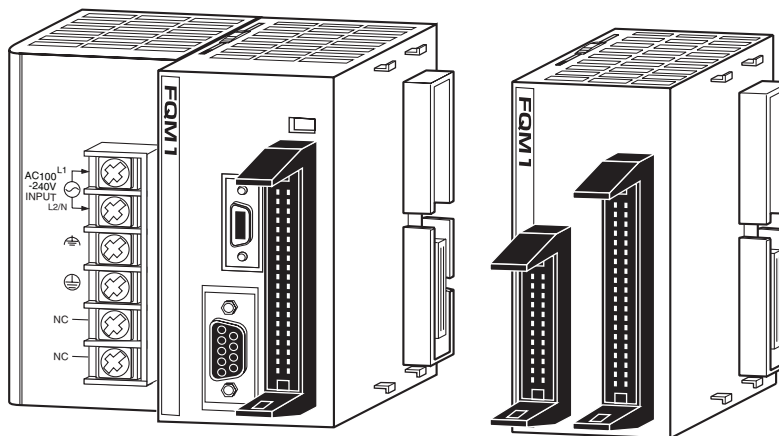

Make sure that the total power consumption of the Modules is less than the maximum capacity of the Power Supply Unit.

Use DIN Track to mount the FQM1 to the control panel.

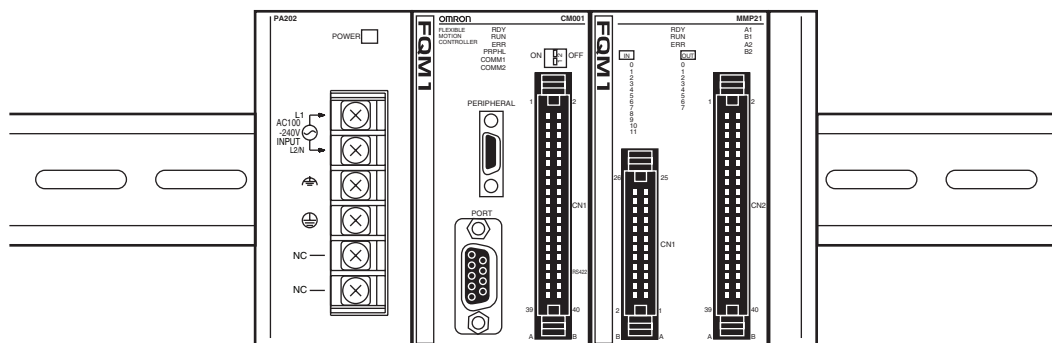

#### 2. Wiring

Connect the power supply, ground, and I/O wiring.

#### 3. Initial Hardware Settings

Set the DIP switch on the Coordinator Module. In particular, be sure that the settings for the peripheral port are correct.

Example: When connecting the CX-Programmer to the peripheral port, turn OFF pin 2.

**Note** When devices other than the CX-Programmer are connected to the peripheral port and RS-232C port, turn ON pin 2.

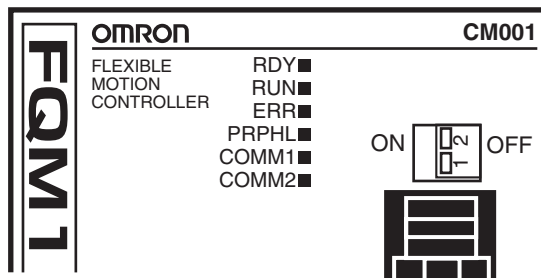

#### 4. Turning ON Power and Checking Initial Operation

**Note** The System Setup and user programs are backed up in built-in flash memory. When the data is being backed up, a message indicating the data is being transferred will be displayed on the CX-Programmer. Never turn OFF the power supply to the FQM1 while data is being backed up.

#### 5. System Setup Settings

These settings determine the Modules' software configuration. Refer to *Appendix C System Setup, Auxiliary Area Allocations, and Built-in I/O Allocations* for details.

**Note** The FQM1 is set to the Sync Mode by default. This mode must be changed on the Coordinator Module when programming Motion Control Modules, transferring programs, or debugging. Set the mode to ASync Mode in the System Setup of the Coordinator Module to enable changing the operating modes of the Motion Control Modules and creating programs directly from the CX-Programmer.

#### 6. Writing the Programs

Write each program with the CX-Programmer, including one cyclic task and the required number of interrupt tasks.

1,2,3...

1. Add Motion Control Modules to the tree by executing **Insert - PC** once for each Motion Control Module connected to the Coordinator Module.

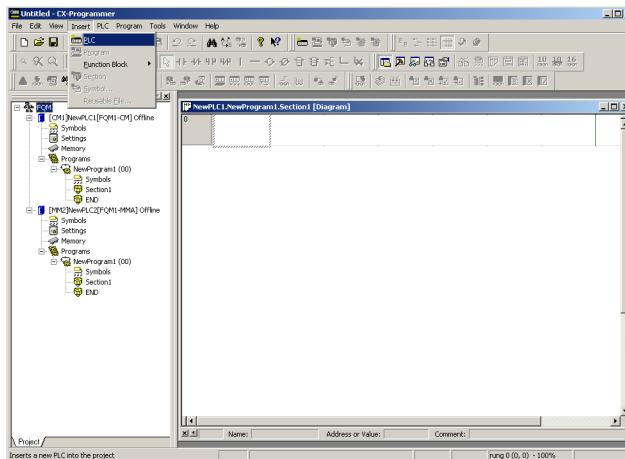

2. When going online to Motion Control Modules through the Coordinator Module, the node set for the FINS destination address in the network settings on the Change PC Type Window determines the Motion Control Module that is connected. Normally the node number is automatically allocated for the Motion Control Module when **Insert - PC** is executed.

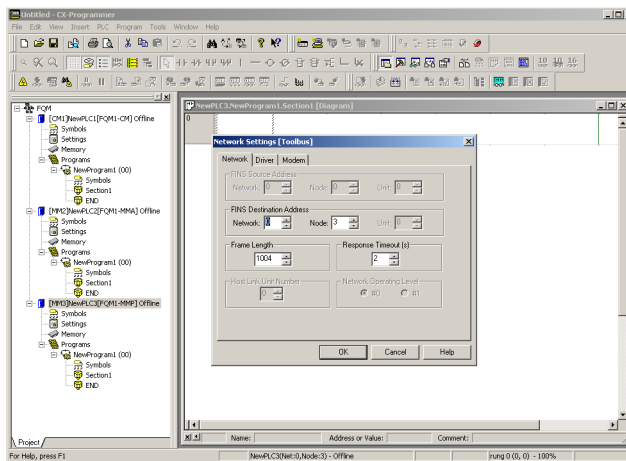

**7. Transferring the Programs**

When the programs has been created in the CX-Programmer, they must be transferred to the Motion Control Modules through the Coordinator Module.

**8. Testing Operation**

**8-a) I/O Wiring Checks**

**Check Output Wiring**

With the FQM1 in PROGRAM mode, force-set and force-reset output bits from the CX-Programmer and verify that the corresponding outputs operate properly.

**Check Input Wiring**

Activate input devices, such as sensors and switches, and verify that the corresponding input indicators light. Also, use the Bit/Word Monitor operation from the CX-Programmer to verify the operation of the corresponding input bits.

**8-b) Trial Operation**

Use the CX-Programmer to switch each Module to MONITOR mode.

**Using the CX-Programmer**

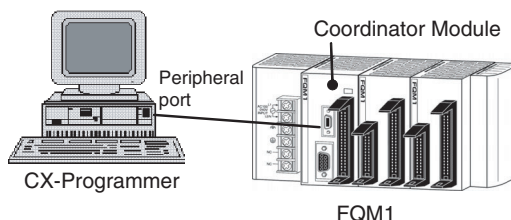

- Trial Operation
- Select **PC - Mode - MONITOR.**
- Actual operation
- Select **PC - Mode - RUN.**

**8-c) Monitoring and Debugging**

There are several ways to monitor and debug FQM1 operation, including the force-set and force-reset operations, differentiation monitoring, time chart monitoring, data tracing, and online editing.

**Force-Set and Force-Reset**

When necessary, the force-set and force-reset operations can be used to force the status of bits and check program execution.

From the CX-Programmer, select the bit to be force-set or force-reset and then select **Force On** or **Off** from the PLC menu.

**Differentiation Monitor**

The differentiation monitor operation can be used to monitor the up or down differentiation of particular bits. Use the following procedure from the CX-Programmer.

- 1,2,3...**
1. Select the bit for differential monitoring.
  2. Select **Differential Monitor** from the PLC Menu. The Differential Monitor Dialog Box will be displayed.
  3. Select **Rising** or **Falling**.
  4. Click the **Start** Button. The buzzer will sound when the specified change is detected and the count will be incremented.
  5. Click the **Stop** Button. Differential monitoring will stop.

#### **Time Chart Monitoring**

The CX-Programmer's time chart monitor operation can be used to check and debug program execution.

#### **Data Tracing**

The CX-Programmer's data trace operation can be used to check and debug program execution.

#### **Online Editing**

When a few lines of the program in a Module have to be modified, they can be edited online with the FQM1 in MONITOR mode or PROGRAM mode from the CX-Programmer. When more extensive modifications are needed, upload the program from the Module to the CX-Programmer, make the necessary changes, and transfer the edited program back to the Module.

### **9. Save and Print the Programs**

To save a program, select **File** and then **Save** (or **Save As**) from the CX-Programmer menus.

To print a program, select **File** and then **Print** from the CX-Programmer menus.

### **10. Run the Programs**

Switch the FQM1 to RUN mode to run the programs.

# 1-7 Function Tables Arranged by Purpose

## 1-7-1 Sync Cycles and Synchronized data

Purpose		Operation	Function used	Details
Synchronizing 3 or more axes	Simple control of all axes operations from the Coordinator Module	Synchronizing all Motion Control Modules to Coordinator Module cycle	Sync Mode, Sync Cycle Time	<p><i>5-1 Synchronous Operation between Modules</i></p> <p>Set Sync Mode to Sync and Sync Cycle Time to 0 ms. Executes Motion Control Module ladder programs at the same time as Coordinator Module ladder program, which makes it easy to control Motion Control Module program execution from the Coordinator Module ladder program.</p>
			Synchronous Data Link Bit Area	<p><i>5-2 Data Exchange between Modules</i></p> <p>If information to be shared between Modules every cycle is placed in the Synchronous Data Link Bit Area, it is automatically shared between Modules every cycle.</p> <p>Synchronous operation is also possible because programs can handle the same data between different Modules.</p> <p>Example: Sending position data for VIRTUAL AXIS (AXIS) instruction from a Module; sending high-speed counter PVs from pulse inputs, etc.</p>
			Constant Cycle Time (Coordinator Module) Sync Cycle Time (matches cycle time)	<p><i>5-1 Synchronous Operation between Modules</i></p> <p>The cycle time of the Coordinator Module can be made constant using the Constant Cycle Time function.</p> <p>This constant cycle time is set as the Sync Cycle Time in the FQM1.</p>
			Cycle Time (Motion Control Modules)	<p><i>5-1 Synchronous Operation between Modules</i></p> <p>The Coordinator Module's constant cycle time is set as the FQM1 Sync Cycle Time (as above). The I/O refresh interval for the Motion Control Module within that Sync Cycle Time is made constant, and the I/O cycle with external interfaces is also made constant.</p>
			Prohibit System Interruption of the Sync Mode	<p><i>5-4-4 Settings</i></p> <p>Used to synchronize, as much as possible, the start of processing between Modules.</p> <p>When system interrupts are prohibited, the variation in the start of processing between Modules is approx. 2 μs.</p>

Purpose		Operation	Function used	Details
Synchronizing 3 or more axes	Make control cycle as short as possible with Modules synchronized	Synchronizing Motion Control Modules only	Sync Mode, Sync Cycle Time	<p><i>5-1 Synchronous Operation between Modules</i></p> <p>Set Sync Mode to Sync and Sync Cycle Time to between 0.1 and 10.0 ms.</p> <p>If the Coordinator Module cycle varies or gets too long after connecting the FQM1 to peripheral devices, Motion Control Module operation can be synchronized to have short control cycles for Motion Control Modules only.</p> <p>The Sync Cycle Time can be set to any value.</p>
			Synchronous Data Link Bit Area	Same as "Synchronous Data Link Bit Area," above.
			Cycle Time (Motion Control Modules)	<p><i>5-1 Synchronous Operation between Modules</i></p> <p>The Coordinator Module's constant cycle time is set as the FQM1 Sync Cycle Time (as above). The I/O refresh interval for the Motion Control Module in that Sync Cycle Time is made constant and the I/O cycle with external interfaces is also made constant.</p>
			Prohibit System Interruption of the Sync Mode	Same as "Prohibit System Interruption of the Sync Mode" above.
	Control operation using pulse and analog data simultaneously	Synchronizing Motion Control Modules to Coordinator Module cycle or synchronizing between Motion Control Modules only	Synchronous Data Selection	<p><i>5-4 Synchronous Data Refresh</i></p> <p>Information for I/O from different Motion Control Modules can be stored within Modules and a control loop created.</p> <p>Select the type of synchronous data.</p> <ul style="list-style-type: none"> <li>• Ladder execution results</li> <li>• High-speed counter PV</li> <li>• Pulse output PV</li> <li>• Analog input values</li> <li>• Analog output values</li> <li>• Built-in I/O inputs</li> </ul>
Fast control loops		Changing to Async Mode	Sync Mode	<p><i>5-1 Synchronous Operation between Modules</i></p> <p>Set the Sync Mode to Async.</p> <p>Each Module will no longer be synchronized, bus refreshing will stop, and the Motion Control Module overhead time will be minimized.</p> <p>The minimum overhead time for FQM1-MMP21 is 0.19 ms.</p>

1-7-2 Position and Speed Control

Purpose		Operation	Main functions used	Details
PTP positioning using pulse I/O	Using Servo Driver compatible with an incremental encoder or stepping Servomotor/Servo Driver	Controlling positioning speed	<ul style="list-style-type: none"> <li>Relative pulse output functions</li> <li>Pulse output instructions (SPED(885)(885), ACC(888), PULS(886), and PLS2(887))</li> </ul>	<p><i>7-6-6 Pulse Output Function Details</i></p> <p>Set operating mode to Relative Pulse Output. The number of pulses is determined from the current position. Instructions to control pulses and speed can be used, depending on what is to be controlled. Speed can be controlled between 20 Hz and 1 MHz.</p> <ul style="list-style-type: none"> <li>Basic I/O can be used for origin signal and other I/O, and pulse inputs can be used for encoder inputs, for Servomotors/Servo Drivers</li> <li>For stepping motors, combination with basic I/O and pulse (CW) + direction control is possible.</li> </ul>
		Controlling trapezoidal positioning speed control	<ul style="list-style-type: none"> <li>PLS2(887) instruction</li> </ul>	<p><i>7-6-12 PLS2(887) Pulse Output Direction Priority Mode</i></p> <p>Trapezoidal positioning at any acceleration/deceleration ratio.</p> <p>The system will automatically switch to triangle control (trapezoidal control without constant speed interval) when acceleration/deceleration conditions with specified total output pulses do not lead to trapezoidal control.</p>
			Speed Change Cycle Selection (2 ms/1 ms)	<p><i>7-6-11 Acceleration/Deceleration Rates in ACC(888) and PLS2(887) Instructions</i></p> <p>The speed change cycle of ACC(888) and PLS2(887) instructions can be selected.</p> <p>This is useful for fine control of time taken to reach target speed or to reduce positioning time.</p>
		Defining the origin	Pulse Output PV Reset	<p><i>7-5-8 Pulse Input Function Description</i></p> <p>Turn ON the Pulse Output PV Reset Bit at the origin.</p> <p>A626.00 (pulse output 1)/A627.00 (pulse output 2) turn ON.</p>
Using Servo Drivers compatible with an Absolute Encoder		Controlling positioning speed	<ul style="list-style-type: none"> <li>Absolute Pulse Output</li> <li>Pulse output instructions (SPED(885)(885), ACC(888), PULS(886), and PLS2(887))</li> </ul>	<p><i>7-6-6 Pulse Output Function Details</i></p> <p>Change operating mode to Absolute Pulse Output.</p> <p>The number of pulses in the command is handled as an absolute position. Everything else is the same as relative pulse output.</p>
		Controlling trapezoidal positioning speed	<ul style="list-style-type: none"> <li>PLS2(887) instruction</li> <li>Pulse Output Direction/Absolute Position Priority Mode Setting</li> </ul>	<p>Same as for Servo Drivers compatible with an incremental encoder, outlined above.</p> <p><i>7-6-12 PLS2(887) Pulse Output Direction Priority Mode</i></p> <p>Can switch between giving priority to CW/CCW output direction specification for PLS2(887) instructions or absolute position specification to determine output direction.</p>

Purpose		Operation	Main functions used	Details
PTP positioning using pulse I/O	Using Servo Drivers compatible with an Absolute Encoder	Reading PV from Servo Driver	<ul style="list-style-type: none"> <li>• Absolute counter operation (absolute linear/circular)</li> <li>• High-speed counter absolute encoder read</li> </ul>	<p><i>7-7 Functions for Servo Drivers Compatible with Absolute Encoders</i></p> <p>Set counter operation to Absolute Linear (CW-), Absolute Circular, or Absolute Linear (CW+). Uses OMRON W-series Servo Drivers and reads the absolute position from the Servo Driver before operation starts.</p> <p>Once the origin has been set, it is easier to find the origin by reading the absolute position before operation starts.</p>
		Presetting the absolute position to the pulse output counter.	Pulse output counter PV convert (INI(880) instruction)	<p><i>7-6-6 Pulse Output Function Details</i></p> <p>Reflects in the pulse output instruction the absolute value read using the absolute encoder read instruction outlined above.</p>
PTP positioning using analog I/O	Using Servo Driver compatible with an incremental encoder	Position control in semi-closed loop using virtual pulse output function	<ul style="list-style-type: none"> <li>• Virtual axis (AXIS instruction)</li> <li>• High-speed counter (FB pulse)</li> <li>• Analog output instructions with position deviation using virtual axis and high-speed counter</li> </ul>	<p><i>7-8 Virtual Pulse Output Function</i></p> <p>Uses virtual axis (AXIS instruction) in relative mode.</p> <p>The current position output for the AXIS instruction is used as the command pulse to create a position loop with the high-speed counter PV (the feedback pulse from the Servo Driver). A control loop for the analog output instruction is generated according to this deviation and used.</p>
		Use Servo Drivers compatible with Absolute Encoder	Position control in semi-closed loop using virtual pulse output function	As above
		Reading current position from Servo Driver	<ul style="list-style-type: none"> <li>• Absolute counter mode (absolute linear/circular)</li> <li>• High-speed counter absolute encoder read</li> </ul>	Same as PTP positioning with pulse I/O when Servo Drivers compatible with Absolute Encoder used.
		Presets absolute position in AXIS instruction	<ul style="list-style-type: none"> <li>• High-speed counter PV</li> <li>• MOVL instruction</li> </ul>	<p><i>7-8 Virtual Pulse Output Function</i></p> <p>Presets the high-speed counter PV read using the high-speed counter absolute encoder read instruction outlined above, and presets and uses this PV as the current position output in the AXIS instruction.</p> <p>The PV is preset before executing AXIS instruction.</p>



Purpose		Operation	Main functions used	Details
PTP positioning using analog I/O	Simple positioning using inverters	Stepped or sloped analog output corresponding to the high-speed counter PV	<ul style="list-style-type: none"> <li>• Target value match instruction (CTBL(882) instruction) for high-speed counter</li> <li>• Analog output instruction (SPED(885) instruction) or analog output slope variation (ACC(888) instruction) in interrupt tasks</li> </ul>	<p><i>7-10 Analog Outputs</i></p> <p>Used when positioning only using speed command according to analog output.</p> <p>Applicable when speed patterns have been determined based on specified positions.</p> <p>An instruction to change the output variable every time instructions are executed (SPED(885) instruction) and an instruction to change analog outputs at a specified rate of change every 2 ms (ACC(888) instruction) are available for analog outputs.</p> <p>Fine speed control loops can be included using the FQM1 high-speed cycle time and analog output conversion functions (approx. 40 μs).</p>
Path control	Drawing path with linear interpolation	Executing electronic cam control for 2 axes synchronized to virtual axis	<ul style="list-style-type: none"> <li>• Virtual axis (AXIS instruction)</li> <li>• Create path tables using ladder program (APR instruction)</li> <li>• Electronic cam pulse output (PULS(886) instruction)</li> </ul>	<p><i>7-8 Virtual Pulse Output Function</i></p> <p>Pulse output operation mode set to electronic cam control mode (linear).</p> <p>Virtual axis used as basic axis. Path can be drawn by synchronizing 2 pulse output axes (controlled as slave axes) with the basic axis.</p> <p>Set the desired path pattern to the broken-line approximation instruction (APR instruction) table data, and execute pulse output control based on the APR instruction calculation result for the basic axis.</p> <p>The maximum number of line points for one APR instruction is 256, but multiple APR instructions can be used in ladder programs so the number of curve points can be increased by setting the table data across multiple APR instructions.</p>
	Drawing path with circular interpolation	As above	As above	
	Drawing elliptical and other special locus	As above	As above	
Synchronous control	Slave axis control synchronized to real axis.	Electronic cam: Changing target position and speed every cycle based on input pulse (position or angle for one rotation, etc.) to execute positioning.	<ul style="list-style-type: none"> <li>• High-speed counter PV</li> <li>• Cam curve generation or cam curve table every cycle based on ladder programming (APR instruction)</li> <li>• Pulse output with specified target position and frequency (PULS(886) instruction)</li> <li>• Constant cycle time</li> </ul>	<p><i>7-6-14 Pulse Output Function Examples</i></p> <p>Set pulse output operation mode to electronic cam control mode (linear) or electronic cam control mode (circular).</p> <p>Makes Motion Control Module cycle times constant, specifies target position and speed, and executes pulse outputs to Servo Driver for the slave axis according to high-speed counter PV.</p> <p>If cam curves are generated using ladder programming, the cam curves can be changed during operation.</p> <p>High-precision, synchronized control with external axes is possible with FQM1 high-speed cycle.</p>

Purpose		Operation	Main functions used	Details
Synchronous control	Slave axis control synchronized to virtual axis.	Electronic cam: Changing target position and speed every cycle based on virtual pulse output (position or speed) to execute positioning.	<ul style="list-style-type: none"> <li>• Virtual axis (AXIS instruction)</li> <li>• Cam curve generation or cam curve table every cycle based on ladder programming (APR instruction)</li> <li>• Pulse output with specified target position and frequency (PULS(886) instruction)</li> <li>• Constant cycle time</li> </ul>	<p><i>7-8 Virtual Pulse Output Function</i></p> <p>Execute pulse output control of slave axis based on virtual axis position and speed using AXIS instruction, instead of high-speed counter PV for real axis outlined above.</p> <p>Instead of the slave axis operation reflecting the real machinery operation outlined above, this method is used to operate position control for multiple axes using the same timing.</p>
	Control of a particular axis operation at a speed with a uniform ratio applied	Electronic gear operation: Pulse outputs based on input pulses multiplied by a set factor.	<ul style="list-style-type: none"> <li>• High-speed counter PV</li> <li>• Straight-line table (APR instruction)</li> <li>• Pulse outputs with specified target position and frequency (PULS(886) instruction)</li> <li>• Constant cycle time</li> </ul>	<p><i>7-6-13 Pulse Output Function Procedures</i></p> <p>Set pulse output operating mode to electronic cam control (circular).</p> <p>Prepare a straight line table whose slope becomes the multiplier for APR instruction and use APR instructions to calculate the pulse output target position for slave axis corresponding to high-speed counter PV and executes pulse output control.</p> <p>Speed is set and controlled to enable distribution of specified number of pulses within FQM1 control cycle.</p>
Speed control	Creating any trapezoidal speed control pattern (e.g., S-curve acceleration/deceleration) (fine control of acceleration/deceleration using time)	Electronic cam operation: Changing target position and speed every cycle according to time axis and perform positioning.	<ul style="list-style-type: none"> <li>• Cam curve generation or cam curve table every cycle based on ladder programming (APR instruction)</li> <li>• Pulse output with specified target position and frequency (PULS(886) instruction)</li> <li>• Constant cycle time</li> </ul>	<p><i>7-6-13 Pulse Output Function Procedures</i></p> <p>Set pulse output operation mode to electronic cam control mode (linear) or electronic cam control mode (circular).</p> <p>Used for applications such as creating ideal Servomotor control patterns.</p> <p>Makes the Motion Control Module cycle time constant, generates a time axis using ladder programming, specifies the target position and speed for the Servo Driver of the slave axis based on that time axis and gives pulse outputs.</p> <p>The time unit can be set to milliseconds, allowing fine control in FQM1 high-speed cycles.</p>

Purpose		Operation	Main functions used	Details
Speed control	Torque control (position + torque control) Individual axis control for molding equipment and similar applications	Switching between position and torque control modes.  During torque control, performing speed control using high-speed control loops based on feedback from torque sensors.	<ul style="list-style-type: none"> <li>• Analog input</li> <li>• Pulse input (for Servo Drivers compatible with Absolute Encoders)</li> <li>• Analog output</li> <li>• Feedback calculations using ladder programs</li> </ul>	<p>7-9 Analog Input Functions</p> <p>7-10 Analog Outputs</p> <p>Uses 2 analog outputs for speed and torque commands for Servo Driver.</p> <p>Can switch freely between position and torque control modes in ladder program, allowing for operations such as position control → torque control → position control.</p> <p>Speed and torque commands to Servo Drivers can be freely controlled during torque control based on feedback from torque sensors via analog inputs.</p> <p>Fine speed control is possible in FQM1 high-speed cycle.</p>
	Line control (winding/feeding control) Tension control, etc.	Performing analog output control based on feedback using analog inputs	<ul style="list-style-type: none"> <li>• Analog input</li> <li>• Analog output</li> <li>• Feedback calculations using ladder programs</li> </ul>	<p>7-9 Analog Input Functions</p> <p>7-10 Analog Outputs</p> <p>Performs speed control of winding and feeding motors while executing feedback calculations in ladder programs based on analog input information from dancer rollers or tension detectors.</p> <p>High-speed feedback loops can be created using FQM1 high-speed cycles and analog I/O conversion (approx. 40 μs).</p>
	Simple speed control corresponding to time axis using inverter	Controlling stepped or trapezoidal analog outputs based on time	<ul style="list-style-type: none"> <li>• Timer instructions</li> <li>• Analog output instructions (SPED(885) and ACC(888) instructions)</li> </ul>	<p>7-10 Analog Outputs</p> <p>Used to create any speed change pattern using an inverter.</p> <p>The speed pattern is based on the time axis, and the speed can be changed to any value once a set time has passed.</p>

### 1-7-3 Measuring Input Pulses

Purpose		Operation	Main functions used	Details
Detecting position and length using rotary encoder inputs	High-precision positioning	Counts high-speed encoder output using high-speed counter	Counting at 2 MHz (phase differential × 4)	<p>7-5-8 Pulse Input Function Description</p> <p>Set counter operation to phase differential × 4 and counting speed to 500 kHz.</p> <p>Can be used when high-speed pulse inputs need to be counted using high-speed counter for positioning in μm-units.</p>
	Reading high-speed counter PV when mark has gone past mark sensor	Latching high-speed counter PV when sensor turns ON for latch input	High-speed counter PV latch	<p>7-5-8 Pulse Input Function Description</p> <p>High-speed counter PV captured to latch register when external latch inputs change from OFF to ON.</p> <p>The values can be read using the PRV(881) instruction.</p> <p>Can be quickly read using hardware latch circuits.</p>

Purpose		Operation	Main functions used	Details
Detecting speed using rotary encoder inputs	Detecting speed and use in output control while managing position using encoder inputs	Measuring displacement of workpiece per unit time	Monitoring High-speed Counter Movement (cycle time)	<p><i>7-5-8 Pulse Input Function Description</i></p> <p>Outputs the change in the high-speed counter PV each cycle, while outputting number of input pulses as high-speed counter PV.</p> <p>Used for applications such as detecting speed of external master axis during synchronous control.</p>
			Monitoring High-speed Counter Movement (sampling time specified)	<p><i>7-5-8 Pulse Input Function Description</i></p> <p>Outputs the change in the high-speed counter PV each sampling cycle (1 to 9,999 ms) specified asynchronously to Motion Control Module cycle.</p> <p>Used for applications such as detecting external device speed or number of pulses within a specified time (not used for output control).</p>
	Monitoring speed while managing workpiece position using encoder input	Measure input pulse cycle	Counter frequency measurement (pulse input 1 only)	<p><i>7-5-8 Pulse Input Function Description</i></p> <p>Number of input pulses can be monitored simultaneously as high-speed counter PV and pulse frequency.</p>

### 1-7-4 High-speed Analog I/O Control

Purpose		Operation	Main functions used	Details
Measuring undulation, distortion, thickness, height, or diameter, etc., of an object	High-speed tracing of analog data when external signal turns ON	Storing analog input value in memory at specified time (constant cycle)	<ul style="list-style-type: none"> <li>Interval timer interrupts</li> <li>PRV(881) instruction</li> </ul>	<p><i>7-9-3 Analog Input Function Specifications</i></p> <p>Can perform analog sampling at a constant cycle, using scheduled interrupt processing in analog input immediate refresh mode.</p> <p>Sampling can be executed at small time intervals using analog input conversion (40 μs).</p> <p>Data stored in memory can also be displayed on PT and other display devices, e.g., to show trends.</p>
	High-speed tracing of analog data synchronized with target object position	Storing analog inputs to DM Area synchronous with position (pulse input)	High-speed analog sampling function	<p><i>7-9-7 High-speed Analog Sampling (FQM1-MMA21 Only)</i></p> <p>Sampling of target measurement object position as compared to the sampling based on time.</p> <p>Interrupt tasks, as outlined above, are not used, so even more detailed sampling is possible.</p> <p>Used for applications such as generating displacement data for the measurement object from one position to another position.</p>

Purpose		Operation	Main functions used	Details
Control using measurement results for undulation, distortion, thickness, height, diameter, etc., of an object	Judgment processing based on measurement results	Reading analog input values in high-speed cycles and performing judgment processing using ladder program	Analog input + ladder programming	<p><i>7-9 Analog Input Functions</i></p> <p>Uses analog sensors to detect objects that can't be detected with ON/OFF sensors and performs judgment by comparing the analog input value and internally held threshold values.</p> <p>Processing with faster tact time is possible using high-speed analog input conversion (40 μs) and high-speed cycle times (approximately 2 μs minimum when only analog inputs are enabled).</p> <p>Also, analog sampling at 50-μs intervals (min.) is possible if analog inputs are set to immediate refresh and PRV(881) instructions are used in parallel processing in the ladder program.</p>
	Position control using measurement results	Performing sync control using high-speed counter PV position information and analog input information simultaneously	Synchronous Data Link Bit Area	<p><i>7-6 Pulse Outputs</i></p> <p><i>7-9 Analog Input Functions</i></p> <p>Can perform synchronous control while performing position control on slave axis synchronized with position based on pulse input or synchronous control while adding analog value from displacement sensor as position control compensation.</p> <p>MMP21 and MMA21 used together for this application.</p>
Responding quickly to external signals with analog control	Changing analog output amount as soon as signal turns ON	Immediate refresh of analog output	<ul style="list-style-type: none"> <li>• Settings for immediate refresh</li> <li>• SPED(885)/ACC(888) instructions</li> </ul>	<p><i>7-10 Analog Outputs</i></p> <p>SPED(885) or ACC(888) instructions can be used to directly refresh analog outputs.</p> <p>Used to change output amount immediately after external signal triggers.</p>
	Reading analog input value as soon as signal turns ON	Immediate refresh of analog input	<ul style="list-style-type: none"> <li>• Settings for immediate refresh</li> <li>• PRV(881) instructions</li> </ul>	<p><i>7-9 Analog Input Functions</i></p> <p>PRV(881) instructions can be used to directly refresh analog inputs.</p> <p>Used to read input values immediately after external signal triggers.</p>
Holding analog output at the maximum value or at the value at that time when set conditions or errors occur.	---	Determining analog output value at output enable OFF or error	Analog output hold function	<p><i>7-10 Analog Outputs</i></p> <p>The analog output status can be held at the maximum value, cleared, or held at the current value at output enable OFF or system errors.</p>

## 1-7-5 Controlling Timing

Purpose		Operation	Main functions used	Details	
Responding quickly to external signals and operate	Executing processing as soon as change in external input signal detected	Starting interrupt processing when an input bit turns ON and/or OFF.	<ul style="list-style-type: none"> <li>Input function settings</li> <li>Interrupt inputs (MSKS(690) instructions)</li> </ul>	<i>7-3 Input Interrupts</i> <i>- Input Interrupt Mode</i> Set input function to Interrupt inputs. Executes interrupt tasks when Motion Control Module built-in input bits (input No. 0.00 to 0.03) turn ON and/or OFF.	
	Executing processing after set amount of external signal changes counted	Starting interrupt processing once the specified number of input bit rising edges, falling edges, or both have been counted	<ul style="list-style-type: none"> <li>Input function settings</li> <li>Counting interrupts in counter mode (MSKS(690) instruction)</li> </ul>	<i>7-3 Input Interrupts</i> <i>- Counter Mode</i> Set input function to Interrupt input and counter mode using MSKS(690) instructions. Decrements the PV each time the Motion Control Module built-in input bit (input numbers 0000.00 to 0000.03) turns ON and/or OFF and executes interrupt tasks when the PV reaches 0.	
	Repeating processes each time specified period passes	Starting interrupt processing at scheduled time	<ul style="list-style-type: none"> <li>Interval timer interrupt (scheduled interrupt: STIM(980) instruction)</li> </ul>	<i>7-4 Interval Timer Interrupts</i> <i>- 7-4-3 Interval Timer Interrupt Modes</i> Repeats interrupt task execution at scheduled intervals. Can be used within interrupt tasks because special timer used.	
	Executing processing once specified timer after startup signal input	Starting interrupt processing once only, after specified interval has elapsed	Starting interrupt processing once only, after specified interval has elapsed	<ul style="list-style-type: none"> <li>Interval timer interrupt (one-shot interrupt: STIM(980) instruction)</li> </ul>	<i>7-4 Interval Timer Interrupts</i> <i>- 7-4-3 Interval Timer Interrupt Modes</i> Executes interrupt task once only after specified period elapses. Can be used within interrupt tasks because special timer used.
			Starting interrupt processing once periods of any set time have elapsed from timer start	<ul style="list-style-type: none"> <li>Pulse output</li> <li>Target value comparison interrupt (CTBL(882) instruction)</li> </ul>	<i>7-6-9 Target-value Comparison Interrupts from Pulse Output PVs</i> Executes specified interrupt task when target value in registered table matches the pulse output counter PV.
	Starting processing when high-speed counter PV reaches set value	Starting interrupt processing when high-speed counter PV reaches specified value	<ul style="list-style-type: none"> <li>High-speed counter target value comparison interrupt (CTBL(882) instruction)</li> </ul>	<i>7-5 Pulse Inputs</i> Executes specified interrupt task when target value in registered table matches high-speed counter PV.	

Purpose		Operation	Main functions used	Details
Operation with highly precise timing	Increasing accuracy of external output ON time. (Feeding, hole opening, tape winding, gluing, and other applications)	High-precision ON outputs, with minimum unit of 0.01 ms	<ul style="list-style-type: none"> <li>One-shot pulse outputs (STIM(980) instruction)</li> </ul>	<p><i>7-5 Pulse Inputs</i></p> <p>Set pulse output operation mode to one-shot output.</p> <p>Specified outputs turn ON during specified interval (0.01 ms to 9,999 ms).</p> <p>Output OFF after specified time elapses is performed by hardware, which gives accurate ON time with no fluctuation.</p> <p>Can be used within interrupt tasks because uses special timer.</p>
	Highly accurate measurement of external input signal ON/OFF time	Starting/stopping high-precision timer at 0.001-ms unit min.	<ul style="list-style-type: none"> <li>Pulse output counter measurement mode (time measurement) (Unit: 0.001 ms min.)</li> </ul>	<p><i>7-6-8 Time Measurement with the Pulse Counter</i></p> <p>Time measurement starts/stops with input interrupt (MSKS(690) instruction) + STIM(980) instruction within interrupt tasks. The elapsed time is stored in Motion Control Module Auxiliary Area. This data can be read using the PRV instruction.</p> <p><b>Note</b> Pulse output 1 or pulse output 2 must be set to pulse counter time measurement in System Setup.</p>
	Various processing (instruction execution) at each one of multiple time intervals, using high-precision timer	Outputting ON/OFF pattern when pulse output counter PV is within set value range.	<ul style="list-style-type: none"> <li>Pulse output counter measurement mode (time measurement)</li> <li>Range comparison bit pattern output</li> </ul>	<p><i>7-6-8 Time Measurement with the Pulse Counter</i></p> <p>Can be used to obtain output pattern each time interval elapsed after timer start.</p> <p>Timer accuracy can be selected from as low as 0.001 ms.</p>
Timing output according to workpiece position	Timing output using high-speed counter PV	Outputting ON/OFF pattern when high-speed counter PV within certain range	<ul style="list-style-type: none"> <li>High-speed counter range comparison bit pattern output (Executes comparison at execution of CTBL(882) instructions)</li> </ul>	<p><i>7-5-8 Pulse Input Function Description</i></p> <p>Outputs set bit pattern when high-speed counter PV enters the range between set upper and lower limits.</p>





# SECTION 2

## Specifications and Nomenclature

This section provides the specifications of the FQM1 and describes the parts and their functions on the Coordinator Module and Motion Control Modules.

2-1	List of Models . . . . .	32
2-2	General Specifications . . . . .	32
2-3	Coordinator Module . . . . .	34
2-4	Motion Control Modules . . . . .	37
2-5	Dimensions . . . . .	43
2-6	Module Current Consumption . . . . .	45
2-7	Memory Block Diagram . . . . .	47

## 2-1 List of Models

Name	Type	Model	Specifications
Coordinator Module	Standard (with built-in I/O)	FQM1-CM001	Program capacity: 5 Ksteps 16 general-purpose inputs, 8 general-purpose outputs Peripheral port, RS-232C port, RS-422A port
Motion Control Modules	Pulse I/O	FQM1-MMP21	Program capacity: 5 Ksteps 2 pulse inputs, 2 pulse outputs, 12 general-purpose inputs, 8 general-purpose outputs
	Analog I/O	FQM1-MMA21	Program capacity: 5 Ksteps 2 pulse inputs, 1 analog input, 2 analog outputs, 12 general-purpose inputs, 8 general-purpose outputs
End Module	Standard	FQM1-TER01	Connects to the right end of the FQM1.
Servo Relay Units	---	XW2B-80J7-1A	Simplifies wiring from the Motion Control Module to two Servo Drivers, wiring for all switches, sensors, and other general-purpose I/O, and wiring the RS-422A line.
FQM1 Flexible Motion Controller Set	Set for pulse I/O	FQM1S-MC231	A set including the CJ1W-PA202, FQM1-CM001, FQM1-MMP21, and FQM1-TER01
	Set for analog I/O	FQM1S-MC222	A set including the CJ1W-PA205R, FQM1-CM001, FQM1-MMA21, and FQM1-TER01
Programming Device	CX-Programmer Ver. 5.0 or later	WS02-CXPC1-E-V5□ (See note.)	Used for System Setup setting, programming, and monitoring for Coordinator Modules and Motion Control Modules. The FQM1 patch file is used with CX-Programmer Ver. 5.0.

**Note** If CX-Programmer Ver. 5.0 is used with the FQM1, the FQM1 Patch Software must be installed.

## 2-2 General Specifications

### General Specifications

Item	Specifications
Insulation resistance	20 M $\Omega$ min. (at 500 VDC) between AC external and GR terminals (See note 1.)
Dielectric strength	2,300 V AC 50/60 Hz for 1 min between AC external and GR terminals (See notes 1 and 2.) Leakage current: 10 mA max.
	720 V AC 50/60 Hz for 1 min between DC external and GR terminals (See note 1.) Leakage current: 10 mA max.
Noise immunity	2 kV on power supply line (conforming to IEC61000-4-4)
Vibration resistance	10 to 57 Hz, 0.075-mm amplitude, 57 to 150 Hz, acceleration: 9.8 m/s <sup>2</sup> in X, Y, and Z directions for 80 minutes total (Time coefficient: 8 minutes $\times$ coefficient factor 10 = total time 80 min.) (conforming to JIS C0040)
Shock resistance	147 m/s <sup>2</sup> 3 times each in X, Y, and Z directions (conforming to JIS C0041)
Ambient operating temperature	0 to 55°C
Ambient operating humidity	10% to 90% (with no condensation)
Atmosphere	Must be free from corrosive gases
Ambient storage temperature	-20 to 75°C
Grounding	Less than 100 $\Omega$
Enclosure	Mounted in a panel.
Dimensions	49 $\times$ 90 $\times$ 80 mm (W $\times$ H $\times$ D) (not including cables)
Weight	All models are each 5 kg max.
Safety measures	Conforms to EC directives, C-Tick, and cULus.

- Note**
- (1) Disconnect the Power Supply Unit's LG terminal from the GR terminal when testing insulation and dielectric strength. Testing the insulation and dielectric strength with the LG and GR terminals connected will damage internal circuits.
  - (2) Do not apply more than 600 V when testing the dielectric strength of analog I/O terminals. Applying more than 600 V may damage the internal elements.

### Power Supply Unit Specifications

Item	Specifications	
Power Supply Unit	CJ1W-PA205R	CJ1W-PA202
Supply voltage	100 to 240 V AC (wide-range), 50/60 Hz	
Operating voltage and frequency ranges	85 to 264 V AC, 47 to 63 Hz	
Power consumption	100 VA max.	50 VA max.
Inrush current (See note 1.)	At 100 to 120 V AC: 15 A/8 ms max. for cold start at room temperature At 200 to 240 V AC: 30 A/8 ms max. for cold start at room temperature	At 100 to 120 V AC: 20 A/8 ms max. for cold start at room temperature At 200 to 240 V AC: 40 A/8 ms max. for cold start at room temperature
Output capacity	5.0 A, 5 VDC (including supply to Modules)	2.8 A, 5 VDC (including supply to Modules)
	0.8 A, 24 VDC	0.4 A, 24 VDC
	Total 25 W max.	Total 14 W max.
Output terminal	Not provided.	
RUN output	Contact configuration: SPST-NO Switching capacity: 250 V AC, 2 A (resistive load) 120 V AC, 0.5 A (inductive load) 24 VDC, 2 A (resistive load) 24 VDC, 2 A (inductive load)	Not provided.
Insulation resistance	20 MΩ min. (at 500 VDC) between AC external and GR terminals (See note 2.)	
Dielectric strength	2,300 V AC 50/60 Hz for 1 min between AC external and GR terminals (See note 2.) Leakage current: 10 mA max.	
	1,000 V AC 50/60 Hz for 1 min between DC external and GR terminals (See note 1.) Leakage current: 10 mA max.	
Noise immunity	2 kV on power supply line (conforming to IEC61000-4-4)	
Vibration resistance	10 to 57 Hz, 0.075-mm amplitude, 57 to 150 Hz, acceleration: 9.8 m/s <sup>2</sup> in X, Y, and Z directions for 80 minutes total (Time coefficient: 8 minutes × coefficient factor 10 = total time 80 min.) (conforming to JIS C0040)	
Shock resistance	147 m/s <sup>2</sup> 3 times each in X, Y, and Z directions (conforming to JIS C0041)	
Ambient operating temperature	0 to 55°C	
Ambient operating humidity	10% to 90% (with no condensation)	
Atmosphere	Must be free from corrosive gases.	
Ambient storage temperature	-20 to 75°C	
Grounding	Less than 100 Ω	
Enclosure	Mounted in a panel.	
Weight	5 kg. total max.	
Dimensions	80 × 90 × 65 mm (W × H × D)	45 × 90 × 65 mm (W × H × D)
Safety measures	Conforms to cULus and EC Directives.	

- Note**
- (1) The inrush current is given for a cold start at room temperature with an AC power supply. The AC inrush control circuit uses a thermistor element with a low-temperature current control characteristic. If the ambient temperature is high or the FQM1 is hot-started, the thermistor will not be sufficiently cool, and the inrush currents given in the table may be exceeded by up to twice the given values. When selecting fuses or breakers for external circuits, allow sufficient margin in shut-off performance. If the FQM1 is hot-started, the capacitor will not be discharged, and the inrush currents given in the table may be exceeded by up to twice the given values.
  - (2) Disconnect the Power Supply Unit's LG terminal from the GR terminal when testing insulation and dielectric strength. Testing the insulation and dielectric strength with the LG terminal and the GR terminals connected will damage internal circuits.

## 2-3 Coordinator Module

### Nomenclature

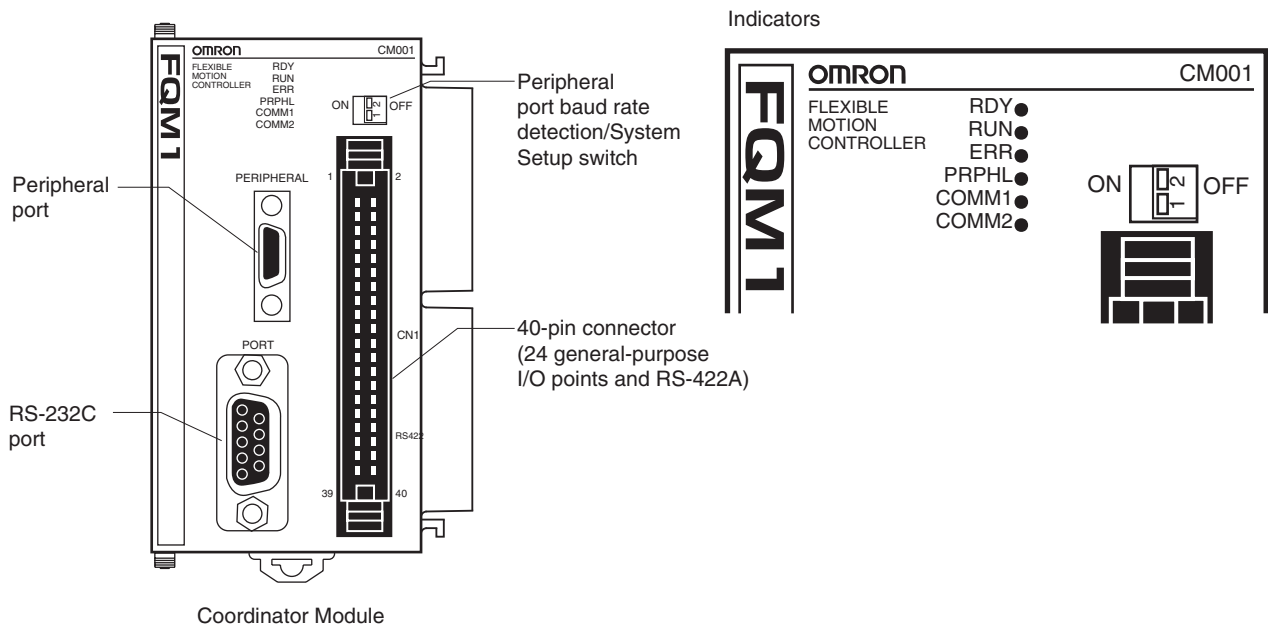

- Note** Cover the peripheral port and RS-232C port with the supplied covers when the ports are not being used to prevent dust contamination.

### Indicators

Indicator	Color	Name	Status	Meaning
RDY	Green	Module operation	Lit	The Module is operating normally.
			Not lit	Module error (e.g., WDT error).
RUN	Green	Program execution	Lit	Executing internal Module program.
			Not lit	Internal Module program stopped.
ERR	Red	Module error	Lit	Fatal error.
			Flashing	Non-fatal error.
			Not lit	Module operating normally.

Indicator	Color	Name	Status	Meaning
PRPHL	Yellow	Peripheral port communications	Lit	Communicating via the peripheral port.
			Not lit	All other times.
COMM1	Yellow	RS-232C communications	Lit	Communicating via the RS-232C port.
			Not lit	All other times.
COMM2	Yellow	RS-422A communications	Lit	Communicating via RS-422A port (for Servo Driver)
			Not lit	All other times

**Switch on Front Panel**

Peripheral Port Baud Rate Detection/System Setup Switch

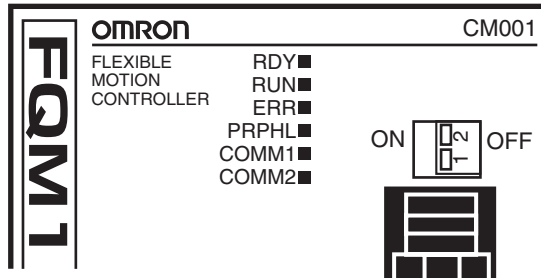

SW2	Peripheral port baud rate detection/System Setup	ON	System Setup settings
		OFF	Automatic baud rate detection
SW1	Reserved	---	

**Function Specifications**

Item		Specifications
Control method		Stored program
I/O control method		Cyclic scan
Programming		Ladder diagram
Instruction length		1 to 7 steps per instruction
Ladder instructions		Approx. 260
Execution time	Basic instructions	0.1 μs min.
	Special instructions	0.3 μs min.
Common processing (overhead) time		Sync Mode: 390 μs ASync Mode: 180 μs
Program capacity	Ladder	5 Ksteps
	Comment storage	None
Number of tasks		Cyclic tasks: 1, interrupt tasks: 50
Subroutines		256
JMP instructions		256
Number of basic I/O		24

Item		Specifications
CIO Area	Input Bit Area	16 bits (CIO 0000): CIO 0000.00 to CIO 0000.15
	Output Bit Area	8 bits (CIO 0001): CIO 0001.00 to CIO 0001.07
	Cyclic Refresh Bit Area	640 bits (40 words): CIO 0100 to CIO 0139 Refresh words for Motion Control Module # 1: CIO 0100 to CIO 0109 Refresh words for Motion Control Module # 2: CIO 0110 to CIO 0119 Refresh words for Motion Control Module # 3: CIO 0120 to CIO 0129 Refresh words for Motion Control Module # 4: CIO 0130 to CIO 0139
	Synchronous Data Link Bit Area	320 bits (20 words): CIO 0200 to CIO 0219 Sent from Coordinator Module: CIO 0200 to CIO 0203 Sent from Motion Control Module #1: CIO 0204 to CIO 0207 Sent from Motion Control Module #2: CIO 0208 to CIO 0211 Sent from Motion Control Module #3: CIO 0212 to CIO 0215 Sent from Motion Control Module #4: CIO 0216 to CIO 0219
	Serial PLC Link Bit Area	320 bits (20 words): CIO 0080 to CIO 0099 CIO 0080 to CIO 0089: CJ1M to FQM1 CIO 0090 to CIO 0099: FQM1 to CJ1M Can be connected as a Serial PLC Link slave to host PLC (CJ1M).
Work Bit Areas	CIO Area	2,784 bits: CIO 0002 to CIO 0079, CIO 0140 to CIO 0199, and CIO 0220 to 0255
	Work Area	4,096 bits: W000 to W255
Auxiliary Area	Read/Write	Read only: 5,568 bits: A000 to A099 and A200 to A447 Read/write: 3,232 bits: A448 to A649
	Error Log	100 words: A100 to A199 (20 records)
Temporary Area		16 bits: TR0 to TR15
Holding Area		None
Timer Area		256 timers: T0000 to T0255 (1-ms, 10-ms, and 100-ms timers)
Counter Area		256 counters: C0000 to C0255 (decrementing counters and reversible counters) <b>Note</b> Status not retained when power turned OFF.
DM Area	Read/Write (not retained)	30 Kwords: D00000 to D29999 (Status not retained when power is turned OFF.)
	Read/Write (retained)	2,768 words: D30000 to D32767 (Status retained in flash memory. Not retained if written by a ladder program, but retained in flash memory if written using the CX-Programmer.)
System Setup		System Setup area (Coordinator Module/Motion Control Module settings and peripheral service settings), peripheral service setting area
Index Registers		IR0 and IR1 used with JSB instruction.
Data Registers		None
Interrupt Functions	Input interrupts	None
	Timer interrupts	1 (Scheduled or one-shot interrupt)
Power interruption hold function (momentary power interruption)		Super capacitor
Memory backup	Super capacitor backup	Error log
	Flash memory	User programs, System Setup, part of DM Area
Trace memory		4,000 words
Peripheral servicing		Servicing for devices connected to peripheral port (only CX-Programmer), RS-232C port (Host Links, no-protocol communications, NT Links, and Serial PLC Links (slave)), and RS-422A port (for Servo Driver)
Self-diagnosis function		CPU errors (WDT) and memory errors
Program check		Programs checked from the CX-Programmer.
Super-capacitor backup time		Approximately 100 hours at 25°C
Clock		None
Fixed Power OFF detection time		AC: 10 to 25 ms (variable)
User-set Power OFF detection time		0 to 10 ms

Item		Specifications
RUN output		1 (when CJ1W-PA205R used)
Individual functions	Serial communications	Peripheral port: Peripheral bus (Toolbus), Host Links, NT Links Built-in RS-232C port on Coordinator Module: Peripheral bus (Toolbus), Host Links, no-protocol communications, NT Links, and Serial PLC Links (slave). Built-in RS-422A port on Coordinator Module: Servo Driver interface

**I/O Specifications**

**Built-in General-purpose I/O**

Item		Specifications
Inputs	Number of inputs	16
	Input voltage	20.4 to 26.4 V
	Input response	Inputs for normal input (16 points): ON delay time: 100 μs OFF delay time: 1 ms max. 8 points/common
Outputs	Number of outputs	8
	Output type	NPN transistor
	Switching capacity	4.5 to 30 V DC, 0.3 A per output
	ON delay time	0.1 ms max.
	OFF delay time	1 ms max.

**2-4 Motion Control Modules**

**Motion Control Module**

**FQM1-MMP21 (Pulse I/O)**

Item		Specifications	
I/O	Pulse I/O	Pulse inputs: 2 (compatible with Servo Drivers with absolute encoders) Pulse outputs: 2	40-pin connector
	General-purpose I/O	General-purpose inputs: 12 General-purpose outputs: 8	26-pin connector
Functions	Pulse outputs	The following operations are supported: <ul style="list-style-type: none"> <li>• Speed control (fixed, acceleration, deceleration)</li> <li>• Positioning (Fixed-speed positioning; trapezoid, acceleration/deceleration positioning, and deceleration positioning)</li> <li>• Speed control according to the present position (pulse output target value comparison or range comparison)</li> <li>• Electronic cam operation (Positioning according to the rotation position of the real or virtual axis.)</li> <li>• One-shot pulse output (Output ON only for specified time. minimum increment: 0.01 ms)</li> <li>• Time measurement using pulse counter (minimum increment: 0.0001 ms )</li> </ul>	
	Pulse inputs	<ul style="list-style-type: none"> <li>• High-speed counters: Phase, Increment/decrement, Pulse + direction inputs (50 kHz/1 MHz), or phase differential (50 kHz/500 kHz; phase differential × 4, 2 MHz )</li> <li>• High-speed counter can be started/stopped using counter start bit.</li> <li>• Changes in high-speed counter present value can be measured.</li> <li>• High-speed counter frequency can be measured.</li> </ul>	
Program	Program capacity	5 Ksteps	

**FQM1-MMA21 (Analog I/O)**

Item		Specifications	
I/O	Pulse inputs	Pulse inputs: 2 (compatible with Servo Drivers with absolute encoders)	40-pin connector
	Analog I/O	<ul style="list-style-type: none"> <li>Analog inputs: 1 (-10 to 10 V, 0 to 5 V, 1 to 5 V, and 4 to 20 mA), conversion speed: 40 μs/input</li> <li>Analog outputs: 2 (-10 to 10 V, 0 to 10 V, 0 to 5 V, and 1 to 5 V), conversion speed: 40 μs/output</li> </ul>	
	General-purpose I/O	General-purpose inputs: 12 General-purpose outputs: 8	26-pin connector
Functions	Analog output	<ul style="list-style-type: none"> <li>Slope</li> <li>Output hold</li> <li>Offset/gain adjustment</li> </ul>	
	Analog input	<ul style="list-style-type: none"> <li>Offset/gain adjustment</li> </ul>	
Program	Program capacity	5 Ksteps	

**Nomenclature**

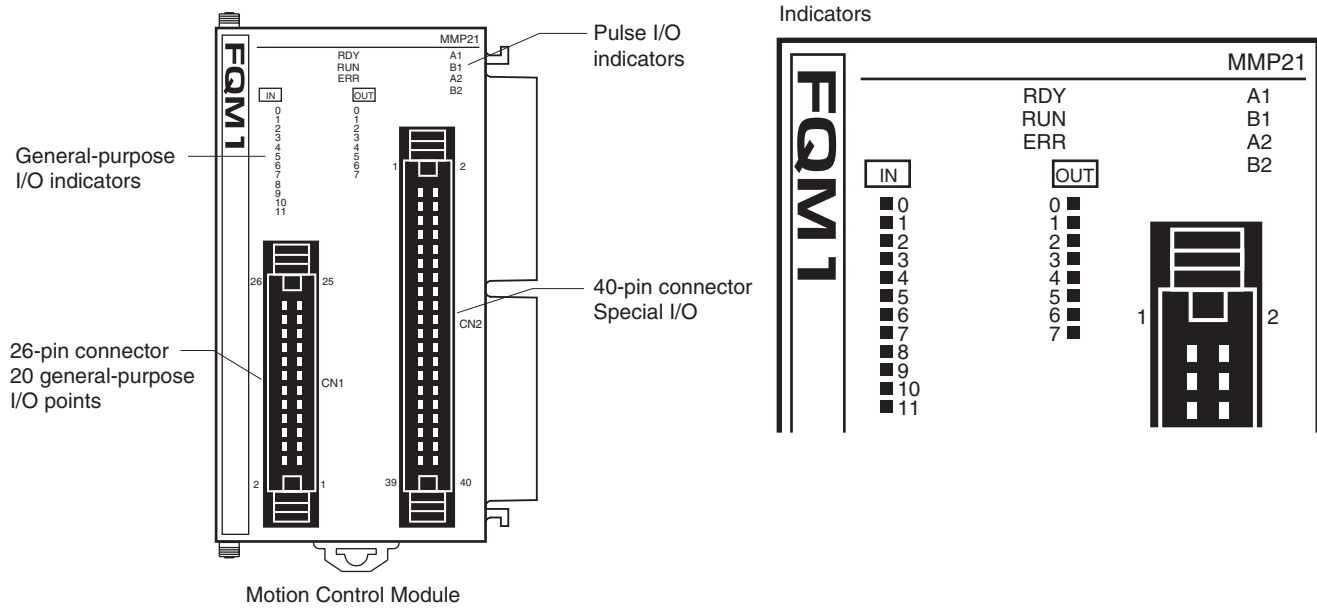

**Indicators**

Indicator	Color	Name	Status	Meaning
RDY	Green	Module operation	Lit	Module operating normally.
			Not lit	Module error (e.g., WDT error)
RUN	Green	Program execution	Lit	Executing internal Module program
			Not lit	Internal Module program stopped.
ERR	Red	Module error	Lit	Fatal error.
			Flashing	Non-fatal error.
			Not lit	Module operating normally.
IN0 to IN11	Yellow	Inputs	Lit	Input signal ON
			Not lit	Input signal OFF
OUT0 to OUT7	Yellow	Outputs	Lit	Output signal ON
			Not lit	Output signal OFF
A1/B1 A2/B2	Yellow	Pulse inputs	Lit	Input signal ON
			Not lit	Input signal OFF

**Note** IN0 to IN 11, OUT0 to OUT7, and A1 to B2 are all controlled by hardware.



**Performance Specifications**

Item		Specifications
Control method		Stored program
I/O control method		Cyclic scan
Programming language		Ladder diagram
Instruction length		1 to 7 steps per instruction
Number of instructions		Approx. 270
Instruction execution time	Basic instructions	0.1 $\mu$ s min.
	Special instructions	0.3 $\mu$ s min.
Common processing time (overhead)	MMP21	Sync Mode: 250 $\mu$ s ASync Mode: 190 $\mu$ s
	MMA21	Sync Mode: 340 $\mu$ s ASync Mode: 280 $\mu$ s Each analog input when analog output is disabled: 190 $\mu$ s When analog output disabled: 230 $\mu$ s
Program capacity	Ladder	5 Ksteps
	Comment storage	None
Number of tasks		Cyclic tasks: 1, interrupt tasks: 50
Subroutines		256
JMP instructions		256
Number of basic I/O		20 per Module
CIO Area	Input Bit Area	12 bits (CIO 0000): CIO 0000.00 to CIO 0000.11
	Output Bit Area	8 bits (CIO 0001): CIO 0001.00 to CIO 0001.07
	Cyclic Refresh Bit Area	160 bits (10 words): CIO 0100 to CIO 0109 Input refresh for Coordinator to Motion Control Module: CIO 0100 to CIO 0104 Output refresh for Motion Control Module to Coordinator Module: CIO 0105 to CIO 0109
	Synchronous Data Link Bit Area	320 bits (20 words): CIO 0200 to CIO 0219 Sent from Coordinator Module: CIO 0200 to CIO 0203 Sent from Motion Control Module #1: CIO 0204 to CIO 0207 Sent from Motion Control Module #2: CIO 0208 to CIO 0211 Sent from Motion Control Module #3: CIO 0212 to CIO 0215 Sent from Motion Control Module #4: CIO 0216 to CIO 0219
Work Area	CIO Area	3,584 bits: CIO 0002 to CIO 0099, CIO 0110 to CIO 0199, and CIO 0220 to CIO 0255
	WR Area	4,096 bits: W000 to W255
Auxiliary Area	Read/Write	Read only: 5,568 bits, A000 to A099 and A200 to A447 Read/write: 3,232 bits, A448 to A649
	Error Log	100 words: A100 to A199 (20 records)
Temporary Area		16 bits: TR0 to TR15
Holding Area		None
Timer Area		256 timers: T0000 to T0255 (1-ms, 10-ms, and 100-ms timers)
Counter Area		256 counters C0000 to C0255 (decrementing counters and reversible counters) <b>Note</b> Status not retained when power turned OFF.
DM Area	Read/write (not retained)	30 Kwords: D00000 to D29999 (Status not retained when power is turned OFF.)
	Read/write (retained)	2,768 words: D30000 to D32767 (Retained by super capacitor)
System Setup		System Setup Area (Coordinator Module/Motion Control Module settings), motion parameter setting area
Index Registers		IR0 and IR1 used with JSB instruction
Data Registers		None
Interrupt Functions	Input interrupts	4 (with adjustment down mode)
	Timer interrupts	1(Scheduled or one-shot interrupt)

Item		Specifications		
Power interruption hold function (momentary power interruption)		Super capacitor		
Memory backup		Super capacitor backup	Error log, part of DM Area (backup for momentary power interruptions)	
		Flash memory	User programs, System Setup	
Trace memory		4,000 words		
Peripheral servicing		Event requests from Coordinator Module		
Self-diagnosis function		CPU errors (WDT) and memory errors		
Program check		Programs checked from the CX-Programmer.		
Super-capacitor backup time		Approximately 100 hours at 25°C		
Clock		None		
Individual functions	High-speed counters	Phase pulse inputs, Up/down pulse inputs, Pulse + direction pulse inputs (50 kHz/1 MHz)		FQM1-MMP21 (pulse I/O)
		Phase differential inputs (50 kHz/500 kHz; phase differential × 4, 2 MHz)		
	High-speed pulse outputs	CW and CCW (1 MHz: Line-driver)		
		One-shot pulse output		
	High-speed counters	Single phase pulse inputs/Up/down pulse inputs /Pulse + direction pulse inputs (50 kHz/1 MHz)		FQM1-MMA21 (analog I/O)
		Phase differential inputs (50 kHz/500 kHz; phase differential × 4, 2 MHz)		
	Analog input	Conversion speed: 40 μs/input		
		Resolution: -10 to 10 V: 1/16,000; 0 to 10 V: 1/8,000; 0 to 5 V: 1/4,000; 1 to 5 V: 1/4,000; 4 to 20 mA: 1/4,000		
	Analog outputs	Conversion speed: 40 μs/output		
		Resolution: -10 to 10 V: 1/10,000; 0 to 10 V/0 to 5 V/1 to 5 V: 1/4,000		

**I/O Specifications**

**General-purpose I/O Specifications**

**Common Specifications for FQM1-MMP21 (Pulse I/O) and FQM1-MMA21 (Analog I/O)**

Item		Specifications	
Inputs	Number of inputs	12 inputs	
	Input voltage	20.4 to 26.4 V	
	Input response	Interrupt input (4 points with one common)	ON delay time: 30 μs OFF delay time: 0.2 ms max.
Normal input (8 points with one common)		ON delay time: 100 μs OFF delay time: 1 ms max.	
Outputs	Number of outputs	8 outputs	
	Output type	Transistor (NPN)	
	Switching capacity	4.5 to 30 V DC, 0.3 A per output	
	ON delay time	0.1 ms max.	
	OFF delay time	1 ms max.	

Pulse I/O Specifications

**FQM1-MMP21 (Pulse I/O)**

Item		Specifications		
Pulse inputs	Number of counters	2		
	Counter operations	Linear counter and circular counter		
	Input signals	Two words each for phase A, phase B, and phase Z.		
	Signal levels	24 V DC, line-driver		
	Input method	Phase differential ×1 Phase differential ×2 Phase differential ×4 Increment/decrement Pulse + direction		
	Counting speed	Voltage	50 k Hz	
		Line-driver	50 k Hz/500k Hz (phase differential × 4, 2 MHz)	
Absolute Servo Driver interfaces	2 SEN output specifications: 5 V PNP output, output current: 5 mA When SEN signal is output to Servo Driver, Servo Driver will transmit the number of encoder's rotations to this Module. After that, it transmits pulse train corresponding to displacement of the number of turns to the Module.			
Pulse outputs	Number of outputs	2		
	Output signal	CW/CCW		
	Signal levels	Line-driver (equivalent to AM26LS31) Max. output current: 20 mA		
	Output speed	1 MHz		
One-shot pulse outputs	Number of outputs	2		
	Output type	Open collector (NPN)		
	Max. switching capacity	80 mA/5 to 24 V DC ± 10%		
	Min. switching capacity	7 mA/5 to 24 VDC ± 10%		
	Output pulse width	Set time ± 1 μs or 0.1% of set time		

Pulse Inputs and Analog I/O Specifications

FQM1-MMA21 (Analog I/O)

Item		Specifications		
Pulse inputs	Number of counters	2		
	Counter operations	Linear counter, circular counter		
	Input signals	Two words each for phase A, phase B, and phase Z.		
	Signal levels	CH1: 24 V DC, line-driver CH2: Line-driver		
	Input method	Phase differential ×1 Phase differential ×2 Phase differential ×4 Increment/decrement Pulse + direction		
	Counting speed	Voltage	50 kHz	
		Line-driver	50 k Hz/500k Hz (phase differential × 4, 2 MHz)	
Absolute Servo Driver interfaces	2 SEN output specifications: 5 V PNP output, output current 5 mA When SEN signal is output to Servo Driver, Servo Driver will transmit the number of encoder's rotations to this Module. After that, it transmits pulse train corresponding to displacement of the number of rotations to the Module.			
Analog input	Number of analog inputs	1		
	Input signals	Voltage inputs: -10 to 10 V 0 to 10 V 1 to 5 V 0 to 5 V	Current inputs: 4 to 20 mA	
	Resolution	-10 to 10 V: 14 bits (1/16,000) 0 to 10 V: 13 bits (1/8,000) 0 to 5 V: 12 bits (1/4,000) 1 to 5 V/4 to 20 mA: 12 bits (1/4,000)		
	Accuracy (FS)	Voltage input: ± 0.2% (23 ± 2°C) ± 0.4% (0 to 55°C)	Current input: ± 0.4% (23 ± 2°C) ± 0.6% (0 to 55°C)	
	Conversion speed	40 μs max./input Total: 1.5 ms max.		
Analog outputs	Number of outputs	2		
	Output signal	-10 to 10 V, 0 to 10 V, 1 to 5 V, 0 to 5 V		
	Resolution	-10 to 10 V: 14 bits (1/1,0000) 0 to 10 V: 12 bits (1/4,000) 0 to 5 V: 12 bits (1/4,000) 1 to 5 V: 12 bits (1/4,000)		
	Accuracy (FS)	± 0.3% (23 ± 2°C) ± 0.5% (0 to 55°C)		
	Conversion speed	40 μs max./output Total: 200 μs max.		

## 2-5 Dimensions

### FQM1-CM001 Coordinator Module

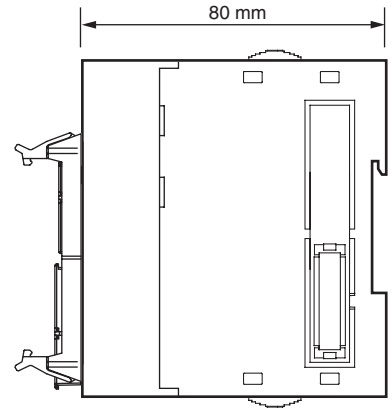
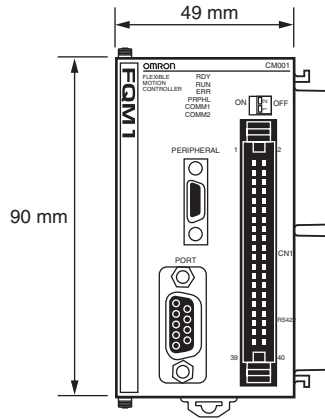

### FQM1-MMP21/MMA21 Motion Control Modules

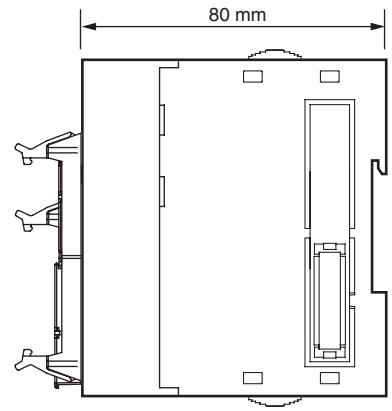
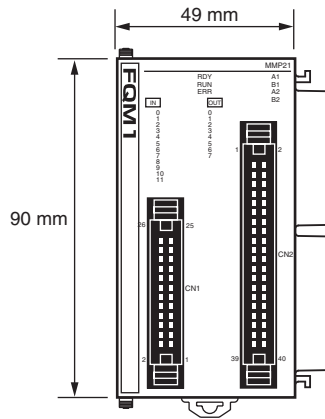

### FQM1-TER01 End Module

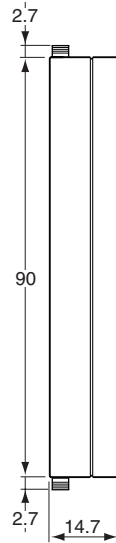

Power Supply Units

**CJ1W-PA202**

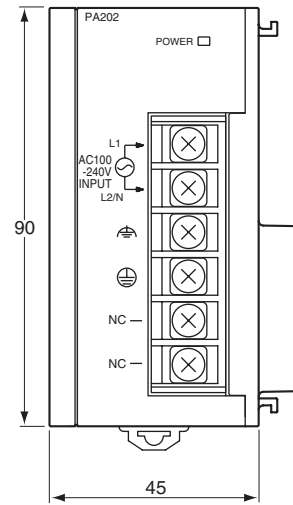
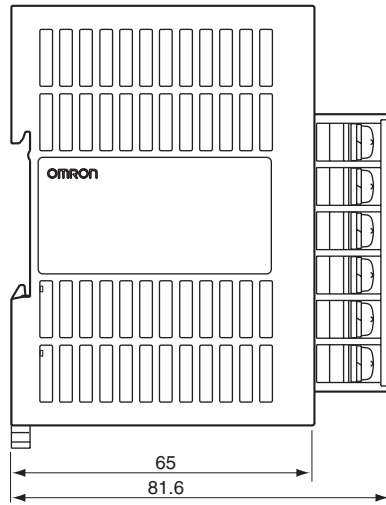

**CJ1W-PA205R**

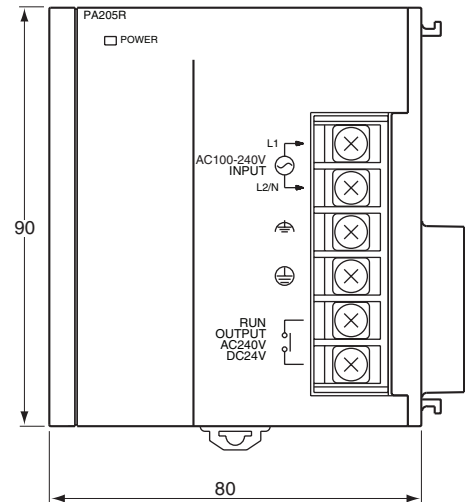
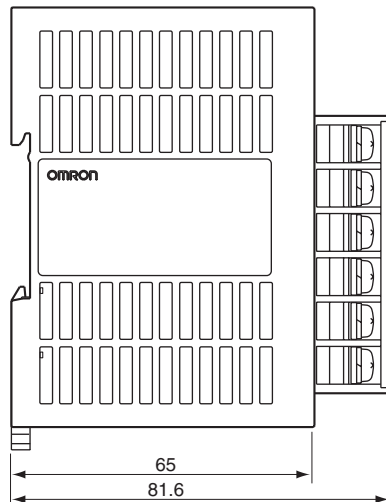

XW2B-80J7-1A Servo Relay Unit

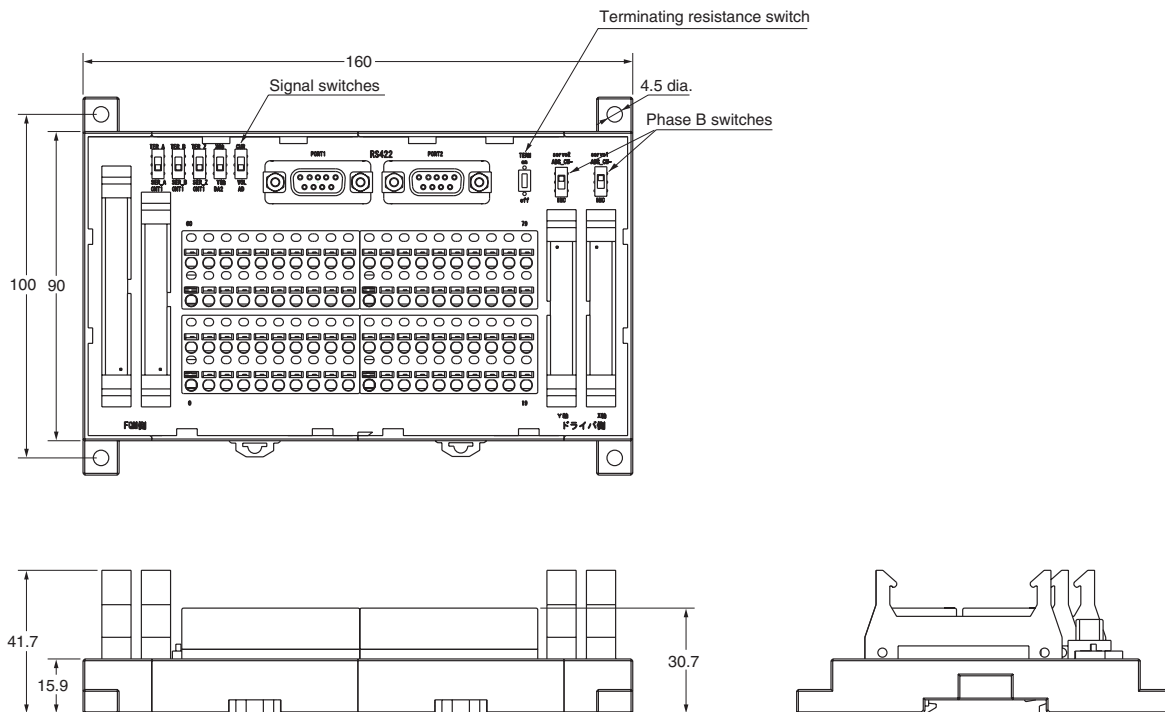

## 2-6 Module Current Consumption

The amount of current/power that can be supplied to the Modules mounted in the FQM1 is limited. Refer to the following tables when designing your system so that the total current consumption of the mounted Modules does not exceed the maximum current for each voltage system and the total power consumption does not exceed the maximum for the Power Supply Unit.

### Maximum Current and Maximum Total Power Consumption

The following table shows the maximum currents and power that can be supplied by Power Supply Units to the Controller.

Power Supply Unit	Max. current consumption			Max. total power consumption
	5-V system (internal logic)	24-V system (analog)	24-V system (service)	
CJ1W-PA202	2.8 A	0.4 A	None	14 W
CJ1W-PA205R	5.0 A	0.8 A	None	25 W

### Current Consumption for Each Module

#### Current Consumption for 5-V System

Name	Model	5-V system current consumption (A)
Coordinator Module <b>Note</b> The listed value includes the current consumption for the CX-Programmer.	FQM1-CM001	0.47 (See note.)
End Module	FQM1-TER01	Included in Coordinator Module current consumption

**Note** The current consumption increases by 0.15 A/Module if NT-AL001 Link Adapters are used.

**Motion Control Modules**

Name	Type	Model	5-V system current consumption (A)
Motion Control Module	Pulse I/O	FQM1-MMP21	0.836
	Analog I/O	FQM1-MMA21	0.843

**Current Consumption for 24-V Systems**

Name	Type	Model	24-V system current consumption (A)
Motion Control Module	Analog I/O	FQM1-MMA21	0.104

**Example Calculation of Current and Power Consumption**

Example for CJ1W-PA202 Power Supply Unit with the Following Modules Mounted

Name	Model	Quantity	Voltage system	
			5 V	24 V
Coordinator Module	FQM1-CM001	1	0.47 A	---
Motion Control Module	FQM1-MMP21	1	0.836 A	---
	FQM1-MMA21	1	0.843 A	0.104 A
Current consumption	Calculation		$0.47 + 0.836 + 0.843$	0.104 A
	Result		2.15 A ( $\leq 2.8$ A)	$0.104 \times 24$ V = 2.5 W
Power consumption	Calculation		$2.15 \times 5$ V = 10.75 W	---
	Result		$10.75 + 2.5 = 13.75$ W ( $\leq 14$ W)	

**Combining Power Supply Units and Motion Control Modules**

The following table shows the Power Supply Units that can be connected for different numbers of Motion Control Modules.

Number of axes	Number of connected Motion Control Modules		Power Supply Unit
	FQM1-MMP21	FQM1-MMA21	
2	1	0	CJ1W-PA202 (or CJ1W-PA205R)
	0	1	
4	2	0	
	1	1	
	0	2	
6	3	0	CJ1W-PA205R
	2	1	
	1	2	
	0	3	
8	4	0	
	3	1	
	2	2	
	1	3	
	0	4	Not possible (See note.)

**Note** These combinations are not possible because the current consumption exceeds the capacity of the Power Supply Unit.



## 2-7 Memory Block Diagram

Coordinator Module and Motion Control Module memory has the following block configurations.

- I/O Memory Area: Memory accessible from user programs.
- User Memory (UM): User programs and parameter area (See note 1.)

The following tables show the backup methods for these memory areas.

- Coordinator Modules

Area	Backup method
User memory	Flash memory
I/O memory area (part of DM Area)	Flash memory

- Motion Control Modules

Area	Backup method
User memory	Flash memory
I/O memory area (part of DM Area)	Super capacitor

### Areas Backed Up by Super Capacitors

Data backed up by super capacitors is lost if the super capacitor voltage drops.

### Areas Backed Up to Flash Memory

Data backed up to flash memory is not lost if the super capacity voltage drops. Data transferred from the CX-Programmer or edited online and written to the user program or parameters in the user memory is automatically backed up to flash memory. This means that user memory data (both user program and parameter area data) is not lost if the super capacitor voltage drops.

### **Coordinator Module/Motion Control Module**

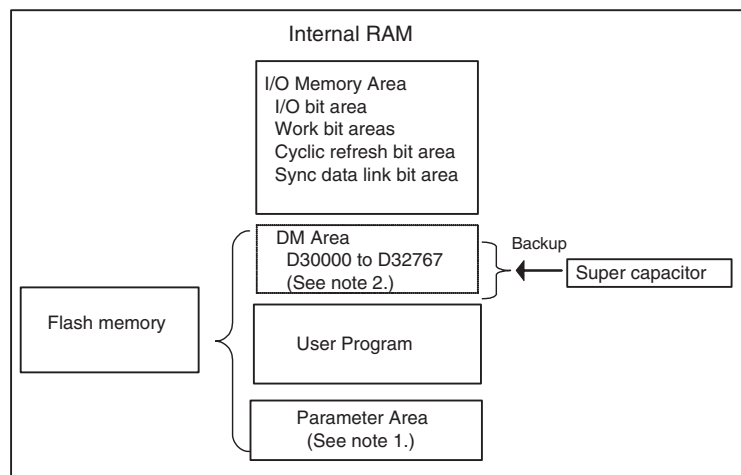

- Note**
- (1) The parameter area stores the Coordinator Module system information, such as the System Setup.
  - (2) Data transferred to the Coordinator Module, e.g., from the CX-Programmer, is saved to flash memory. Motion Control Module data is backed up only by the super capacitor.



# SECTION 3

## Installation and Wiring

This section describes how to install and wire the FQM1.

3-1	Installation . . . . .	50
3-1-1	Installation and Wiring Precautions . . . . .	50
3-1-2	Installation in a Control Panel . . . . .	53
3-1-3	Assembled Appearance and Dimensions . . . . .	54
3-1-4	Connecting FQM1 Components . . . . .	56
3-1-5	DIN Track Installation . . . . .	57
3-2	Wiring . . . . .	60
3-2-1	Wiring Power Supply Units . . . . .	60
3-2-2	RS-232C Port Wiring . . . . .	64
3-3	Wiring Module Connectors . . . . .	67
3-3-1	Connector Pin Arrangement . . . . .	67
3-3-2	External Connection Diagrams . . . . .	70
3-3-3	Wiring Examples . . . . .	71
3-3-4	Wiring Methods . . . . .	74
3-4	Wiring Servo Relay Units . . . . .	75
3-5	List of FQM1 Connecting Cables . . . . .	83
3-6	Wiring Precautions . . . . .	85
3-6-1	Reducing Electrical Noise . . . . .	85
3-6-2	Connecting I/O Devices . . . . .	87

## 3-1 Installation

### 3-1-1 Installation and Wiring Precautions

Be sure to consider the following factors when installing and wiring the FQM1 to improve the reliability of the system and make the most of the FQM1's functions.

#### Ambient Conditions

Do not install the FQM1 in any of the following locations.

- Locations subject to ambient temperatures lower than 0°C or higher than 55°C.
- Locations subject to drastic temperature changes or condensation.
- Locations subject to ambient humidity lower than 10% or higher than 90%.
- Locations subject to corrosive or flammable gases.
- Locations subject to excessive dust, salt, or metal filings.
- Locations that would subject the FQM1 to direct shock or vibration.
- Locations exposed to direct sunlight.
- Locations that would subject the FQM1 to water, oil, or chemical reagents.

Be sure to enclose or protect the FQM1 sufficiently in the following locations.

- Locations subject to static electricity or other forms of noise.
- Locations subject to strong electromagnetic fields.
- Locations subject to possible exposure to radioactivity.
- Locations close to power lines.

#### Installation in Cabinets or Control Panels

##### Temperature Control

When the FQM1 is being installed in a cabinet or control panel, be sure to provide proper ambient conditions as well as access for operation and maintenance.

The ambient temperature within the enclosure must be within the operating range of 0°C to 55°C. When necessary, take the following steps to maintain the proper temperature.

- Provide enough space for good air flow.
- Do not install the FQM1 above equipment that generates a large amount of heat such as heaters, transformers, or high-capacity resistors.
- If the ambient temperature exceeds 55°C, install a cooling fan or air conditioner.

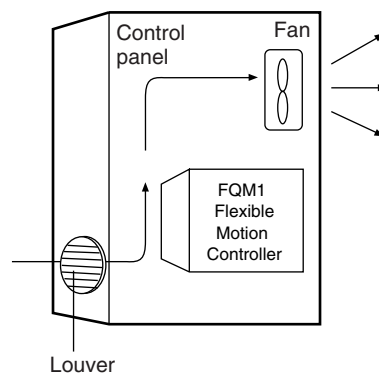

##### Accessibility for Operation and Maintenance

- To ensure safe access for operation and maintenance, separate the FQM1 as much as possible from high-voltage equipment and power equipment.

**Improving Noise Resistance**

- The FQM1 will be easiest to install and operate if it is mounted at a height of about 1.0 to 1.6 m.
- Do not mount the FQM1 in a control panel containing high-voltage equipment.
- Install the FQM1 at least 200 mm away from power lines.

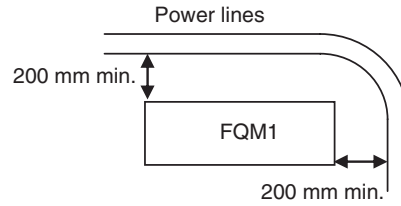

- Ground the mounting plate between the FQM1 and the mounting surface.

FQM1 Orientation

- The FQM1 must be mounted in an upright position to provide proper cooling.

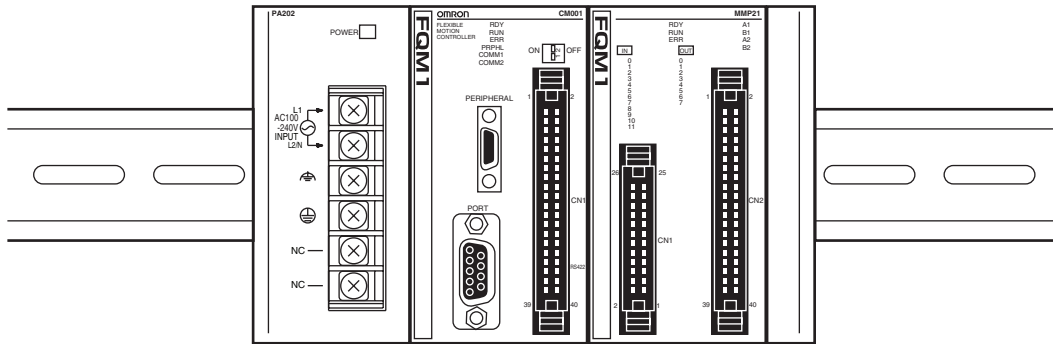

- Do not install the FQM1 in any of the following positions.

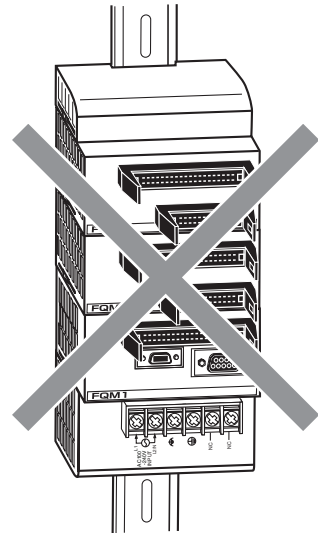
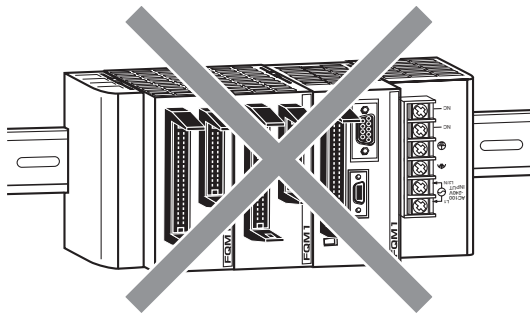
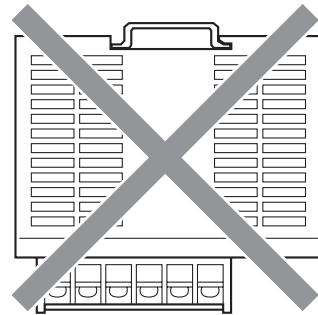
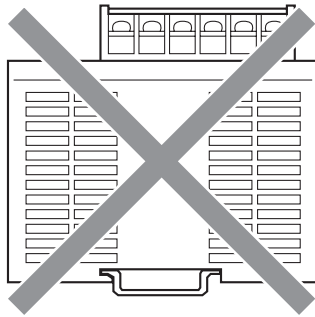

### 3-1-2 Installation in a Control Panel

The FQM1 must be mounted inside a control panel on DIN Track.

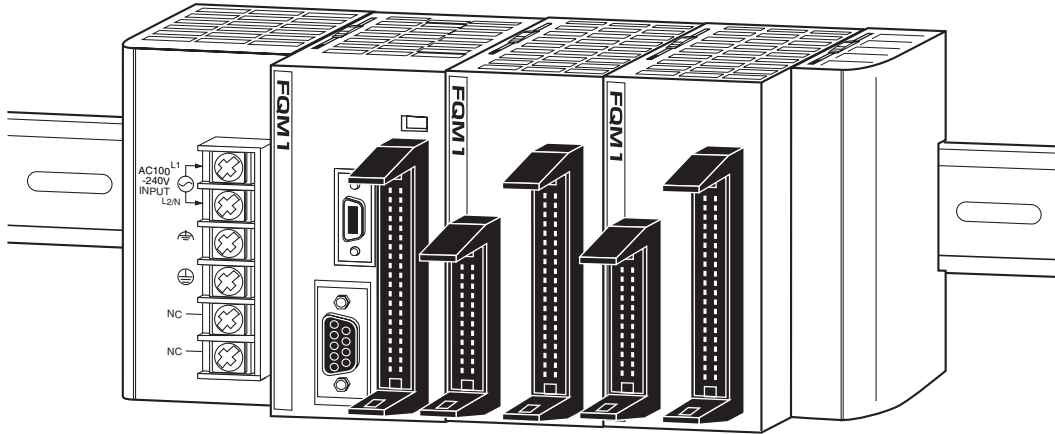

**Note** The FQM1 must be mounted on DIN Track. It cannot be mounted with screws.

#### Wiring Ducts

Use wiring ducts to wire the FQM1's built-in I/O. Install the wiring ducts to facilitate wiring the built-in I/O. It is handy to have the duct at the same height as the FQM1.

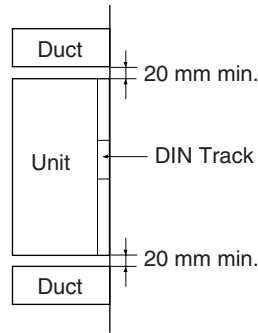

#### Wiring Duct Example

The following example shows the proper installation of wiring ducts.

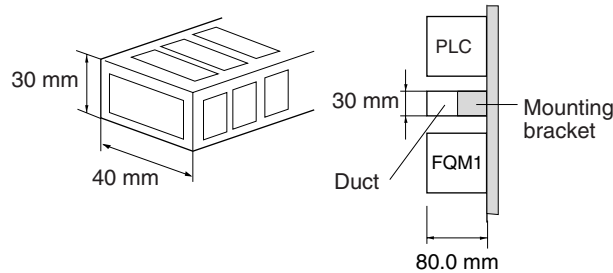

**Note** Tighten terminal block screws and cable screws to the following torques.

- Terminal Screws
- M4: 1.2 N·m
- M3: 0.5 N·m

**Routing Wiring Ducts**

Install the wiring ducts at least 20 mm away from the FQM1 and any other objects, (e.g., ceiling, wiring ducts, structural supports, and devices) to provide enough space for air circulation and replacement of Modules.

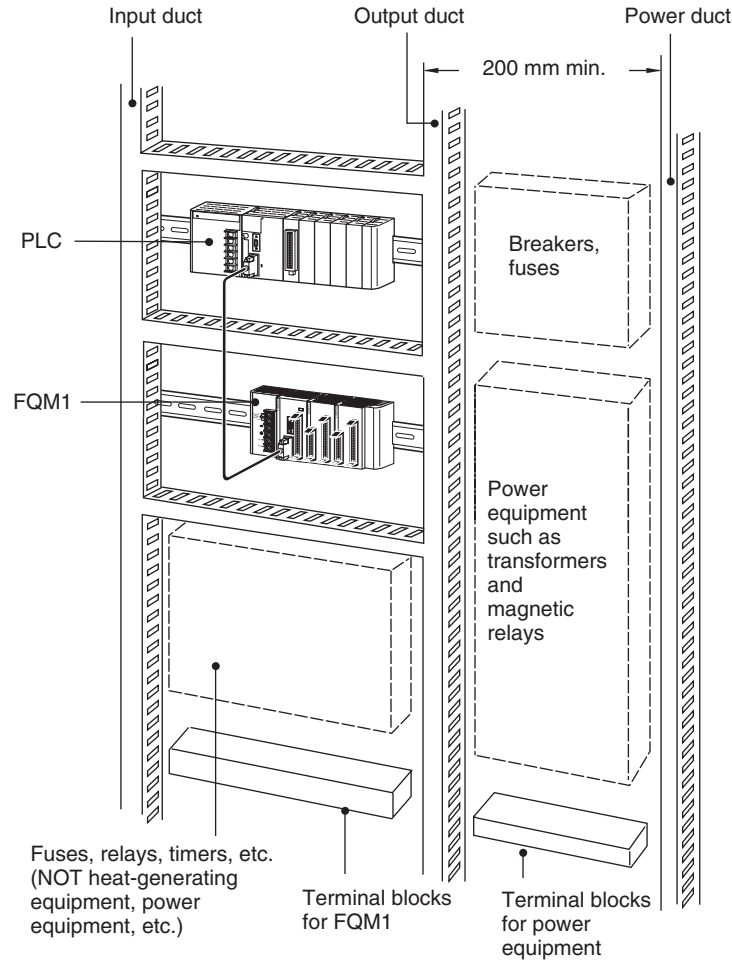

**3-1-3 Assembled Appearance and Dimensions**

The Modules that make up the FQM1 are connected to each other, and an End Module is connected to the right end.

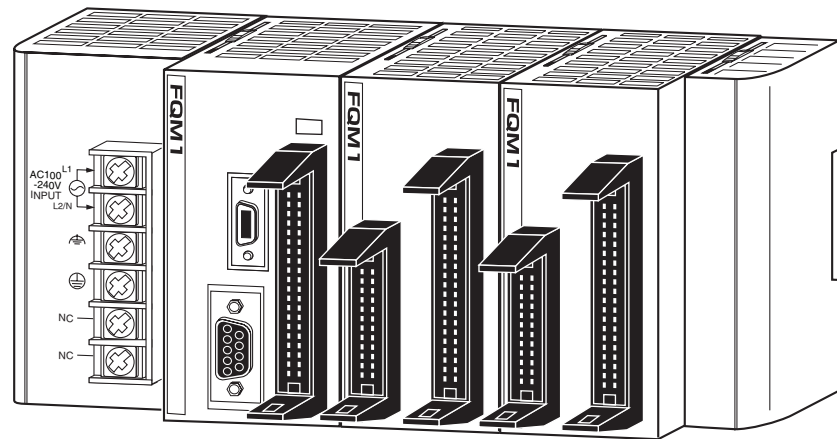



**Assembled Dimensions**

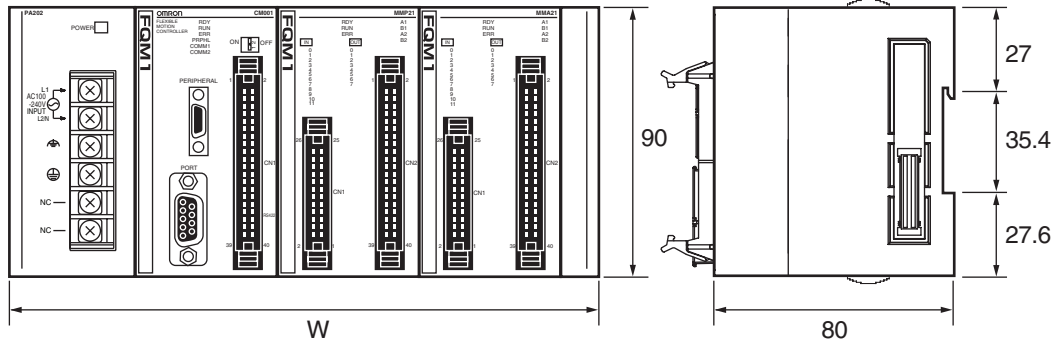

$$W = a + 49 + 49 \times n^* + 14.7$$

\* n is the number of connected Motion Control Modules (Up to 4 can be connected.)

Power Supply Unit width: "a" mm

Name	Model	Specifications	Unit width
Power Supply Unit	CJ1W-PA202	100 to 240 V AC, 14 W	45 mm
	CJ1W-PA205R	100 to 240 V AC, 25 W	80 mm

Coordinator Module width: 49 mm

Name	Model	Module width
Coordinator Module	FQM1-CM001	49 mm

Motion Control Module width: 49 mm

Name	Model	Module width	
Motion Control Module	Pulse I/O	FQM1-MMP21	49 mm
	Analog I/O	FQM1-MMA21	

End Module width: 14.7 mm

Name	Model	Module width
End Module	FQM1-TER01	14.7 mm

**Installation Dimensions**

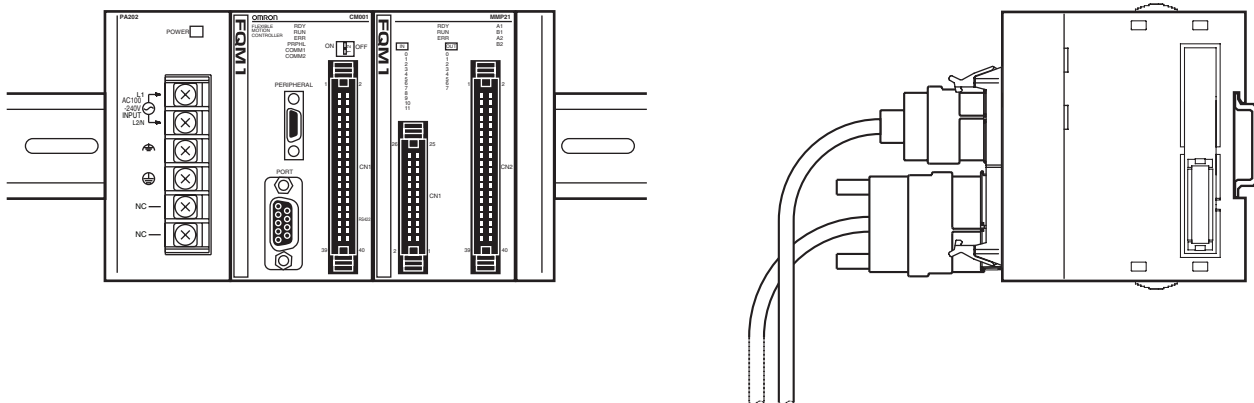

**Installation Height**

The installation height of the FQM1 varies from 115 to 165 mm. When a CX-Programmer or connecting cables are connected, however, even greater height is required. Allow sufficient depth in the control panel containing the FQM1.

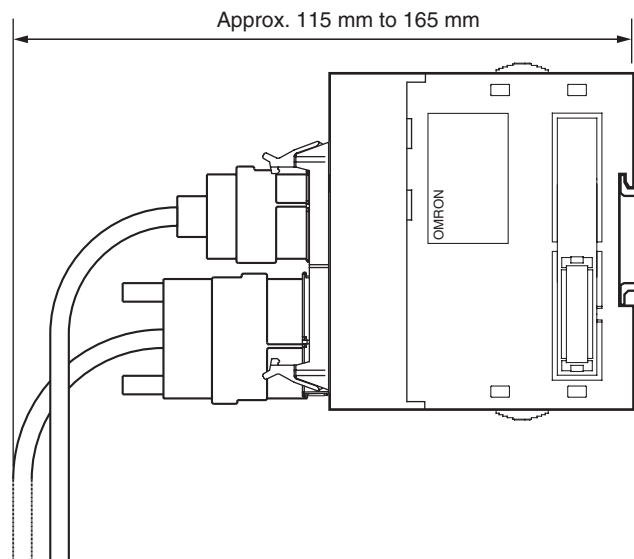

**3-1-4 Connecting FQM1 Components**

The Modules that make up the FQM1 can be connected simply by pressing the Modules together and locking the sliders. The End Module is connected on the far right side of the FQM1.

- 1,2,3...**
1. Insert the two hooks on the top of the Module to the hook holes on the other Module, and join the Modules so that the connectors fit exactly.

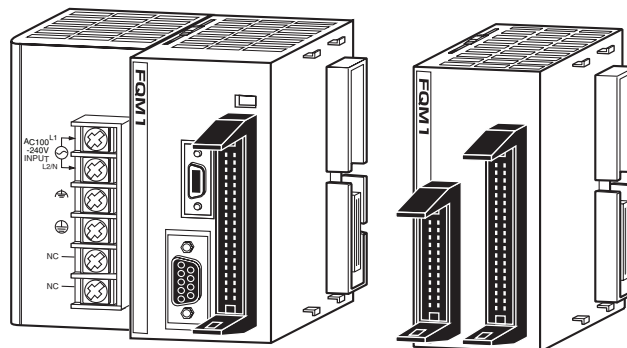

2. Move the yellow sliders at the top and bottom of each Module until they click into place to lock the Modules together.

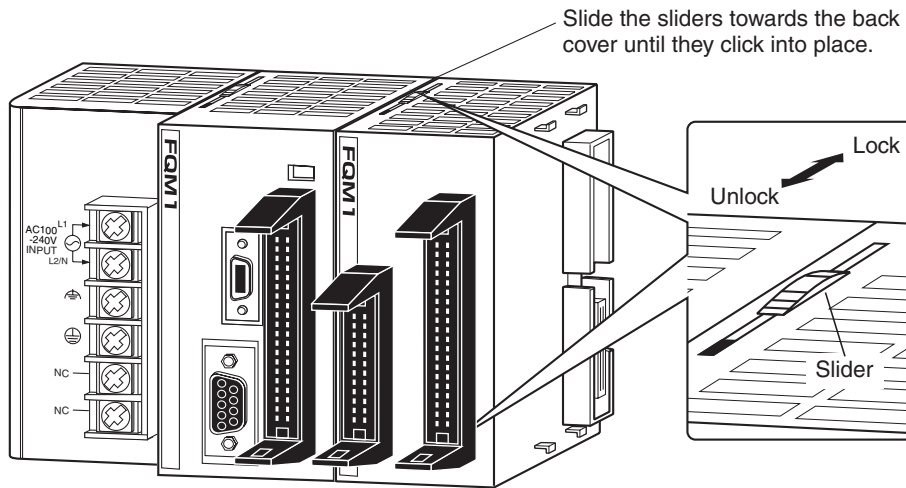

**Note** If the locking tabs are not secured properly, the FQM1 may not function properly. Be sure to slide the locking tabs until they are securely in place.

3. Attach the End Module to the Module on the far right side of the FQM1.

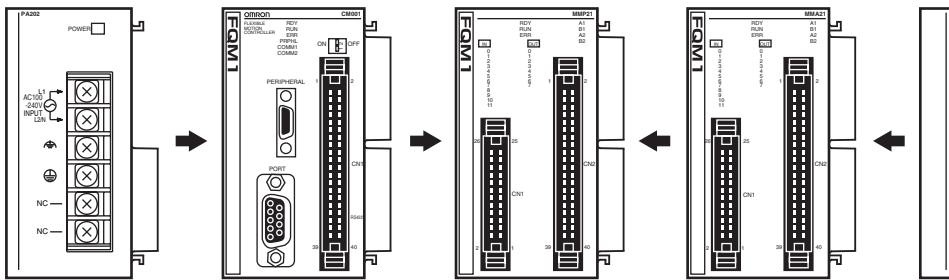

### 3-1-5 DIN Track Installation

Use the following procedure to install the FQM1 on DIN Track.

- 1,2,3...**
1. Release the pins on the backs of the Modules.

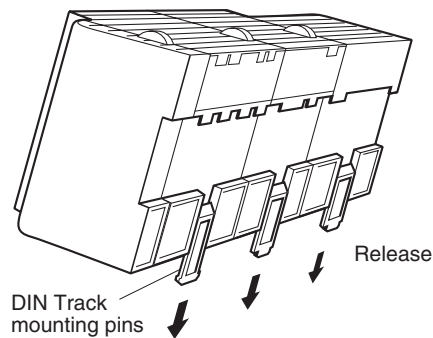

2. Fit the back of the FQM1 onto the DIN Track by inserting the FQM1 onto the top of the Track and then pressing in at the bottom of the FQM1, as shown below.

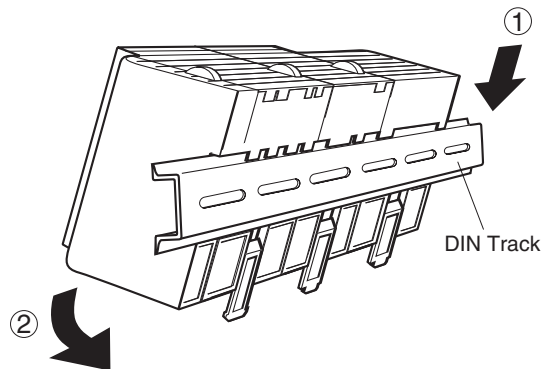

3. Lock the pins on the backs of the Modules.

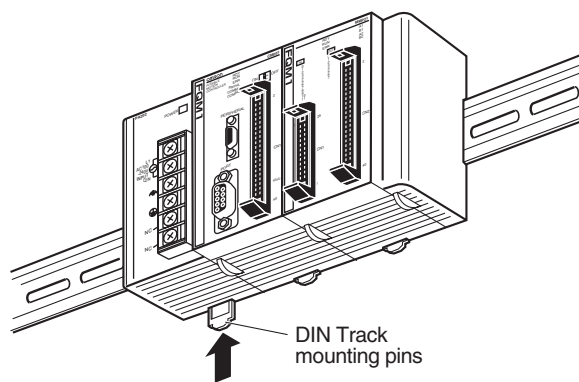

4. Install a DIN Track End Plate on each end of the FQM1. To install an End Plate, hook the bottom on the bottom of the track, rotate the Plate to hook the top of the Plate on the top of the track, and then tighten the screw to lock the Plate in place.

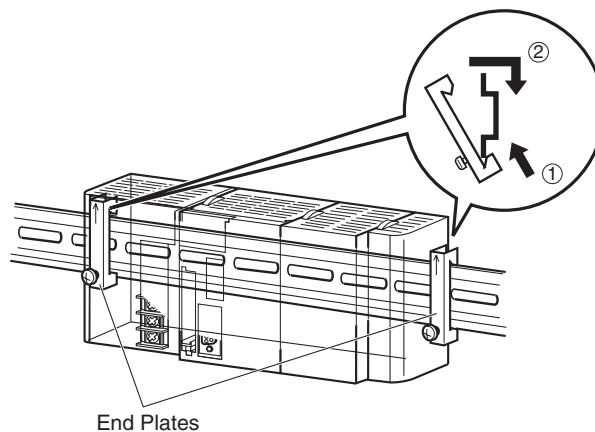

**DIN Track and Accessories**

Use the DIN Track and DIN Track End Plates shown below.

• **DIN Track**

Model numbers: PFP-50N (50 cm), PFP-100N (100 cm), and PFP-100N2 (100 cm)

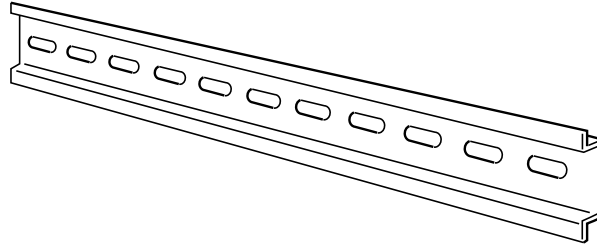

Secure the DIN Track to the control panel using M4 screws separated by 210 mm (6 holes) or less and using at least 3 screws. The tightening torque is 1.2 N·m.

**PFP-100N2 DIN Track**

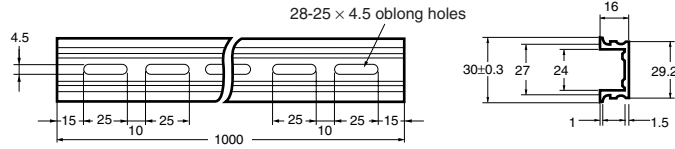

**PFP-100N/50N DIN Track**

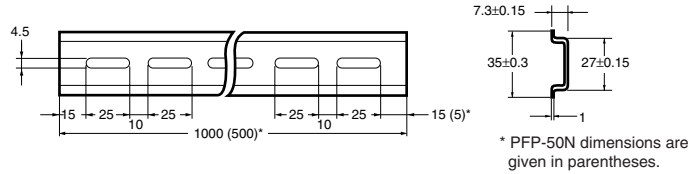

**DIN Track End Plates (2 Required)**

Model number: PFP-M

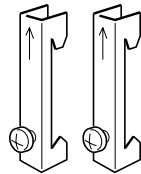

### 3-2 Wiring

#### 3-2-1 Wiring Power Supply Units

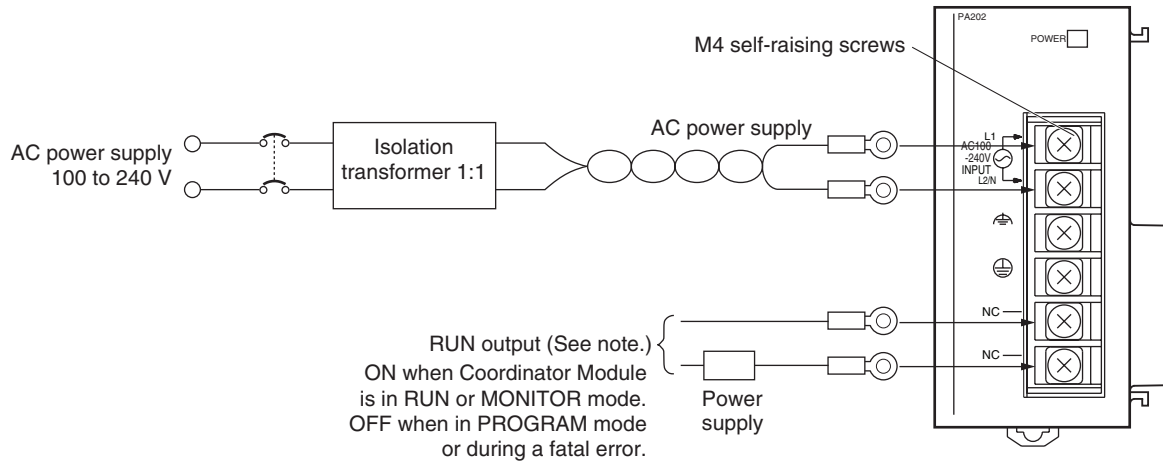

**Note** The RUN output function is provided only for the CJ1W-PA205R Power Supply Unit. It is not provided on the CJ1W-PA202 Power Supply Unit.

**AC Power Source**

- Supply 100 to 240 V AC.
- Keep the voltage fluctuations within the specified range.

Supply voltage	Allowable voltage fluctuations
100 to 240 V AC	85 to 264 V AC

- If one power supply phase of the equipment is grounded, connect the grounded phase side to the L2/N terminal.

**Isolation Transformer**

The FQM1's internal noise isolation circuits are sufficient to control typical noise in power supply lines, but noise between the FQM1 and ground can be significantly reduced by connecting a 1-to-1 isolation transformer. Do not ground the secondary coil of the transformer.

**Power Supply Capacity**

The power consumption will be 100 VA max. for the CJ1W-PA205R and 50 VA for the CJ1W-PA202, but there will be a surge current of at least 5 times the max. current when the power is turned ON.

**Terminal Screws and Crimp Terminals**

The terminals on the Power Supply Unit use M4, self-raising terminal screws.

- Note**
- (1) Use crimp terminals for wiring.
  - (2) Do not connect bare stranded wires directly to terminals.
  - (3) Tighten the terminal block screws to a torque of 1.2 N·m. Use M4 crimp terminals for AC power supplies.

**Crimp Terminals for AC Power Supply**

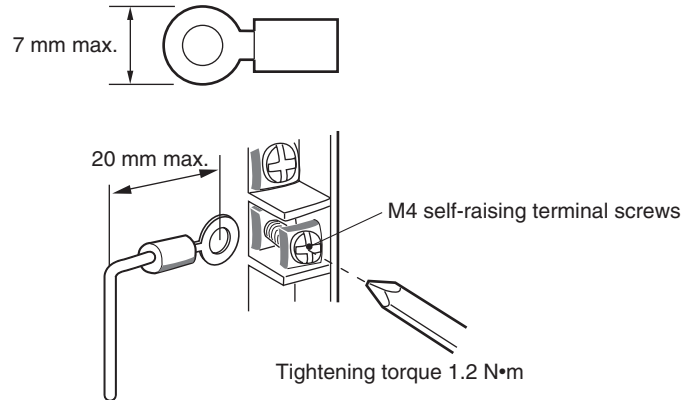

**Caution** Tighten AC power supply terminal block screws to a torque of 1.2 N·m. Loose screws may cause shorts, malfunctions, or fire.

- Note**
- (1) Supply power to all of the Power Supply Units from the same source.
  - (2) Do not remove the protective label from the top of the Power Supply Unit until the wiring has been completed. This label prevents wire strands and other foreign matter from entering the Unit during wiring procedures.
  - (3) Do not forget to remove the label from the top of the Power Supply Unit after wiring the Unit. The label will block air circulation needed for cooling.

**Grounding**

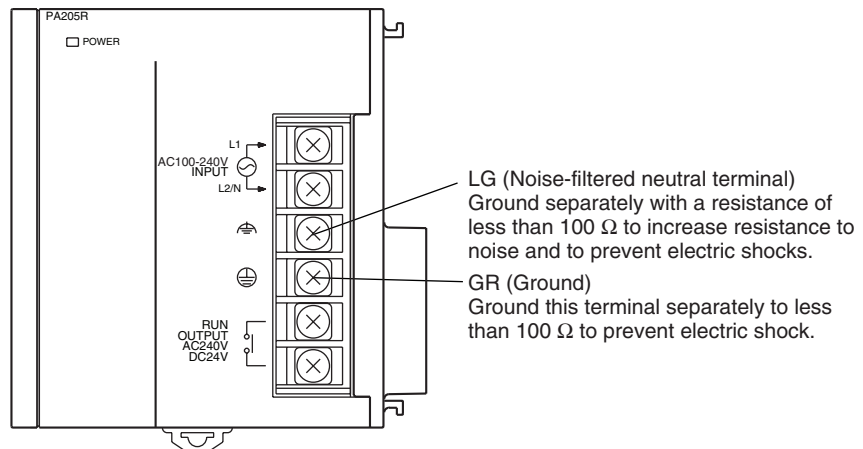

- GR is the ground terminal. To help prevent electric shock, ground this terminal to less than 100 Ω and use special ground wire (minimum cross-sectional area of 2 mm<sup>2</sup>).

- LG is a noise-filtered neutral terminal. If noise is a significant source of errors and to prevent electrical shocks, connect the line ground terminal to the ground terminal and ground both with a ground resistance of less than  $100\ \Omega$  or less.
- If connecting the line ground and ground terminals, always ground both to less than  $100\ \Omega$  to prevent electrical shock.
- The ground wire should not be more than 20 m long.
- The FQM1 is designed to be mounted so that it is isolated (separated) from the mounting surface to protect it from the effects of noise in the installation environment (e.g., the control panel).

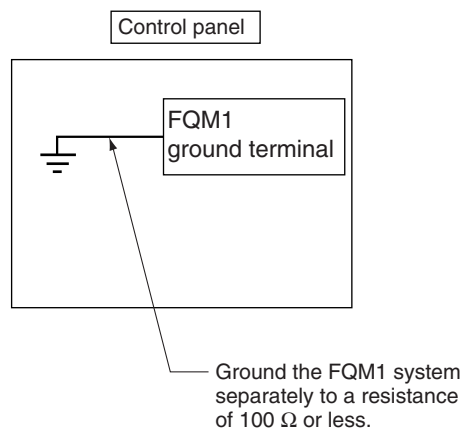

- Do not share the FQM1's ground with other equipment or ground the FQM1 to the metal structure of a building. Doing so may worsen operation.



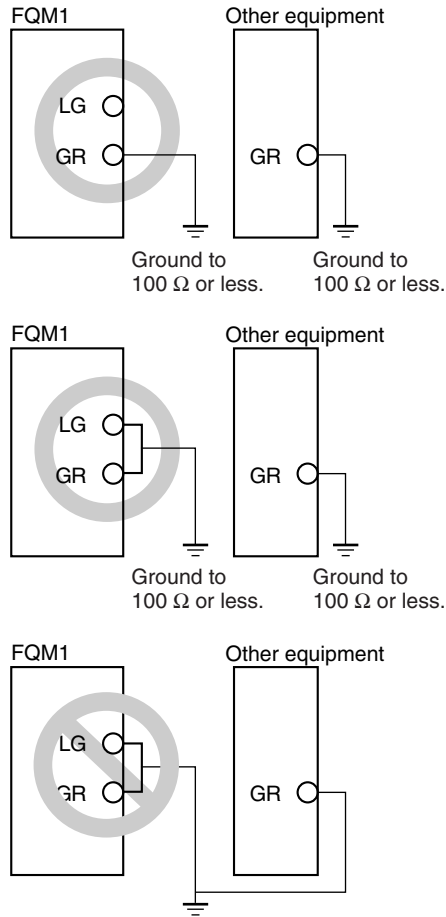

**Terminal Screws and Crimp Terminals**

The terminals on the Power Supply Unit use M4 self-raising terminal screws.

- Note**
- (1) Use crimp terminals for wiring.
  - (2) Do not connect bare stranded wires directly to terminals.
  - (3) Tighten the terminal block screws to a torque of 1.2 N·m.
  - (4) Use M4 crimp terminals for AC power supplies.

**Crimp Terminals for Ground Wire**

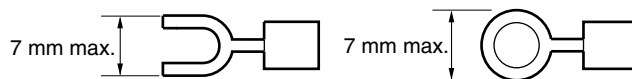

### 3-2-2 RS-232C Port Wiring

#### Connector Pin Arrangement

Pin No.	Signal	Name	Direction
1	FG	Protection earth	---
2	SD (TXD)	Send data	Output
3	RD (RXD)	Receive data	Input
4	RS (RTS)	Request to send	Output
5	CS (CTS)	Clear to send	Input
6	5V	Power supply	---
7	DR (DSR)	Data set ready	Input
8	ER (DTR)	Data terminal ready	Output
9	SG (0V)	Signal ground	---
Connector hood	FG	Protection earth	---

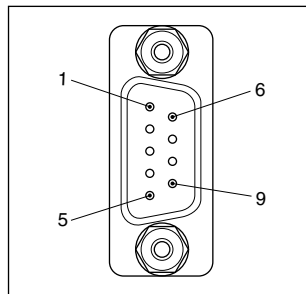

**Note** Do not connect the 5-V power supply on pin number 6 of the RS-232C port to any devices other than a NT-AL0001 Converter. Doing so may damage the external device and the Coordinator Module.

#### Connection Methods

##### 1:1 Connections with Personal Computers

##### Host Link Serial Communications Mode

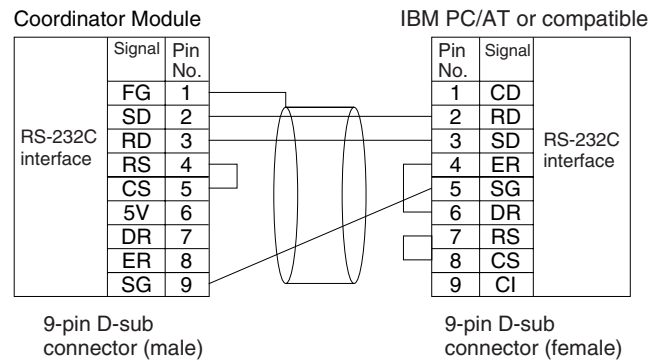

**Peripheral Bus (Toolbus) Serial Communications Mode**

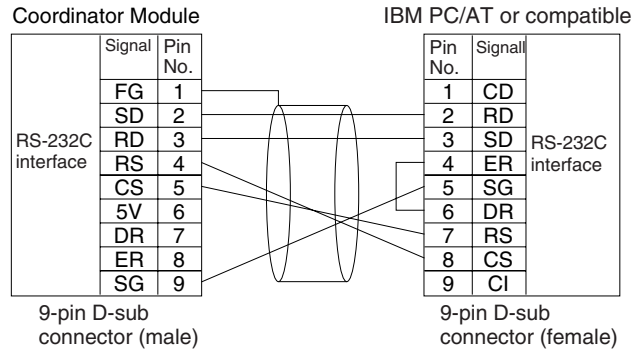

Use the following connectors and cables if making the RS-232C cable for RS-232C port connections.

**Applicable Connectors**

■ **Coordinator Module Connector**

Item	Model	Specifications	
Plug	XM2A-0901	9-pin male	Used together
Hood	XM2S-0911-E	9-pin, millimeter screws, static resistant	

■ **IBM PC/AT or Compatible Connector (9-pin, Male)**

Item	Model	Specifications	
Plug	XM2D-0901	9-pin female	Used together
Hood	XM2S-0913	9-pin, inch screws, static resistant	

■ **Connecting to an IBM PC/AT or Compatible**

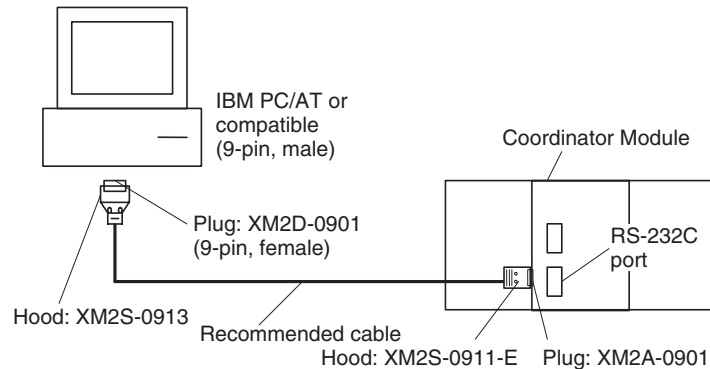

**Recommended Cables**

- Fujikura Ltd.: UL2464 AWG28 × 5P IFS-RVV-SB (UL product)  
AWG 28 × 5P IFVV-SB (non-UL product)
- Hitachi Cable, Ltd.: UL2464-SB (MA) 5P × 28AWG (7/0.127) (UL product)  
CO-MA-VV-SB 5P × 28AWG (7/0.127) (non-UL product)

**Note** Use the special cables provided from OMRON for all connections whenever possible. If cables are produced in-house, be sure they are wired correctly. External devices and the Coordinator Module may be damaged if general-purpose (e.g., computer to modem) cables are used or if wiring is not correct.

**Connection Example to Programmable Terminal (PT)**

**Direct Connection from RS-232C to RS-232C**

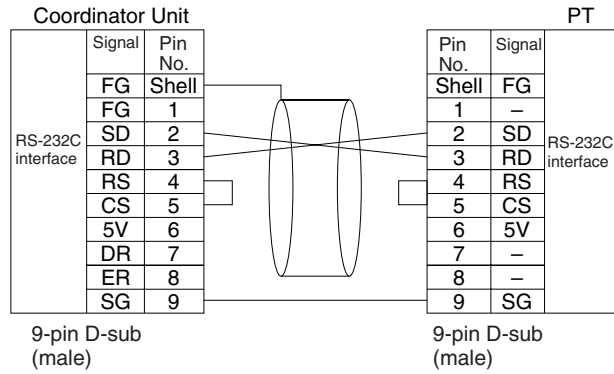
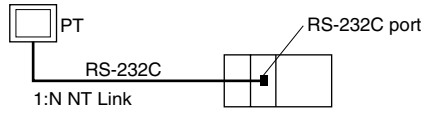

- Communications Mode: NT Link (1:N, N = 1 node only)
- OMRON Cables with Connectors: XW2Z200T (2 m)  
XW2Z500T (5 m)

**RS-232C Port Specifications**

Item	Specification
Communications method	Half duplex
Synchronization	Asynchronous
Baud rate	0.3, 0.6, 1.2, 2.4, 4.8, 9.6, 19.2, 38.4, or 57.6 kbps (See note.)
Transmission distance	15 m max.
Interface	EIA RS-232C
Protocol	Host Link, 1:N NT Link, No-protocol, or Peripheral Bus (Toolbus)

**Note** Baud rates for the RS-232C are specified only up to 19.2 kbps. The FQM1 supports serial communications from 38.4 kbps to 57.6 kbps, but some computers cannot support these speeds. Lower the baud rate if necessary.

### 3-3 Wiring Module Connectors

#### 3-3-1 Connector Pin Arrangement

The following tables provide the connector pin arrangement for FQM1 Modules.

#### **FQM1-CM001 Coordinator Module**

##### General-purpose I/O 40-pin Connector

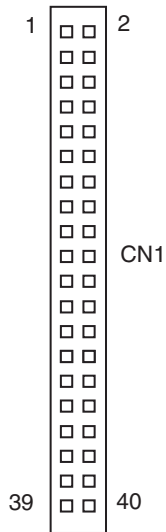

Pin No.	Name	Address	Pin No.	Name	Address
1	External input 0	CIO 0000.00	2	External input 8	CIO 0000.08
3	External input 1	CIO 0000.01	4	External input 9	CIO 0000.09
5	External input 2	CIO 0000.02	6	External input 10	CIO 0000.10
7	External input 3	CIO 0000.03	8	External input 11	CIO 0000.11
9	External input 4	CIO 0000.04	10	External input 12	CIO 0000.12
11	External input 5	CIO 0000.05	12	External input 13	CIO 0000.13
13	External input 6	CIO 0000.06	14	External input 14	CIO 0000.14
15	External input 7	CIO 0000.07	16	External input 15	CIO 0000.15
17	Common for external inputs 0 to 7	---	18	Common for external inputs 8 to 15	
19	External output 0	CIO 0001.00	20	External output 4	CIO 0001.04
21	External output 1	CIO 0001.01	22	External output 5	CIO 0001.05
23	External output 2	CIO 0001.02	24	External output 6	CIO 0001.06
25	External output 3	CIO 0001.03	26	External output 7	CIO 0001.07
27	Common for external outputs 0 to 8		28	Power supply for external outputs 0 to 8	
29	Not used.		30	Not used.	
31	Not used.		32	Not used.	
33	SDA- (RS-422A)		34	RDA- (RS-422A)	
35	SDB+ (RS-422A)		36	RDB+ (RS-422A)	
37	Not used.		38	Not used.	
39	Not used.		40	Not used.	

**FQM1-MM□21 Motion Control Modules**

**General-purpose I/O 26-pin Connector**

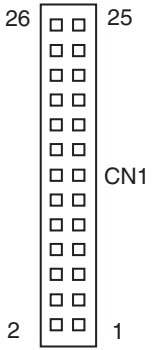

Pin No.	Name	Address	Pin No.	Name	Address
26	Not used.		25	Not used.	
24	External input 0 (interrupt input)	CIO 0000.00	23	External input 6	CIO 0000.06
22	External input 1 (interrupt input)	CIO 0000.01	21	External input 7	CIO 0000.07
20	External input 2 (interrupt input)	CIO 0000.02	19	External input 8	CIO 0000.08
18	External input 3 (interrupt input)	CIO 0000.03	17	External input 9	CIO 0000.09
16	External input 4	CIO 0000.04	15	External input 10	CIO 0000.10
14	External input 5	CIO 0000.05	13	External input 11	CIO 0000.11
12	Common for external inputs 0 to 3		11	Common for external inputs 4 to 11	
10	External output 0	CIO 0001.00	9	External output 4	CIO 0001.04
8	External output 1	CIO 0001.01	7	External output 5	CIO 0001.05
6	External output 2	CIO 0001.02	5	External output 6	CIO 0001.06
4	External output 3	CIO 0001.03	3	External output 7	CIO 0001.07
2	Common for external outputs 0 to 7		1	Power supply for external outputs 0 to 7	

**FQM1-MMP21 Pulse I/O 40-pin Connector**

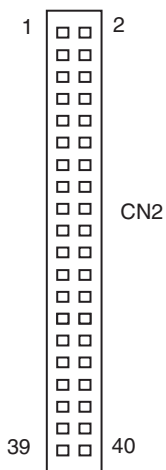

Pin No.	Name		Pin No.	Name	
1	Counter 1	Phase A 24 V	2	Counter 2	Phase A 24 V
3		Phase A LD+	4		Phase A LD+
5		Phase A LD-/0 V	6		Phase A LD-/0 V
7		Phase B 24 V	8		Phase B 24 V
9		Phase B LD+	10		Phase B LD+
11		Phase B LD-/0 V	12		Phase B LD-/0 V
13		Phase Z 24 V	14		Phase Z 24 V
15		Phase Z LD+	16		Phase Z LD+
17		Phase Z LD-/0 V	18		Phase Z LD-/0 V
19		Latch signal 1 input	20		Latch signal 2 input
21	Latch signal common	22	Latch signal common		

Pin No.	Name		Pin No.	Name		
23	Counter 1 SEN output signal for absolute Servo Driver	SEN output	24	Counter 2 SEN output signal for absolute Servo Driver	SEN output	
25		SEN_0 V	26		Power supply for pulse outputs	5-V GND
27		5-V power for SEN output	28			5-V power for pulse outputs
29	Pulse 1	CW+	30	Pulse 2	CW+	
31		CW-	32		CW-	
33		CCW+	34		CCW+	
35		CCW-	36		CCW-	
37		One-shot pulse output 1	38		One-shot pulse output 2	
39		Common for one-shot pulse output	40		24-V power for one-shot pulse output	

FQM1-MMA21 Analog I/O 40-pin Connector

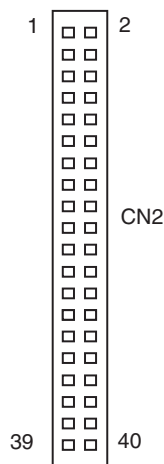

Pin. No.	Name		Pin. No.	Name		
1	Counter 1	Phase A 24 V	2	Counter 2	Not used.	
3		Phase A LD+	4		Phase A LD+	
5		Phase A LD-/0 V	6		Phase A LD-/0 V	
7		Phase B 24 V	8		Not used.	
9		Phase B LD+	10		Phase B LD+	
11		Phase B LD-/0 V	12		Phase B LD-/0 V	
13		Phase Z 24 V	14		Not used.	
15		Phase Z LD+	16		Phase Z LD+	
17		Phase Z LD-/0 V	18		Phase Z LD-/0 V	
19		Latch signal 1 input	20		Latch signal 2 input	
21	Latch signal common	22	Latch signal common			
23	Counter 1 SEN output signal for absolute Servo Driver	SEN output	24	Counter 2 SEN output signal for absolute Servo Driver	SEN output	
25		SEN_0 V	26		---	Not used.
27		5-V power for SEN output	28		---	Not used.
29	---	Not used.	30	---	Not used.	
31	---	Not used.	32	---	Not used.	

Pin. No.	Name		Pin. No.	Name	
33	Analog input	Voltage input (+)	34	Analog input	Current input (See note.)
35		Voltage input (-)	36		(Current input common)
37	Analog output 1	Voltage output (+)	38	Analog output 2	Voltage output (+)
39		Voltage output (-)	40		Voltage output (-)

**Note** Connect the voltage input (+) and the current input when using with a current input between 4 and 20 mA.

### 3-3-2 External Connection Diagrams

The connections with the Servo Drivers, the main type of device connected, are outlined in the following tables.

#### FQM1-MM□21 Motion Control Modules

##### Pulse Outputs

Motion Control Module			W-series Servo Driver	
General-Purpose I/O Connector (26 pin)	Inputs	Positioning Completed Signal	INP1	Positioning completed output
		Origin Proximity Input Signal		
		CCW Limit Input		
		CW Limit Input		
	Outputs	Servo ON	RUN	RUN command input
		Alarm reset	RESET	Alarm reset input
		Error Counter Reset	ECRST	Error Counter Reset Input
Special I/O Connector (40 pin)	Inputs	Phase Z LD+	+Z	Encoder output phase Z
		Phase Z LD-	-Z	Encoder output phase Z
	Outputs	Pulse output CCW	CCW	Forward pulse
		Pulse output CW	CW	Reverse pulse

##### Analog Outputs

Motion Control Module			W-series Servo Driver	
General-purpose I/O Connector (26 pin)	Inputs	Origin Proximity Input Signal		
		CCW Limit Input		
		CW Limit Input		
	Outputs	Servo ON	RUN	Run command input
		Alarm reset	RESET	Alarm reset input
Special I/O Connector (40 pin)	Inputs	Phase A LD+	+A	Encoder output phase A
		Phase A LD-	-A	Encoder output phase A
		Phase B LD+	+B	Encoder output phase B
		Phase B LD-	-B	Encoder output phase B
		Phase Z LD+	+Z	Encoder output phase Z
		Phase Z LD-	-Z	Encoder output phase Z
	Outputs	Analog output 1 (+)	REF	Speed command input
		Analog output 1 (-)	AGND	Speed command input
		Analog output 2 (+)	TREF	Torque command input
		Analog output 2 (-)	AGND	Torque command input



### 3-3-3 Wiring Examples

#### Connecting Pulse Inputs (FQM1-MMP21/MMA21)

Connect the output from an encoder to the connector in the following way, according to the port's counter operation.

Port 1 Pin number	Port 2 Pin number	Signal name	Encoder output		
			Phase Differential Input Mode	Increment/Decrement Pulse Input Mode	Pulse + Direction Input Mode
24 V: 1 (5)	24 V: 2 (6)	Encoder input A	Encoder phase-A input	Increment pulse input	Pulse input
24 V: 7 (11)	24 V: 8 (12)	Encoder input B	Encoder phase-B input	Decrement pulse input	Direction signal input

**Note** The numbers in parentheses are the pin numbers on the negative side.

#### Example

- The wiring for an encoder (24 V) with an open-collector output is shown below. These examples are for encoders with phases A, B, and Z.

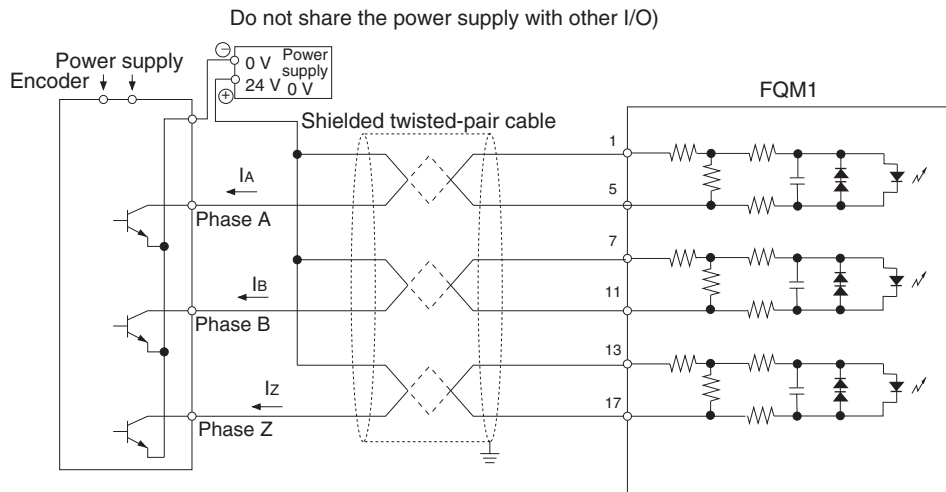
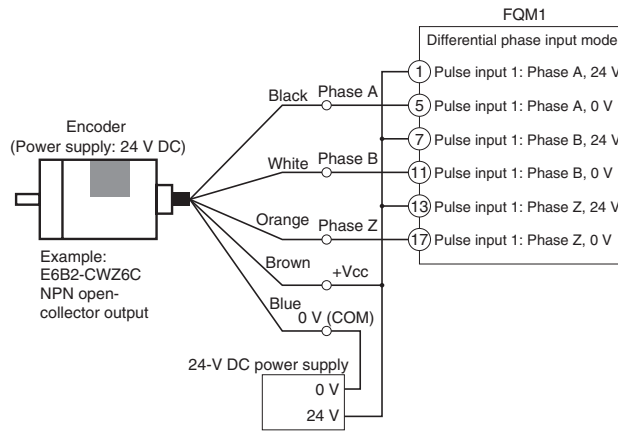

- The wiring for an encoder with a line-driver output (Am26LS31 or equivalent) is shown below.

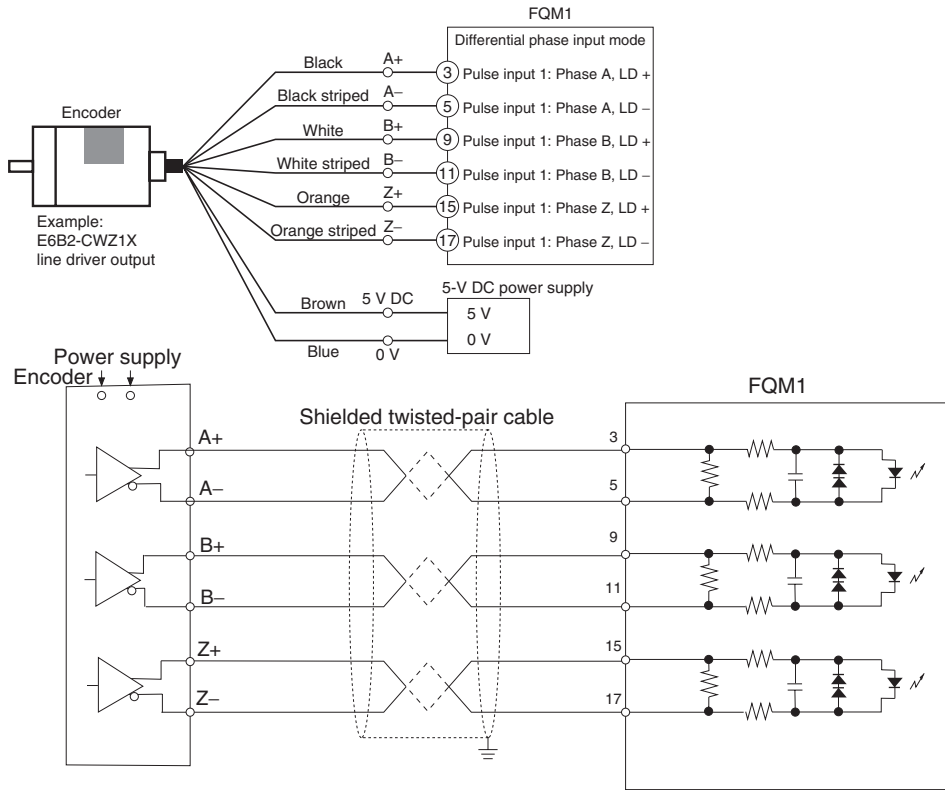

**Connecting a Servo Driver (OMRON's W Series) Compatible with an Absolute Encoder (FQM1-MMP21/MMA21)**

OMRON W-series Servo Driver Compatible with Absolute Encoder

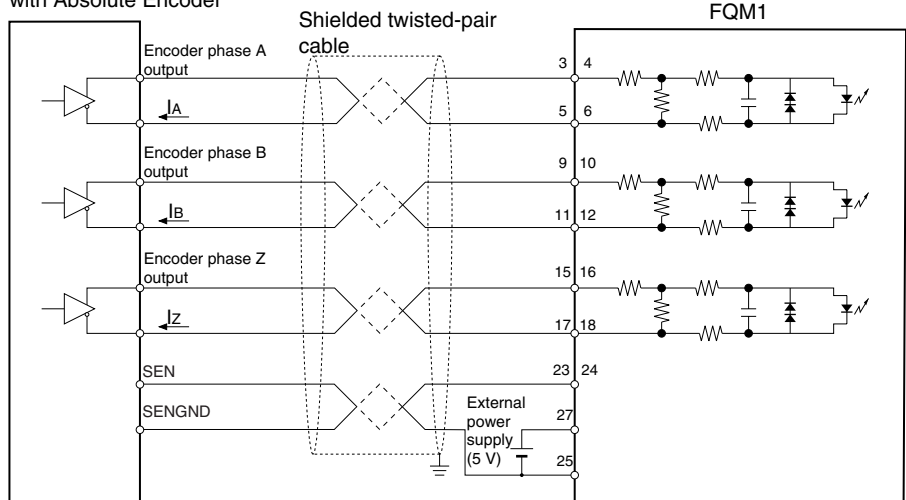

**Connecting Pulse Outputs (FQM1-MMP21)**

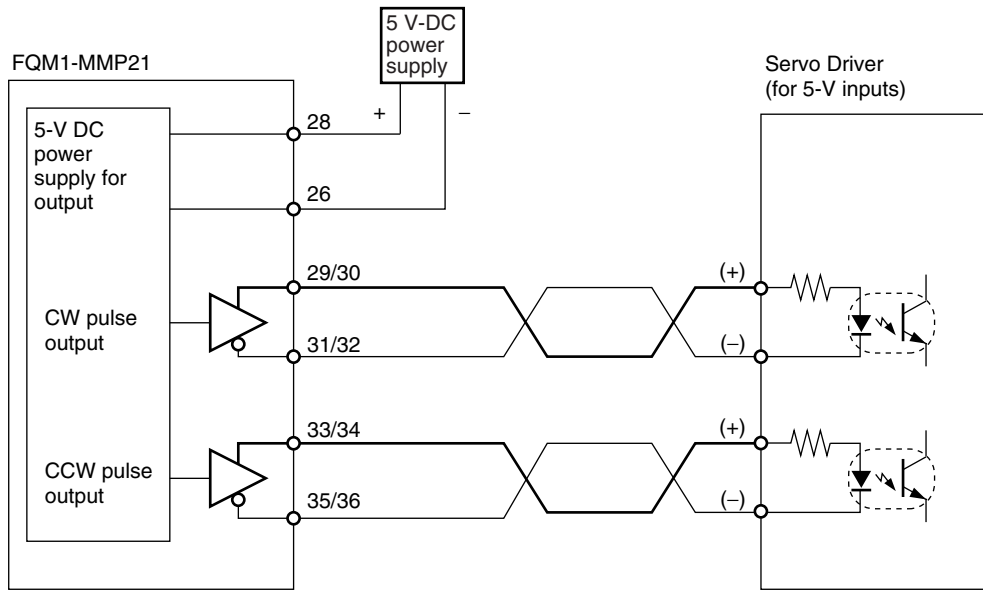

**Example** Connections with a Servo Driver are given below, as an example.

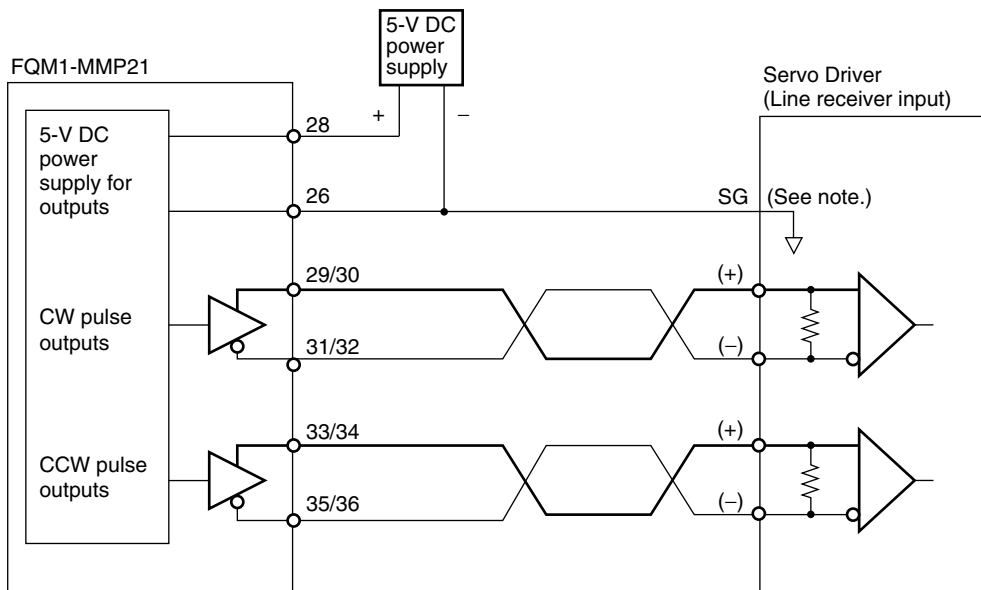

**Note:** When connecting a line receiver, connect the signal ground (SG for the Servo Driver's line receiver input and the GND for the 5-V DC power supply).

**Connecting Analog Outputs (FQM1-MMA21)**

Output signals are connected as shown in the following diagram.

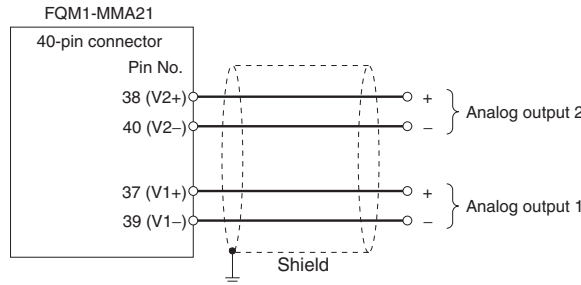

**Connecting Analog Inputs (FQM1-MMA21)**

**Voltage Input**

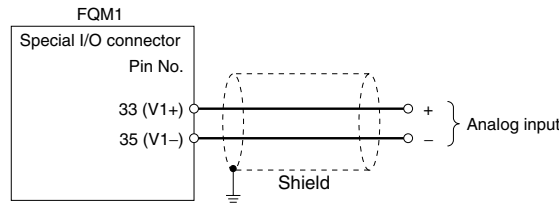

**Current Input**

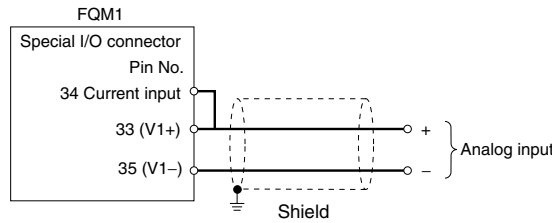

**3-3-4 Wiring Methods**

Either make a cable using the special connector (purchased separately), or connect to a terminal block using an OMRON special cable with a connector.

- Note**
- (1) Do not apply voltages that exceed the maximum switching capacity of output circuits and the input voltage of I/O circuits.
  - (2) Do not mistake positive and negative when wiring power supply, where there are positive and negative terminals.
  - (3) To conform to the EC Low Voltage Directive, use a DC power supply for I/O that has reinforced or double insulation.
  - (4) Check that the connector wiring has been performed correctly before supplying power.
  - (5) Do not pull on cables. Doing so may result in disconnection.
  - (6) Do not bend cables beyond their natural limit. Doing so may result in disconnection.

**Connectors**

**Connecting MIL Connectors**

Connector type	Number of pins	Ordering as a set (OMRON)	DDK Ltd.
Pressure welded	26 pins	XG4M-2630-T	FRC5-A026-3T0S
	40 pins	XG4M-4030-T	FRC5-A040-3T0S

**Applicable Connector-Terminal Block Conversion Units**

Connecting Cable	Connector-Terminal Block Conversion Unit	Number of pins	Size
XW2Z-□□□K	XW2D-40G6	40 pins	Miniature
	XW2B-40G5		Standard
	XW2B-40G4		Standard
XW2Z-□□□J-A28	XW2D-34G6	34 pins	Miniature

**Recommended Wire Size**

The recommended size for cable wires is AWG24 to AWG26 (0.2 to 0.13 mm<sup>2</sup>). Use a cable with an outer diameter of less than 1.61 mm.

**3-4 Wiring Servo Relay Units**

XW2B-80J7-1A Servo Relay Units can be used to connect Motion Control Modules and Servo Drivers.

A Servo Relay Unit simplifies wiring, e.g., from a Motion Control Module to two Servo Drivers, for general-purpose I/O wiring, such as for switches and sensors, and for RS-422A line wiring.

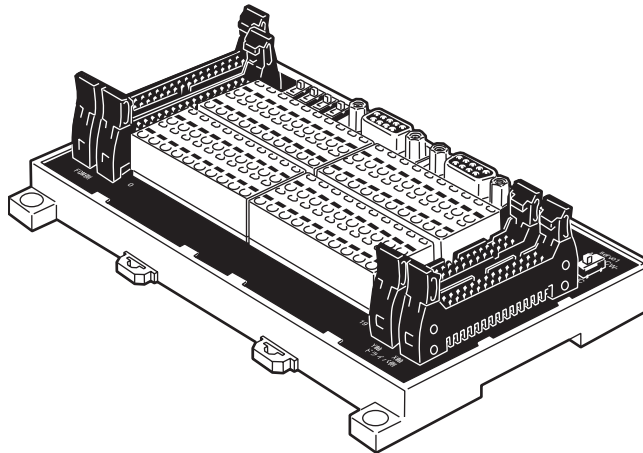

The Servo Relay Unit uses a special cable and simplifies connections from one Motion Control Module to two Servo Drivers, such as the W Series and SMARTSTEP Series.

Servo Relay Units can be mounted to DIN Track or on the panel itself.

**Nomenclature and Functions**

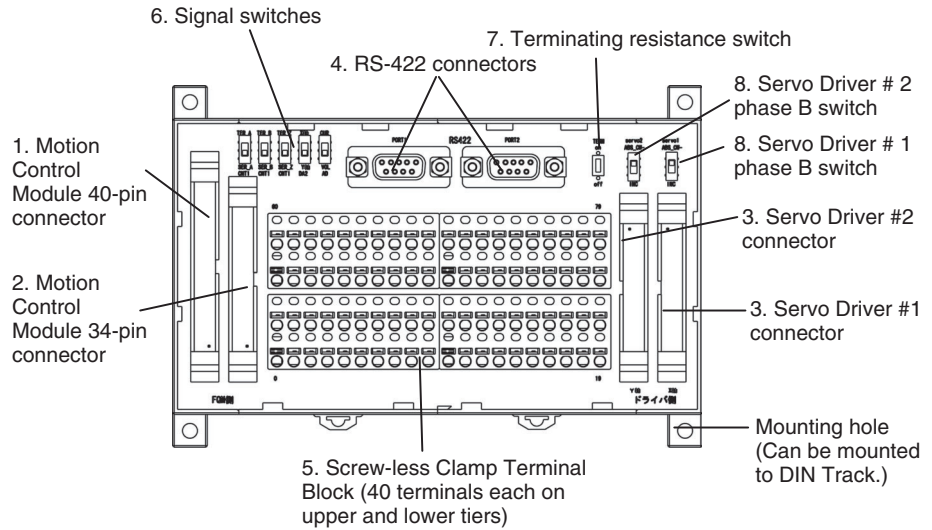

**1,2,3...**

1. Motion Control Module 40-pin Connector  
Connects to the 40-pin connector on the Motion Control Module.
2. Motion Control Module 34-pin Connector  
Connects to the 26-pin connector on the Motion Control Module. The Motion Control Module general-purpose I/O is allocated to the clamp terminal block.
3. Servo Driver Connectors  
Connects to two Servo Drivers.

Motion Control Module	Corresponding connecting cable	Servo Driver cable	Servo Driver
FQM1-MMP21	XW2Z-□□□J-A28 XW2Z-□□□J-A30	XW2Z-□□□J-B9	W-series Servo Driver
		XW2Z-□□□J-B10	SMARTSTEP
FQM1-MMA21	XW2Z-□□□J-A28 XW2Z-□□□J-A31	XW2Z-□□□J-B13	W-series Servo Driver

4. RS-422 Connector

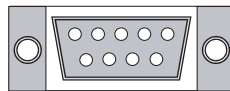

Pin No.	Signal
1	TXD-
2	TXD+
3	---
4	---
5	---
6	RXD-
7	---
8	RXD+
9	---
Case	FG

5. Screw-less, Clamp Terminal Block (80 Terminals)  
The clamp terminal block is used for the Motion Control Module general-purpose I/O and the Servo Driver control signals. It is also used for external device connections, such as analog inputs and latch signal inputs.

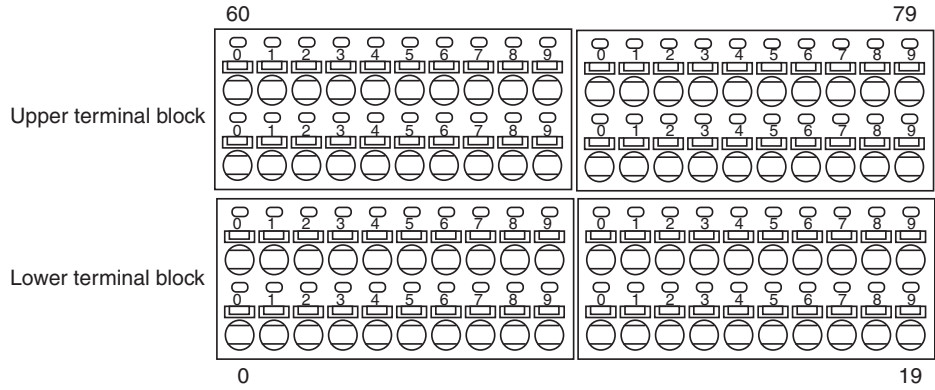

**Upper Terminal Block Pin Arrangement**

No.	60	61	62	63	64	65	66	67	68	69	70	71	72	73	74	75	76	77	78	79
Signal name	5 V (See note 2.)	Latch signal input 1	Latch signal input 2	CNT1 phase A LD + input	CNT1 phase B LD + input	Servo # 1 phase Z LD + output	Voltage input (+) (See note 1.)	Servo #1 ALM	Servo #1 TGO	IN4	IN5	IN6	IN7	---	Servo #1 RUN	Servo #1 RESET	Servo #1 ECRST	Servo #1 MING	TXD+	RXD+
No.	40	41	42	43	44	45	46	47	48	49	50	51	52	53	54	55	56	57	58	59
Signal name	0 V	Latch signal 1 common (0 V)	Latch signal 2 common (0 V)	CNT1 phase A LD -	CNT1 phase B LD -	Servo #1 phase Z LD -	Voltage input (-) (See note 1.)	Servo #1 INP	Common (0 V)	Common (0 V)	Common (0 V)	Common (0 V)	Common (0 V)	---	OUT0	OUT1	OUT2	OUT3	TXD-	RXD-

**Lower Terminal Block Pin Arrangement**

No.	20	21	22	23	24	25	26	27	28	29	30	31	32	33	34	35	36	37	38	39
Signal name	+24 V (See note 3.)	+24 V (See note 4.)	IN0	IN1	IN2	IN3	---	Servo #2 ALM	Servo #2 TGO	IN8	IN9	IN10	IN11	---	Servo #2 RUN	Servo #2 RESET	Servo #2 ECRST	Servo #2 MING	---	FG
No.	0	1	2	3	4	5	6	7	8	9	10	11	12	13	14	15	16	17	18	19
Signal name	0 V	0 V	Common (0 V)	Common (0 V)	Common (0 V)	Common (0 V)	---	Servo #2 INP	Common (0 V)	Common (0 V)	Common (0 V)	Common (0 V)	Common (0 V)	---	OUT4	OUT5	OUT6	OUT7	---	FG

- Note**
- (1) Allocated when connecting an FQM1-MMA21 Analog I/O Motion Control Module.
  - (2) Used as the power supply for FQM1-MMP21 pulse outputs or SEN outputs for Servo Drivers compatible with absolute encoder.
  - (3) IN4 to IN11 and OUT0 to OUT7 are used for the servo control signal power supply.
  - (4) IN0 to IN3 (interrupt inputs) are used for the latch input power supply.

6. Signal Switches

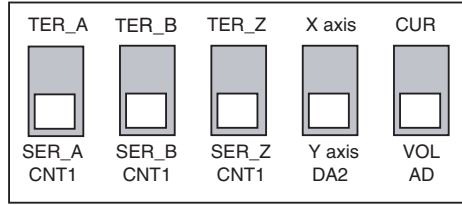

Switch	Setting details	
CNT1 SER_A	SER_A	Connects the Servo #1 phase A to the Motion Control Module's CNT1 phase A.
	TER_A	Connects the external encoder phase A to the Motion Control Module's CNT1 phase A. (See note a.)
CNT1 SER_B	SER_B	Connects the Servo #1 phase B to the Motion Control Module's CNT1 phase B.
	TER_B	Connects the external encoder phase B to the Motion Control Module's CNT1 phase B. (See note a.)
CNT1 SER_Z	SER_Z	Connects the Servo #1 phase Z to the Motion Control Module's CNT1 phase Z.
	TER_Z	Outputs the Servo #1 phase Z output from the terminal.
DA2	Y axis	Connects FQM1-MMA21 analog output 2 to Servo #2 REF.
	X axis	Connects FQM1-MMA21 analog output 2 to Servo #1 TREF.
AD	VOL	Sets analog inputs as voltage inputs.
	CUR	Sets analog inputs as current inputs. (See note b.)

**Note** (a) An external encoder with a line-driver output can be connected.  
 (b) For 4 to 20 mA current inputs, voltage input (+) and current input do not need to be connected.

7. Terminating Resistance Switch

Set this terminating resistance switch to ON when the Servo Relay Unit is at the end of the RS-422A line and the PORT2 terminal is not connected to PORT1 on another Servo Relay Unit.

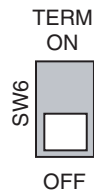

8. Servo Driver Phase B Switches

When the high-speed counter is set to absolute mode CW in the System Setup, inputs are the inverse of the phase from the encoder output phase B from the Servo Driver. The high-speed counter is used in incremental mode for all other System Setup settings.

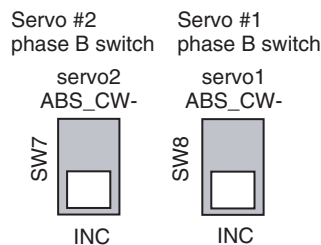



**External Dimensions**

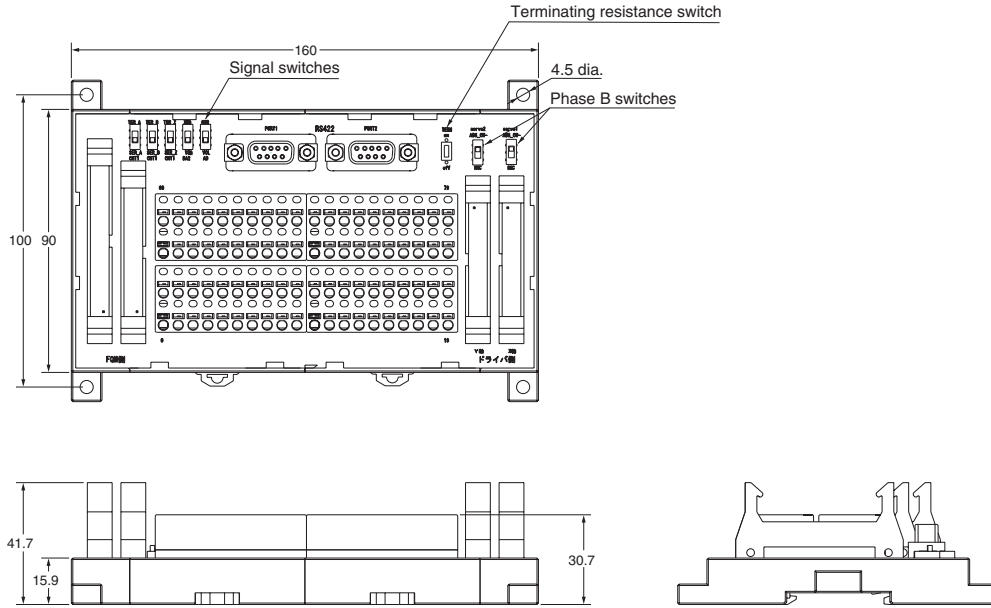

**Wiring Screw-less Clamp Terminal Blocks**

Screw-less clamp terminal blocks use clamps to attach wires, and do not require screws. In addition to control signal wiring to Servo Drivers, clamp terminal blocks can be used to connect sensors and external devices. A ferrule, however, must be connected to the sensor or external device cable when connecting to clamp terminal blocks.

The following table shows the suitable ferrules.

Manufacturer	Model	Applicable wire
Phoenix Contact Inc.	AI-0.5-10	0.5 mm <sup>2</sup> (20AWG)
	AI-0.75-10	0.75 mm <sup>2</sup> (18AWG)
	AI-1.5-10	1.25 mm <sup>2</sup> (16AWG)
Nihon Weidmuller Co. Ltd.	H 0.5/16 D	0.5 mm <sup>2</sup> (20AWG)
	H 0.75/16 D	0.75 mm <sup>2</sup> (18AWG)
	H 1.5/16 D	1.25 mm <sup>2</sup> (16AWG)

**Wiring Method**

- **Inserting Wires**  
Insert the ferrule into the terminal hole.
- **Removing Wires**  
Push and hold the release button on top of the terminal hole with a small flat-blade screwdriver and remove the wire.

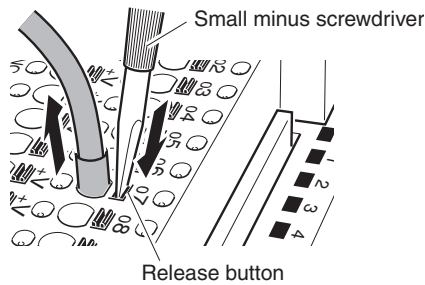

The following screwdriver can be used when removing wires.

**Recommended Screwdriver**

Model	Manufacturer
SZF1	Phoenix Contact Inc.

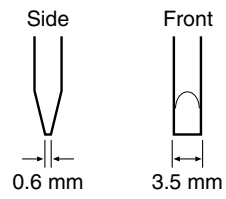

Wiring when Using Servo Relay Units

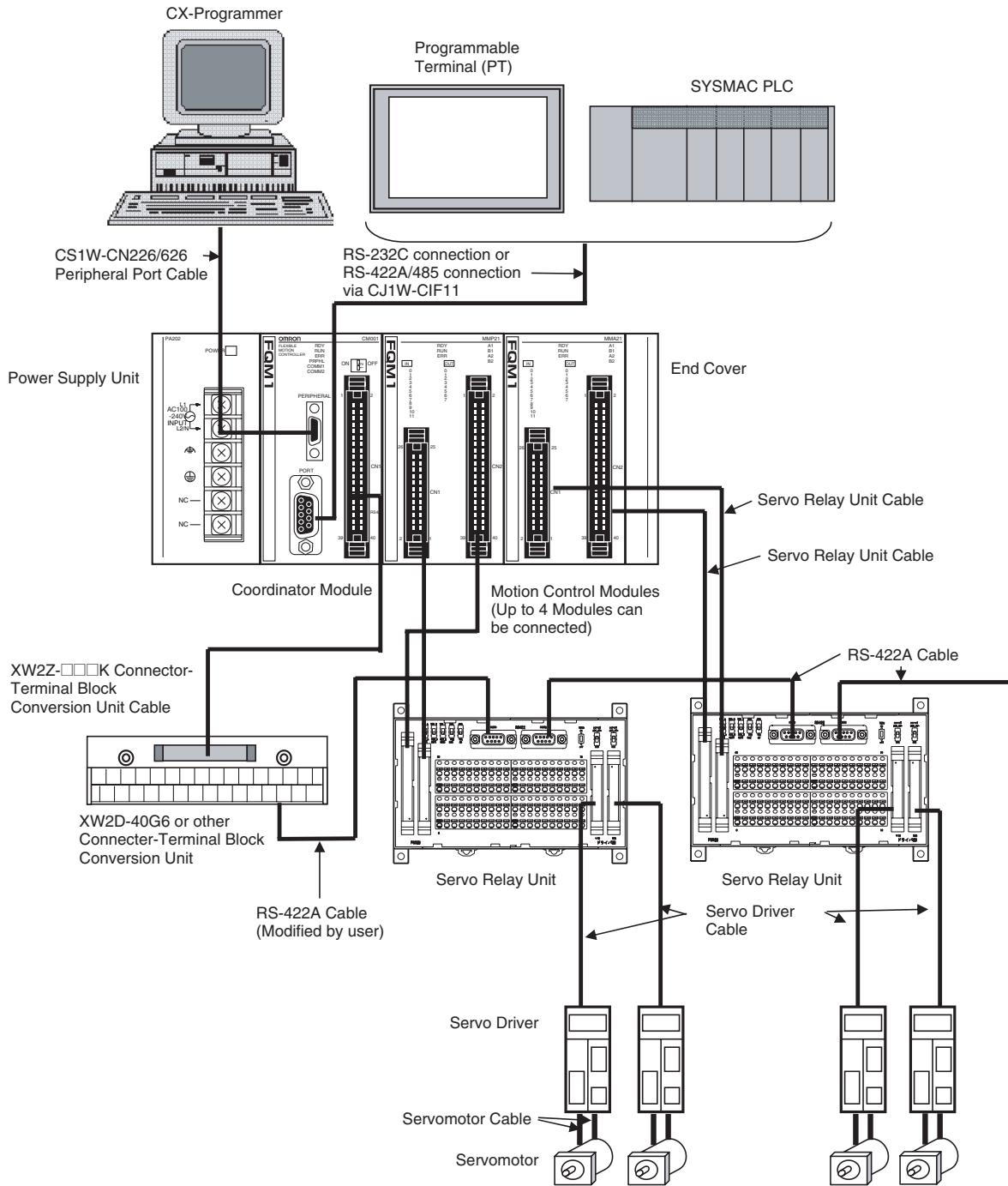

**Example Servo Relay Unit Wiring**

When Servo Relay Units for the FQM1 are used, the I/O power supply is provided from terminals 20-0, 21-1, and 60-40. The only additional wiring required are the connections between the signals, as shown in the following diagram.

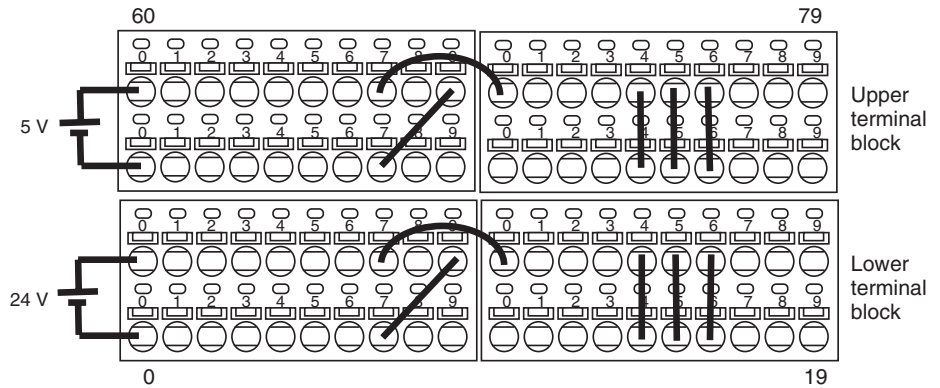

**Upper Terminal Block Arrangement**

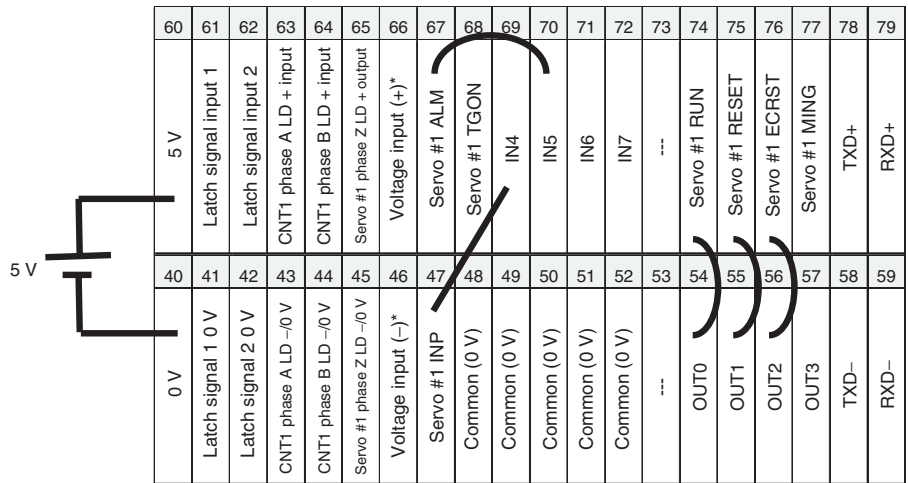

**Lower Terminal Block Arrangement**

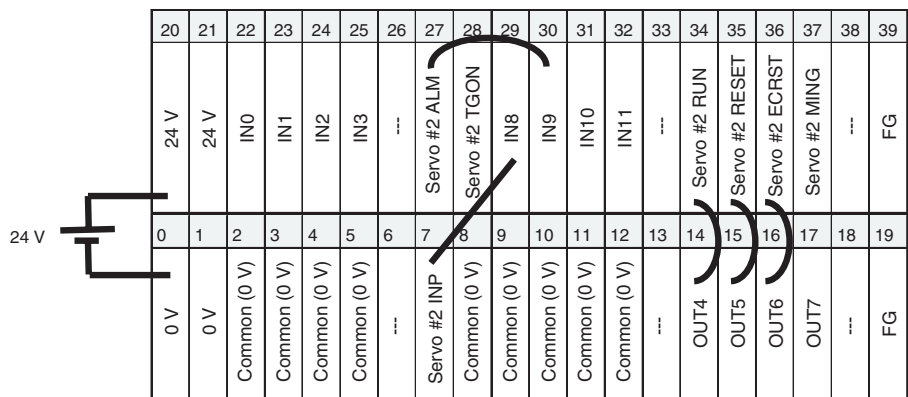

### 3-5 List of FQM1 Connecting Cables

It is recommended that special cables are used when connecting Coordinator and Motion Control Modules to Servo Relay Units.

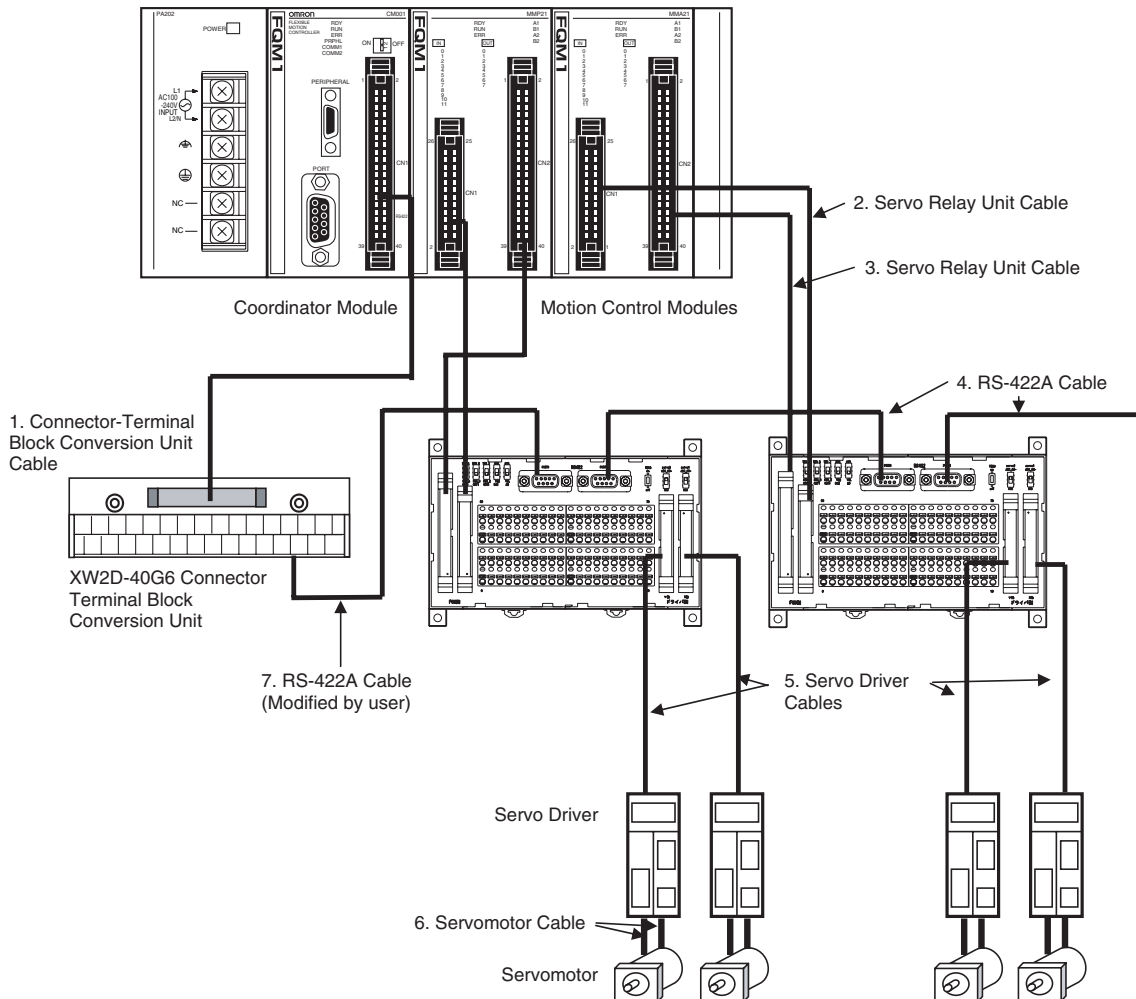

#### Connecting Cable Models

- 1,2,3...** 1. Connector-Terminal Block Conversion Unit Cables (for FQM1-CM001, 40-pin MIL Connector)

Specifications	Model	
Connects FQM1-CM001 and XW2D-40G6 Connector-Terminal Block Conversion Unit.	1 m	XW2Z-100K
	1.5 m	XW2Z-150K
	2 m	XW2Z-200K
	3 m	XW2Z-300K
	5 m	XW2Z-500K

2. Servo Relay Unit Connecting Cables (for FQM1-MMP21/MMA21, 26-pin MIL Connector)

Specifications	Model	
Connects FQM1-MMP21 and Servo Relay Unit.	0.5 m	XW2Z-050J-A28
	1 m	XW2Z-100J-A28

3. Servo Relay Unit Connecting Cables (for FQM1-MMP21/MMA21, 40-pin MIL Connector)

Specifications		Model
Connects FQM1-MMP21 and Servo Relay Unit.	0.5 m	XW2Z-050J-A30
	1 m	XW2Z-100J-A30
Connects FQM1-MMA21 and Servo Relay Unit.	0.5 m	XW2Z-050J-A31
	1 m	XW2Z-100J-A31

4. RS-422A Connecting Cables (with 9-pin D-sub Connector)

Specifications		Model
Connects RS-422A between Servo Relay Units.	1 m	XW2Z-100J-C1
	2 m	XW2Z-200J-C1

5. Servo Driver Connecting Cables (Servo Relay Unit to Servo Driver)

Specifications		Model	
FQM1-MMP21	Connects Servo Relay Unit and W-series Servo Driver.	1 m	XW2Z-100J-B9
		2 m	XW2Z-200J-B9
	Connects Servo Relay Unit and SMARTSTEP.	1 m	XW2Z-100J-B10
		2 m	XW2Z-200J-B10
FQM1-MMA21	Connects Servo Relay Unit and W-series Servo Driver.	1 m	XW2Z-100J-B13
		2 m	XW2Z-200J-B13

6. Servomotor Connecting Cables  
Refer to the catalog for the Servo Driver or Servomotor to be connected.
7. RS-422A Cable, connects Connector-Terminal Block Conversion Unit and Servo Relay Unit.
  - Cut off one end of the RS-422A cable listed above (4.) and attach crimp terminals.

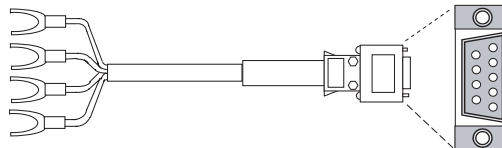

Pin No.	Signal
1	TXD-
2	TXD+
3	---
4	---
5	---
6	RXD-
7	---
8	RXD+
9	---
Case	FG

- Attach the modified cable to the XW2D-40G6 Connector-Terminal Block Conversion Unit.

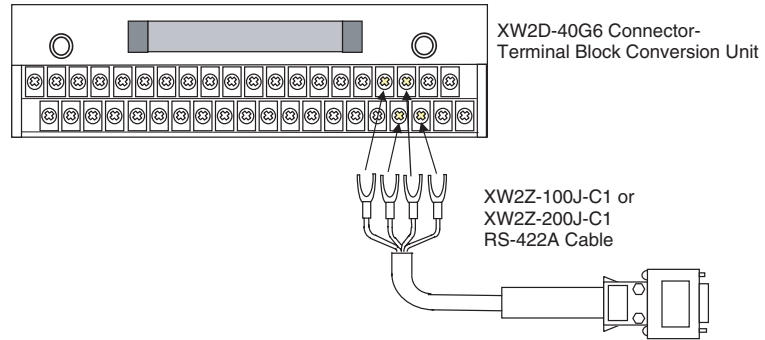

RS-422A Connecting Cable		Connector-Terminal Block Conversion Unit terminal number
No.	Signal	
2	SDB+	A18
1	SDA-	A17
8	RDB+	B18
6	RDA-	B17

### 3-6 Wiring Precautions

#### 3-6-1 Reducing Electrical Noise

##### I/O Signal Wiring

Whenever possible, place I/O signal lines and power lines in separate ducts or raceways both inside and outside of the control panel.

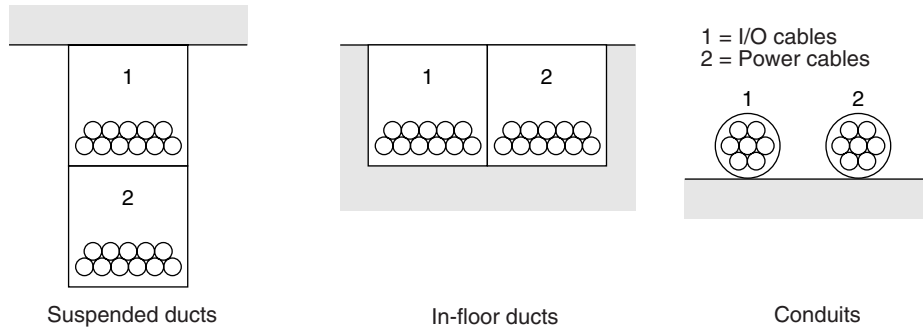

If the I/O wiring and power wiring must be routed in the same duct, use shielded cable and connect the shield to the GR terminal to reduce noise.

**Inductive Loads**

When an inductive load is connected to I/O, connect a surge suppressor or diode in parallel with the load as shown below.

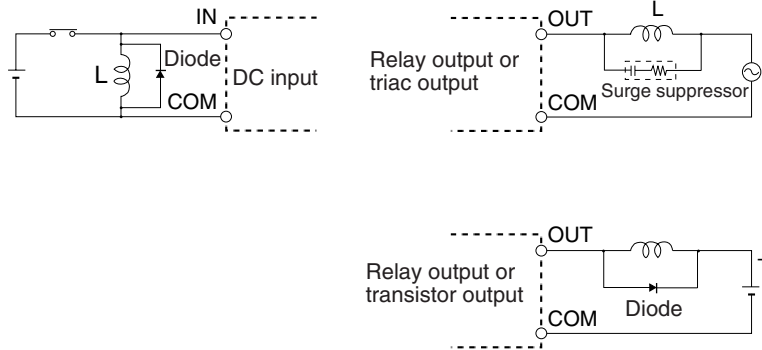

**Note** Use surge suppressors and diodes with the following specifications.

Surge suppressor specifications	Diode specifications
Resistor: 50 Ω Capacitor: 0.47 μF Voltage: 200 V	Breakdown voltage: 3 times load voltage min. Mean rectification current: 1 A

**External Wiring**

Observe the following precautions for I/O wiring, power supply wiring, and power line wiring.

- When multi-conductor signal cable is being used, do not combine I/O wires and other control wires in the same cable.
- If wiring racks are parallel, allow at least 300 mm between the racks.

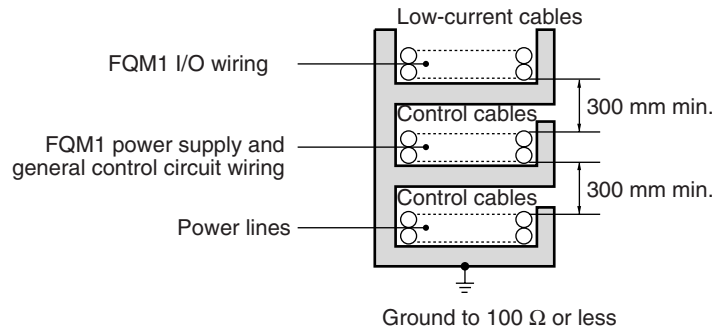

- If the I/O wiring and power cables must be placed in the same duct, they must be shielded from each other using grounded steel sheet metal.

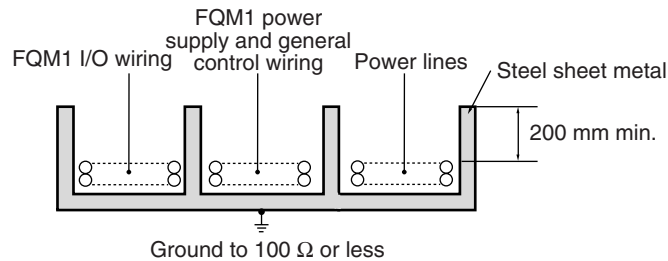



### 3-6-2 Connecting I/O Devices

#### Input Devices

Use the following information for reference when selecting or connecting input devices.

#### DC Inputs

The following types of DC input devices can be connected.

Contact output

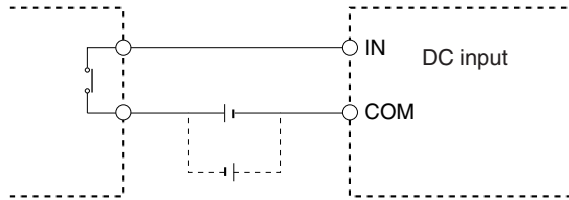

Two-wire DC output

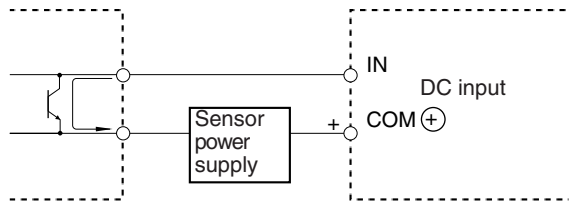

NPN open-collector output

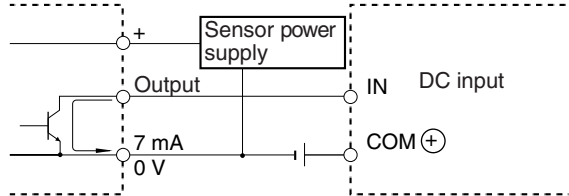

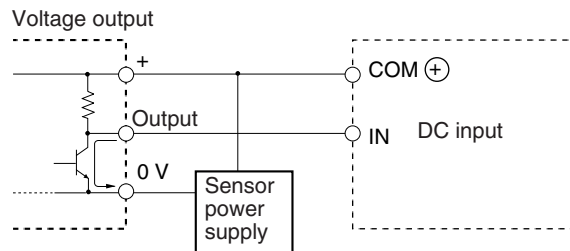
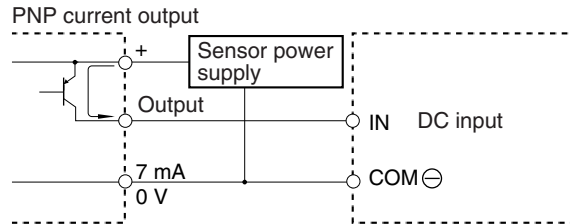
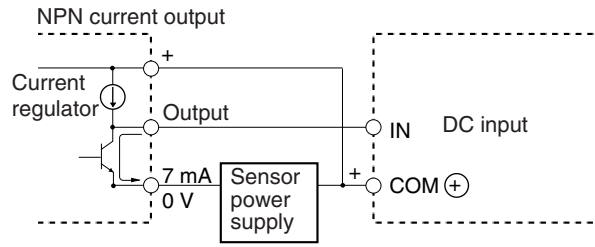

- The circuit below should **NOT** be used for I/O devices having a voltage output.

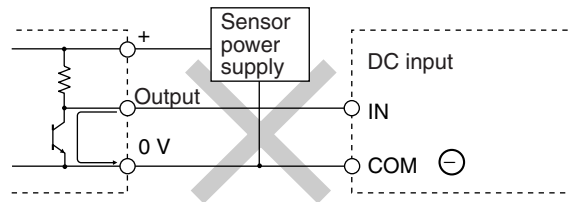

**Precautions when Connecting a Two-wire DC Sensor**

When using a two-wire sensor with a 24-V DC input device, check that the following conditions have been met. Failure to meet these conditions may result in operating errors.

1,2,3...

1. Relation between the FQM1 ON voltage and the sensor residual voltage:  
 $V_{ON} \leq V_{CC} - V_R$
2. Relation between the FQM1 ON current and sensor control output (load current):  
 $I_{OUT} (min) \leq I_{ON} \leq I_{OUT} (max.)$   
 $I_{ON} = (V_{CC} - V_R - 1.5 \text{ [FQM1 internal residual voltage]})/R_{IN}$   
 If  $I_{ON}$  is smaller than  $I_{OUT} (min)$ , connect a bleeder resistor R. The bleeder resistor constant can be calculated as follows:  
 $R \leq (V_{CC} - V_R)/(I_{OUT} (min.) - I_{ON})$   
 $Power W \geq (V_{CC} - V_R)^2/R \times 4 \text{ [allowable margin]}$

- Relation between FQM1 OFF current and sensor leakage current:

$$I_{OFF} \geq I_{leak}$$

Connect a bleeder resistor R if  $I_{leak}$  is greater than  $I_{OFF}$ . Use the following equation to calculate the bleeder resistance constant.

$$R \leq (R_{IN} \times V_{OFF}) / (I_{leak} \times R_{IN} - V_{OFF})$$

$$\text{Power } W \geq (V_{CC} - V_R)^2 / R \times 4 \text{ [allowable margin]}$$

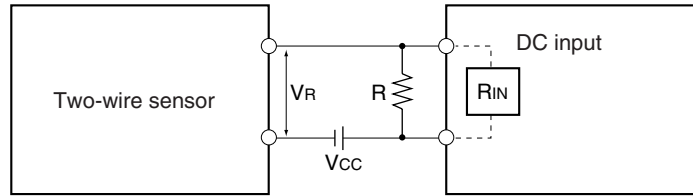

- $V_{CC}$ : Power voltage
- $V_{ON}$ : FQM1 ON voltage
- $V_{OFF}$ : FQM1 OFF voltage
- $I_{ON}$ : FQM1 ON current
- $I_{OFF}$ : FQM1 OFF current
- $R_{IN}$ : FQM1 input impedance
- $V_R$ : Sensor output residual voltage
- $I_{OUT}$ : Sensor control current (load current)
- $I_{leak}$ : Sensor leakage current
- R: Bleeder resistance

- Precautions on Sensor Surge Current

An incorrect input may occur if a sensor is turned ON after the FQM1 has started up to the point where inputs are possible. Determine the time required for sensor operation to stabilize after the sensor is turned ON and take appropriate measures, such as inserting into the program a timer delay after turning ON the sensor.

**Programming Example**

In this example, the sensor's power supply voltage is used as the input to CIO 0000.00 and a 100-ms timer delay (the time required for an OMRON Proximity Sensor to stabilize) is created in the program. After the Completion Flag for the timer turns ON, the sensor input on CIO 0000.01 will cause output bit CIO 0001.00 to turn ON.

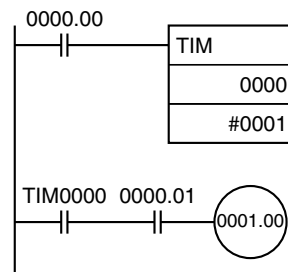

**Output Wiring Precautions**

**Output Short-circuit Protection**

If a load connected to the output terminals is short-circuited, output components and printed circuit boards may be damaged. To guard against this, incorporate a fuse in the external circuit. Use a fuse with a capacity of about twice the rated output.

**Transistor Output Residual Voltage**

A TTL circuit cannot be connected directly to a transistor output because of the transistor's residual voltage. It is necessary to connect a pull-up resistor and a CMOS IC between the two.

**Output Surge Current**

When connecting a transistor or triac output to an output device having a high surge current (such as an incandescent lamp), steps must be taken to avoid damage to the transistor or triac. Use either of the following methods to reduce the surge current.

**Method 1**

Add a resistor that draws about 1/3 of the current consumed by the bulb.

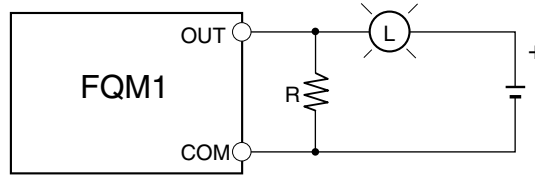

**Method 2**

Add a control resistor as shown in the following diagram.

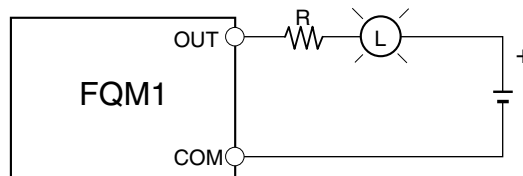

# SECTION 4

## Operation

This section describes the operation of the FQM1.

4-1	Coordinator Module .....	92
4-1-1	Outline .....	92
4-1-2	Coordinator Module Operation.....	93
4-1-3	I/O Refreshing and Peripheral Servicing .....	94
4-1-4	Startup Initialization .....	94
4-2	Motion Control Modules.....	95
4-2-1	Outline .....	95
4-2-2	Description of Each Area .....	95
4-2-3	Motion Control Module Operation.....	96
4-3	Operating Modes.....	99
4-3-1	Operating Modes .....	99
4-3-2	Status and Operations in Each Operating Mode.....	99
4-3-3	Operating Mode Changes and I/O Memory .....	100
4-4	Power OFF Operation .....	100
4-4-1	Power OFF Operation.....	100
4-4-2	Instruction Execution for Power Interruptions .....	102

## 4-1 Coordinator Module

The FQM1 Coordinator Module and each Motion Control Module have separate ladder programming. Each Module independently processes the ladder programming, I/O, and peripheral servicing to achieve high-speed I/O response somewhat like a system of multiple CPU Units.

### 4-1-1 Outline

The Coordinator Module mainly manages FQM1 operation and performs peripheral servicing. It has 24 general-purpose I/O, a peripheral port, RS-232C port, and RS-422 port. The following diagram shows the internal structure of the Coordinator Module.

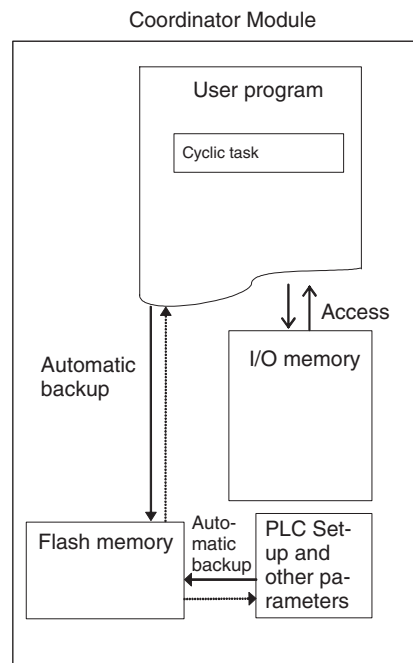

### User Program

The CX-Programmer (see note) is used to create the user programs, which are transferred to the Coordinator Module via the peripheral port. The user programs include a cyclic task, which is executed once per cycle, and interrupt tasks, which are executed at synchronous data refresh. The cyclic task is executed every cycle.

Instructions written in a program are executed in order from the beginning of the program, and these instructions are used to read from and write to I/O memory. Once the cyclic task has been completed, cyclic refreshing with the Motion Control Modules is executed, and then the cyclic task is executed again (cyclic scan method).

**Note** Install the FQM1 Patch Software for CX-Programmer Ver. 5.0. CX-Programmer Ver. 4.0 or earlier cannot be used. Refer to 8-1 *CX-Programmer* for details.

### I/O Memory

I/O memory is the RAM memory area accessed by the user programs. Part of I/O memory area is cleared and part of the memory area is retained when the power is turned OFF and ON again.

I/O memory is also divided into an area that exchanges data with the Motion Control Modules and an area that is used for internal processing.

**System Setup**

The System Setup contains software switches used to make initial settings and other settings. As shown in *Appendix C System Setup, Auxiliary Area Allocations, and Built-in I/O Allocations*, addresses (words and bits) are allocated for settings in the System Setup. The addresses can normally be ignored when making the settings, however, because the settings follow CX-Programmer menus.

**Flash Memory**

When the user writes to the Coordinator Module, the user program, System Setup settings, other parameters, and part of the DM Area are automatically backed up to flash memory.

**4-1-2 Coordinator Module Operation**

The following flowchart shows the operation of the Coordinator Module. Programming is executed before I/O is refreshed and peripherals are serviced. This cycle is executed repeatedly.

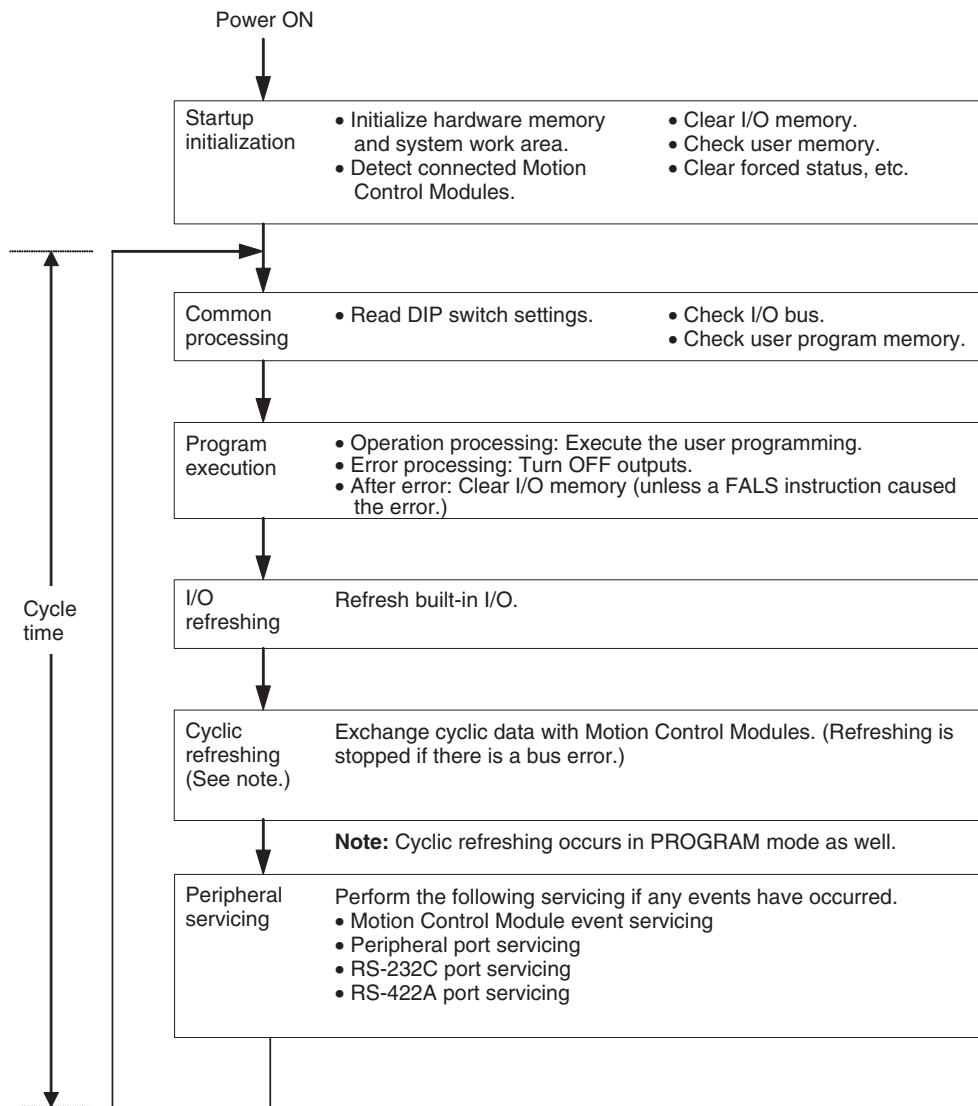

### 4-1-3 I/O Refreshing and Peripheral Servicing

#### I/O Refreshing

I/O refreshing updates general-purpose I/O status. All I/O is refreshed in the same cycle (i.e., time slicing is not used). I/O refreshing is always performed after program execution.

#### Cyclic Refreshing

For cyclic refreshing, data is exchanged every cycle between predetermined areas and the Motion Control Modules.

#### Peripheral Servicing

Peripheral servicing involves servicing non-scheduled events for external devices. This includes both processing for service requests from external devices and service requests to external devices. Most peripheral servicing involves FINS commands.

The time specified in the system is allocated to each type of servicing and executed every cycle. If the servicing is finished before the end of the allocated time, the remaining time is not used and the next servicing is started.

Servicing	Contents
Motion Control Module event servicing	<ul style="list-style-type: none"> <li>• Non-scheduled servicing for FINS commands from Motion Control Modules.</li> <li>• Non-scheduled servicing for FINS commands from the Coordinator Module to the Motion Control Modules.</li> </ul>
Peripheral port servicing	<ul style="list-style-type: none"> <li>• Non-scheduled servicing for FINS or Host Link commands received via the peripheral or RS-232C ports from the CX-Programmer, PTs, or host computers (e.g., requests for program transfer, monitoring, forced-set/reset operations, or online editing).</li> <li>• Non-scheduled servicing from the Coordinator Module transmitted from the peripheral or RS-232C port.</li> </ul>
RS-232C port servicing	
RS-422A port servicing	<ul style="list-style-type: none"> <li>• Non-scheduled servicing to Servo Driver.</li> </ul>

**Note** Servicing for Motion Control Modules, peripheral ports, RS-232C ports, and RS-422A ports is allocated 6.25% of the immediately preceding cycle time by default. If servicing is separated over more than one cycle, delaying completion of the servicing, set the actual amount of time for *Set Time to All Events* (same time for all services) rather than a percentage on the *Timer/Peripheral Service* Tab Page in the System Setup.

### 4-1-4 Startup Initialization

The following initialization is performed once each time the power is turned ON.

- Detecting mounted Modules
- Clearing the non-retained areas of I/O memory
- Clearing forced-set/reset status
- Performing self-diagnosis (user memory check)
- Restoring the user program
- Restoring retained DM Area data



## 4-2 Motion Control Modules

### 4-2-1 Outline

Motion Control Modules each have independent ladder programming, which perform processing independently from other Modules. The following diagram shows the internal structure of Motion Control Modules.

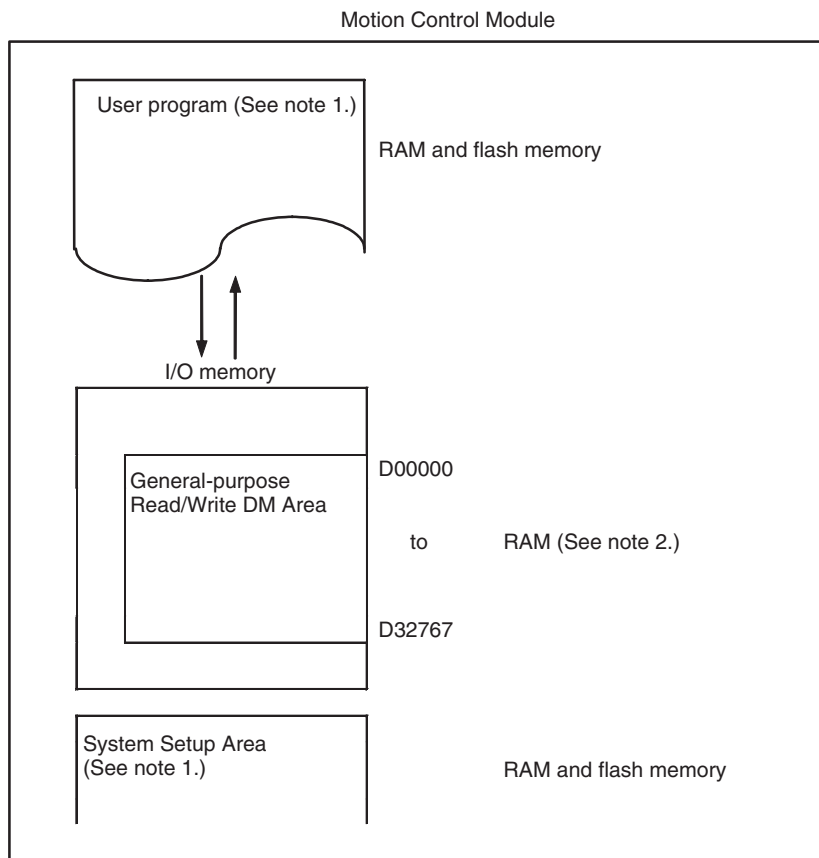

- Note**
- (1) User Memory (UM) Protect  
The following data can be write-protected using settings in the System Setup.
    - User program
    - System Setup Area
 These Areas are stored in RAM and flash memory.
  - (2) Part of the DM Area in the I/O Memory Area is backed up by a super capacitor.

### 4-2-2 Description of Each Area

#### User Program Area

The CX-Programmer (see note) is used to create the Motion Control Module ladder programs and set the System Setup. Programs and settings are transferred to each Motion Control Module through the peripheral port on the Coordinator Module.

The user program is written using ladder diagram programming and executed using a cyclic scan method.

Broadly speaking, the user program consists of a cyclic task and interrupt tasks, which are executed for interrupts. The cyclic task is executed every cycle. The user program is stored in RAM and flash memory. Data is not lost, therefore, even if the super capacitor backup time is exceeded.

**I/O Memory**

I/O memory is the area accessed by the user program and the CX-Programmer. Part of I/O Memory Area is cleared and part of it is retained when the power is turned OFF and ON again.

I/O memory is also divided into an area that exchanges data with other Motion Control Modules and an area that is used for internal processing.

**System Setup**

The System Setup contains software switches used to make initial settings and other settings for the Motion Control Module. Addresses are allocated for the settings in the System Setup, but these addresses can normally be ignored when making the settings, because the settings follow CX-Programmer menus.

The System Setup is stored in RAM and flash memory, so the data is not lost even if the super capacitor backup time is exceeded.

**Read/Write DM Area (D00000 to D32767)**

The Read/Write DM Area can be accessed from the user program.

D00000 to D29999 is cleared when the power is turned OFF and ON again. D30000 to D32767 is retained for a set period by the super capacitor. The data is lost when the super capacitor backup time has been exceeded.

**4-2-3 Motion Control Module Operation**

Operation between the Coordinator Module and the Motion Control Modules can be set to synchronous (“Sync”) or asynchronous (“Async”) modes using a setting in the System Setup of the Coordinator Module.

**System Setup Using CX-Programmer**

Tab page	Item	Settings
Module Settings	Synchronization between Modules	<ul style="list-style-type: none"> <li>• Sync Mode</li> <li>• ASync Mode</li> </ul>

**ASync Mode Operation**

In ASync Mode, scan processing by the Motion Control Modules is not synchronized with the Coordinator Module. Motion Control Module built-in I/O refreshing is executed within the scan cycle in the Motion Control Module. I/O refreshing with the Coordinator Module is determined by the Coordinator Module and is executed asynchronously to the Motion Control Module scan processing.

Synchronous Data Link Bit Area refreshing is not executed in ASync Mode.

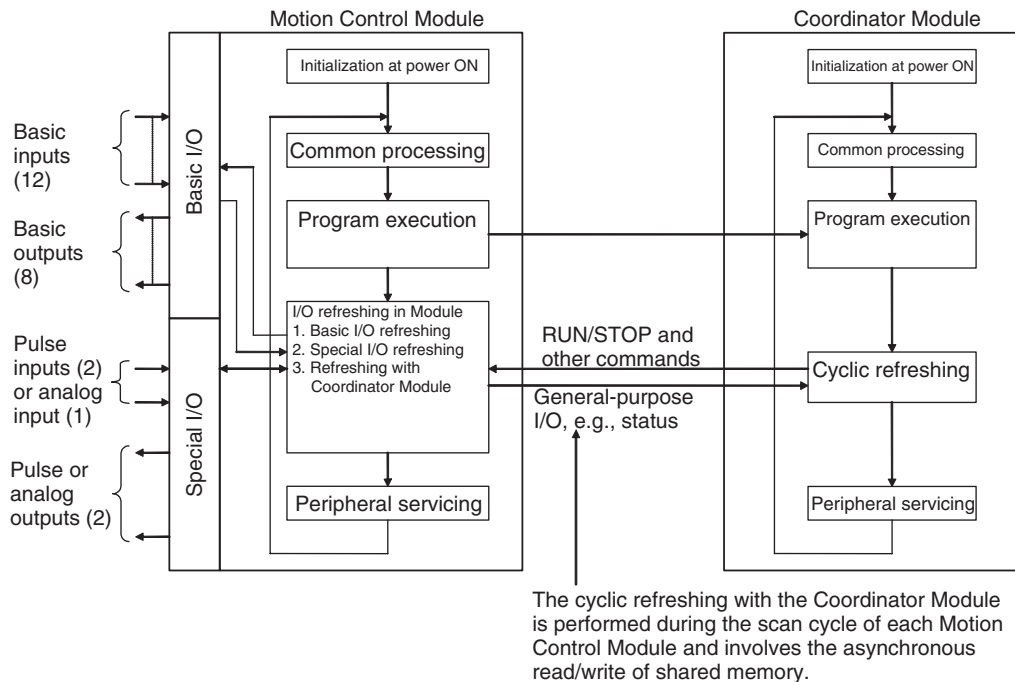

**Sync Mode Operation**

In Sync Mode, the Motion Control Module's cyclic scan is synced with the Coordinator Module's cyclic scan or the sync cycle time set in the System Setup. The program in each Motion Control Module is thus executed at the same time.

When operation is synchronized to the Coordinator Module cycle scan, the start of program execution in every cycle is the same for all Modules. When operation is synchronized to the sync cycle time, the start of program execution in every cycle is the same for all Motion Control Modules.

Motion Control Modules send all synchronous data link bits to the Coordinator Module and all other Motion Control Modules each Coordinator Module cyclic scan or at the specified sync cycle time. (See note 1.)

Each Module can access the synchronous data link bits from all other Modules. (Refer to 5-4 Synchronous Data Refresh for details.)

- Note**
- (1) This depends on the sync cycle time set in the System Setup of the Coordinator Module (0.1 to 10.0 ms, 0.1-ms increments).
  - (2) High-speed counter inputs, pulse outputs, or any other data can be set for each Module.

**Caution** When the Coordinator Module changes from PROGRAM mode to RUN or MONITOR modes, the Motion Control Modules will switch to RUN or MONITOR mode one cycle later. Similarly, when the Coordinator Module switches from RUN or MONITOR modes to PROGRAM mode, the Motion Control Modules will switch one cycle later. The operating modes for all Motion Control Modules will switch in the same cycle.

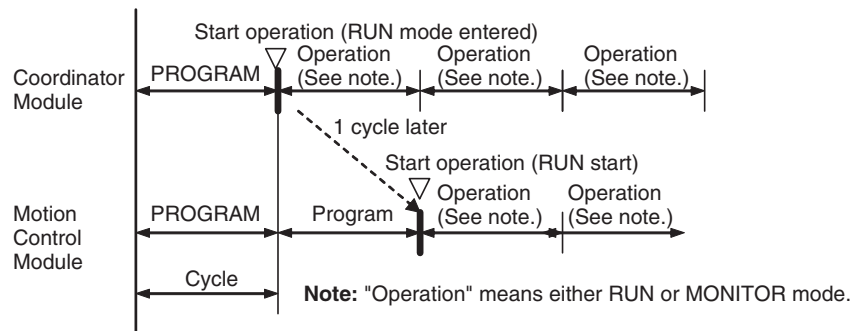

**Initialization at At power ON**

Internal Module initialization (determining the operating mode, initializing user memory, clearing specified memory areas, checking for memory corruption, reading the System Setup, etc.) is performed and the bus that exchanges data with the Coordinator Module is initialized.

**Common Processing**

Common processing, which does not depend on special I/O, is performed.

**Program Execution**

The Motion Control Module's ladder program is executed. Basic I/O is refreshed whenever the IORF instruction is executed. Special I/O can also be refreshed for Modules with analog I/O.

**Cycle Time Calculation**

The execution time for one cycle is monitored. If a constant cycle time is set, processing is performed to make the cycle time constant. (Refer to 5-6-1 *Constant Cycle Time Function* for information on constant cycle time processing.)

**Motion Control Module Built-in I/O Refreshing**

The following 3 types of built-in I/O refreshing are performed by Motion Control Modules.

1,2,3...

1. Basic I/O Refreshing  
Output bits to output contacts, inputs contacts to input bits
2. Special I/O Refreshing  
Pulse inputs, pulse outputs, analog inputs, analog outputs, etc.
3. Coordinator Module Refreshing  
Data exchange with Coordinator Module

**Note**

- (1) Special I/O refreshing refreshes high-speed counter present values and other special I/O.
- (2) Motion Control Module built-in I/O refreshing is also executed in PROGRAM mode and during fatal errors (including FALS instructions) (input refresh only).
- (3) Coordinator Module cyclic refreshing (allocated data exchange) is executed at the same time as the Coordinator Module scan processing. This refreshing exchanges data between the Coordinator Module and the Motion Control Modules, so it is asynchronous with the Motion Control Module's cyclic refreshing. Coordinator Module cyclic refreshing is also executed in PROGRAM mode and during fatal errors (including FALS instructions).

**Peripheral Servicing**

Event servicing requests from the Coordinator Module are serviced.

## 4-3 Operating Modes

### 4-3-1 Operating Modes

Coordinator and Motion Control Modules have three operating modes that control the user program.

#### **PROGRAM**

Programs are not executed and preparations, such as initializing the System Setup and other settings, transferring programs, checking programs, force-setting, force-resetting, and checking wiring can be executed prior to program execution. Motion Control Module built-in I/O refreshing and Coordinator Module cyclic refreshing are, however, executed in this mode.

#### **MONITOR**

Programs are executed, but some operations, such as online editing and changing present values in I/O memory, are enabled for trial operation and other adjustments.

#### **RUN**

Programs are executed but some operations, such as online editing and changing the present values in I/O memory using CX-Programmer, cannot be performed. The CX-Programmer can monitor the program execution status (program and I/O memory monitoring). The main system operation is performed in RUN mode.

- Note**
- (1) The operating mode of Motion Control Modules cannot be changed independently in Sync Mode. Always change the operating mode of the Coordinator Module in Sync Mode.
  - (2) To debug Motion Control Module programs, change the Coordinator Module to ASync Mode under the System Setup and change the operating mode for that Motion Control Module.

### 4-3-2 Status and Operations in Each Operating Mode

PROGRAM, RUN, and MONITOR are the three FQM1 operating modes. The following tables list status and operations for each mode.

Mode	Program execution (See note.)	I/O refresh	External outputs	I/O Memory		CX-Programmer operations											
				Cleared areas	Retained areas	I/O Memory monitoring	Program monitoring	Program transfers		Program check	System Setup changes	Program changes	Force-set/reset	Changing timer/counter SV	Changing timer/counter PV	Changing I/O Memory PV	
								FQM1 to computer	Computer to FQM1								
PROGRAM	Stopped	Executed	OFF	Clear	Retained	OK	OK	OK	OK	OK	OK	OK	OK	OK	OK	OK	OK
RUN	Performed	Executed	Controlled by program	Controlled by program		OK	OK	OK	×	×	×	×	×	×	×	×	×
MONITOR	Performed	Executed	Controlled by program	Controlled by program		OK	OK	OK	×	×	×	OK	OK	OK	OK	OK	OK

**Note** The following table shows the relationship of operating modes to tasks.

Mode	Cyclic task status	Interrupt task status
PROGRAM	Disabled	Stopped
RUN	Enabled	Executed if interrupt condition is met.
MONITOR		

### 4-3-3 Operating Mode Changes and I/O Memory

Mode Changes	Cleared areas	Retained areas
		<ul style="list-style-type: none"> <li>• I/O bits</li> <li>• Data Link bits</li> <li>• Work bits</li> <li>• Timer PV</li> </ul>
RUN or MONITOR to PROGRAM	Cleared (See note 1.)	Retained
PROGRAM to RUN or MONITOR	Cleared (See note 1.)	Retained
RUN to MONITOR or MONITOR to RUN	Retained (See note 2.)	Retained

- Note**
- (1) The cycle time will increase by approximately 10 ms when the operating mode is changed from MONITOR to RUN mode. This will not cause an error for exceeding the maximum cycle time limit.
  - (2) In Sync Mode, the Motion Control Module operating mode will change one cycle after the Coordinator Module operating mode has changed.

## 4-4 Power OFF Operation

### 4-4-1 Power OFF Operation

The following processing is performed if FQM1 power is interrupted during operation. The following power OFF processing will be performed if the power supply falls below 85% of the minimum rated voltage while in RUN or MONITOR mode.

- 1,2,3...**
1. The Motion Control Modules and Coordinator Module will stop.
  2. All outputs from all Modules will be turned OFF.

85% of the rated voltage (AC power):

85 V AC for 100 V

170 V AC for 200 V

85 V AC for 100 to 240 V (wide range)

The following processing will be performed if power drops only momentarily (momentary power interruption).

- 1,2,3...**
1. The system will continue to run unconditionally if the momentary power interruption lasts less than 10 ms, i.e., the time it takes the minimum rated voltage at 85% or less to return to 85% or higher is less than 10 ms.
  2. A momentary power interruption that lasts more than 10 ms but less than 25 ms is difficult to determine and a power interruption may or may not be detected.
  3. The system will stop unconditionally if the momentary power interruption lasts more than 25 ms.

It thus requires between 10 and 25 ms to detect a power interruption. This time can be increased by setting the User-set Power OFF Detection Time (0 to 10 ms) in the System Setup.

- Note** The User-set Power OFF Detection Time appears in the System Setup simply as the "Power OFF Detection Time."

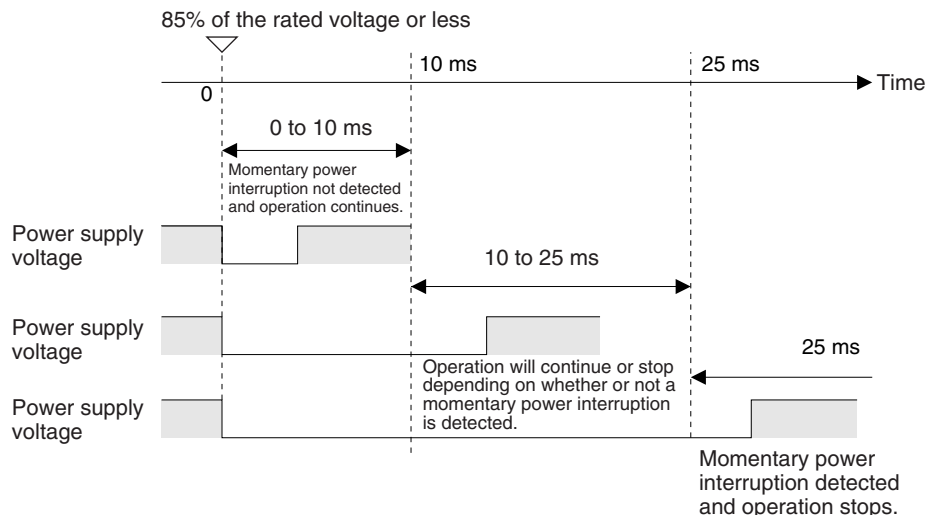

**Note** The above timing chart shows an example when the User-set Power OFF Detection Time is set to 0 ms.

The following timing chart shows the Coordinator Module power OFF operation in more detail.

**Power OFF Timing Chart**

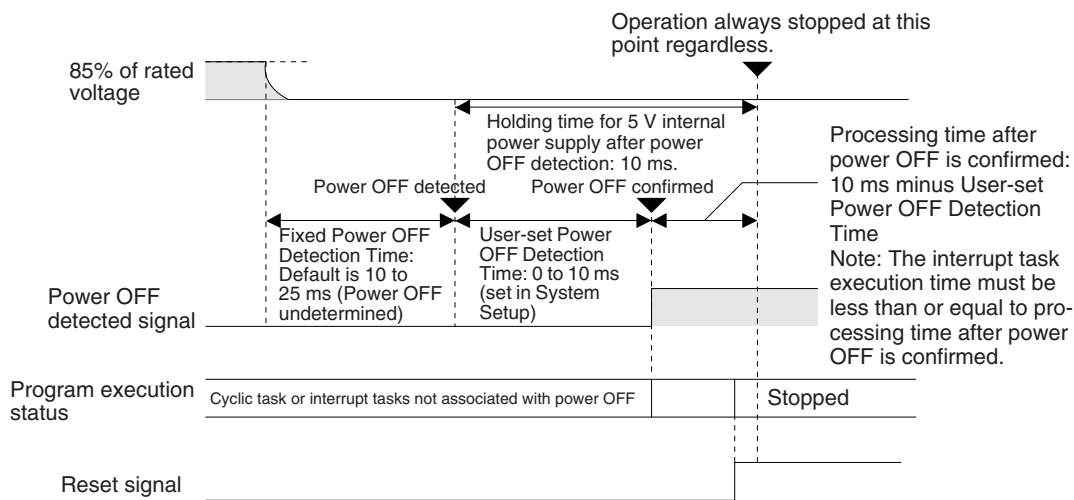

**Fixed Power OFF Detection Time**

The time it takes to detect power OFF after the power supply falls below 85% of the minimum rated voltage.

**User-set Power OFF Detection Time**

The time after power OFF is detected until it is confirmed. This can be set in the System Setup within a range from 0 to 10 ms (default: 0 ms).

If an unstable power supply is causing power interruptions, set a longer User-set Power OFF Detection Time (10 ms max.) in the System Setup.

**Power Holding Time**

The maximum amount of time (fixed at 10 ms) that 5 V will be held internally after power interruption is detected.

**Description of Operation**

Power OFF will be detected if the 100 to 240 V AC power supply stays below 85% of the minimum rated voltage for the Fixed Power OFF Detection Time (variable between 10 to 25 ms.)

If the User-set Power OFF Detection Time is set (0 to 10 ms) in the System Setup, the reset signal will turn ON and the Module will be reset immediately after the User-set Power OFF Detection Time expires.

**4-4-2 Instruction Execution for Power Interruptions**

If power is interrupted and the interruption is confirmed when the Coordinator Module or Motion Control Module is operating in RUN or MONITOR mode, the instruction currently being executed will be completed and then the Module will be reset.



# SECTION 5

## Module Functions and Data Exchange

This section describes the functions common to both the Coordinator Module and Motion Control Modules and the methods to transfer data between the Coordinator Module and Motion Control Modules.

5-1	Synchronous Operation between Modules . . . . .	104
5-2	Data Exchange between Modules . . . . .	105
5-3	Cyclic Refresh . . . . .	106
5-3-1	Outline . . . . .	106
5-3-2	Applications . . . . .	106
5-3-3	Cyclic Refresh Area Details . . . . .	107
5-3-4	Cyclic Refresh Area Allocations . . . . .	108
5-4	Synchronous Data Refresh . . . . .	109
5-4-1	Outline . . . . .	109
5-4-2	Applications . . . . .	109
5-4-3	Synchronous Data Link Bit Area . . . . .	110
5-4-4	Settings . . . . .	111
5-5	DM Data Transfer . . . . .	112
5-5-1	Outline . . . . .	112
5-5-2	Settings Details . . . . .	113
5-5-3	Executing DM Data Transfer . . . . .	113
5-6	Cycle Time Settings . . . . .	114
5-6-1	Constant Cycle Time Function . . . . .	114
5-6-2	Watch Cycle Time Function . . . . .	116
5-6-3	Cycle Time Monitoring Function . . . . .	116
5-6-4	Clearing Constant Cycle Time Exceeded Errors . . . . .	117
5-7	Operation Settings at Startup and Maintenance Functions . . . . .	118
5-7-1	Specifying the Startup Mode . . . . .	118
5-7-2	Program Protection . . . . .	118
5-7-3	Flash Memory . . . . .	119
5-8	Diagnostic Functions . . . . .	120
5-8-1	Error Log . . . . .	120
5-8-2	Failure Alarm Functions . . . . .	121

## 5-1 Synchronous Operation between Modules

### Sync and ASync Modes

#### **Sync Mode**

The Coordinator Module and Motion Control Modules are normally set to operate using the same cycle time, i.e., synchronously. Synchronous operation is the default setting in the System Setup. With this setting, all Motion Control Modules synchronize operation with the Coordinator Module cycle time. This allows synchronous control of up to 8 axes.

System Setup	Default	Settings
Module Settings Tab Page	Sync Mode	Use in Sync Mode (default).
Synchronization between Modules	Sync Cycle Time = 0 ms Coordinator Module cycle time	To operate only the Motion Control Modules with high-speed synchronous operation, set a value for the Coordinator Module sync cycle time.

#### **ASync Mode**

The Motion Control Modules can be operated at high-speed in ASync Mode. Some delays in peripheral servicing may occur, but ASync Mode is useful for increasing the speed of overall system operation.

System Setup	Default	Settings
Module Settings Tab Page	Sync Mode	Set to ASync Mode.
Synchronization between Modules		

## 5-2 Data Exchange between Modules

The three methods for data exchange between Coordinator and Motion Control Modules are outlined in the following table. These methods can be used simultaneously.

Method	Outline	Description
1. Cyclic refresh	Exchanges data each Coordinator Module cycle.	A Cyclic Refresh Area is allocated for each Motion Control Module in the Coordinator Module.
2. Synchronous data refresh	Broadcasts data at a specified sync cycle.	Specified synchronous data is broadcast from each Motion Control Module and the Coordinator Module. All other Modules receive and share the data in the Synchronous Data Link Bit Area.
3. DM data transfer	Transfers large volumes of data between a specified Motion Control Module and the Coordinator Module when required.	Data is transferred in the specified direction between the specified DM Area words of a specified Motion Control Module and the specified DM Area words of the Coordinator Module when the DM Write Request Bit (A530.00) or DM Read Request Bit (A530.01) in the Auxiliary Area of the Coordinator Module is turned ON.

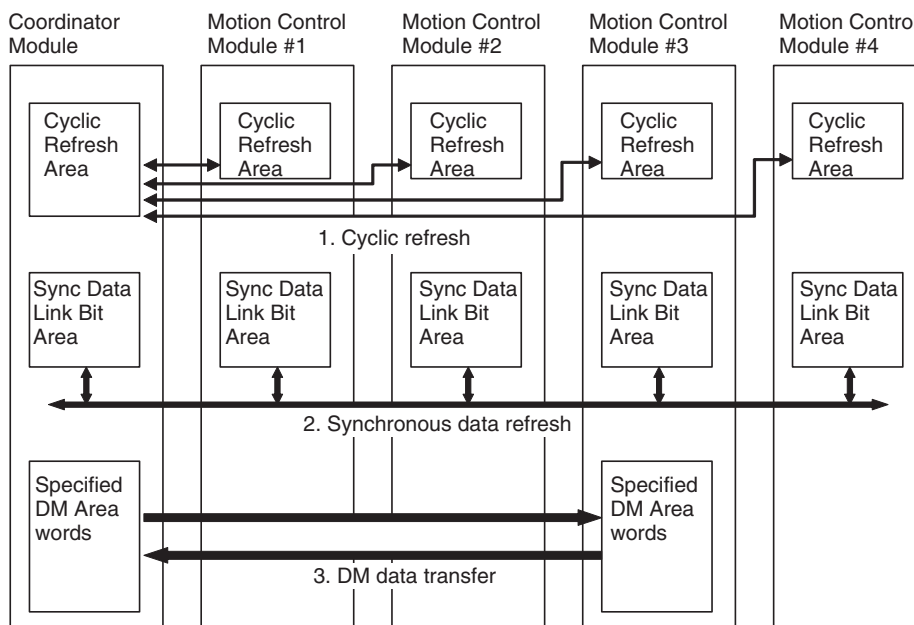

## 5-3 Cyclic Refresh

### 5-3-1 Outline

Status information, general-purpose I/O, and other information for each Motion Control Module in the Cyclic Refresh Area of the Coordinator Module are refreshed every Coordinator Module cycle (asynchronous to the Motion Control Module cycles).

As shown in the following diagram, 10 words per Motion Control Module (5 output words and 5 input words) are allocated according to the Motion Control Module slot number (#1 to #4 in the following diagram) in the Cyclic Refresh Area of the Coordinator Module (CIO 0100 to CIO 0139).

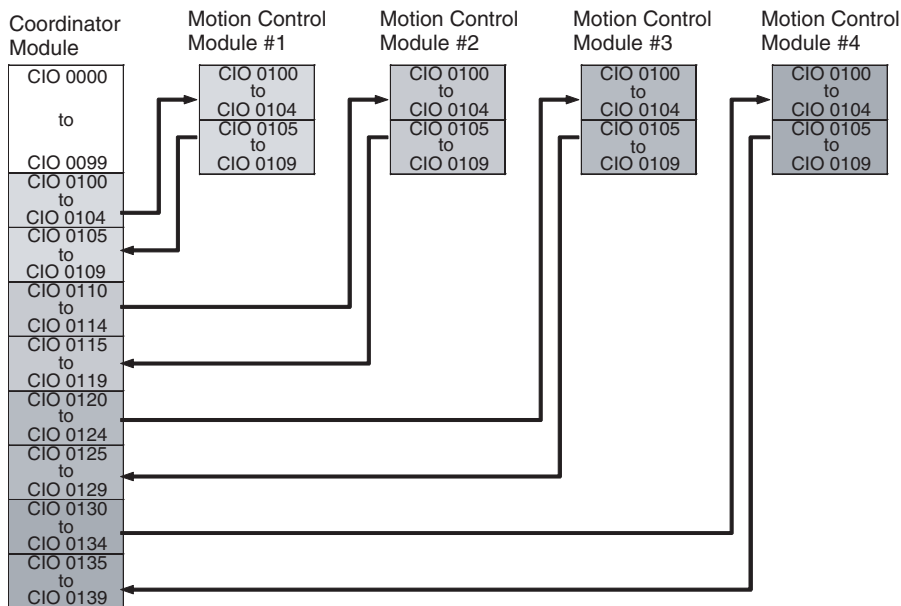

**Note** Cyclic refreshing between the Coordinator Module and Motion Control Modules is asynchronous. Information may take up to 2 cycles to be received.

### 5-3-2 Applications

In addition to the Synchronous Data Link Bit Area, normal data exchange between the Coordinator Module and Motion Control Modules is possible using the Cyclic Refresh Area.

Information for which high-speed data exchange between Modules is not required can be allocated anywhere, and a ladder program written for the Coordinator Module and Motion Control Modules to access these areas during operation can be created.

### 5-3-3 Cyclic Refresh Area Details

#### Coordinator Module Cyclic Refresh Area

CIO 0100 to CIO 0109 in each Motion Control Module is allocated to ten words between CIO 0100 to CIO 0139 in the Coordinator Module according to the slot number for the Motion Control Module.

CM: Coordinator Module  
MM: Motion Control Module

Word address	Bits	Details	
CIO 0100 to CIO 0104	00 to 15	CM Output Refresh Area (CM to MM) The data in this area is allocated to the MM Input Refresh Area (CM to MM) for Motion Control Module #1.	
CIO 0105	00 to 07	Reserved.	
	08	Refresh Area for MM #1 CM Input Refresh Area (MM to CM) The data in the MM Output Refresh Area (MM to CM) for MM #1 is allocated here.	Reserved
	09		Cycle time over warning OFF: No error ON: Cycle time exceeded 10 ms.
	10		MM #1 non-fatal error (including FAL instructions) OFF: No non-fatal error ON: Non-fatal error
	11		MM #1 fatal error (including FALS instructions) OFF: No fatal error ON: Fatal error
	12 to 14		Reserved
	15		MM #1 program status OFF: Stopped (PROGRAM mode) ON: Executing (RUN or MONITOR mode)
CIO 0106 to CIO 0109	00 to 15		CM Input Refresh Area (MM to CM) The data in the MM Output Refresh Area (MM to CM) for MM #1 is allocated to this area.
CIO 0110 to CIO 0119	00 to 15	Refresh Area for MM #2	Same as for MM #1. These areas can be used as work bits by the Coordinator Module when no Motion Control Modules are connected.
CIO 0120 to CIO 0129	00 to 15	Refresh Area for MM #3	
CIO 0130 to CIO 0139	00 to 15	Refresh Area for MM #4	

#### Motion Control Module Cyclic Refresh Areas

Motion Control Modules use CIO 0100 to CIO 0109, as shown in the following table.

CM: Coordinator Module  
MM Motion Control Module

Word address	Bits	Details	
CIO 0100	00 to 15	MM Input Refresh Area (CM to this MM) The data in the Coordinator Module's CM Output Refresh Area (CM to MM) is allocated to this area.	General-purpose refresh data from CM to MM.
CIO 0101	00 to 15		
CIO 0102	00 to 15		
CIO 0103	00 to 15		
CIO 0104	00 to 15		

Word address	Bits	Details	
CIO 0105	00 to 07	MM Output Refresh Area (This MM to CM) Data from this area is allocated to the Coordinator Module's CM Input Refresh Area (MM to CM).	Reserved
	08		Reserved
	09		Cycle time over warning OFF: No error ON: MM cycle time exceeded 10 ms.
	10		Non-fatal error for this Motion Control Module (including FAL instructions) OFF: No non-fatal error ON: Non-fatal error
	11		Fatal error for this Motion Control Module (including FALS instructions) OFF: No fatal error ON: Fatal error
	12 to 14		Reserved
	15		Program status for this Motion Control Module OFF: Stopped (PROGRAM mode) ON: Executing (RUN or MONITOR mode)
CIO 0106	00 to 15	General-purpose refresh data from MM to CM	
CIO 0107	00 to 15		
CIO 0108	00 to 15		
CIO 0109	00 to 15		

### 5-3-4 Cyclic Refresh Area Allocations

CM: Coordinator Module  
MM: Motion Control Module

Direction	Motion Control Module allocation			Coordinator Module allocation							
	Word address	Bits	Details	#1		#2		#3		#4	
				Word address	Bit	Word address	Bit	Word address	Bit	Word address	Bit
CM to MM	CIO 0100	00 to 15	General-purpose refresh data from CM to MM	CIO 0100	00 to 15	CIO 0110	00 to 15	CIO 0120	00 to 15	CIO 0130	00 to 15
	CIO 0101	00 to 15		CIO 0101	00 to 15	CIO 0111	00 to 15	CIO 0121	00 to 15	CIO 0131	00 to 15
	CIO 0102	00 to 15		CIO 0102	00 to 15	CIO 0112	00 to 15	CIO 0122	00 to 15	CIO 0132	00 to 15
	CIO 0103	00 to 15		CIO 0103	00 to 15	CIO 0113	00 to 15	CIO 0123	00 to 15	CIO 0133	00 to 15
	CIO 0104	00 to 15		CIO 0104	00 to 15	CIO 0114	00 to 15	CIO 0124	00 to 15	CIO 0134	00 to 15
MM to CM	CIO 0105	00 to 07	Reserved	CIO 0105	00 to 07	CIO 0115	00 to 07	CIO 0125	00 to 07	CIO 0135	00 to 07
		08	Reserved		08		08		08		08
		09	Cycle time over warning		09		09		09		09
		10	Non-fatal error		10		10		10		10
		11	Fatal error		11		11		11		11
		12 to 14	Reserved		12 to 14		12 to 14		12 to 14		12 to 14
		15	Program status		15		15		15		15
	CIO 0106	00 to 15	General-purpose refresh data from MM to CM	CIO 0106	00 to 15	CIO 0116	00 to 15	CIO 0126	00 to 15	CIO 0136	00 to 15
	CIO 0107	00 to 15		CIO 0107	00 to 15	CIO 0117	00 to 15	CIO 0127	00 to 15	CIO 0137	00 to 15
	CIO 0108	00 to 15		CIO 0108	00 to 15	CIO 0118	00 to 15	CIO 0128	00 to 15	CIO 0138	00 to 15
	CIO 0109	00 to 15		CIO 0109	00 to 15	CIO 0119	00 to 15	CIO 0129	00 to 15	CIO 0139	00 to 15

## 5-4 Synchronous Data Refresh

### 5-4-1 Outline

If Sync is set under Synchronization between Modules in the System Setup, each Module will broadcast the specified data (2 types data, 4 words max.) to the Synchronous Data Link Bit Areas each Coordinator Module cycle or specified sync cycle.

Each other Module receives this data. Every Module can access the synchronous data for every other linked Module.

If Synchronization between Modules is set to Sync, the cycle for every Motion Control Module will be automatically synchronized to the Coordinator Module or specified sync cycle, which enables the use of the synchronous Data Link Bit Areas as synchronous data.

The Synchronous Data Link Bit Area is from CIO 0200 to CIO 0219, with 4 words allocated to each Module (Coordinator Module and all Motion Control Modules).

#### Sync Cycle Time

When Sync Mode is set, the Sync Cycle Time can be set under Sync Cycle Time in the Coordinator Module's System Setup. (Default: Coordinator Module cycle time. Setting range: 0.1 to 10.0 ms, Unit: 0.1 ms.)

**Note** Set the Sync Cycle Time longer than the longest cycle time among the synchronized Motion Control Modules.

#### Synchronous Data

Any of the following data can be set as synchronous data for each Module (4 words max.)

- Ladder execution results
- High-speed counter 1/2 PV
- Pulse output 1/2 PV
- Analog input value
- Analog 1/2 output value
- Built-in I/O input

### 5-4-2 Applications

An example application would be the creation of a virtual axis in any Module for all Modules to refer to when synchronizing operation. Another application is for the results of ladder program execution to be used as synchronous data.

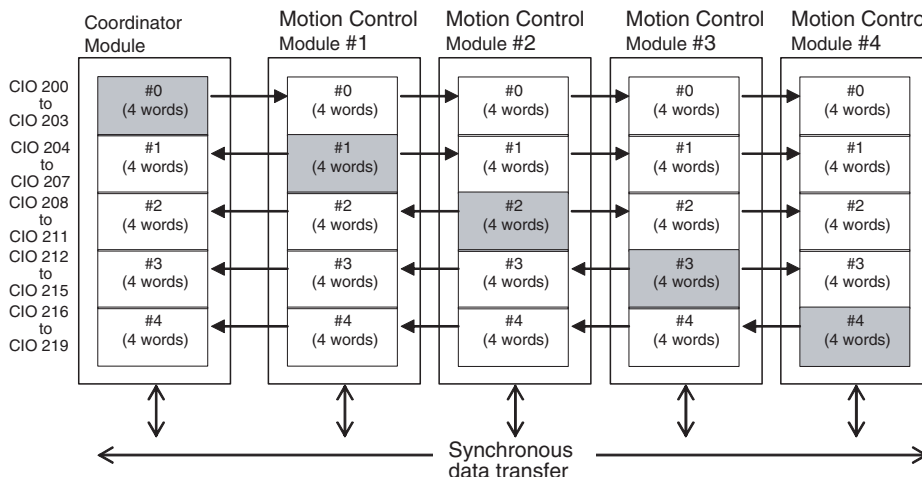

Synchronous Data

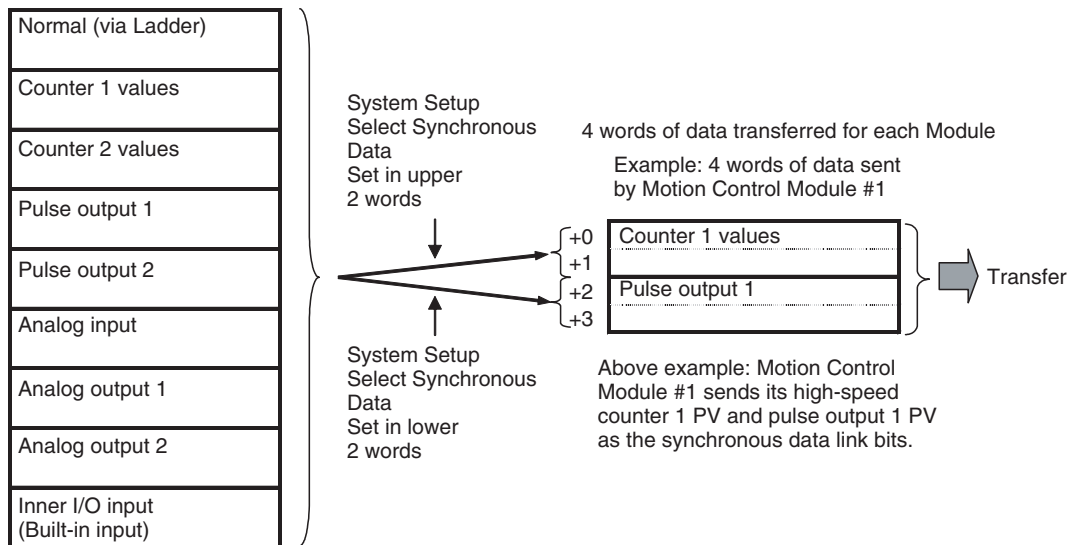

- Note**
- (1) Synchronous data for Coordinator Modules is fixed to general-purpose (ladder execution results) data.
  - (2) If there is no synchronous data to be sent, select no data for *Select Synchronous Data* in the System Setup to shorten the synchronous data transfer time.
  - (3) Auxiliary Area data is transferred when input and output refresh method is set to *Immediate refresh* and the synchronous data is set to an analog input or analog output value in the System Setup.

5-4-3 Synchronous Data Link Bit Area

Synchronous Data Link Bit Areas in Coordinator and Motion Control Modules	Word address (See note 1.)	Bits	Method for selecting type of synchronous data
Sent from Coordinator Module	CIO 0200	00 to 15	Fixed to general-purpose data (e.g., ladder execution results)
	CIO 0201	00 to 15	
	CIO 0202	00 to 15	Fixed to general-purpose data (e.g., ladder execution results)
	CIO 0203	00 to 15	
Sent from Motion Control Module #1	CIO 0204	00 to 15	Set using upper 2 words of <i>Select Synchronous Data</i> in the System Setup for Motion Control Module #1.
	CIO 0205	00 to 15	
	CIO 0206	00 to 15	Set using lower 2 words of <i>Select Synchronous Data</i> in the System Setup for Motion Control Module #1.
	CIO 0207	00 to 15	
Sent from Motion Control Module #2	CIO 0208	00 to 15	Set using upper 2 words of <i>Select Synchronous Data</i> in the System Setup for Motion Control Module #2.
	CIO 0209	00 to 15	
	CIO 0210	00 to 15	Set using lower 2 words of <i>Select Synchronous Data</i> in the System Setup for Motion Control Module #2.
	CIO 0211	00 to 15	
Sent from Motion Control Module #3	CIO 0212	00 to 15	Set using upper 2 words of <i>Select Synchronous Data</i> in the System Setup for Motion Control Module #3.
	CIO 0213	00 to 15	
	CIO 0214	00 to 15	Set using lower 2 words of <i>Select Synchronous Data</i> in the System Setup for Motion Control Module #3.
	CIO 0215	00 to 15	



Synchronous Data Link Bit Areas in Coordinator and Motion Control Modules	Word address (See note 1.)	Bits	Method for selecting type of synchronous data
Sent from Motion Control Module #4	CIO 0216	00 to 15	Set using upper 2 words of <i>Select Synchronous Data</i> in the System Setup for Motion Control Module #4.
	CIO 0217	00 to 15	
	CIO 0218	00 to 15	Set using lower 2 words of <i>Select Synchronous Data</i> in the System Setup for Motion Control Module #4.
	CIO 0219	00 to 15	

- Note**
- (1) Addresses are the same for the Coordinator Module and all Motion Control Modules.
  - (2) When the synchronous data is one-word data (analog input values, analog output values, built-in I/O, etc.), the other word can be used for general-purpose data.

### 5-4-4 Settings

The following settings must be made beforehand when using the synchronous data refresh function.

#### System Setup (Coordinator Module)

*Synchronization between Modules* and *Sync Cycle Time* must be set in the Coordinator Module's System Setup.

#### Synchronization between Modules

Name	Settings	Default	Description	Auxiliary Area Flags	Enabled
Module Settings Tab Page Sync Mode	Sync/Async	Sync	Synchronization between Modules	---	At power ON

#### Sync Cycle Time

Name	Settings	Default	Description	Auxiliary Area Flags	Enabled
Module Settings Tab Page Sync Cycle Time	Default (cycle time) (0.1 to 10.0 ms)	CM cycle time	Sync cycle time (unit: 0.1 ms)	A404.06 Sync Cycle Time Too Long Flag	At power ON

When the Sync Cycle Time is specified, all Motion Control Modules will synchronize with the Coordinator Module cycle time in PROGRAM mode. The specified Sync Cycle Time is enabled in RUN and MONITOR modes, and the Motion Control Module cycle times will change to the set Sync Cycle Time when in these modes.

Synchronous data link bits will be broadcast from each Module at the time specified under Sync Cycle Time.

If an interrupt task 000 is created, it can be used as a regular interrupt task executed each Sync Cycle Time.

When the Sync Cycle Time is on the default setting, the synchronous data link bits are broadcast from each Module each Coordinator Module cycle. The Motion Control Module cycles are synchronous with the Coordinator Module cycle.

- Note** If the Sync Cycle Time Too Long Flag (A404.06) turns ON in the Coordinator Module, it means that the Motion Control Module cycle time is longer than the Sync Cycle Time. Either change the Sync Cycle Time or check the Motion Control Module ladder program and shorten the Motion Control Module cycle time to less than the Sync Cycle Time.

## System Setup (Motion Control Modules)

### Selecting Synchronous Data

Select the type of synchronous data to be sent by each Motion Control Module in the System Setup for that Motion Control Module, as shown in the following table.

Tab page	Function		Settings	Enabled
Module Settings	Select Synchronous Data	Upper 2 words (+0 and +1)	Normal (via Ladder) Counter 1 values	At power ON
		Lower 2 words (+2 and +3)	Counter 2 values Pulse output 1 Pulse output 2 Analog input Reserved Analog output 1 Analog output 2 Inner I/O input (built-in input) No data (See note.)	

**Note** The time for synchronous data exchange can be shortened by selecting No data.

### Prohibit System Interruption of the Sync Mode

Use this function to keep the timing of the calculation start for each Motion Control Module as close as possible, when using Sync Mode.

Name	Function	Settings	Enabled
Module Settings Tab Page Execution Process	Prohibit system interruption of the sync mode	OFF: Allow system interruption of the sync mode ON: Prohibit system interruption of the sync mode	At start of operation

**Caution** Do not set this function to *Prohibit system interruption of the sync mode* when the cycle time is 10 ms or longer. Doing so may cause the System Clock Bits to malfunction.

**Note** Settings are made using the CX-Programmer Ver. 5.0□ menus.

## 5-5 DM Data Transfer

### 5-5-1 Outline

Large volumes of any DM data can be transferred between the Coordinator Module and a Motion Control Module at any specified timing.

- Only DM Area words can be used for transfer in both the Coordinator Module and Motion Control Modules.
- Up to 499 words can be transferred.

Data is transferred in the specified direction between the specified DM Area words in a specified Motion Control Module and the specified DM Area words in the Coordinator Module when the DM Write Request Bit (A530.00) or DM Read Request Bit (A530.01) in the Auxiliary Area of the Coordinator Module is turned ON.

This function is used, for example, to manage data in the Coordinator Module for use by Motion Control Modules when the data must be backed up.

DM data transfer is possible in PROGRAM, RUN, or MONITOR mode for the Coordinator Module and Motion Control Modules.

### 5-5-2 Settings Details

The settings for using the DM data transfer function are made in the Auxiliary Area.

Name	Address	Description	Read/write
DM Write Request Bit (Coordinator Module to Motion Control Module)	A530.00	DM data transfer is executed from the Coordinator Module to Motion Control Module when this bit turns ON.	Enabled
DM Read Request Bit (Motion Control Module to Coordinator Module)	A530.01	DM data transfer is executed from the Motion Control Module to Coordinator Module when this bit turns ON.	
Slot No. of Motion Control Module for DM Transfer	A531	Specifies the slot number (in 4-digit hexadecimal) for the Motion Control Module with which DM data is to be transferred. 0001: Motion Control Module #1 0002: Motion Control Module #2 0003: Motion Control Module #3 0004: Motion Control Module #4	
DM Transfer Size (number of words)	A532	Specifies the size, in number of words, of the DM data to be transferred. 0001 to 01F3 hex (1 to 499 words)	
First DM Transfer Source Word	A533	Specifies the first address of the DM transfer source in the Coordinator Module or Motion Control Module. 0000 to 7FFF hex	
First DM Transfer Destination Word	A534	Specifies the first address of the DM transfer destination in the Coordinator Module or Motion Control Module. 0000 to 7FFF hex	
Transfer Error Flag	A535.14	Turns ON when a DM data transfer error occurs.	
Transfer Busy Flag	A535.15	Turns ON during DM data transfer and turns OFF when the transfer has been completed.	

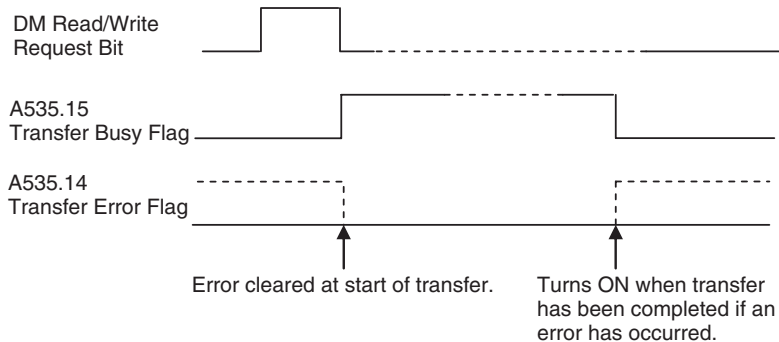

### 5-5-3 Executing DM Data Transfer

#### Step 1: Make Auxiliary Area Settings

To transfer data, the Auxiliary Area settings, described earlier, must be made. The following settings are made in the Auxiliary Area.

- Slot No. of Motion Control Module for DM Transfer  
Specifies the slot number for the Motion Control Module to which DM data is being transferred.
- Transfer details
  - DM Transfer Size (number of words)
  - First DM Transfer Source Word
  - First DM Transfer Destination Word

**Step 2: Turn ON Request Bit**

- Transferring DM Data from the Coordinator Module to a Motion Control Module: Turn ON the DM Write Request Bit (Coordinator Module to Motion Control Module) (A530.00).
- Transferring DM Data from a Motion Control Module to the Coordinator Module: Turn ON the DM Read Request Bit (Motion Control Module to Coordinator Module) (A530.01).

**Programming Example**

The following diagram shows a programming example for the Coordinator Module when transferring DM data from the Coordinator Module (CM) to the Motion Control Module mounted to slot #1 (MM).

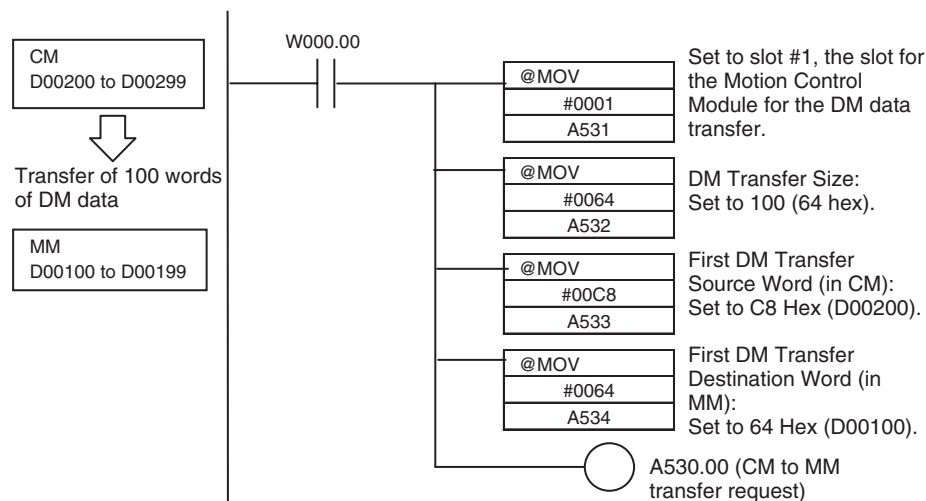

**Note** When executing a DM data transfer from a Motion Control Module to the Coordinator Module (DM read request), do not set the First DM Transfer Source Word to D30000 or higher

## 5-6 Cycle Time Settings

This section describes the constant cycle time function, the watch cycle time function, and the cycle time monitoring function.

### 5-6-1 Constant Cycle Time Function

A constant cycle time can be set with the FQM1 Series. Programs are executed at standard intervals, which allows the control cycles for Servomotors to be constant.

The constant cycle time is set using the Cycle Time setting in the System Setup (0.1 to 100.0 ms, unit: 0.1 ms).

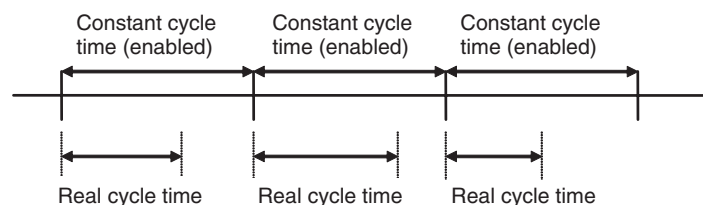

If the real cycle time is longer than the set cycle time, the constant cycle time function will be ignored and operation will be based on the real cycle time.

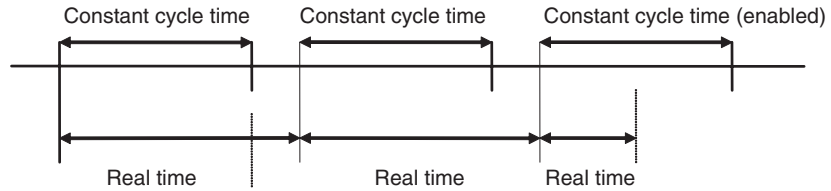

**System Setup**

Tab page	Name	Settings	Default
Timer/Peripheral servicing or Cycle Time	Cycle Time	0.1 to 100.0 ms, 0.1 ms units	Variable

**Constant Cycle Time Exceeded Flag**

Name	Address	Description
Constant Cycle Time Exceeded Flag	A404.05	This flag turns ON when the constant cycle time function is used and the cycle time exceeds the constant cycle time set value.

**Constant Cycle Time Exceeded Error Clear Bit**

Name	Address	Description
Constant Cycle Time Exceeded Error Clear Bit	A509.15	The constant cycle time function can be enabled again after the cycle time has exceeded the constant cycle time and A404.05 has turned ON.

**Constant Cycle Time Function in Sync Mode**

When in Sync Mode with a Sync Cycle Time set for the Coordinator Module cycle time (default), and the constant cycle time function is used, the cycle time for Motion Control Modules will be as described below.

**Constant Cycle Time Function Enabled for Coordinator Module**

The Motion Control Module cycle time is synchronized with the Coordinator Module constant cycle time, and will therefore be constant.

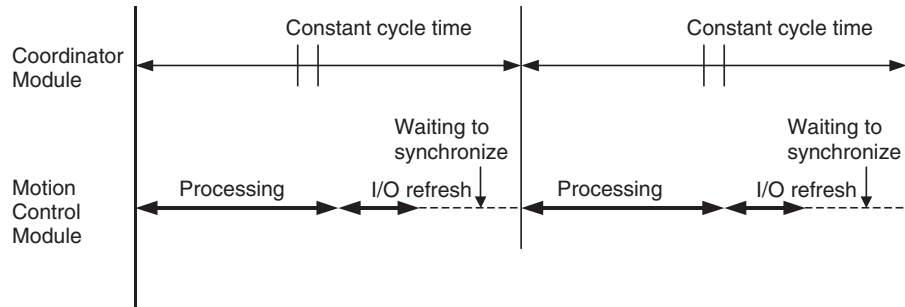

**Constant Cycle Time Function Enabled for Motion Control Module**

The Motion Control Module cycle time is synchronized with the Coordinator Module constant cycle time, and gradually is made constant, while the Motion Control Module's built-in I/O refresh timing is made constant.

The time from when the processing starts in the Motion Control Module until the I/O refresh will be constant.

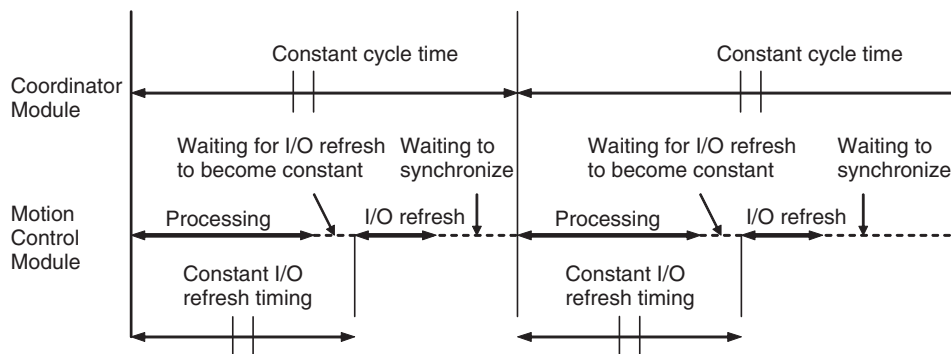

**Note** When the constant cycle time function is enabled for the Motion Control Module in ASync Mode, the Motion Control Module's cycle time will be constant.

### 5-6-2 Watch Cycle Time Function

If the real cycle time is longer than the set watch cycle time, operation will stop for all Modules and the Cycle Time Too Long Flag (A401.08) in the Auxiliary Area will turn ON.

#### System Setup

Tab page	Name	Details	Default
Timer/Peripheral Servicing or Cycle Time	Cycle Time	0.1 to 100.0 ms (unit: 0.1 ms)	Variable
	Watch Cycle Time	1 to 100 ms (unit: 1 ms)	50 ms

**Caution** If the Cycle Time Too Long Flag turns ON for one Module in Sync Mode, the Cycle Time Too Long Flag will turn ON for all Modules.

**Note** The settings are made using CX-Programmer Ver. 5.0□ menus.

#### Cycle Time Too Long Flag

Name	Address	Details
Cycle Time Too Long Flag	A401.08	Turns ON if the cycle time PV exceeds the Watch Cycle Time in the System Setup.

### 5-6-3 Cycle Time Monitoring Function

Every cycle, the maximum cycle time is stored in A206 and A207 and the PV is stored in A208 and A209 in the Auxiliary Area.

#### Auxiliary Area Words

Name	Addresses	Meaning
Maximum Cycle Time	A206 to A207	The maximum cycle time value is stored in binary each cycle. The time is measured in 0.01-ms units.
Cycle Time PV	A208 to A209	The cycle time PV is stored in binary each cycle. The time is measured in 0.01-ms units.

The average cycle time for the last 8 scans can also be read from the CX-Programmer.

**Note** The FQM1 can skip program areas that do not need to be executed by using the JMP-JME instructions to shorten cycle times.

### 5-6-4 Clearing Constant Cycle Time Exceeded Errors

When using the constant cycle time function, normally the cycle time will no longer stay constant (i.e., will vary depending on the real cycle time) if the constant cycle time is exceeded once. To return to a constant cycle time even if the cycle time has been exceeded once, turn ON the Constant Cycle Time Exceeded Error Clear Bit (A509.15) (i.e., set to 1).

This function allows a constant cycle time to be restored and variations in I/O processing time to be kept to a minimum even if the cycle time is temporarily long as a result of special processing, e.g., initialization at the start of user programs in each Module.

#### Normal Operation

The constant cycle time function is cleared if the cycle time exceeds the set constant cycle time.

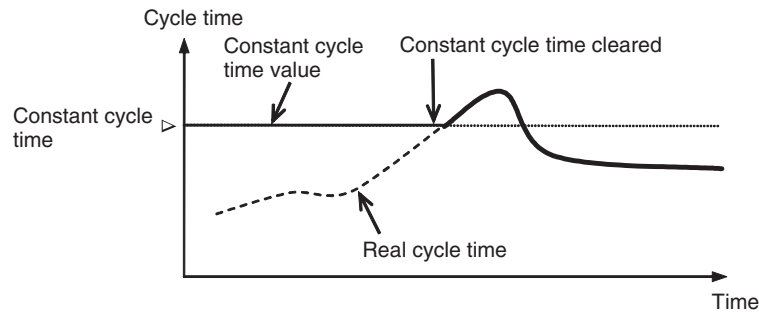

#### Constant Cycle Time Exceeded Error Clear Function

The constant cycle time function can be enabled again by turning ON the Constant Cycle Time Exceeded Clear Bit.

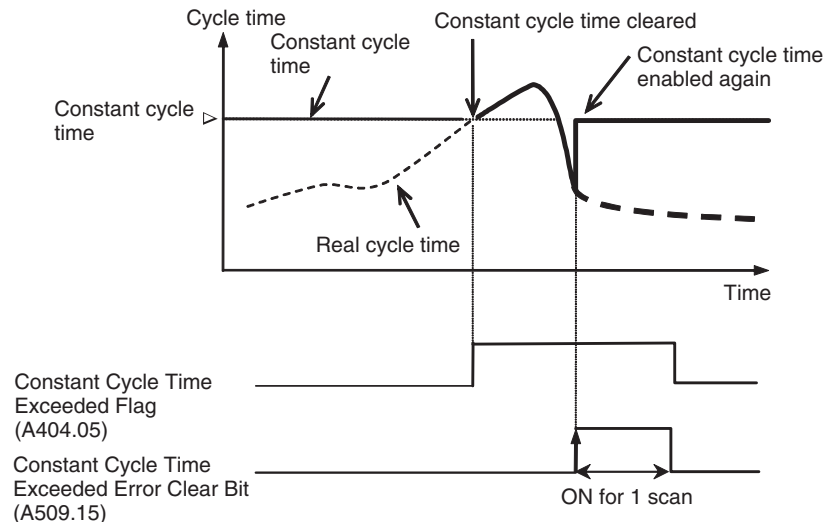

#### Auxiliary Area Bits

	Bit	Function	Controlled by
Constant Cycle Time Exceeded Error Clear Bit	A509.15	OFF to ON: Constant cycle time exceeded error cleared.	User

## 5-7 Operation Settings at Startup and Maintenance Functions

This section describes the following operation settings at startup and maintenance functions.

- Operating mode at startup
- Program protection
- Remote programming and monitoring
- Flash memory

### 5-7-1 Specifying the Startup Mode

The operating mode when the power is turned ON can be specified in the System Setup.

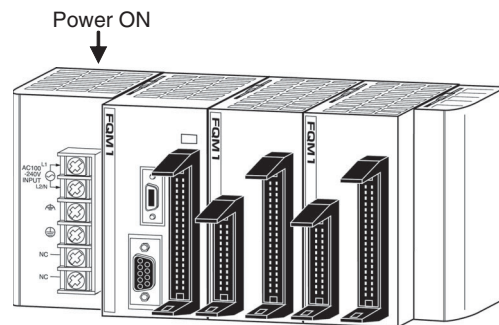

#### System Setup

Tab page	Name	Details	Settings	Default
Startup	Startup Mode	Specifies the initial operating mode when the power is turned ON.	System Setup disabled • RUN mode System Setup enabled • PROGRAM mode • MONITOR mode • RUN mode	System Setup disabled

**Note** The operating mode at startup for Motion Control Modules will be the same as that for the Coordinator Module when in Sync Mode, but will be RUN mode when in ASync Mode.

### 5-7-2 Program Protection

The FQM1 provides the following kinds of protection for user programs.

#### Read Protection Using Passwords

Read and display access to the user program area can be blocked from the CX-Programmer. Protecting the program will prevent unauthorized copying of the program and loss of intellectual property.

A password is set for program protection from the CX-Programmer and read access is prevented to the whole program.

- Note**
- (1) If you forget the password, the program in the FQM1 cannot be transferred to the computer.
  - (2) If you forget the password, programs can be transferred from the computer to the FQM1. Programs can be transferred from the computer to the FQM1 even if the password protection has not been released.



Password Protection

- 1,2,3... 1. Register a password either online or offline.
  - a. Select the Module in the Device Type drop-down menu and select **Properties** from the View Menu.
  - b. Select **Protection** from the PLC Properties Dialog Box and input the password.
2. Set password protection online.
  - a. Select **PLC/Protection/Set**. The Protection Setting Dialog Box will be displayed.
  - b. Click the **OK** Button.

5-7-3 Flash Memory

Automatic Backup to Flash Memory

The user program and parameters are automatically backed up in flash memory whenever they are written.

- The following data is backed up automatically: User program, parameters (including the System Setup, absolute offset data, and analog I/O offset gain adjustment values), and some DM Area data (only for the Coordinator Module).
- The automatic backup is executed whenever the Module user program or parameter area is written (e.g., for data transfer operations from the CX-Programmer and online editing).
- The user program and parameter data written to flash memory is automatically transferred to user memory at startup.

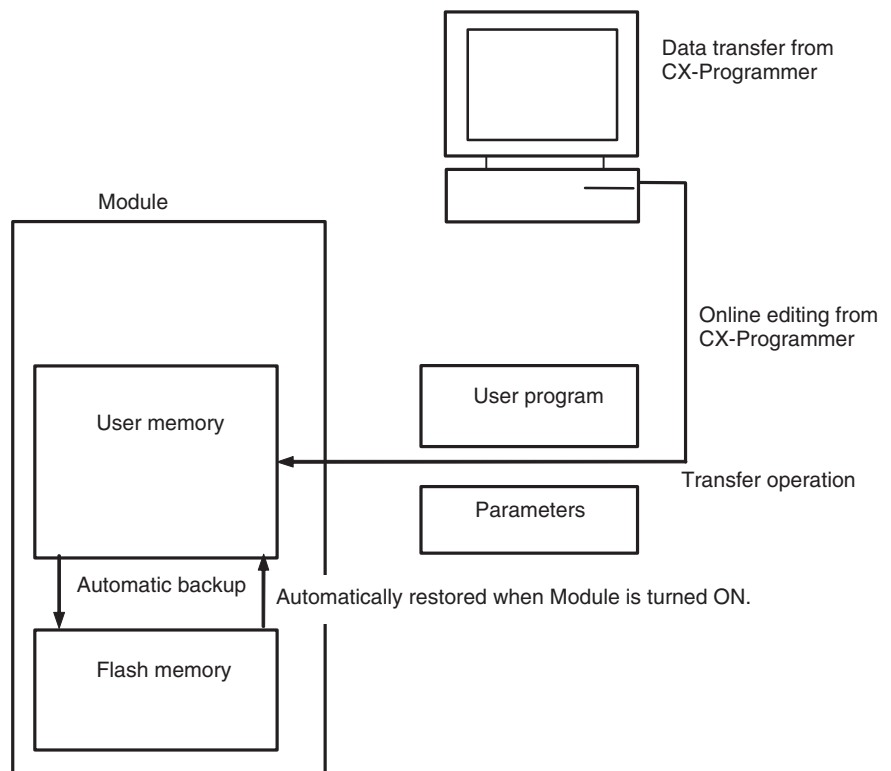

**Note** The backup status will be displayed in a Memory Backup Status Window by the CX-Programmer when backing up data from the CX-Programmer for transfer operations other than normal data transfers (**PLC/Transfer**). To obtain this window, display of the backup status dialog box must be selected

in the PLC properties and **Window/PLC Memory Backup Status** must be selected from the View Menu. For normal transfer operations (**PLC/Transfer**), the backup status will be displayed in the transfer window after the transfer status for the program and other data. Never turn OFF the FQM1 power during these backup operations. The flash memory will be corrupted if the power is turned OFF.

### Auxiliary Area Flags

Name	Address	Meaning
Flash Memory Error Flag	A403.10	Turns ON when the flash memory is corrupted.

## 5-8 Diagnostic Functions

This section provides a brief overview of the following diagnostic and debugging functions.

- Error Log
- Failure Alarm Functions (FAL(006) and FALS(007))

### 5-8-1 Error Log

Each time that an error occurs, the Module stores error information in the Error Log Area. The error information includes the error code (stored in A400) and error contents. Up to 20 records can be stored in the Error Log.

In addition to system-generated errors, the Module records user-defined FAL(006) and FALS(007) errors, making it easier to track the operating status of the system.

Refer to *SECTION 9 Error Processing* for details.

**Note** A user-defined error is generated when FAL(006) or FALS(007) is executed in the program. The input conditions of these instructions constitute the user-defined error conditions. FAL(006) generates a non-fatal error and FALS(007) generates a fatal error that stops program execution.

When more than 20 errors occur, the oldest error data (in A100 to A104) is deleted, the remaining 19 records are shifted down by one record, and the newest record is stored in A195 to A199.

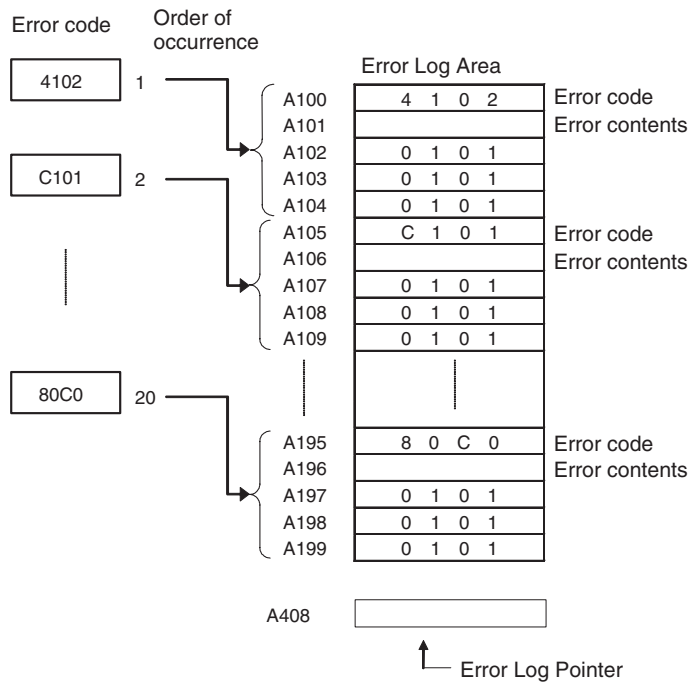

The number of records is stored in binary in the Error Log Pointer (A408). The pointer is not incremented when more than 20 errors have occurred.

**Note** The FQM1 does not support a clock and the time data in the error log will always be 0101.

### 5-8-2 Failure Alarm Functions

The FAL(006) and FALS(007) instructions generate user-defined errors. FAL(006) generates a non-fatal error and FALS(007) generates a fatal error that stops program execution.

When the user-defined error conditions (input conditions for FAL(006) or FAL(007)) are met, the Failure Alarm instruction will be executed and the following processing will be performed.

- 1,2,3...
1. The FAL Error Flag or FALS Error Flag in the Auxiliary Area is turned ON.
  2. The corresponding error code is written to the Auxiliary Area.
  3. The error code is stored in the Error Log.
  4. The error indicator on the front of the Modules will flash or light.
  5. If FAL(006) has been executed, the Modules will continue operating. If FALS(007) has been executed, the Modules will stop operating. (Program execution will stop.)

#### Operation of FAL(006)



When input condition A goes ON, an error with FAL number 2 is generated and A402.15 (FAL Error Flag) is turned ON. Program execution continues.

Errors generated by FAL(006) can be cleared by executing FAL(006) with FAL number 00 or performing the error read/clear operation from the CX-Programmer.

### **Operation of FALS(007)**



When input condition B goes ON, an error with FALS number 3 is generated and A401.06 (FALS Error Flag) is turned ON. Program execution is stopped. Errors generated by FALS(007) can be cleared by eliminating the cause of the error and performing the error read/clear operation from the CX-Programmer.

# SECTION 6



## Coordinator Module Functions

This section describes the serial communications functions, which are supported only by the Coordinator Module.

6-1	Serial Communications . . . . .	124
6-1-1	Host Link Communications . . . . .	126
6-1-2	No-protocol Communications (RS-232C Port) . . . . .	129
6-1-3	NT Link (1:N Mode) . . . . .	131
6-1-4	Serial PLC Links. . . . .	132
6-1-5	Serial Gateway . . . . .	134
6-1-6	No-protocol Communications (RS-422A Port) . . . . .	136

# 6-1 Serial Communications

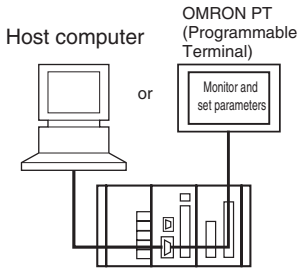
The FQM1 supports the following serial communications functions.

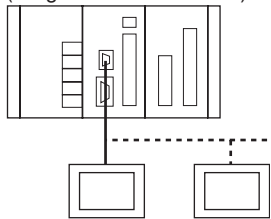
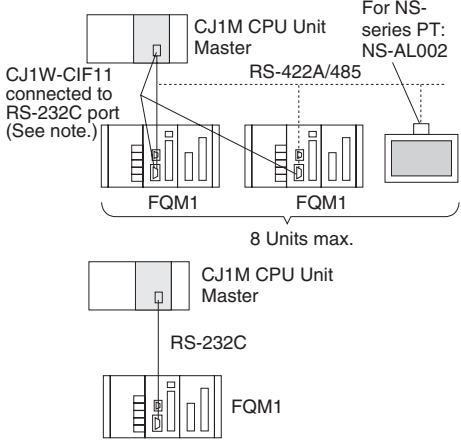

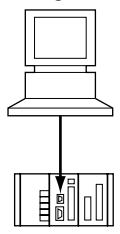
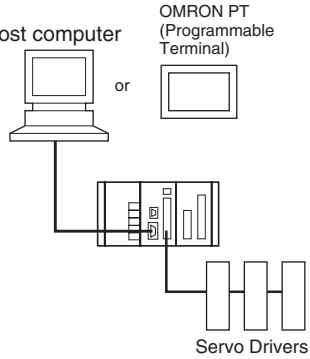
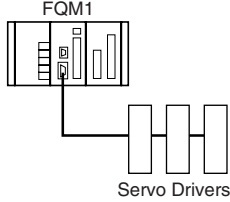
Protocol	Connections	Description	Ports		
			Peripheral	RS-232C	RS-422A
Host Link	<p>Host computer or OMRON PT (Programmable Terminal)</p> 	<p>Various control commands, such as reading and writing I/O memory, changing the operating mode, and force-setting/resetting bits, can be executed by sending Host Link (C-mode) commands or FINS commands from the host computer to the Coordinator Module.</p> <p>Use Host Link communications to monitor data, such as status trace data, or to send data, such as operating conditions information, to the FQM1.</p>	OK	OK	Not allowed
No-protocol	<p>General-purpose external device</p> 	<p>Communicate with general-purpose devices connected to the RS-232C port without a command-response format. The TXD(236) and RXD(235) instructions are executed from the program to transmit data from the send port or read data at the receive port. The frame headers and end codes can be specified.</p>	Not allowed	OK	Not allowed
1:N NT Link (The 1:N NT Link communications are used even for 1:1 connections.)	<p>OMRON PT (Programmable Terminal)</p> 	<p>Data can be exchanged with PTs without using a communications program in the Coordinator Module.</p>	OK	OK	Not allowed
Serial PLC Link Slave		<p>Up to ten words per Module can be shared with up to eight Coordinator Modules as slaves using a CJM1 CPU Unit as the maser.</p> <p>An RS-422A Converter can be connected to the RS-232C port on each Coordinator Module to communicate via RS-422A/485, or one Coordinator Module can communicate via an RS-232C connection to the CJ1M master.</p> <p>The Serial PLC Links can also include PTs as slaves via NT Links (1:N) combined with Coordinator Modules.</p>	Not allowed	OK	Not allowed

Protocol	Connections	Description	Ports		
			Peripheral	RS-232C	RS-422A
Peripheral Bus	Programming Device (CX-Programmer) 	Provides high-speed communications with the CX-Programmer. (Remote programming through modems is not supported.)	OK	OK	Not allowed
Serial Gateway	Host computer or OMRON PT (Programmable Terminal) 	Communications are possible between a host computer or PT connected to the RS-232C port and Servo Drivers connected to the RS-422A port.	Not allowed	Not allowed	OK
No-protocol	FQM1 	TXD(236) and RXD(235) instructions in the Coordinator Module program can be used to send data to and receive data from Servo Drivers.	Not allowed	Not allowed	OK

**Note** The CJ1W-CIF11 is not insulated and the total transmission distance is 50 meters max. If the total transmission distance is greater than 50 meters, use the insulated NT-AL001 and do not use the CJ1W-CIF11. If only the NT-AL001 is used, the total transmission distance is 500 meters max.

### 6-1-1 Host Link Communications

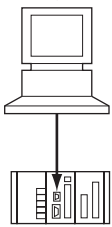
The following table shows the Host Link communication functions available in FQM1. Select the method that best suits your application.

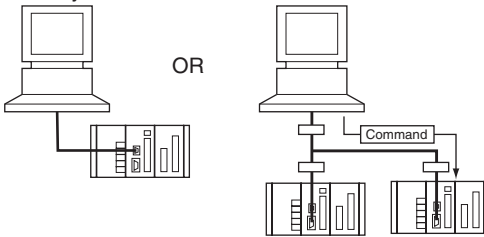
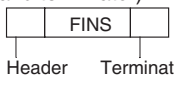
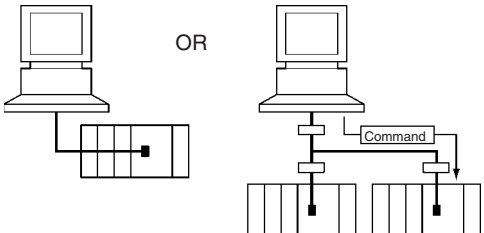
Command flow	Command type	Communications method	Configuration	Application and remarks
Host computer to FQM1 	C-mode (Host Link) commands Host Link command 	Create frame in the host computer and send command to the FQM1. Receive the response from the FQM1.	Directly connect the host computer in a 1:1 or 1:N system. 	Use this method when communicating primarily from the host computer to the FQM1. To use FINS commands, the host computer must send the commands using a Host Link header and terminator.
	FINS command (with Host Link header and terminator) 		Directly connect the host computer in a 1:1 or 1:N system. 	

#### Procedure

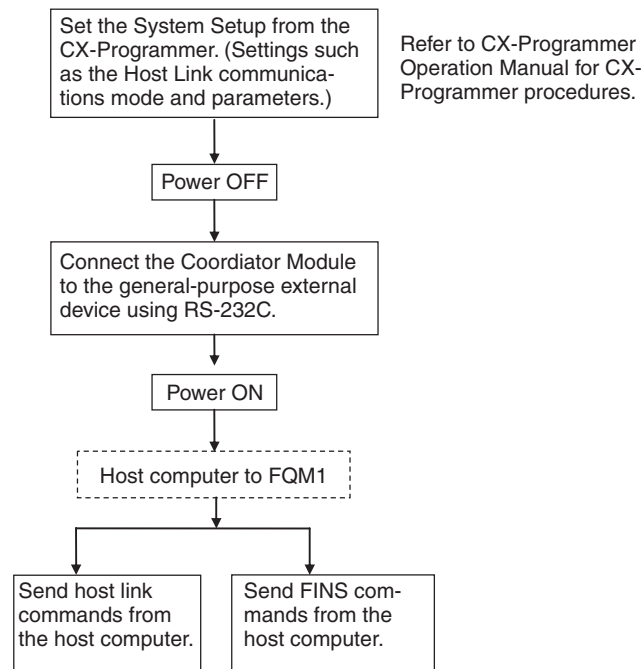

A list of Host Link commands is provided next. Refer to the *C-series Host Link Units System Manual (W143)* for details on Host Link and FINS commands.



**Host Link Commands** The following table lists the Host Link commands. Refer to the *C-series Host Link Units System Manual (W143)* for details.

Type	Header code	Name	Function
Reading I/O memory	RR	CIO AREA READ	Reads the contents of the specified number of CIO Area words, starting from the specified word.
	RC	PV READ	Reads the contents of the specified number of timer/counter PVs (present values), starting from the specified timer/counter.
	RG	T/C STATUS READ	Reads the status of the Completion Flags of the specified number of timers/counters, starting from the specified timer/counter.
	RD	DM AREA READ	Reads the contents of the specified number of DM Area words, starting from the specified word.
	RJ	AR AREA READ	Reads the contents of the specified number of Auxiliary Area words, starting from the specified word.
Writing I/O memory	WR	CIO AREA WRITE	Writes the specified data (word units only) to the CIO Area, starting from the specified word.
	WC	PV WRITE	Writes the PVs (present values) of the specified number of timers/counters, starting from the specified timer/counter.
	WD	DM AREA WRITE	Writes the specified data (word units only) to the DM Area, starting from the specified word.
	WJ	AR AREA WRITE	Writes the specified data (word units only) to the Auxiliary Area, starting from the specified word.
Changing timer/counter set values	R#	SV READ 1	Reads the 4-digit BCD constant or word address in the SV of the specified timer/counter instruction.
	R\$	SV READ 2	Searches for the specified timer/counter instruction beginning at the specified program address and reads the 4-digit constant or word address of the SV.
	R%	SV READ 3	Searches for the specified timer/counter instruction beginning at the specified program address and reads the 4-digit BCD constant or word address of the SV.
Status commands	W#	SV CHANGE 1	Changes the 4-digit BCD constant or word address in the SV of the specified timer/counter instruction.
	W\$	SV CHANGE 2	Searches for the specified timer/counter instruction beginning at the specified program address and changes the 4-digit constant or word address of the SV.
	W%	SV CHANGE 3	Searches for the specified timer/counter instruction beginning at the specified program address and changes the 4-digit constant or word address of the SV.
	MS	STATUS READ	Reads the operating status of the Coordinator Module (operating mode, force-set/reset status, fatal error status).
	SC	STATUS CHANGE	Changes the Coordinator Module's operating mode.
	MF	ERROR READ	Reads errors in the Coordinator Module (non-fatal and fatal).
Force-set/reset commands	KS	FORCE SET	Force-sets the specified bit.
	KR	FORCE RESET	Force-resets the specified bit.
	FK	MULTIPLE FORCE SET/RESET	Force-sets, force-resets, or clears the forced status of the specified bits.
	KC	FORCE SET/RESET CANCEL	Cancel the forced status of all force-set and force-reset bits.
Reading model codes	MM	PLC MODEL READ	Reads the model type of the FQM1.
Test commands	TS	TEST	Returns, unaltered, one block of data transmitted from the host computer.

Type	Header code	Name	Function
Program area access commands	RP	PROGRAM READ	Reads the contents of the Coordinator Module's user program area in machine language (object code).
	WP	PROGRAM WRITE	Writes the machine language (object code) program transmitted from the host computer into the Coordinator Module's user program area.
Compound reading of I/O memory	QQMR	COMPOUND COMMAND	Registers the desired bits and words in a table.
	QQIR	COMPOUND READ	Reads the registered words and bits from I/O memory.
Processing Host Link communications	XZ	ABORT (command only)	Aborts the Host Link command that is currently being processed.
	**	INITIALIZE (command only)	Initializes the transmission control procedure of all Host Link Units connected to the host computer.
	IC	Undefined command (response only)	This response is returned if the header code of a command was not recognized.

**FINS Commands**

The following table lists the FINS commands. Refer to the *C-series Host Link Units System Manual (W143)* for details.

Type	Command code		Name	Function
I/O Memory Area Access	01	01	MEMORY AREA READ	Reads consecutive data from the I/O memory area.
	01	02	MEMORY AREA WRITE	Writes consecutive data to the I/O memory area.
	01	03	MEMORY AREA FILL	Fills the specified range of I/O memory with the same data.
	01	04	MULTIPLE MEMORY AREA READ	Reads non-consecutive data from the I/O memory area.
	01	05	MEMORY AREA TRANSFER	Copies and transfers consecutive data from one part of the I/O memory area to another.
Parameter Area Access	02	01	PARAMETER AREA READ	Reads consecutive data from the parameter area.
	02	02	PARAMETER AREA WRITE	Writes consecutive data to the parameter area.
	02	03	PARAMETER AREA FILL	Fills the specified range of the parameter area with the same data.
Program Area Access	03	06	PROGRAM AREA READ	Reads data from the user program area.
	03	07	PROGRAM AREA WRITE	Writes data to the user program area.
	03	08	PROGRAM AREA CLEAR	Clears the specified range of the user program area.
Execution Control	04	01	RUN	Switches the Coordinator Module to RUN or MONITOR mode.
	04	02	STOP	Switches the Coordinator Module to PROGRAM mode.
Configuration Read	05	01	CONTROLLER DATA READ	Reads Coordinator Module information.
	05	02	CONNECTION DATA READ	Reads the model numbers of the specified Units.
Status Read	06	01	CONTROLLER STATUS READ	Reads the Coordinator Module's status information.
	06	20	CYCLE TIME READ	Reads the average, maximum, and minimum cycle times.
Message Access	09	20	MESSAGE READ/CLEAR	Reads/clears messages and FAL(S) messages.
Access Right	0C	01	ACCESS RIGHT ACQUIRE	Acquires the access right if no other device holds it.
	0C	02	ACCESS RIGHT FORCED ACQUIRE	Acquires the access right even if another device currently holds it.
	0C	03	ACCESS RIGHT RELEASE	Releases the access right regardless of what device holds it.
Error Access	21	01	ERROR CLEAR	Clears errors and error messages.
	21	02	ERROR LOG READ	Reads the error log.
	21	03	ERROR LOG CLEAR	Clears the error log pointer to zero.

Type	Command code		Name	Function
Forced Status	23	01	FORCED SET/RESET	Force-sets, force-resets, or clears the forced status of the specified bits.
	23	02	FORCED SET/RESET CANCEL	Cancels the forced status of all force-set and force-reset bits.

### 6-1-2 No-protocol Communications (RS-232C Port)

No-protocol Mode is used to send and receive data using the communications port TXD(236) and RXD(235) I/O instructions in the Coordinator Module ladder program, without using retry processing, data conversion, branch processing based on received data, or other communications procedures and without converting the data.

No-protocol mode can be used with the RS-232C and RS-422A ports in the Coordinator Module. Data can be sent or received in one direction only between the Module and the general-purpose external device connected to the RS-232C or RS-422A port.

For example, data can be input from a bar code reader or output to a printer, or parameter data can be sent and received from a host controller.

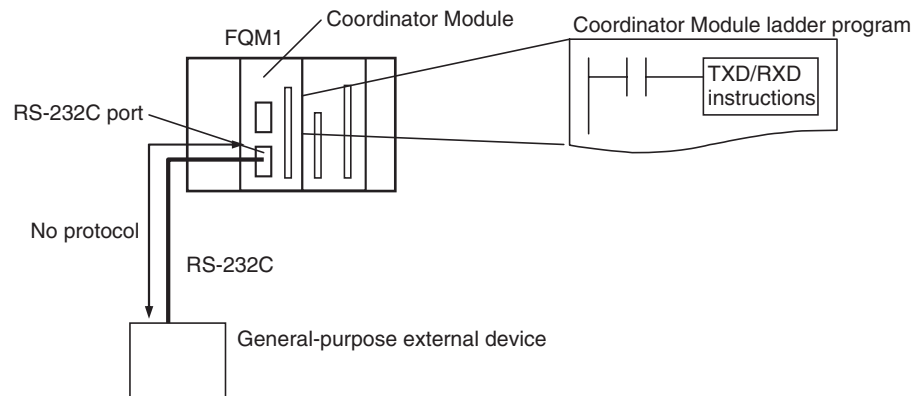

The following table lists the no-protocol communications functions available for the FQM1.

Send/receive	Transfer direction	Method	Max. amount of data	Frame format		Other functions
				Start code	End code	
Sending data	FQM1 to General-purpose external device	Execute TXD(236) in the program	256 bytes	Yes: 00 to FF No: None	Yes: 00 to FF CR+LF None (Specify reception data size to between 1 and 256 bytes when set to none.)	<ul style="list-style-type: none"> <li>Send delay time (delay between TXD(236) execution and sending data from specified port): 0 to 99,990 ms (unit: 10 ms)</li> <li>RS and ER signal ON/OFF</li> </ul>
Receiving data	General-purpose external device to FQM1	Execute RXD(235) in the program	256 bytes			Monitoring of CS and DR signals

**Procedure**

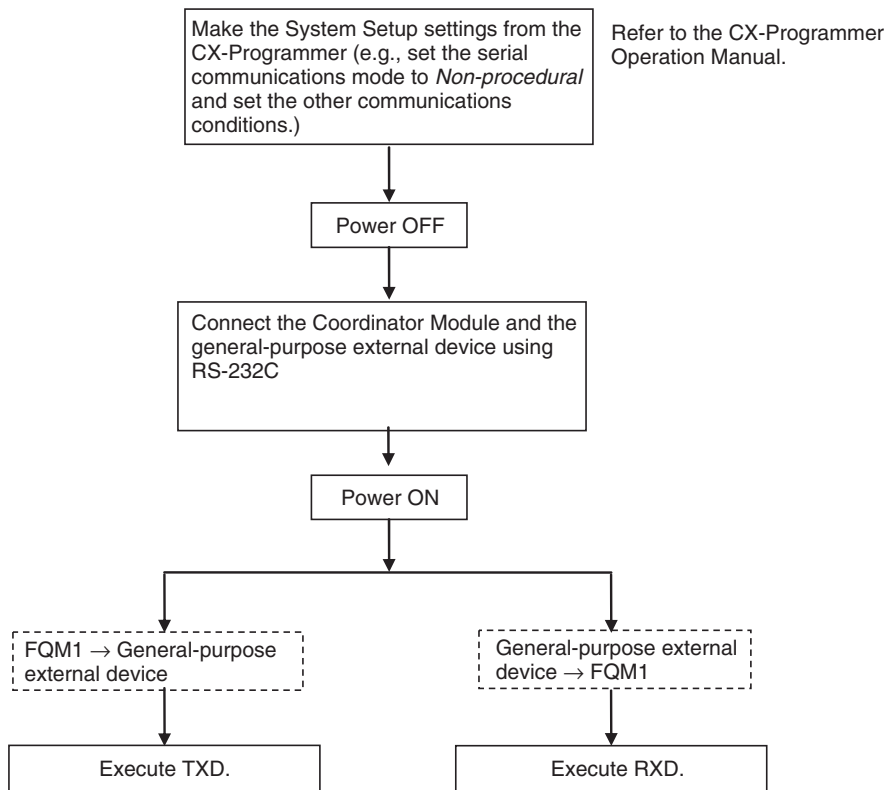

**Message Frame Formats**

Data can be placed between a start code and end code for transmission by TXD(236) and frames with that same format can be received by RXD(235). When transmitting with TXD(236), just the data from I/O memory is transmitted, and when receiving with RXD(235), just the data itself is stored in specified area in I/O memory.

Up to 256 bytes (not including the start and end codes) can be transferred each time TXD(236) or RXD(235) are used. The start and end codes are specified in the System Setup.

**Message Frame Formats for No-protocol Mode Transmission and Reception**

Item		End code setting		
		No	Yes	CR+LF
Start code setting	No	<div style="border: 1px solid black; padding: 5px; display: inline-block;">Data</div> 256 bytes max.	<div style="display: inline-block; border: 1px solid black; padding: 5px;">Data</div> <div style="display: inline-block; border: 1px solid black; padding: 5px; margin-left: 5px;">ED</div> 256 bytes max.	<div style="display: inline-block; border: 1px solid black; padding: 5px;">Data</div> <div style="display: inline-block; border: 1px solid black; padding: 5px; margin-left: 5px;">CR+LF</div> 256 bytes max.
	Yes	<div style="display: inline-block; border: 1px solid black; padding: 5px; margin-right: 5px;">ST</div> <div style="border: 1px solid black; padding: 5px; display: inline-block;">Data</div> 256 bytes max.	<div style="display: inline-block; border: 1px solid black; padding: 5px; margin-right: 5px;">ST</div> <div style="display: inline-block; border: 1px solid black; padding: 5px; margin-right: 5px;">Data</div> <div style="display: inline-block; border: 1px solid black; padding: 5px; margin-left: 5px;">ED</div> 256 bytes max.	<div style="display: inline-block; border: 1px solid black; padding: 5px; margin-right: 5px;">ST</div> <div style="display: inline-block; border: 1px solid black; padding: 5px; margin-right: 5px;">Data</div> <div style="display: inline-block; border: 1px solid black; padding: 5px; margin-left: 5px;">CR+LF</div> 256 bytes max.

- When more than one start code is used, the first start code will be valid.
- When more than one end code is used, the first end code will be valid.
- If the data being transferred contains the end code, the data transfer will be stopped midway. In this case, change the end code to CR+LF.

**Note** The transmission of data after the execution of TXD(236) can be delayed by a specified transmission delay time, as shown in the following diagram.

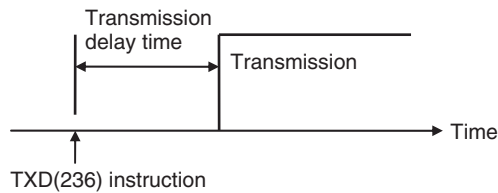

Refer to the *Instructions Reference Manual* (Cat. No. O011) for more details on the TXD(236) and RXD(235) instructions.

**System Setup**

**RS-232C Settings (Host Link Port Settings)**

Item	Setting	Default	Enabled
Mode	RS-232C	Host Link	Each cycle
Delay	0 to 99,990 ms (unit: 10 ms)	0 ms	
End Code	00 to FF hex	00 hex	
Start Code	00 to FF hex	00 hex	
Received bytes	1 to 255 bytes	256 bytes	
Use of end code	Received bytes or CR+LF	Received bytes	
Use of start code	None	None	

**Note** The settings are made using CX-Programmer Ver. 5.0□ menus.

**6-1-3 NT Link (1:N Mode)**

With the FQM1, communications are possible with PTs (Programmable Terminals) using NT Links (1:N mode).

**Note** Communications are not possible using the 1:1-mode NT Link protocol. Also, the standard baud rate must be used.

The settings can be made using System Setup and the PT system menu.

**System Setup**

Communications port	Name	Settings contents	Default	Other conditions
Peripheral port	Mode	NT Link (1:N mode)	Host Link	Turn ON pin 2 on the Coordinator Module DIP switch.
	Baud	Standard NT Link	Standard NT Link	
	NT Link max.	0 to 7	0	
RS-232C port	Mode	NT Link (1:N mode)	Host Link	---
	Baud	Standard NT Link	Standard NT Link	
	NT Link max.	0 to 7	0	

**PT System Menu**

Set the PT as follows:

- 1,2,3...** 1. Select NT Link (1:N) from the Comm. A Method or Comm. B Method on the Memory Switch Menu in the System Menu on the PT.
2. Press the SET Touch Switch to set the Comm. Speed to Standard. High-speed communications are not possible.

### 6-1-4 Serial PLC Links

#### Overview

The FQM1 can be connected to a Serial PLC Link by linking to a Serial PLC Master. (It cannot be connected by the Complete Link Method.) Program-free data exchange can be achieved between the master and slave by connecting a CJ1M CPU Unit as the master and the FQM1 as the slave. The FQM1 connection is made to the RS-232C port on the Coordinator Module.

CIO 0080 to CIO 0099 in the Serial PLC Link Bit Area in the Coordinator Module are shared with the CJ1M master as shown below.

CIO 0080 to CIO 0089: CJ1M master to FQM1 slave

CIO 0090 to CIO 0099: FQM1 slave to CJ1M master

**Note** Use a CJ1W-CIF11 RS-232C to RS-422A/485 Conversion Adapter when connecting more than one FQM1 to the same CJ1M CPU Unit (1:N, where N = 8 max.).

Up to 10 words can be sent by the CJM1 and FQM1. Fewer words can be sent by setting the number of link words, but the number of words will be the same for both the CJM1 and FQM1.

#### System Configuration

##### 1:N Connection between CJ1M and FQM1 Controllers (8 Nodes Max.)

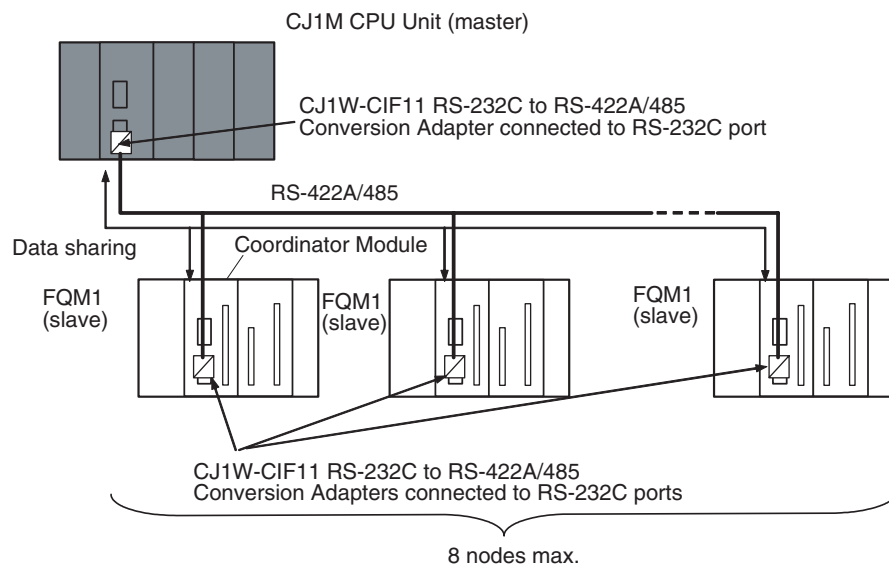

##### 1:1 Connection between CJ1M and FQM1 Controller

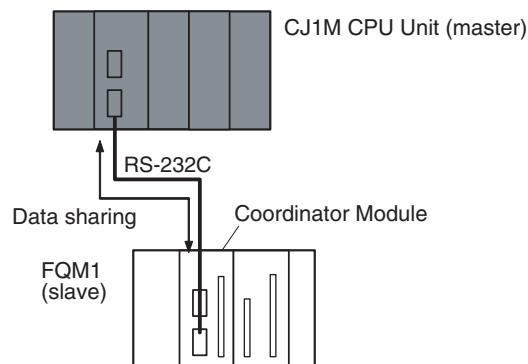

**Direction of Data Transfer**

For example, if the number of link words is set to 10, the CJ1M CPU Unit (master) will broadcast CIO 3100 to CIO 3109 from its I/O memory and to CIO 0080 to CIO 0089 in the I/O memory of each FQM1 Controller (slaves). Each FQM1 Controller will send CIO 0090 to CIO 0099 from its I/O memory to consecutive sets of 10 words in the CJ1M CPU Unit.

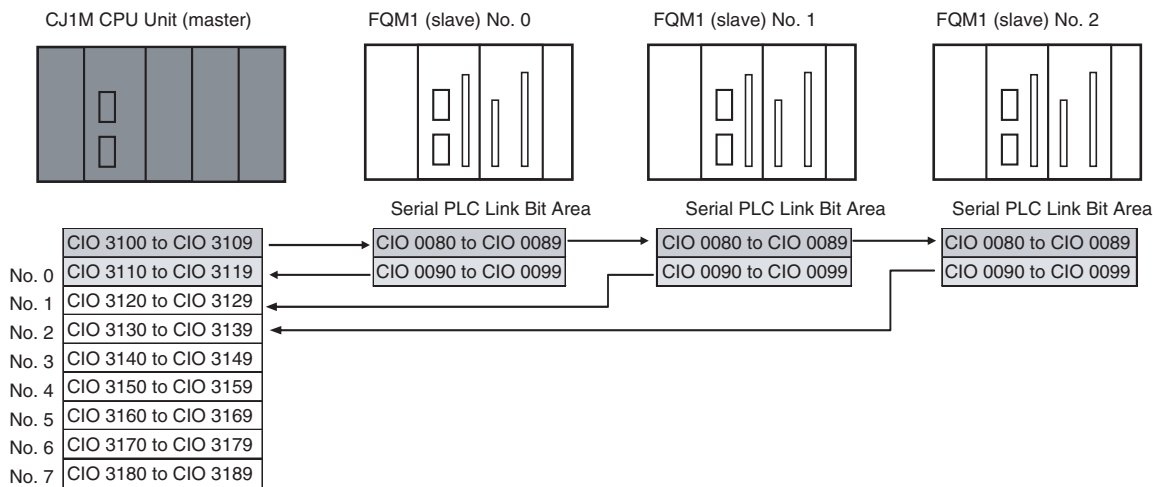

**Source Words and Number of Link Words**

The words that will be sent depend on the number of link words as shown in the following table.

Send direction	Send words				
	No. of link words	1 word	2 words	3 words	... 10 words
CJ1M (master) to (FQM1) slave		(CIO 3100)	(CIO 3100 to CIO 3101)	(CIO 3100 to CIO 3102)	... (CIO 3100 to CIO 3109)
CJ1M to FQM1 No. 0		CIO 0080	CIO 0080 to CIO 0081	CIO 0080 to CIO 0082	... CIO 0080 to CIO 0089
CJ1M to FQM1 No. 1					
CJ1M to FQM1 No. 2					
CJ1M to FQM1 No. 3					
CJ1M to FQM1 No. 4					
CJ1M to FQM1 No. 5					
CJ1M to FQM1 No. 6					
CJ1M to FQM1 No. 7					

**Note** CJ1M CPU Unit I/O memory addresses are given in parentheses.

**Procedure**

The Serial PLC Links operate according to the following settings in the PLC Setup and System Setup.

**CJ1M (Master) Settings**

- 1,2,3...**
1. Set the serial communications mode of the RS-232C communications port to Serial PLC Links (Polling Unit).
  2. Set the link method to the Polling Unit Link Method.
  3. Set the number of link words (1 to 10).
  4. Set the maximum unit number in the Serial PLC Links (0 to 7).

**FQM1 (Slave) Settings**

- 1,2,3...**
1. Set the serial communications mode of the RS-232C communications port to *PC Link (Slave)*.
  2. Set the unit number of the Serial PLC Link slave.

**Settings****CJ1M (Master) PLC Setup**

Item		Address		Set value	Default	Refresh timing
		Word	Bits			
RS-232C port setting	Serial communications mode	160	08 to 11	8 hex: Serial PLC Links Polling Unit	0 hex	Every cycle
	Port baud rate	161	00 to 07	00 to 09 hex: Standard (0A hex: High-speed cannot be used.)	00 hex	
	Link method	166	15	ON: Polling Unit links (OFF: Complete links cannot be used.)	0	
	Number of link words		04 to 07	1 to A hex	0 hex (See note 1.)	
	Highest unit number		00 to 03	0 to 7 hex	0 hex	

- Note**
- (1) Automatically allocates 10 words (A hex) when the default setting of 0 hex is used.
  - (2) Connection to the FQM1 is not possible at 115,200 bits/s.

**FQM1 (Slave) System Setup**

Item		Set value	Default	Refresh timing
RS-232C port settings	Mode	7 hex: PC Link (Slave)	Host Link	Every cycle
	Baud	00 to 09 hex: Standard (0A hex: High-speed cannot be used.)	Standard (38,400:1, 8, 1, 0)	
	PC Link Unit No.	0 to 7 hex	0 hex	

**Note** The settings are made using CX-Programmer Ver. 5.0□ menus.

**6-1-5 Serial Gateway****Serial Gateway Function**

Servo parameters and other data can be read and written from NS-series PTs or personal computers (applications that operate on the CX-Server) to Servo Drivers that are connected to the FQM1 Coordinator Module's RS-422A port. This function can be executed by setting the FQM1 Coordinator Module's RS-422A serial communications mode to Serial Gateway.

**RS-422A-compatible Servo Drivers**

OMRON W-series and OMRON SMARTSTEP Servo Drivers.

**System Configuration**

Example: Accessing a W-series or SMARTSTEP Servo Driver from Smart Active Parts on a NS-series PT using an NT Link



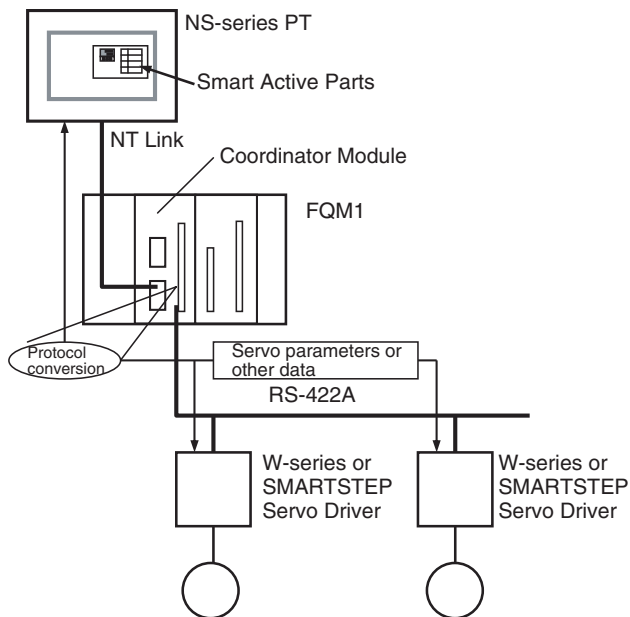

**Note** When the Serial Gateway function is used, the FQM1 receives FINS commands (encapsulated W-series or SMARTSTEP commands) via the RS-422A port from NT-series PTs or personal computers and converts them to W-series or SMARTSTEP Servo Driver commands (removes the encapsulation) and transfers them to the W-series or SMARTSTEP Servo Drivers.

**System Setup**

Item		Settings	Default	Enabled
Drive Tab Page	Mode	Serial Gateway or Non-procedural (no-protocol)	Serial Gateway	Each cycle
	RS-422 Response Time-out of Command	0.1 to 25.5 s (unit: 0.1 s)	5 s	

**Note** The settings are made using CX-Programmer Ver. 5.0□ menus.

**Smart Active Parts Communications Settings**

When using NS-series Smart Active Parts for Servo Drivers with the FQM1, set the Destination Unit No. (U) to 251 on the Smart Active Parts Communications Settings Screen. No. 251 indicates the RS-422A port for the FQM1.

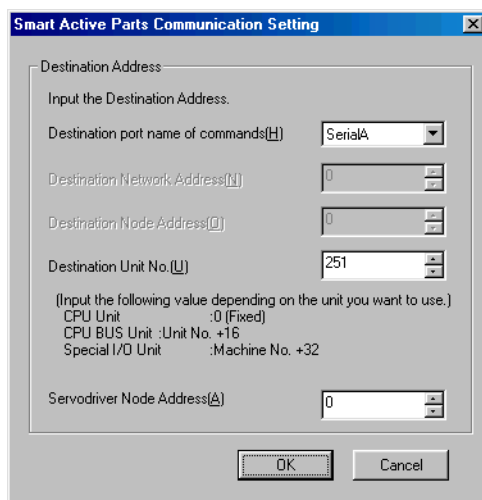

### 6-1-6 No-protocol Communications (RS-422A Port)

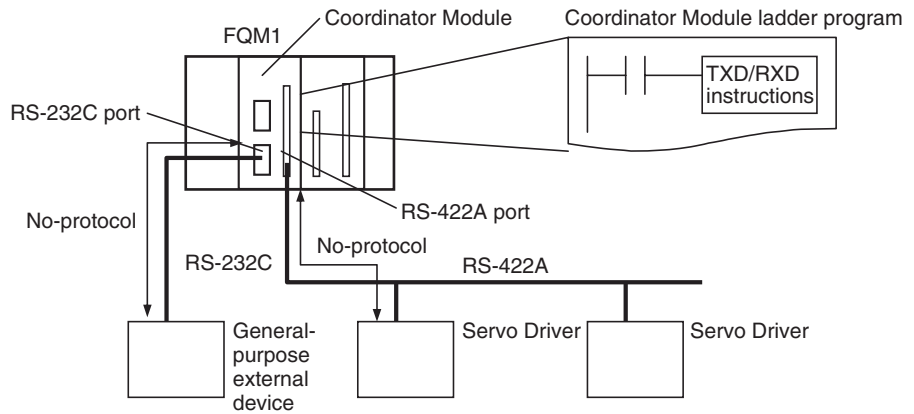

#### RS-422A Settings

Item	Settings	Default	Enabled
Mode	No-protocol	Serial Gateway	Each cycle
Delay	0 to 99,990 ms (unit: 10 ms)	0 ms	
End code	00 to FF hex	00 hex	
Start code	00 to FF hex	00 hex	
Received bytes	01 to FF hex: 1 to 255 bytes	256 bytes	
Use of end code	Received bytes or CR+LF	Received bytes	
Use of start code	No Yes	No	

**Note** The settings are made using CX-Programmer Ver. 5.0□ menus.

# SECTION 7

## Motion Control Module Functions

This section describes the various functions supported by the Motion Control Module.

7-1	Overview . . . . .	139
7-2	Interrupt Functions . . . . .	140
7-2-1	Overview . . . . .	140
7-2-2	Interrupt Priority . . . . .	140
7-2-3	Disabling and Enabling All Interrupts . . . . .	141
7-3	Input Interrupts . . . . .	142
7-3-1	Applicable Models . . . . .	142
7-3-2	Overview of the Input Interrupt Function . . . . .	142
7-3-3	Interrupt Modes . . . . .	142
7-3-4	Input Interrupt Specifications . . . . .	142
7-3-5	Using Input Interrupts . . . . .	143
7-3-6	Application Example . . . . .	145
7-4	Interval Timer Interrupts . . . . .	146
7-4-1	Applicable Models . . . . .	146
7-4-2	Overview . . . . .	146
7-4-3	Interval Timer Interrupt Modes . . . . .	146
7-4-4	Using Interval Timer Interrupts . . . . .	146
7-4-5	Application Example . . . . .	147
7-5	Pulse Inputs . . . . .	148
7-5-1	Applicable Models . . . . .	148
7-5-2	Outline . . . . .	148
7-5-3	Specifications . . . . .	148
7-5-4	Pulse Input Specifications . . . . .	150
7-5-5	Latch Input Specifications . . . . .	152
7-5-6	Applicable Instructions . . . . .	152
7-5-7	Internal Circuit Configurations . . . . .	152
7-5-8	Pulse Input Function Description . . . . .	153
7-5-9	Pulse Input Function Procedures . . . . .	160
7-5-10	Pulse Input Function Example Application . . . . .	162
7-6	Pulse Outputs . . . . .	167
7-6-1	Applicable Models . . . . .	167
7-6-2	Outline . . . . .	167
7-6-3	Specifications . . . . .	168
7-6-4	Pulse Output Specifications . . . . .	169
7-6-5	Applicable Instructions . . . . .	170
7-6-6	Pulse Output Function Details . . . . .	171
7-6-7	One-shot Pulse Output Function . . . . .	176
7-6-8	Time Measurement with the Pulse Counter . . . . .	178
7-6-9	Target-value Comparison Interrupts from Pulse Output PVs . . . . .	179

7-6-10	Range Comparison Bit Pattern Outputs from Pulse Output PVs . . .	182
7-6-11	Acceleration/Deceleration Rates in ACC(888) and PLS2(887) Instructions . . . . .	182
7-6-12	PLS2(887) Pulse Output Direction Priority Mode . . . . .	183
7-6-13	Pulse Output Function Procedures . . . . .	184
7-6-14	Pulse Output Function Examples . . . . .	189
7-6-15	Pulse Output Starting Conditions . . . . .	194
7-7	Functions for Servo Drivers Compatible with Absolute Encoders . . . . .	199
7-7-1	Applicable Models . . . . .	199
7-7-2	Overview . . . . .	199
7-7-3	Data Format of Absolute Encoder Output. . . . .	200
7-7-4	Counter Operation . . . . .	201
7-7-5	Absolute Number of Rotations PV (Counter 1: A604 and A605) . .	202
7-7-6	Absolute Present Value . . . . .	202
7-7-7	Absolute Present Value Preset. . . . .	203
7-7-8	Absolute Offset Preset. . . . .	203
7-7-9	Related Areas . . . . .	204
7-7-10	Overview of Absolute Encoder Output Data Acquire. . . . .	207
7-7-11	Timing Chart of the Functions for Servo Drivers Compatible with Absolute Encoders. . . . .	209
7-7-12	Sample Programs (Connecting an OMRON W-series Servo Driver)	209
7-8	Virtual Pulse Output Function . . . . .	212
7-8-1	Applicable Models . . . . .	212
7-8-2	Overview . . . . .	212
7-8-3	AXIS Instruction (For Virtual Pulse Outputs). . . . .	213
7-8-4	Application Example. . . . .	215
7-9	Analog Input Functions . . . . .	215
7-9-1	Applicable Models . . . . .	215
7-9-2	Overview . . . . .	215
7-9-3	Analog Input Function Specifications. . . . .	217
7-9-4	Related Areas and Settings . . . . .	218
7-9-5	Applicable Instructions . . . . .	222
7-9-6	A/D Conversion Value. . . . .	222
7-9-7	High-speed Analog Sampling (FQM1-MMA21 Only). . . . .	223
7-10	Analog Outputs . . . . .	225
7-10-1	Applicable Models . . . . .	225
7-10-2	Outline. . . . .	225
7-10-3	Analog Output Function Specifications . . . . .	226
7-10-4	Applicable Instructions . . . . .	228
7-10-5	Procedure. . . . .	229
7-10-6	Application Example. . . . .	230

# 7-1 Overview

The FQM1 Modules have the following functions.

Main function (Applicable Modules)	Sub-functions		
Basic interrupt functions (FQM1-MMP21/MMA21)	Input Interrupts (4 points) (Input Interrupt Mode or Counter Mode)		
	Interval Timer Interrupt (1 point) Setting range: 0.5 to 99,990 ms Unit: 0.1 ms	Scheduled Interrupts One-shot Interrupts	
Constant Cycle Time Exceeded Error Clear Function			
High-speed Counters (FQM1-MMP21/MMA21)	High-speed Counter PVs (2 points) Phase differential, Increment/decrement, or Pulse + direction; 50 kHz or 500 kHz	No interrupts	
		Target Value Comparison Interrupts (Count check interrupts)	
		Range Comparison and Bit Pattern Outputs	
	High-speed Counter Movement Measurement Sampling time (1 to 9,999 ms) or cycle time		
	High-speed Counter Frequency Measurement Measured frequency: 0 to 500 kHz (1 point)		
High-speed Counter Latch (2 latch inputs) (Latched high-speed counter PV can be read with PRV(881) instruction.)			
Functions for Servo Drivers Compatible with Absolute Encoders (FQM1-MMP21/MMA21)	Absolute Number of Rotations PV		
	Absolute PV		
	Absolute PV Preset Function		
	Absolute Offset Preset Function		
Pulse Outputs (FQM1-MMP21 only)	Pulse Outputs (2 points) Pulse output without acceleration/deceleration, non-trapezoidal acceleration or deceleration, trapezoidal acceleration/deceleration, and electronic cam control		
	One-shot Pulse Output Pulse ON time: 0.01 to 9,999 ms		
	Pulse Counter (for time measurement) Measurement unit: Select 0.001 ms, 0.01 ms, 0.1 ms, or 1 ms. Measurement range: 0000 0000 to FFFF FFFF hex		
	These three interrupt/bit pattern output settings can be set for the Pulse Outputs, One-shot Pulse Outputs, and Pulse Counter Functions listed above.	No interrupts	
		Target Value Comparison Interrupts (Count check interrupts) Range Comparison and Bit Pattern Outputs	
Virtual Pulse Outputs (FQM1-MMP21/MMA21)	The AXIS instruction generates trapezoidal acceleration/deceleration in a virtual axis.		
Analog Outputs (FQM1-MMA21 only)	Sloped Output by Instruction (2 points) 1 to 5 V, 0 to 5 V, 0 to 10 V, or -10 to 10 V		
	Immediate refreshing at instruction execution, analog output value hold function, offset/gain adjustment supported		
Analog Inputs (FQM1-MMA21 only)	Immediate Refreshing by Instruction (1 point) 1 to 5 V, 0 to 5 V, 0 to 10 V, -10 to 10 V, or 4 to 20 mA		
	Offset/Gain Adjustment of Analog Input Value		
	High-speed Analog Sampling The CTBL(882) instruction starts analog sampling when the high-speed counter 1 PV matches the preset target value.		

## 7-2 Interrupt Functions

### 7-2-1 Overview

The Motion Control Modules support the following interrupts.

#### Executing Interrupt Programs in the FQM1

The programming routines that are executed for all of the following interrupts are programmed as interrupt tasks.

#### Input Interrupts

Inputs to the Motion Control Module's built-in contact inputs 0 to 3 can be set as interrupt inputs. If they are set as interrupt inputs, an interrupt will be generated when the input turns ON, OFF, or both. If they are set for Counter Mode, an interrupt will be generated when a specified counter value is reached.

#### Interval Timer Interrupts

An interrupt will be generated for an interval timer that can be set to a precision of 0.1 ms. Interval timer interrupts can also be used in the Coordinator Module.

#### High-speed Counter Interrupts

An interrupt will be generated when the PV of the counter equals a preset target value.

#### Pulse Output Interrupts

An interrupt will be generated when the PV of the pulse output (or the pulse counter's PV/measured time) equals a preset target value.

**Note** In addition to interrupts, bit patterns can be output internally when the PV is within a specified range in Range Comparison Mode. High-speed counter PVs, pulse output PVs, pulse counter timer PVs, and one-shot pulse elapsed times can be used as the PVs for bit pattern output.

### 7-2-2 Interrupt Priority

A specified interrupt task will be executed when an interrupt is generated. The priority of interrupts is shown below.

If an additional interrupt occurs while another interrupt is already being processed, the new interrupt will be executed after the first interrupt task has been completed.

If two or more interrupts occur simultaneously, the higher-priority interrupt will be executed first. Interrupts have the following priority:

- Input interrupt 0 → Input interrupt 1 → Input interrupt 2 → Input interrupt 3
- Interval timer interrupt → Pulse output 1 interrupt → Pulse output 2 interrupt → High-speed counter 1 interrupt → High-speed counter 2 interrupt

An instruction controlling a port operation cannot be programmed in an interrupt task if an instruction in the main program is already controlling pulse I/O or a high-speed counter for the same port. If this is attempted, the ER Flag will turn ON. The following instructions are included: INI(880), PRV(881), CTBL(882), SPED(885), PULS(886), PLS2(887), ACC(888), and STIM(980).

This situation can be avoided with the programming methods shown in the following diagram.

Method 1:  
Disabling all interrupts  
in the main program

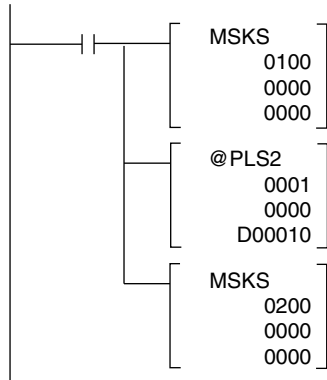

Method 2:  
Executing the routine in the main program instead of  
the interrupt task, where it could not be executed.

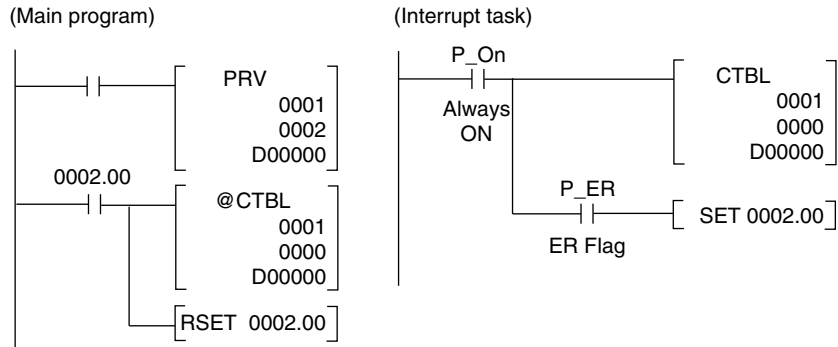

**Note** Only one interrupt task number is recorded for pulse output and high-speed counter interrupts. When a pulse output or high-speed counter interrupt is on standby (because another interrupt is being executed or interrupts are disabled) and another interrupt occurs, the earlier interrupt task number is replaced with the most recent interrupt task number. Design the system to allow sufficient time between interrupts for the length of the interrupt tasks to prevent unwanted conflicts between interrupts.

### 7-2-3 Disabling and Enabling All Interrupts

All interrupts can be disabled using the DI(802) instruction, as shown below. The following interrupts are disabled and enabled by DI(802) and EI(694).

- Input interrupts
- Interval timer interrupts
- High-speed counter interrupts
- Pulse output interrupts

Observe the following precautions when using DI(802).

- DI(802) and EI(694) cannot be used within an interrupt task to disable or enable interrupts.
- Do not use DI(802) to disable all interrupts unless there is a specific need to do so.

#### Disabling All Interrupts

The DI(802) instruction will disable all interrupts.

```
— [ (@)DI      ]
```

**Note** Interrupt processing will not be executed for an interrupt that occurs while interrupts are disabled, but the interrupt event will be recorded for each type of interrupt and interrupt processing will be executed when interrupts are enabled.

#### Enabling All Interrupts

The EI(694) instruction clears the prohibition on all interrupts that was set with the DI(802) instruction.

```
— [ (@)EI      ]
```

**Note** Executing the EI(694) instruction merely returns the interrupts to the status they were in before all interrupts were prohibited (disabled by DI(802)).

The EI(694) instruction does not enable all interrupts. If an interrupt was masked before all interrupts were disabled, that interrupt will still be masked after the prohibition on all interrupts is cleared.

### Clearing Recorded Interrupts

The CLI(691) instruction clears the interrupt event information recorded while all interrupts were disabled by the DI(802) instruction.

## 7-3 Input Interrupts

### 7-3-1 Applicable Models

Model number	Functions
FQM1-MMP21	Motion Control Module for Pulse I/O
FQM1-MMA21	Motion Control Module for Analog I/O

### 7-3-2 Overview of the Input Interrupt Function

Contact inputs 0 to 3 in the Motion Control Modules can be used for external interrupt inputs. These inputs correspond to CIO 0000.00 to CIO 0000.03. The interrupt tasks corresponding to these inputs are fixed and cannot be changed. Contact inputs 0 to 3 call interrupt tasks 000 to 003, respectively.

**Note** If the input interrupts are not being used, interrupt tasks 000 to 003 can be used as interrupt tasks for other interrupt functions.

### 7-3-3 Interrupt Modes

There are two modes that can be used for the input interrupts. Each of the four interrupt inputs can be set to either of these modes.

- **Input Interrupt Mode:**  
An interrupt is generated when the external input turns ON, OFF, or both.
- **Counter Mode:**  
External signals are counted, decrementing the PV from an SV, and an interrupt is generated when the PV equals 0.

The interrupt mode for each interrupt input is set using the MSKS(690) instruction.

### 7-3-4 Input Interrupt Specifications

#### Input Interrupt Mode

Item	Specification
Interrupt condition	Contact inputs 0 to 3 (CIO 0000.00 to CIO 0000.03) turn ON, OFF, or both <b>Note</b> Set the interrupt condition in the System Setup.
Interrupt task numbers	CIO 0000.00 to CIO 0000.03: Interrupt tasks 000 to 003
Response time	0.1 ms for ON interrupt condition The response time is measured from when interrupt condition is met until interrupt task execution starts.
Signal pulse width	ON: 0.1 ms min., OFF: 0.2 ms min.



**Counter Mode**

Item	Specification
Interrupt condition	Counter decremented from SV each time input contacts 0 to 3 (CIO 0000.00 to CIO 0000.03) turn ON, OFF, or both and PV reaches 0. <b>Note</b> Set the interrupt condition in the System Setup.
Interrupt task numbers	CIO 0000.00 to CIO 0000.03: Interrupt tasks 000 to 003 (fixed)
Counter operation	Decrementing pulse input
Input method	Single phase
Counting speed	2 kHz
Counter value	0000 to FFFF hex
Counter PV storage	Input interrupts 0 to 3 (CIO 0000.00 to CIO 0000.03): A524 to A527
Counter SV storage	Input interrupts 0 to 3 (CIO 0000.00 to CIO 0000.03): A520 to A523

**7-3-5 Using Input Interrupts**

**Input Interrupt Mode Procedure**

- 1,2,3... 1. Determine which input interrupt number will be used.  
2. Wire the input.

Input	Allocated input bit	Interrupt task number
External interrupt input 0	CIO 0000.00	000
External interrupt input 1	CIO 0000.01	001
External interrupt input 2	CIO 0000.02	002
External interrupt input 3	CIO 0000.03	003

3. Make the necessary System Setup settings.
- Set the Interrupt Input Settings (set whether an interrupt will be generated when the input turns ON, OFF, or both).
- Note** The default input setting is for a normal input.
4. Create the necessary ladder programming.
- Use the MSKS(690) instruction (SET INTERRUPT MASK) to enable the input as an interrupt input.
  - Create the interrupt task program.

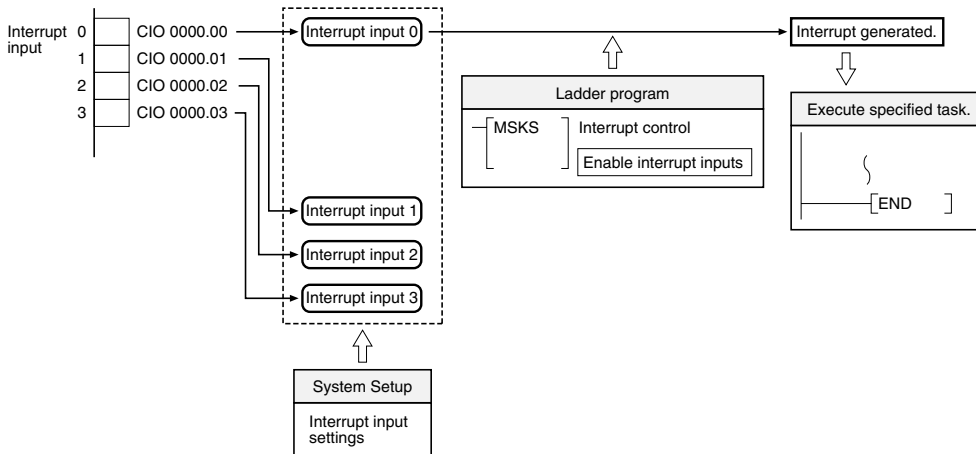

**Counter Mode Procedure**

- 1,2,3...
1. Determine which input interrupt number will be used.
  2. Determine the initial SV for the decrementing counter.
  3. Wire the input.

Input	Allocated input bit	Interrupt task number
External interrupt input 0	CIO 0000.00	000
External interrupt input 1	CIO 0000.01	001
External interrupt input 2	CIO 0000.02	002
External interrupt input 3	CIO 0000.03	003

4. Make the necessary System Setup settings.
  - Set the Interrupt Input Settings (set whether an interrupt will be generated when the input turns ON, OFF, or both).
  - Note** The default input setting is for a normal input.
5. Create the necessary ladder programming.
  - Use the MSKS(690) instruction (SET INTERRUPT MASK) to refresh the counter's SV in counter mode.
  - Create the interrupt task program.

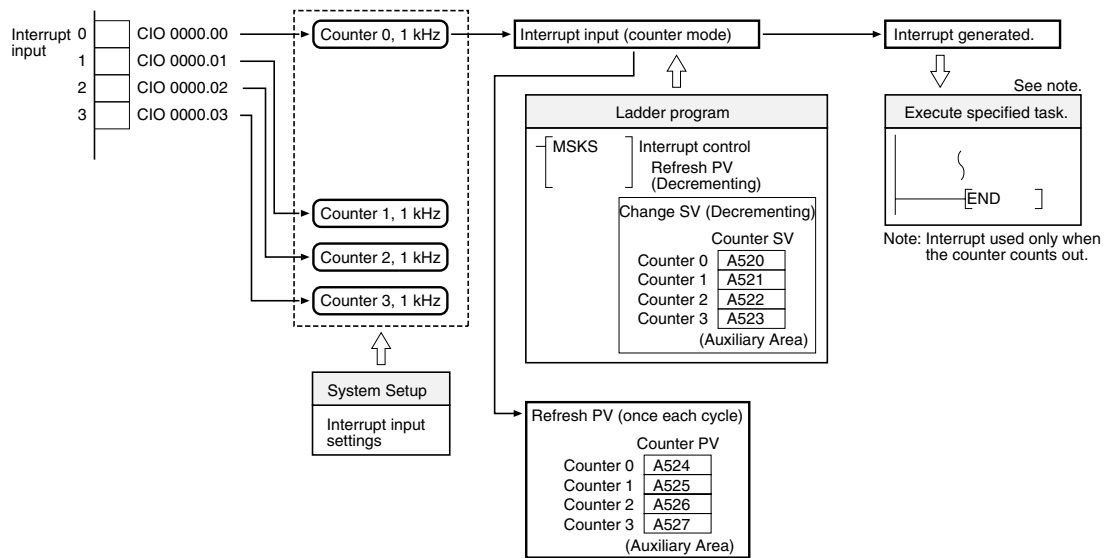

### 7-3-6 Application Example

This example shows input interrupt 0 and input interrupt 1 used in interrupt input mode and counter mode, respectively.

Before executing the program, verify that the following System Setup settings have been made: input 0 and input 1 both set to *Interruption (up)*. The other System Setup settings are set to their default settings.

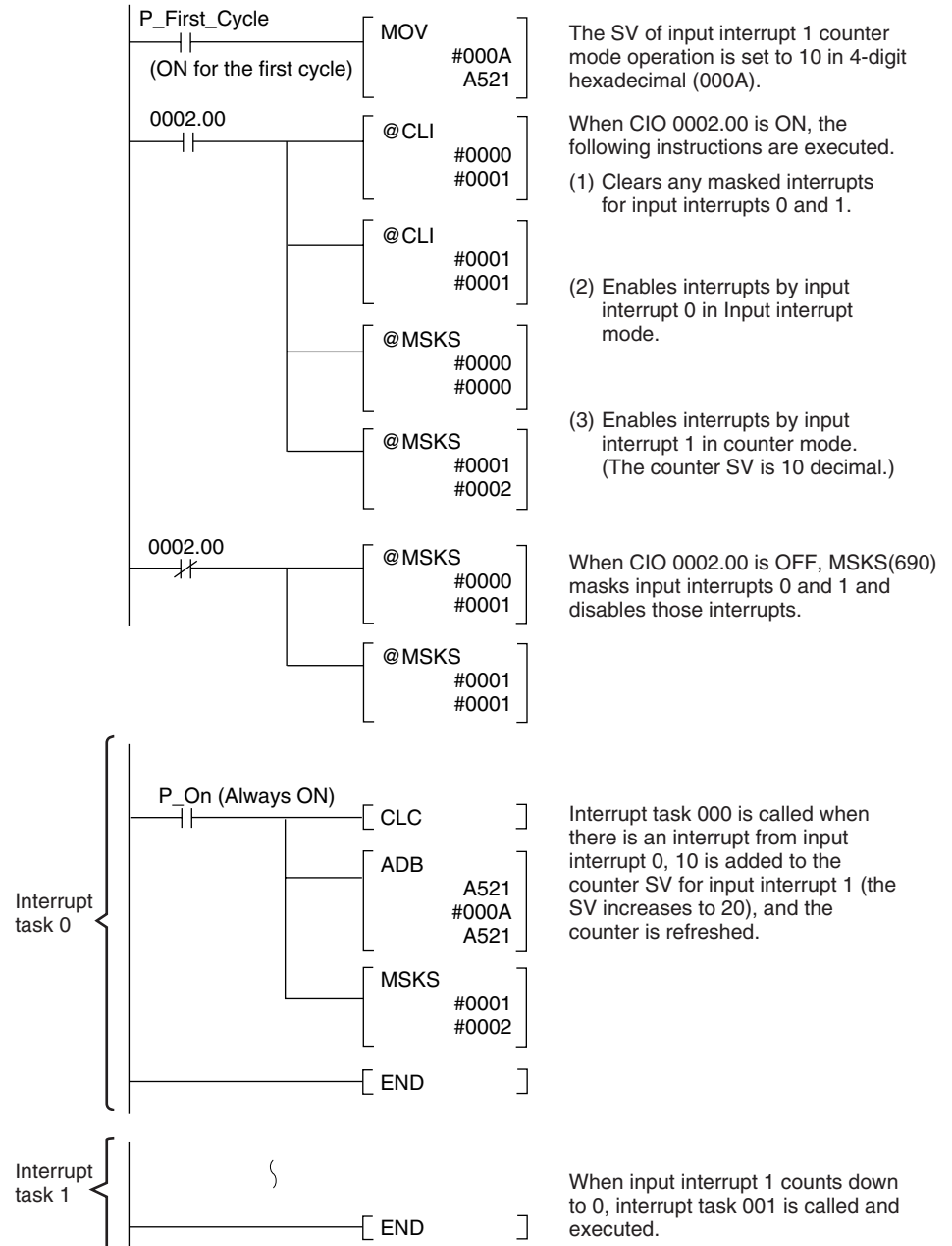

The following timing chart shows the operation of the program as it is executed.

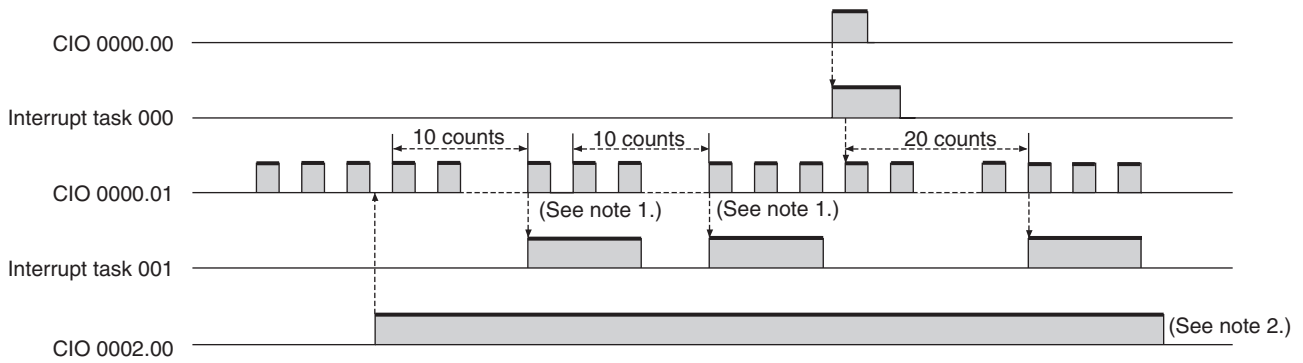

- Note**
- (1) Counting continues even while the interrupt task is being executed.
  - (2) The input interrupts are masked after this point.

## 7-4 Interval Timer Interrupts

### 7-4-1 Applicable Models

Model number	Functions
FQM1-CM001	Coordinator Module
FQM1-MMP21	Motion Control Module for Pulse I/O
FQM1-MMA21	Motion Control Module for Analog I/O

### 7-4-2 Overview

Interval timers can be used to perform high-speed, high-precision timer interrupt processing. The Motion Control Modules and Coordinator Module are equipped with one interval timer each.

### 7-4-3 Interval Timer Interrupt Modes

There are two modes for interval timer operation.

- One-shot Mode  
In one-shot mode, the interrupt is executed just once when the timer times out.
- Scheduled Interrupt Mode  
In scheduled interrupt mode, the timer is reset to the SV each time it times out so the interrupt is repeated regularly at a fixed interval.

### 7-4-4 Using Interval Timer Interrupts

- 1,2,3...**
1. Interrupt Mode
    - Determine whether the timer will operate in one-shot mode or scheduled interrupt mode.
  2. Ladder Programming
    - Use the STIM(980) instruction to set the timer SV and start the timer in one-shot or scheduled interrupt mode.
    - Create the interrupt task program.

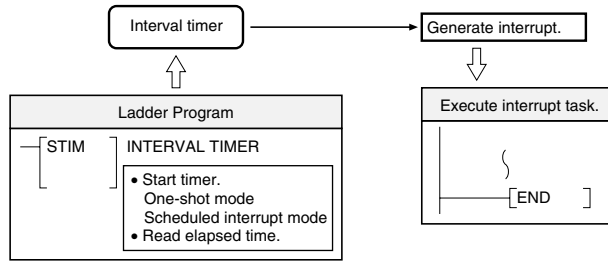

### 7-4-5 Application Example

In this example, the interval timer is used to generate an interrupt every 2.4 ms (0.6 ms × 4). The default System Setup settings are used. (Inputs are not refreshed for interrupt processing.)

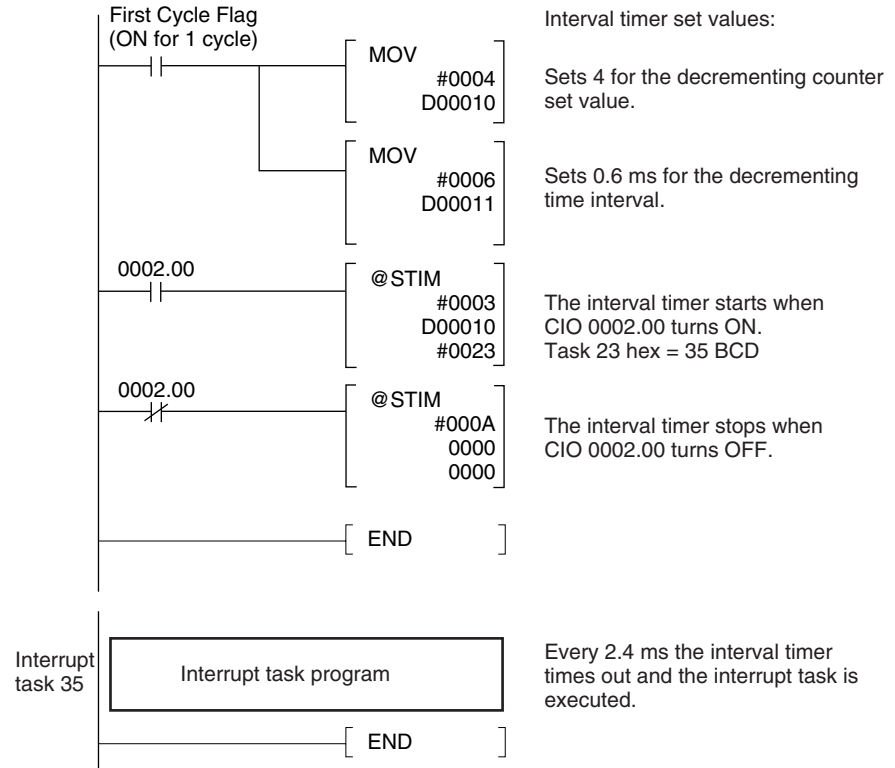

When the program is being executed, the interrupt task will be executed every 2.4 ms while CIO 0002.00 is ON, as shown in the following diagram.

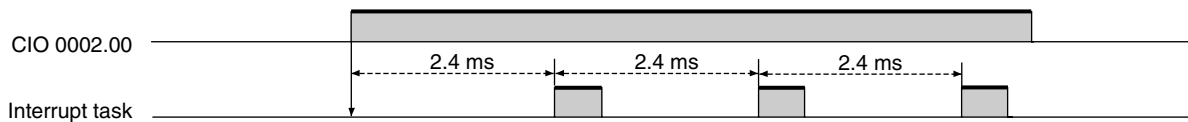

## 7-5 Pulse Inputs

### 7-5-1 Applicable Models

Model	Functions
FQM1-MMP21	Motion Control Module for Pulse I/O
FQM1-MMA21	Motion Control Module for Analog I/O

### 7-5-2 Outline

The FQM1-MMP21 and FQM1-MMA21 Motion Control Modules can receive pulse inputs. The following table shows the processes that can be performed by combining the pulse input function with the high-speed counters to count pulse signals from a rotary encoder or other device and perform processing based on the counter PV.

Process	Description
Target value comparison interrupts	An interrupt task is executed when the high-speed counter PV equals a preset target value.
Bit pattern outputs for range comparisons	When the high-speed counter PV is within a specified range, the user-set bit pattern specified in the comparison table is output internally.
Measurement modes 1 and 2	Movement in the high-speed counter or input pulse counting speed can be displayed while monitoring the high-speed counter PV.
High-speed counter PV latch	High-speed counters 1 and 2 each have a latch register. Two latch inputs can be used to capture the high-speed counter PVs at high speed.

**Note** Interrupts cannot be generated for range comparisons. Only bit patterns are output.

The high-speed counter PV movement during a fixed time interval (equivalent to the travel distance) and the high-speed counter's frequency can also be monitored as required.

### 7-5-3 Specifications

Item			Specification		
Number of counters			2		
Pulse input operation mode (Set in System Setup.)			Phase differential	Increment/decrement	Pulse + direction
Input pin numbers	High-speed counter 1	High-speed counter 2			
	24 V: 1 (5) LD: 3 (5)	24 V: 2 (6) LD: 4 (6)	Phase A	Increment pulse	Pulse
	24 V: 7 (11) LD: 9 (11)	24 V: 8 (12) LD: 10 (12)	Phase B	Decrement pulse	Direction pulse
	24 V: 13 (17) LD: 15 (17)	24 V: 14 (18) LD: 16 (18)	Phase Z	Reset pulse	Reset pulse
Input method			Phase differential ×1, ×2, or ×4 (switchable)	Single-phase ×2	Single-phase + direction
			Set in the System Setup. (Set input for pulse input counter 1 and counter 2.)		
Counting speed (Set separately for each port in the System Setup.)			50 kHz (default) or 500 kHz (2 MHz when using phase differential ×4)		
Counter operation			Linear Counter or Circular Counter (Set in the System Setup.)		

Item		Specification
Counter values		Linear Counter: 8000 0000 to 7FFF FFFF hex Circular Counter: 0000 0000 to Circular maximum count (hex) (The circular maximum count is set in the System Setup between 0000 0001 and FFFF FFFF hex.)
High-speed counter PV storage locations		High-speed counter 1: A601 (upper bytes) and A600 (lower bytes) High-speed counter 2: A603 (upper bytes) and A602 (lower bytes) These values can be used for target-value comparison interrupts or range-comparison bit pattern outputs. <b>Note</b> The PVs are refreshed during the Motion Control Module's I/O refresh. The PVs can also be read with the PRV(881) instruction.  Data storage format: 8-digit hexadecimal • Linear Counter: 8000 0000 to 7FFF FFFF hex • Circular Counter: 0000 0000 to Circular maximum count
Latch inputs		There are two latch inputs. One latch input can be for each high-speed counter or both latch inputs can be used for one high-speed counter. It is also possible for both high-speed counters to share one latch input. The latched PV can be read with the PRV(881) instruction.
Control method	Target value comparison	Register up to 48 target values and interrupt tasks.
	Range comparison	Register up to 16 upper limits, lower limits, and output bit patterns.
Counter reset		Phase Z Signal + Software Reset The counter is reset on the phase-Z signal if the Reset Bit is ON. Software Reset The counter is reset when the Reset Bit is turned ON. <b>Note</b> The counter reset method is set in System Setup.  Reset Bits A610.01 is the Reset Bit for high-speed counter 1 and A611.01 is the Reset Bit for high-speed counter 2.
Measurement mode	Counter movements (mode 1)	Measures the change in the high-speed counter's PV for the set sampling time or each cycle. Sampling time: 1 to 9,999 ms Movement (absolute value): 0000 0000 to FFFF FFFF hex
	Counter frequency (mode 2)	The frequency is calculated from the PV between 0 and 500,000 Hz.
	Measurement storage location for above measurements	High-speed counter 1: A605 (upper bytes) and A604 (lower bytes) High-speed counter 2: A607 (upper bytes) and A606 (lower bytes) <b>Note</b> The high-speed counter value can also be read with the PRV(881) instruction.
		Stored Data Movement: 8-digit hexadecimal Frequency: 8-digit hexadecimal <b>Note</b> The data is refreshed during the Motion Control Module's I/O refresh period.
<ul style="list-style-type: none"> <li>• Select mode 1 or mode 2 in the System Setup.</li> <li>• Measurement starts when the Measurement Start Bit (A610.02 for high-speed counter 1 or A611.02 for high-speed counter 2) is turned ON.</li> <li>• The Measuring Flag (A608.06 for high-speed counter 1 or A609.06 for high-speed counter 2) will be ON during the measurement.</li> </ul>		

## 7-5-4 Pulse Input Specifications

Item	Specification			
Number of pulse inputs	2 inputs <b>Note</b> High-speed counter 1 can be an RS-422A line-driver input or an input with a voltage of 24 VDC. High-speed counter 2 can be an RS-422A line-driver input or an input with a voltage of 24 VDC, except for the FQM1-MMA21, which supports only line-driver inputs to high-speed counter 2.			
Signals	Encoder inputs A and B and pulse input Z			
Ports	High-speed counters 1 and 2		High-speed counters 1 and 2	
Input voltage	24 VDC $\pm 10\%$		RS-422A line-driver (AM26LS31 equivalent)	
	Phases A and B	Phase Z	Phases A and B	Phase Z
Input current	5 mA typical	8 mA typical	10 mA typical	13 mA typical
ON voltage	19.6 V DC min.	18.6 V DC min.	---	---
OFF voltage	4.0 V DC max.	4.0 V DC max.	---	---

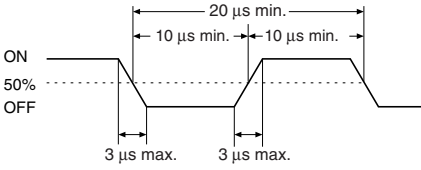
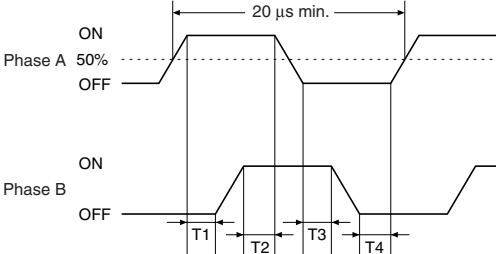
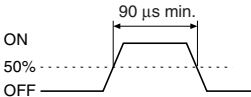
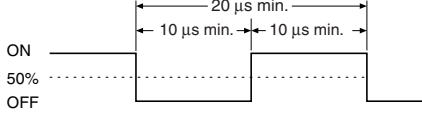
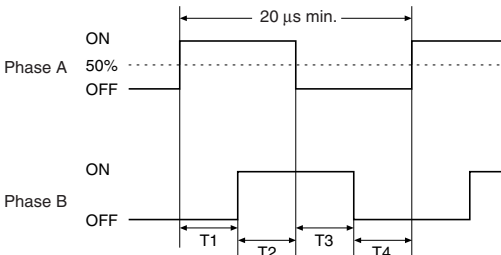
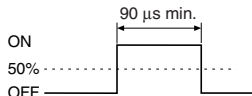
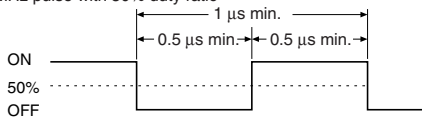
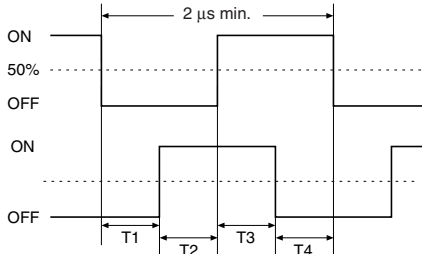
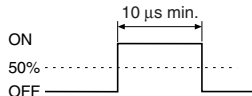

Item	Specification	
<p>Minimum response pulse</p> <p>At 50 kHz</p>	<p>Encoder Inputs A and B</p> <p>Waveform of Encoder Inputs A and B Signal rise and fall must be 3 <math>\mu</math>s max. 50-kHz pulse with 50% duty ratio</p>  <p>Relationship to Phase Differential Inputs A and B T1, T2, T3, and T4 must be 4.5 <math>\mu</math>s min. There must be 4.5 <math>\mu</math>s min. between phase-A and phase-B change points.</p>  <p>Encoder Input Z or Sensor Input Encoder Input Z Waveform The pulse width must be 90 <math>\mu</math>s min.</p> 	<p>Encoder Inputs A and B</p> <p>Encoder Inputs A and B Waveform Square waveform 50-kHz pulse with 50% duty ratio</p>  <p>Relationship to Phase Differential Inputs A and B T1, T2, T3, and T4 must be 4.5 <math>\mu</math>s min. There must be 4.5 <math>\mu</math>s min. between phase-A and phase-B change points.</p>  <p>Encoder Input Z or Sensor Input Encoder Input Z Waveform The pulse width must be 90 <math>\mu</math>s min.</p> 
<p>At 500 kHz</p>	<p>Operation may not be reliable above 50 kHz.</p>	<p>Encoder Inputs A and B</p> <p>Encoder Inputs A and B Waveform Square waveform 1-MHz pulse with 50% duty ratio</p>  <p>Relationship with Phase Differential Inputs A and B T1, T2, T3, and T4 must be 0.5 <math>\mu</math>s min. There must be 0.5 <math>\mu</math>s min. between phase-A and phase-B change points.</p>  <p>Encoder Input Z or Sensor Input Encoder Input Z Waveform The pulse width must be 10 <math>\mu</math>s min.</p> 

### 7-5-5 Latch Input Specifications

Item	Specification
Number of inputs	2
Input voltage	20.4 to 26.4 V
Input response	ON response: 30 μs OFF response: 200 μs

### 7-5-6 Applicable Instructions

Instruction	Control	Description
(@)CTBL(882)	Range comparison	One range comparison executed.
	Target value comparison table registration and starting comparison	Target value comparison table registered and comparison started.
	Target value comparison table registration	Target value comparison table registered.
(@)INI(880)	Starting comparison	Comparison started with previously registered target value comparison table.
	Stopping comparison	Target value comparison stopped.
	Changing PV	PV of high-speed counter changed.
	Changing circular value	Maximum circular value of high-speed counter changed.
(@)PRV(881)	Reading high-speed counter PV	PV of high-speed counter read.
	Reading high-speed counter movement or frequency	Movement or frequency of high-speed counter read.
	Reading the latched high-speed counter PV	Latched PV of high-speed counter read. (Reads the PV input to the latch register when the latch signal was input.)

### 7-5-7 Internal Circuit Configurations

#### Pulse Inputs

##### Phases A and B

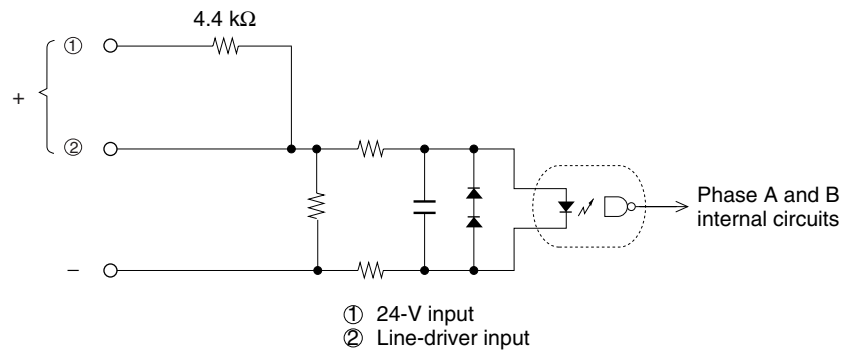

##### Phase Z

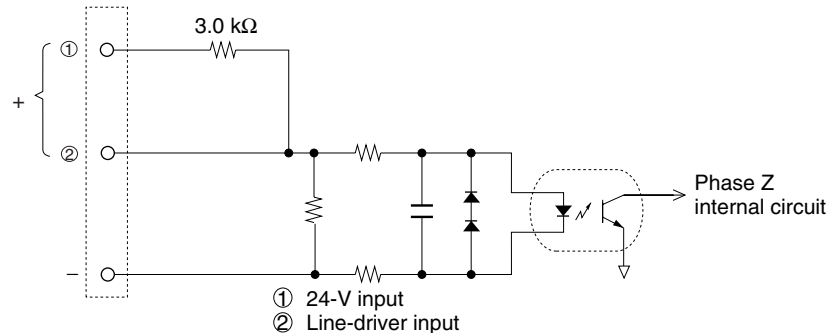

### 7-5-8 Pulse Input Function Description

The pulse input function uses the high-speed counters. The pulse input function can be used to monitor changes (movement) in the high-speed counter PV (mode 1) or changes in the high-speed counter frequency (mode 2).

#### High-speed Counter Function Description

##### Input Signal Type and Count Mode

High-speed counters 1 and 2 support the following inputs. The input method application depends on the signal type.

##### Phase Differential Inputs

This method uses the phase Z signal and the two phase signals (phase A and phase B) for a  $\times 1$ ,  $\times 2$ , or  $\times 4$  phase differential. The count is incremented or decremented according to the offset between the two phase signals.

##### Increment/Decrement Pulse Inputs

The phase-A signal is the UP pulse and the phase-B signal is the DOWN pulse. The count is incremented or decremented by these pulses.

##### Pulse + Direction Inputs

The phase-A signal is the pulse signal and the phase-B signal is the direction signal. The count is incremented or decremented based on the ON/OFF status of the phase-B signal.

#### ■ Phase Differential Input Operation

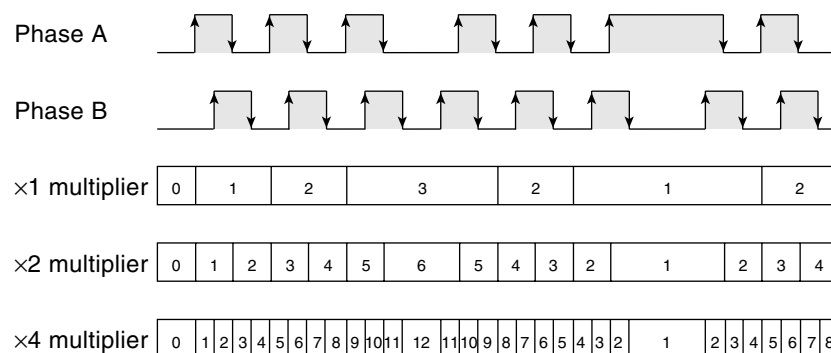

Phase A	Phase B	$\times 1$ multiplier	$\times 2$ multiplier	$\times 4$ multiplier
↑	L	Increment	Increment	Increment
H	↑	---	---	Increment
↓	H	---	Increment	Increment
L	↓	---	---	Increment
L	↑	---	---	Decrement
↑	H	---	Decrement	Decrement
H	↓	---	---	Decrement
↓	L	Decrement	Decrement	Decrement

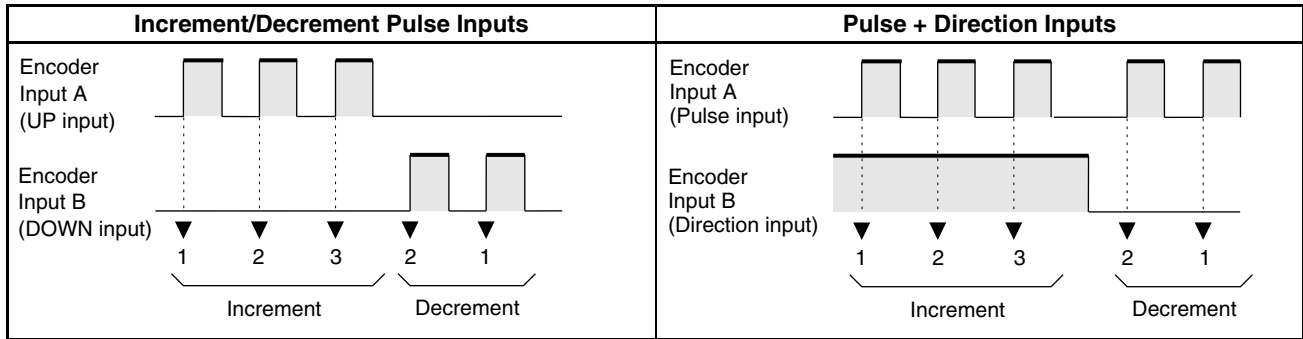

**Counter Operation (Numeric Ranges)**

The following two counter operations are available for high-speed counters 1 and 2, with the specified counting ranges.

**Circular Counter**

With a Circular Counter, the circular maximum count can be set in the System Setup, and when the count is incremented beyond this maximum value, it returns to zero. The count never becomes negative. Similarly, if the count is decremented from 0, it returns to the maximum value.

The number of points on the circular is determined by setting the maximum value (i.e., the circular maximum value), which can be set between 1 and FFFF FFFF hex.

**Linear Counter**

With a Linear Counter, the count range is always 8000 0000 to 7FFF FFFF hex. If the count decrements below 8000 0000 hex, an underflow is generated, and if it increments above 7FFF FFFF hex, an overflow is generated.

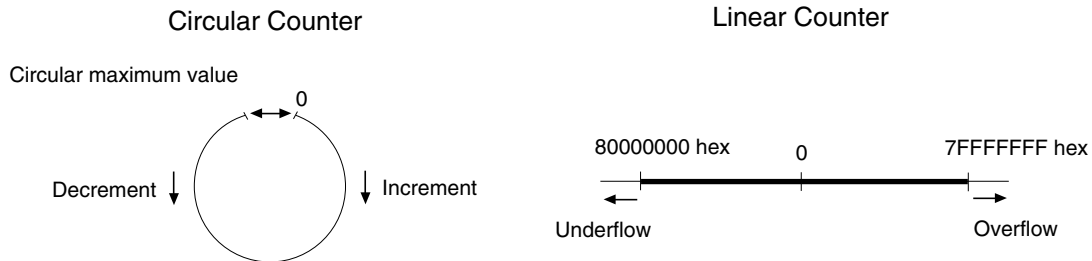

If an overflow occurs, the PV of the count will remain at 7FFF FFFF hex, and if an underflow occurs, it will remain at 8000 0000 hex. In either case, counting will stop and the PV Overflow/Underflow Flag shown below will turn ON to indicate the underflow or overflow.

- High-speed counter 1: A608.01
- High-speed counter 2: A609.01

**Note** The high-speed counter PVs are refreshed during the Motion Control Module's I/O refresh.

When restarting the counting operation, toggle (turn OFF and then ON) the corresponding counter's Reset Bit. (A610.01 is the Reset Bit for high-speed counter 1 and A611.01 is the Reset Bit for high-speed counter 2.)

**Reset Methods**

The following two methods can be set to determine the timing at which the PV of the counter is reset (i.e., set to 0):

- Phase-Z signal and software reset
- Software reset

**Phase-Z Signal (Reset Input) and Software Reset**

The PV of the high-speed counter is reset on the first rising edge of the phase-Z signal after the corresponding High-speed Counter Reset Bit (see below) turns ON.

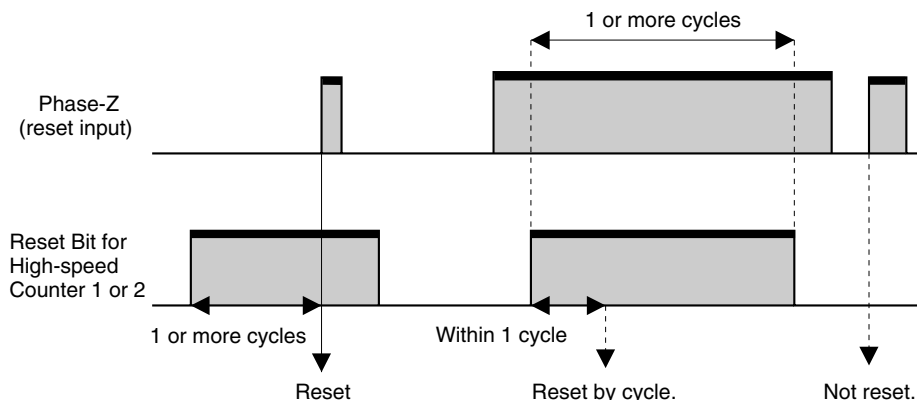

**Software Reset**

The PV is reset when the High-speed Counter Reset Bit turns ON. There are separate Reset Bits for high-speed counters 1 and 2.

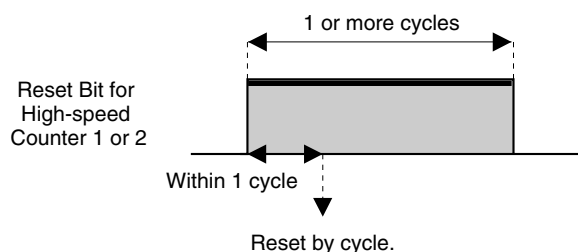

The High-speed Counter Reset Bits are as follows:

- High-speed Counter 1 Reset Bit: A610.01
- High-speed Counter 2 Reset Bit: A611.01

The High-speed Counter Reset Bits are refreshed only once each cycle, so a Reset Bit must be ON for a minimum of 1 cycle to be read reliably.

**Note** The comparison table registration and comparison execution status will not be changed even if the PV is reset. If a comparison was being executed before the reset, it will continue.

**Checking for High-speed Counter Interrupts**

The following two methods are available to check the PV of high-speed counters 1 or 2.

- Target-value comparison method
- Range comparison method

**Target-value Comparison Method**

Up to 48 target values and corresponding interrupt task numbers can be registered in the comparison table. When the counter PV matches one of the 48 registered target values, the specified interrupt task will be executed.

Comparisons are made to each target value in the order that they appear in the comparison table until all values have been met, and then comparison will return to the first value in the table.

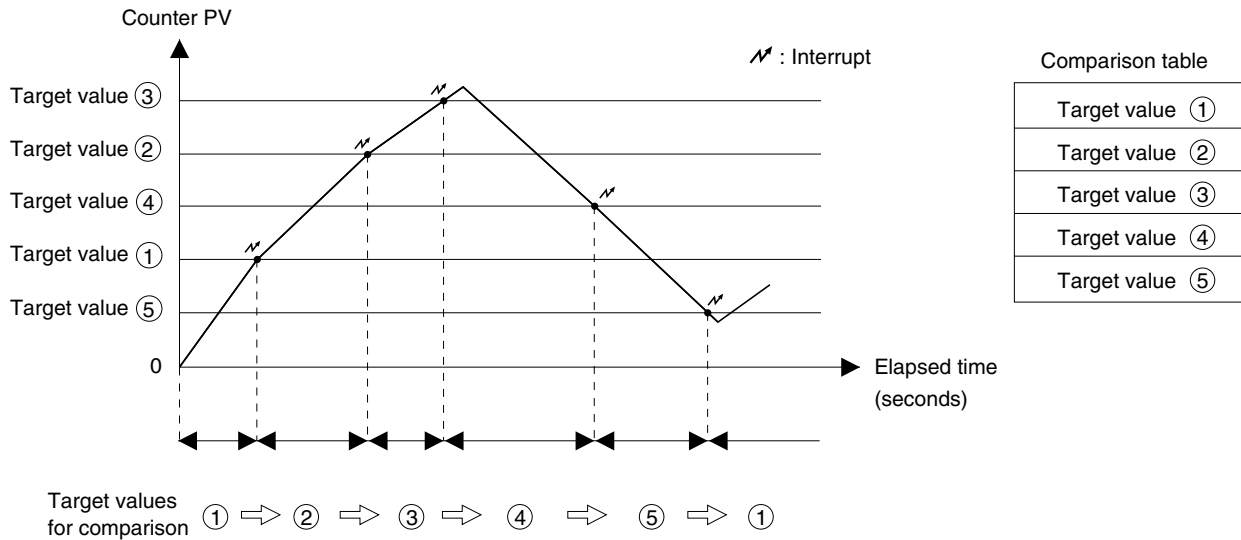

**Range Comparison Method**

Up to 16 comparison ranges (lower and upper limit values) and corresponding output bit patterns can be registered in the comparison table. When the PV of the counter first is within the upper and lower limits of one of the ranges for CTBL(882) execution, the corresponding bit pattern (1 to 16) will be output to A613 or A615.

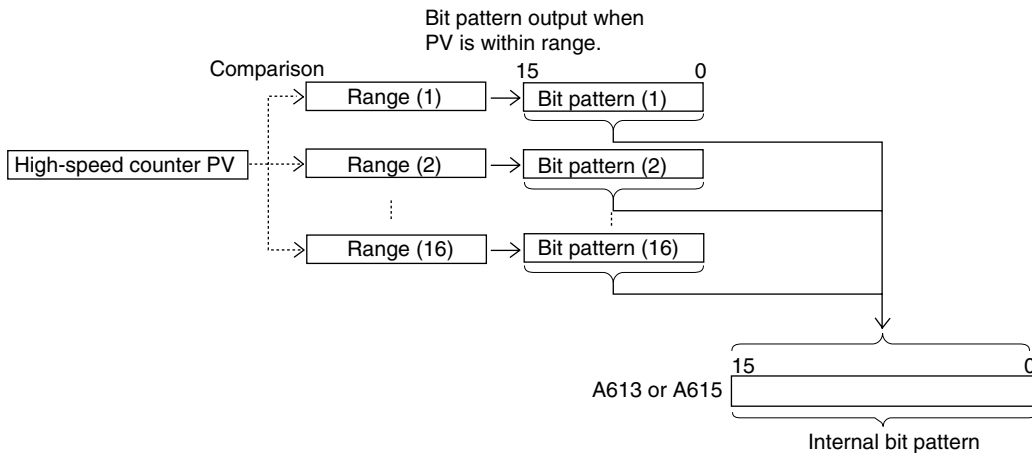
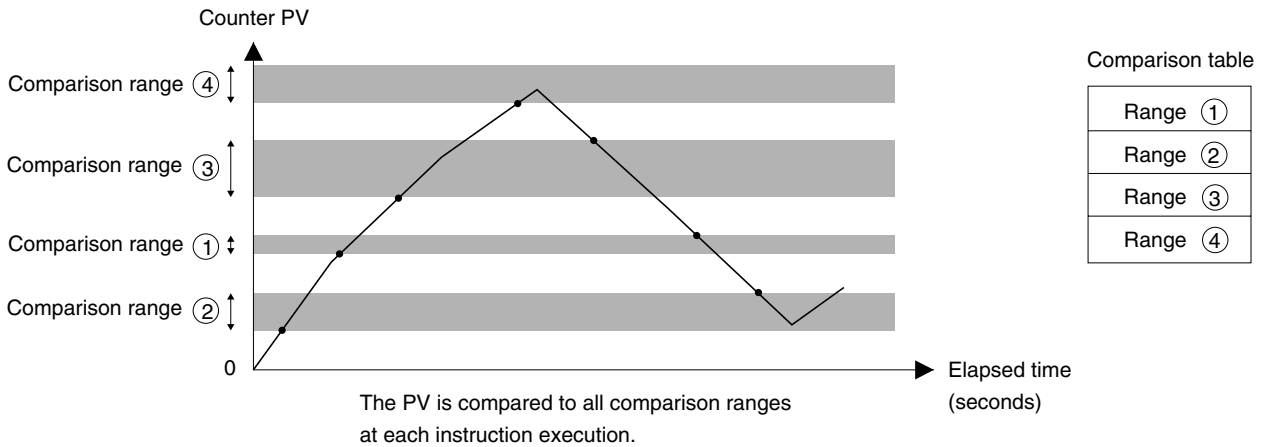

**Monitoring High-speed Counter Movement (Mode 1)**

This function monitors the change in a high-speed counter's PV (travel distance) regularly at the preset sampling period. The sampling period can be set between 1 and 9,999 ms.

If the sampling time is set to 0, the change will be sampled once each cycle. The change in the high-speed counter PV (travel distance) is stored in A604 and A605 (high-speed counter 1) or A606 and A607 (high-speed counter 2). Status Flags A608.06 and A609.06 can be checked to determine whether or not change is being measured.

- Note**
- (1) The change (per sampling period) is refreshed during the Motion Control Module's I/O refreshing.
  - (2) The change in the high-speed counter PV's is output as an absolute value.

Word	Bits	Function	Details
A604 and A605	00 to 15	High-speed Counter 1 Monitor Data	Contains the change in high-speed counter 1. The change in the high-speed counter PV during the specified sampling period is stored in 8-digit hexadecimal (0000 0000 to FFFF FFFF).
A606 and A607	00 to 15	High-speed Counter 2 Monitor Data	Contains the change in high-speed counter 2. The change in the high-speed counter PV during the specified sampling period is stored in 8-digit hexadecimal (0000 0000 to FFFF FFFF).
A608	06	High-speed Counter 1 Status Flag	Measuring Flag OFF: The high-speed counter movement measurement operation is stopped. ON: The high-speed counter movement is being measured.
A609	06	High-speed Counter 2 Status Flag	Measuring Flag OFF: The high-speed counter movement measurement operation is stopped. ON: The high-speed counter movement is being measured.

The pulse input's counter data display must be set to counter movements (mode 1) in the System Setup in advance. The sampling period must also be set in the System Setup.

Tab page	Function		Details
Pulse input	Counter 1	Counter data display	1 hex: Counter movements (mode 1)
		Sampling time (mode 1)	Set the sampling time when measuring counter movement. 0000: Cycle time 0001 to 270F hex: 1 to 9999 ms (unit: 1 ms)
	Counter 2	Counter data display	1 hex: Counter movements (mode 1)
		Sampling time (mode 1)	Set the sampling time when measuring counter movement. 0000: Cycle time 0001 to 270F hex: 1 to 9999 ms (unit: 1 ms)

**High-speed Counter Movement (Mode 1) Specifications**

Item	Specifications
Applicable pulse input	Either pulse 1 (high-speed counter 1) or pulse 2 (high-speed counter 2) can be used.
Displayable movement	0000 0000 to FFFF FFFF <b>Note</b> The software can generate the range of values shown above, but some hardware may not be able to display the full range due to input limitations.
Sampling time	Can be set to the cycle time or a fixed time between 1 and 9,999 ms.
Operating conditions	In the System Setup, set the pulse input's counter data display to counter movements (mode 1) and specify the sampling time.

- Note**
- (1) When using mode 1 with a circular counter, set the maximum circular value to 10 or higher.
  - (2) In mode 1, the Motion Control Module outputs the change as the difference in the count measured each sampling period. The output change varies, so determine how to manage the output value in the user program when the counter is reset or the INI(880) instruction is executed to change the PV during sampling.

**Monitoring a High-speed Counter's Frequency (Mode 2)**

Mode 2 is supported by high-speed counter 1 only.

This function monitors the input pulse's frequency from the high-speed counter movement value. The frequency is stored in A604 and A605. Status Flag A608.06 can be checked to determine whether or not the frequency is being measured.

- Note**
- (1) The frequency value stored in the Auxiliary Area is refreshed during the Motion Control Module's I/O refreshing.
  - (2) The frequency measurement can be performed only with high-speed counter 1. The frequency cannot be measured with high-speed counter 2.
  - (3) When measurement is started, the measurement direction (A610.03) must be specified to match the direction of the input pulses being measured.

Word	Bits	Function	Details
A604 and A605	00 to 15	High-speed Counter 1 Monitor Data	Contains the frequency measurement. The frequency calculated from the high-speed counter PV is stored in 8-digit hexadecimal (0000 0000 to 0007 A120 hex = 0 to 500 kHz).
A608	06	High-speed Counter 1 Status Flag	Measuring Flag OFF: The high-speed counter frequency measurement operation is stopped. ON: The high-speed counter frequency is being measured.

The pulse input's counter data display must be set to frequency measurement (mode 2) in the System Setup in advance.

System Setup	Function	Details
Pulse Input Tab Page Counter data display	Specifies the counter 1 measurement mode.	2 hex: Frequency (mode 2)



**Frequency Measurement (Mode 2) Specifications**

Item	Specifications
Applicable pulse input	Only pulse 1 (high-speed counter 1) can be used.
Measurable frequencies	0 to 500 kHz <b>Note</b> When no pulses have been input for 10 s, the measured value is set to 0 Hz (stopped). The previous output value is retained during this 10-second interval.
Measurement period	5 ms max. (input frequency 500 Hz min.) <b>Note</b> At input frequencies below 500 Hz, the measurement period is increased to accommodate the lower input frequencies and becomes 200 ms max. for input frequencies of 10 Hz min.
Operating conditions	In the System Setup, set the pulse input's counter data display to frequency measurement (mode 2).

**Latching a High-speed Counter's PV**

The present counter value can be latched at the rising edge of the latch signal input and stored as the latch register value. Each time the counter value is captured, the latch register value is overwritten with the new value and the old value is lost.

To use the latched counter value (latch register value) in the ladder program, read the latch register value with the PRV(881) instruction.

Word	Bit	Function	Details
A608	08	High-speed Counter 1 Status Flag	Count Latched Flag Indicates that a high-speed counter PV has been captured in the latch register by the latch signal input.
A609	08	High-speed Counter 2 Status Flag	Count Latched Flag (This flag has the same function as the flag for high-speed counter 1.)
A610	08	High-speed Counter 1 Command	Latch Input 1 Enable OFF: Disabled ON: Enabled
	09		Latch Input 2 Enable OFF: Disabled ON: Enabled
A611	08	High-speed Counter 2 Command	Latch Input 1 Enable OFF: Disabled ON: Enabled
	09		Latch Input 2 Enable OFF: Disabled ON: Enabled

There is one latch register provided for each counter.

Both latch input 1 and latch input 2 can be enabled for a single counter, but only latch input 1 will be effective when both inputs are enabled.

Two latch inputs can be used for a single counter by enabling/disabling latch input 1 and 2 from the ladder program to enable only the desired input when it is required. In this case, allow at least one Motion Control Module cycle between the use of the two inputs.

## 7-5-9 Pulse Input Function Procedures

### High-speed Counter Procedure

- 1,2,3...**
1. Determine the Input Mode, reset method, and Numeric Range.
    - Counting Speed: 50 kHz or 500 kHz
    - Input Mode: Phase Differential, Increment/Decrement, or Pulse + Direction
    - Reset method: Phase Z and software reset, or Software reset
    - Counter Operation: Circular Counter or Linear Counter
  2. Wire the input.
  3. Make the necessary System Setup settings.
    - Counting Speed: 50 kHz or 500 kHz
    - Input Mode: Phase Differential, Increment/Decrement, or Pulse + Direction
    - Reset: Phase Z and software reset, or Software reset
    - Counter Operation: Circular Counter or Linear Counter
    - Count Check Method: Target-value Comparison or Range Comparison
  4. If the count check is being used, determine the count check (comparison) method.
  5. Create the necessary ladder programming.
    - Turn ON the High-speed Counter 1 or 2 Start Bit (A610.00 or A611.00) and start the high-speed counter.
    - CTBL(882) instruction: Specifies the port, registers the comparison table, and starts comparison.
    - INI(880) instruction: Specifies the port, changes the PV, and starts comparison.
    - PRV(881) instruction: Specifies the port and reads the high-speed counter PV.

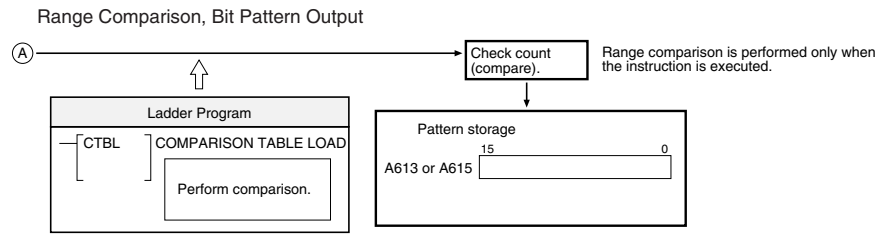
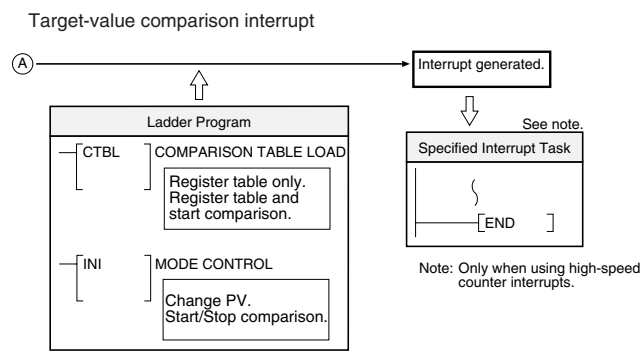
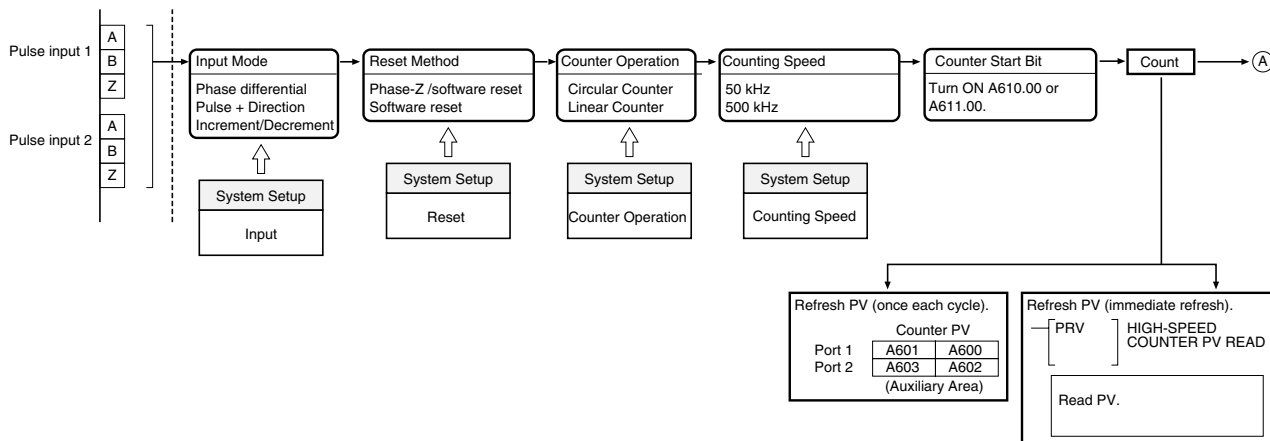

**Mode 1 Procedure**

- 1,2,3... 1. Determine the Counting Speed, Input Mode, Reset Method, and Counter Operation.
  - Counting Speed: 50 kHz or 500 kHz
  - Input Mode: Phase Differential, Increment/Decrement, or Pulse + Direction
  - Reset method: Phase Z and software reset, or Software reset
  - Counter Operation: Circular Counter or Linear Counter
2. Wire the input.
3. Make the necessary System Setup settings.
  - Counter Data Display: Counter movements (mode 1)
4. Create the necessary ladder programming.
  - Turn ON the High-speed Counter 1 or 2 Start Bit (A610.00 or A611.00) and start the high-speed counter.
  - Turn ON the Measurement Start Bit (A610.02 or A611.02).

- Monitor the high-speed counter movement value in A604 and A605 (high-speed counter 1) or A606 and A607 (high-speed counter 2).

**Procedure**

- 1,2,3...**
1. Set *Counter movements (mode 1)* in the System Settings (*Pulse Input, Counter data display*).
  2. Turn ON the Measurement Start Bit (A610.02 or A611.02).
  3. Monitor the high-speed counter movement value in A604 and A605 (high-speed counter 1) or A606 and A607 (high-speed counter 2).

**Mode 2 Procedure**

- 1,2,3...**
1. Determine the Counting Speed, Input Mode, Reset Method, and Counter Operation.
    - Counting Speed: 50 kHz or 500 kHz
    - Input Mode: Phase Differential, Increment/Decrement, or Pulse + Direction
    - Reset method: Phase Z and software reset, or Software reset
    - Counter Operation: Circular Counter or Linear Counter
  2. Wire the input.
  3. Make the necessary System Setup settings.
    - Counter Data Display: Frequency measurement (mode 2)
  4. Create the necessary ladder programming.
    - Turn ON the High-speed Counter 1 Start Bit (A610.00) and start the high-speed counter.
    - Specify the rotation direction in the Measurement Direction Bit (A610.03). OFF is forward, ON is reverse.
    - Turn ON the Measurement Start Bit (A610.02).
    - Monitor the high-speed counter's frequency in A604 and A605.

**Procedure**

- 1,2,3...**
1. Set *Frequency measurement (mode 2)* in the System Settings (*Pulse Input, Counter data display*).
  2. Specify the rotation direction in the Measurement Direction Bit (A610.03).
  3. Turn ON the Measurement Start Bit (A610.02).
  4. Monitor the high-speed counter's frequency in A604 and A605.

**7-5-10 Pulse Input Function Example Application**

**Example 1:**  
**High-speed Counter**  
**Target Value**  
**Comparison Interrupt**

In this example, pulse input 1 operates a high-speed counter, the high-speed counter PV is compared in a target-value comparison, and corresponding interrupt tasks are executed when the target values are reached.

The Reset Bit is kept ON in the program and the PV of the counter is reset when the phase-Z signal is turned ON after the PV reaches its maximum value. Before running the program, make the following settings in the System Setup and restart the FQM1 to enable the new settings.

Counter 1:

Linear Counter, Counting speed = 50 kHz, Phase Z and software reset, and Increment/decrement pulse input

**Example**

When the PV reaches 2,500 hex, interrupt task 10 is started.  
When the PV reaches 7,500 hex, interrupt task 11 is started.  
When the PV reaches 10,000 hex, interrupt task 12 is started.

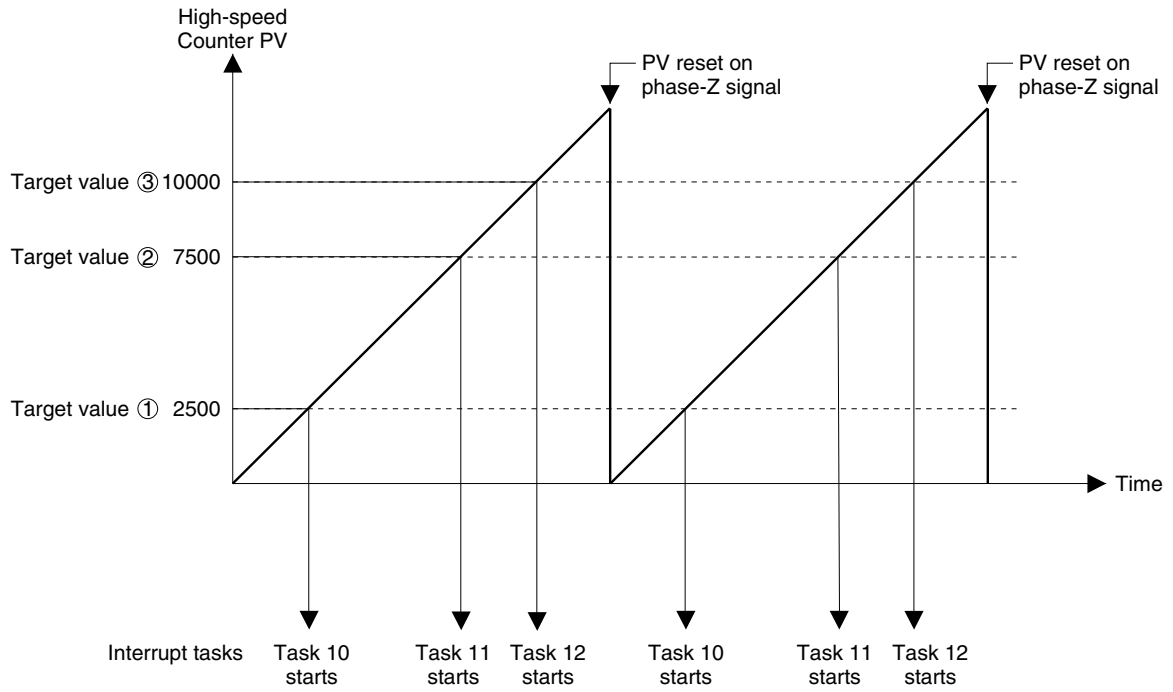

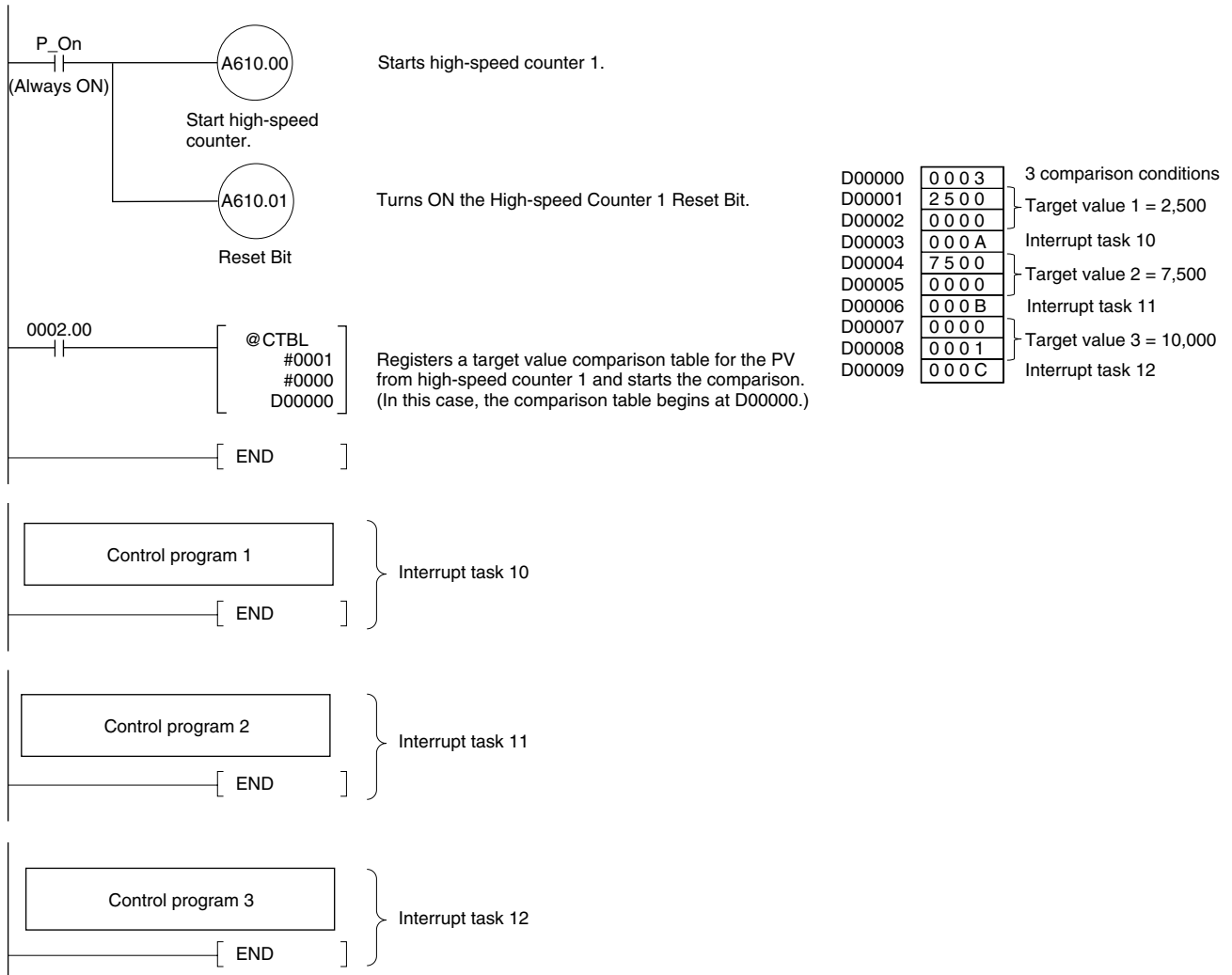

**Example 2:**  
**High-speed Counter**  
**Range Comparison &**  
**Bit Pattern Output**

In this example, pulse input 1 operates a high-speed counter, the high-speed counter PV is compared in a range comparison, and corresponding bit pattern is output internally when the PV is within a specified range. The internal bit pattern value is output by a transfer to CIO 0001.

The Reset Bit is kept ON in the program and the counter PV is reset when the phase-Z signal turns ON after the PV reaches its maximum value. Before running the program, make the following settings in the System Setup and restart the FQM1 to enable the new settings.

Counter 1:

Linear counter, Counting speed = 50 kHz, Phase Z and software reset, and Increment/decrement pulse input

The other System Setup settings are left at their default settings.

**Example**

When the PV is between 0 and 2,500 hex, CIO 0001.00 is ON.  
 When the PV is between 2,501 and 7,500 hex, CIO 0001.01 is ON.  
 When the PV is between 7,501 and 10,000 hex, CIO 0001.02 is ON.  
 When the PV is 10,001 hex or higher, CIO 0001.03 is ON.

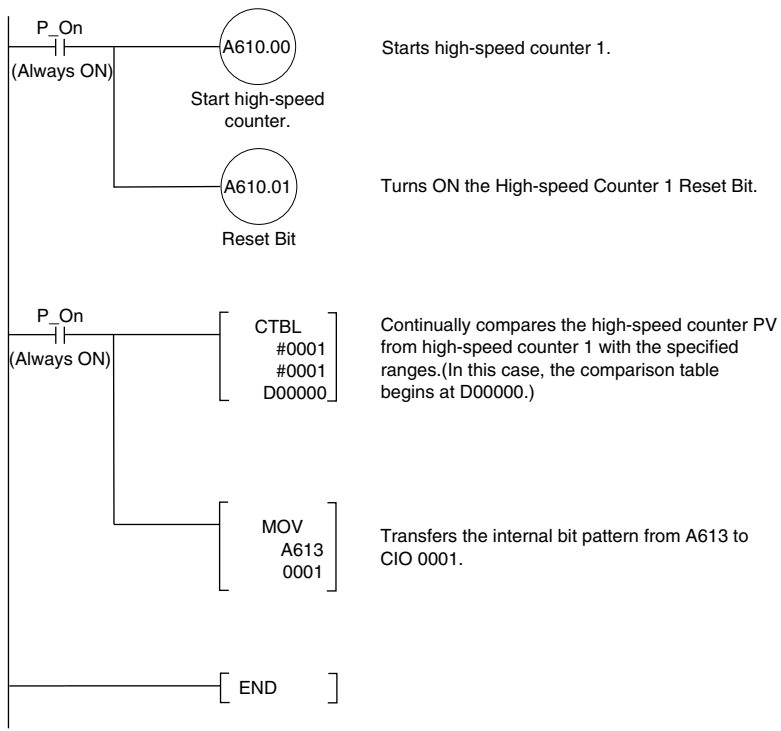
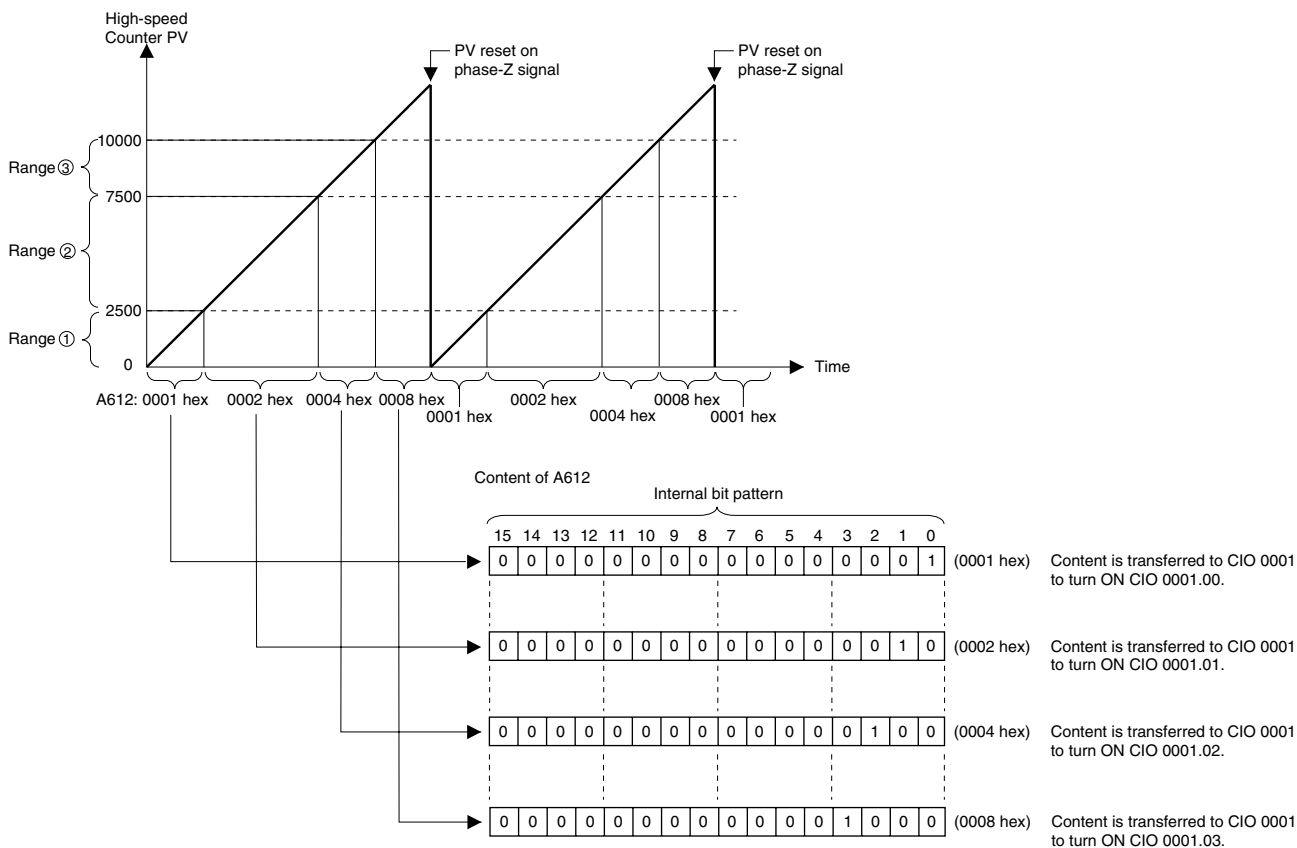

Starts high-speed counter 1.

Turns ON the High-speed Counter 1 Reset Bit.

Continually compares the high-speed counter PV from high-speed counter 1 with the specified ranges. (In this case, the comparison table begins at D00000.)

Transfers the internal bit pattern from A613 to CIO 0001.

D00000	0 0 0 4	4 comparison conditions	
D00001	0 0 0 0	Lower limit ① 0	Range ①
D00002	0 0 0 0	Upper limit ① 2500	
D00003	2 5 0 0	Lower limit ② 2501	Range ②
D00004	0 0 0 0	Upper limit ② 7500	
D00005	0 0 0 1	Bit pattern	
D00006	2 5 0 1	Lower limit ③ 7501	Range ③
D00007	0 0 0 0	Upper limit ③ 10000	
D00008	7 5 0 0	Lower limit ④ 10001	Range ④
D00009	0 0 0 0	Upper limit ④ 7FFFFFFF	
D00010	0 0 0 2	Bit pattern	
D00011	7 5 0 1	Lower limit ④ 10001	Range ④
D00012	0 0 0 0	Upper limit ④ 7FFFFFFF	
D00013	0 0 0 0	Bit pattern	
D00014	0 0 0 1	Lower limit ④ 10001	Range ④
D00015	0 0 0 4	Upper limit ④ 7FFFFFFF	
D00016	0 0 0 1	Bit pattern	
D00017	0 0 0 1	Lower limit ④ 10001	Range ④
D00018	F F F F	Upper limit ④ 7FFFFFFF	
D00019	7 F F F	Bit pattern	
D00020	0 0 0 8	Bit pattern	

**Example 3:  
Latching High-speed  
Counter PV**

In this example, pulse input 1 operates a high-speed counter, the high-speed counter PV is latched, and the captured high-speed counter PV is read. When the Latch Input 1 Enable Bit is ON and the latch input 1 is turned OFF→ON externally, the high-speed counter PV is captured to the latch register and the Count Latched Flag is turned ON during the next I/O refreshing.

The Count Latched Flag is used as a trigger for the PRV(881) instruction to read the captured high-speed counter PV and the Count Latched Flag is then turned OFF.

If latch input 1 is turned ON again while the Count Latched Flag is still ON (before the captured PV has been read by the PRV(881) instruction), the old captured PV will be refreshed with the new captured PV.

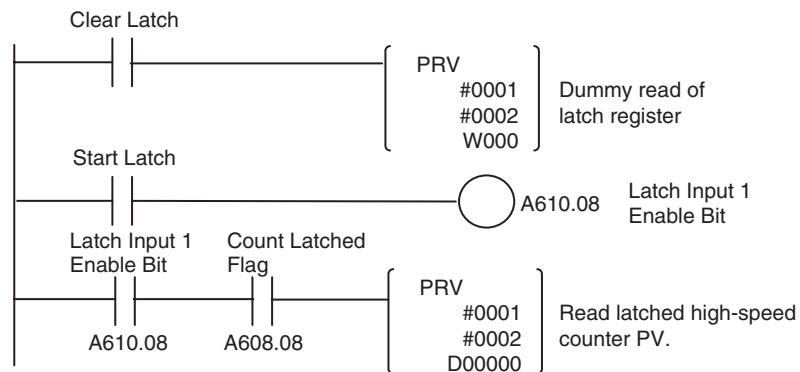
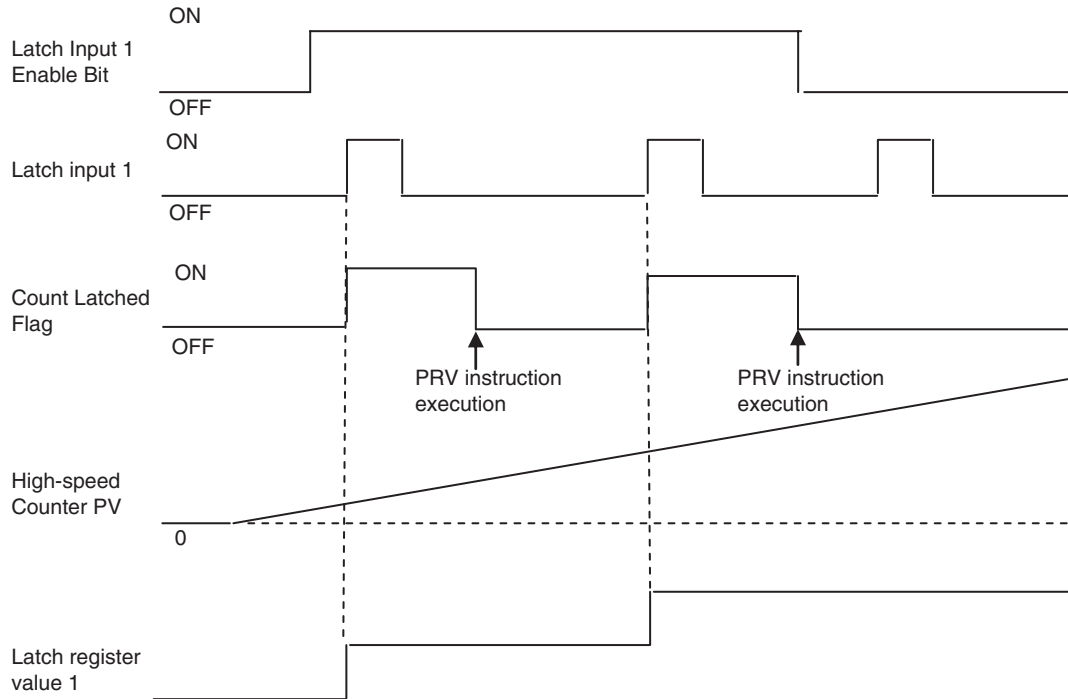



## 7-6 Pulse Outputs

### 7-6-1 Applicable Models

Model	Functions
FQM1-MMP21	Motion Control Module with Pulse I/O

### 7-6-2 Outline

The FQM1-MMP21 Motion Control Module provides 2 pulse outputs. The pulse outputs can be used for the following functions.

**Note** Set the pulse output operation mode for each output in System Setup (Pulse Output Tab Page).

Function	Description	Processing for PV
Pulse output operation mode	The pulse outputs can be used for positioning or speed control at a fixed duty ratio. Select one of five pulse output operation modes: Relative pulse output, linear absolute pulse output, circular absolute pulse output, electronic cam (linear), and electronic cam (circular).	It is possible to generate target-value interrupts (see note 2) or range-comparison bit pattern outputs based on the pulse output's PV. (See note 1.)
One-shot pulse outputs	Pulse output turned ON for only the specified interval (0.01 to 9,999 ms.)	None
Calculation (time measurement)	Enables use of the pulse output counter as a timer using the one-shot pulse output timer. <b>Note</b> Pulses are not output for this mode and the specified port cannot be used for pulse output.	It is possible to generate target-value interrupts or range-comparison bit pattern outputs based on the pulse counter's PV. (See note 1.)

**Note** (1) The processes listed in the following table can be performed for the PV of a pulse output, pulse output counter timer, or one-shot pulse output elapsed time.

Process	Description
Target value interrupts	An interrupt task can be executed when the high-speed counter PV equals a target value.
Bit pattern outputs for range comparisons	A user-set bit pattern is output internally when the high-speed counter PV is within a specified range.

(2) Cannot be combined with pulse output in independent mode.

### 7-6-3 Specifications

Item	Specification			
Acceleration/ deceleration	None		Yes	
Trapezoid	None		None (acceleration or deceleration)	Yes with separate acceleration and deceleration rates
Instructions for independent-mode positioning	PULS(886) + SPED(885)	PULS(886) (Electronic Cam Control)	PULS(886) + ACC(888)	PLS2(887)
Instructions for continuous-mode speed control	SPED(885)	---	ACC(888)	---
Output frequencies	Constant specified for SPED(885): 0 Hz to 1 MHz Word specified for SPED(885): 0 Hz to 1 MHz	0 Hz to 1 MHz	0 Hz to 1 MHz	
<p>Although the above ranges can be set for the instructions, the output frequency range is ultimately controlled by the clock frequency. The output frequencies are obtained by dividing the clock pulse with an integer dividing ratio, meaning the actual output frequency can be different from the set frequency. (Refer to <i>Precautions when Using Pulse Outputs</i> on page 175 for details.)</p> <p>The settings in the System Setup (Clock) are as follows:</p> <p>20 MHz Pulse output frequency range: 400 Hz to 1 MHz            10 MHz Pulse output frequency range: 200 Hz to 200 kHz            5 MHz Pulse output frequency range: 100 Hz to 100 kHz            2.5 MHz Pulse output frequency range: 40 Hz to 50 kHz            1.25 MHz Pulse output frequency range: 20 Hz to 20 kHz</p>				
Frequency acceleration/deceleration rate	---		1 Hz to 9,999 Hz every 2 ms or 1 ms	
Duty ratio	50% (fixed)			
Pulse output operation modes	<p>One of the following can be set for each port in the System Setup.</p> <ol style="list-style-type: none"> <li>1) Relative pulse output: No. of output pulses = pulse output value</li> <li>2) Absolute linear pulse output: No. of output pulses =  PV of pulse output – target pulse amount </li> <li>3) Absolute circular pulse output: As above. If the circular maximum count is exceeded, the count value returns to 0000 0000 hex. (Circular maximum count is set in System Setup.)</li> <li>4) Electronic cam control (linear) (output with absolute position specification): The direction is automatically determined from the relation between the PV and target position (PV &lt; Target = CW, PV &gt; Target = CCW. No. of output pulses =  PV of pulse output – target pulse amount )</li> <li>5) One-shot pulse output: Pulse turned ON for specified time between 0.01 and 9,999 ms via STIM(980) instruction</li> <li>6) Pulse counter timer: High-precision timer created using the one-shot pulse output function. Pulses are not output externally.</li> <li>7) Electronic cam (circular) (output with absolute position specification): The direction is automatically determined from the relation between the PV and target position (PV &lt; Target = CW, PV &gt; Target = CCW). No. of output pulses =  PV of pulse output – target pulse amount )</li> </ol>			

Item	Specification
Number of output pulses	1) Relative pulse output: 0000 0000 to FFFF FFFF hex 2) Absolute linear pulse output: 8000 0000 to 7FFF FFFF hex 3) Absolute circular pulse output: 0000 0000 to Circular maximum count hex 4) Electronic cam control (linear) (output with absolute position specification): 8000 0000 to 7FFF FFFF hex 5) Electronic cam control (circular) (output with absolute position specification): 0000 0000 to 7FFF FFFF hex  <b>Note</b> The number of pulses is not set for a one-shot pulse output or pulse counter timer.
Storage location for pulse output PV	The PVs for pulse output operation modes 1 to 5, listed above, are stored in 8-digit hexadecimal in the following Auxiliary Area words: Pulse output 1: A621 (upper bytes) and A620 (lower bytes) Pulse output 2: A623 (upper bytes) and A622 (lower bytes)  Target value comparison interrupts or bit pattern outputs for range comparisons can be performed on the PV.  <b>Note</b> The contents of these above words are updated during I/O refreshing.

### 7-6-4 Pulse Output Specifications

#### All Pulse Outputs Except for One-shot Pulse Outputs

Item	Specification
Number of pulse outputs	2 outputs
Signals	Pulse output CW and CCW
Max. output frequency	1 MHz (but actual output frequencies are governed by clock frequency setting)
External power supply	5 VDC +10%/–15%, 120 mA max.
Line-driver output	Conforms to Am26LS31 and max. output current is 20 mA.

#### One-shot Pulse Outputs

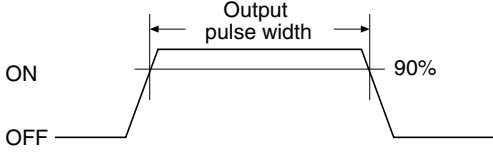
Item	Specification
Number of pulse outputs	2 output
External power supply	24 VDC +10%/–15%, 30 mA max.
Max. switching capacity	NPN open-collector, 80 mA at 5 to 24 VDC ±10%
Min. switching capacity	NPN open-collector, 7 mA at 5 to 24 VDC ±10%
Leakage current	0.1 mA max.
Residual voltage	0.4 V max.
Output pulse width	(Set time) ± (1 μs or 0.1% of the set time, whichever is larger)  
	<b>Note</b> 1. The load during measurement is assumed to be a simple resistive load and the impedance of the cable connecting the load is not considered. 2. The actual pulse width might be smaller than the value given above due to pulse waveform distortion caused by impedance in the connecting cables.

### 7-6-5 Applicable Instructions

The following seven instructions can be used to control pulse outputs. The relationship between the instruction and the types of pulse output that is possible is also listed in the following table.

Instruction	Control	Positioning (Independent Mode)			Speed Control (Continuous Mode)	
		No acceleration/deceleration, single-phase output	Acceleration/deceleration, single-phase output		No acceleration/deceleration, single-phase output	Acceleration/deceleration, single-phase output
			No trapezoid, acceleration and deceleration	Trapezoid, separate acceleration and deceleration rates		
PULS(886)	Sets number of output pulses or absolute position.	OK	OK	No	No	No
SPED(885)	Controls pulse output without acceleration or deceleration (number of pulses set with PULS(886) for positioning).	OK	No	No	OK	No
ACC(888)	Controls pulse output with same acceleration and deceleration without trapezoid (number of pulses set with PULS(886) for positioning).	No	OK	No	No	OK
PULS(886) for Electronic Cam	Sets absolute position or frequency and outputs pulses.	OK	No	No	No	No
PLS2(887)	Controls pulse output with different acceleration and deceleration with trapezoid (number of pulses is also set using PLS2(887)).	No	No	OK	No	No
INI(880)	Stops pulse output.	OK	OK	OK	OK	OK
PRV(881)	Reads the current PV for pulse output.	OK	OK	OK	OK	OK

#### Instructions Ineffective during Pulse Output

Once pulse output has been started by an instruction, the output cannot always be changed with an instruction. Refer to *7-6-15 Pulse Output Starting Conditions* for details on the allowed combinations of pulse output instructions.

## 7-6-6 Pulse Output Function Details

### Overview

Pulses are output in independent mode or continuous mode. In independent mode, the number of output pulses is specified in advance. In continuous mode, the number of output pulses is not specified in advance.

Mode	Description
Independent mode	This mode is used for positioning. The pulse output stops automatically after the specified number of pulses has been output. With some instructions, the pulse output can be stopped (see note).
Continuous mode	This mode is used for speed control. The pulse output continues until it is stopped by an instruction (see note) or the Motion Control Module is switched to PROGRAM mode.

**Note** When pulses are being output by an SPED(885) or ACC(888) instruction, the pulse output can be stopped by executing the INI(880) instruction. The pulse output can also be stopped by executing SPED(885) or ACC(888) with a target frequency = 0.

When pulses are being output by the PULS(886) instruction (Electronic Cam Control), the pulse output can be stopped by executing the INI(880) instruction.

When using independent mode, select one of the four pulse output operation modes shown in the following table, depending on the method used to calculate the number of pulses and whether it is necessary to change the value during operation. Specify the pulse output operation mode in the System Setup (the operation mode setting in the Pulse Output Tab Page). In addition, if the PULS(886) instruction is being used, it is necessary to specify the Pulse Type in the second operand.

Pulse output operation mode (Only in Independent Mode)	Description	Compatible instructions
(1) Relative pulse output	Positions to a relative position from the present position. The number of output pulses (actual output amount) in the specified direction is the target number of pulses. <ul style="list-style-type: none"> <li>• The frequency can be changed during pulse output.</li> <li>• The direction and the target number of pulses <b>cannot</b> be changed during pulse output.</li> </ul>	PULS(886) + SPED(885) or PULS(886) + ACC(888) (PULS(886) sets the number of pulses and SPED(885) or ACC(888) starts the pulse output.) PLS2(887) (Sets number of pulses and starts pulse output.)
(2) (3) Absolute pulse output	Positions to an absolute position from the origin. The number of output pulses is calculated automatically from the difference between the present position (pulse output PV) and target pulse amount. $\text{Number of output pulses (actual output amount)} =  \text{Present position} - \text{Target position} $ <ul style="list-style-type: none"> <li>• The frequency can be changed during pulse output.</li> <li>• The direction and the target number of pulses <b>cannot</b> be changed during pulse output.</li> </ul>	---
(2) Linear mode	Operates as linear counter with pulse output values ranging from 8000 0000 to 7FFF FFFF hex.	Same as for (1).
(3) Circular mode	Operates as circular counter with pulse output values ranging from 0000 0000 to the circular value. <p>When the pulse output PV exceeds the circular value, it is automatically returned to 0000 0000. Conversely, when the pulse output PV is decremented from 0000 0000, it is automatically returned to the circular value.</p>	PULS(886) + SPED(885) or PULS(886) + ACC(888) (PULS(886) sets the number of pulses and SPED(885) or ACC(888) starts the pulse output.)
(4) Electronic cam control (linear) (5) Electronic cam control (circular)	Positions to an absolute position from the origin. The difference between the present position (pulse output PV) and target pulse amount is calculated automatically. $\text{Number of output pulses (actual output quantity)} =  \text{Present pulse position} - \text{Target position} $ <ul style="list-style-type: none"> <li>• The direction is recognized automatically (CW direction when the present position &lt; target position, and CCW direction when the present position &gt; target position).</li> <li>• The frequency and target position can be changed during pulse output. The pulse output will stop if the direction is changed during pulse output.</li> </ul>	PULS(886) (Sets the number of pulses and starts the pulse output.) ACC(888) PLS2(887)

**Pulse Output Operations**

The following table shows the operations that can be performed with the pulse output function.

Mode	Frequency changes	Description	Procedure		Example
			Instruc-tions	Settings	
Continu-ous mode (Speed control)		The frequency is changed in steps (up or down) during pulse output.	SPED(885) ↓ SPED(885)	Port, CW/CCW, Continuous, Target frequency	Use when changing frequency in steps. (See page 190.)
		The frequency is accelerated or decelerated from the present frequency at a fixed rate.	ACC(888) or SPED(885) ↓ ACC(888)	Port, CW/CCW, Continuous, Acceleration/deceleration rate, Target frequency	Use when accelerating frequency at a fixed rate. (See page 190.)

Mode	Frequency changes	Description	Procedure		Example
			Instruc-tions	Settings	
Independent mode (Positioning)		<p>Pulse output starts at the specified frequency and stops when the specified number of pulses have been output. (The number of pulses cannot be changed during pulse output.)</p>	<p>PULS(886) ↓ SPED(885)</p>	<p>No. of pulses, Relative or absolute operation, Port, CW/CCW, Independent, Target frequency</p>	<p>Use when positioning with a single-phase output and no acceleration or deceleration. (See page 189.)</p>
		<p>The frequency accelerates or decelerates at a fixed rate and stops immediately when the specified number of pulses have been output. (The number of pulses cannot be changed during pulse output.)</p>	<p>PULS(886) ↓ ACC(888)</p>	<p>No. of pulses, Relative or absolute operation, Port, CW/CCW, Independent, Acceleration/deceleration rate, Target frequency</p>	<p>---</p>
		<p>Pulse output starts at the specified frequency and stops immediately when the specified position is reached. (The target position can be changed during positioning (pulse output).)</p>	<p>PULS(886) (Electronic Cam Control)</p>	<p>Port, Target frequency, Absolute positioning</p>	<p>Use for absolute positioning (electronic cam control) with a single-phase output, no acceleration or deceleration, and target position changes in a fixed time interval. (See page 191.)</p>
		<p>The frequency accelerates at a fixed rate, decelerates at a fixed rate, and stops when the specified number of pulses have been output. (The number of pulses cannot be changed during positioning (pulse output).)</p>	<p>PLS2(887)</p>	<p>Port, CW/CCW, Acceleration rate, Deceleration rate, Target frequency, Starting frequency, No. of pulses</p>	<p>Use for trapezoidal acceleration/ deceleration within a set time (the dwell time) and then a repeat of the operation in the opposite direction. (See page 193.)</p>



Mode	Frequency changes	Description	Procedure		Example
			Instruc-tions	Settings	
Stop		Stops the pulse output immediately.	SPED(885) or ACC(888) or PULS(886) (Electronic Cam Control) ↓ INI(880)	Stop pulse output	---
		Stops the pulse output immediately.	SPED(885) or ACC(888) ↓ SPED(885)	Port, Continuous, Target frequency = 0	---
		Decelerates the pulse output to a stop.	SPED(885) or ACC(888) ↓ ACC(888)	Port, Continuous, Acceleration/ deceleration rate, Target frequency = 0	---

**Note** With ACC(888) and PLS2(887), the acceleration/deceleration rate's speed-change cycle can be set to 2ms or 1 ms. Also, the acceleration/deceleration rate can be set between 1 Hz and 9.999 kHz. Refer to 7-6-11 *Acceleration/Deceleration Rates in ACC(888) and PLS2(887) Instructions* for more details.

**Precautions when Using Pulse Outputs**

Pulses are output according to the clock frequency (20 MHz, 10 MHz, 5 MHz, 2.5 MHz, or 1.25 MHz) specified in the System Setup (Pulse Output/Clock). The clock signal is divided by an integer dividing ratio to create and output the output pulse frequency. This means that the actual frequency may not be the same as the target frequency. Refer to the following information to calculate the actual frequency.

The following information is used to calculate the output frequency.

**Target frequency:**

Set by user.

**Dividing ratio:**

An integer set in the dividing circuit used to generate the output pulses at the target frequency.

**Actual frequency:**

The actual frequency that is output as generated by the dividing circuit.

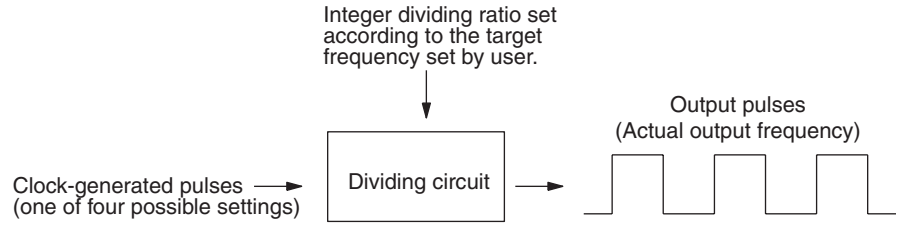

**Formula:**

Actual frequency = Clock frequency ÷ INT (clock frequency/target frequency)

**Note** INT (clock frequency/target frequency) is the dividing ratio.

The difference between the target frequency and the actual frequency increases at higher frequencies. The following tables shows examples for a clock frequency of 20 MHz.

Target frequency (Hz)	Actual output frequency
952,382 to 1,000,000	1,000,000
909,092 to 952,381	952,381
869,566 to 909,091	909,091
.	.
.	.
.	.
487,806 to 500,000	500,000
476,191 to 487,805	487,805
465,117 to 476,190	476,190
.	.
.	.
.	.
198,021 to 200,000	100,806
196,079 to 198,020	198,020
194,176 to 196,078	196,078
.	.
.	.
.	.
49,876 to 50,000	50,000
49,752 to 49,875	49,875
4,929 to 49,751	49,751
.	.
.	.
.	.
402	402
401	401
400	400

**7-6-7 One-shot Pulse Output Function**

The one-shot pulse output function turns ON the output only for a specified time between 0.01 and 9,999 ms. Use the STIM(980) instruction to start the pulse output (turn the output from OFF to ON). After the time specified in STIM(980) has elapsed, the pulse output is automatically turned OFF (in the hardware).

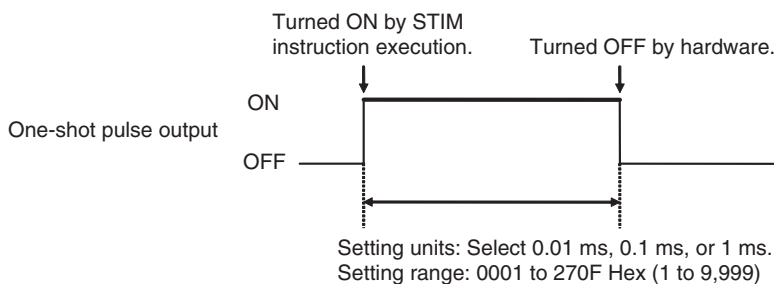

Set the pulse output operation mode to *1 shot* in advance in the System Setup, as shown in the following table.

Tab page	Function	Setting
Pulse Output	Pulse Output 1 – Operation mode	1 shot (one-shot pulse output)
	Pulse Output 2 – Operation mode	1 shot (one-shot pulse output)

**Note** A pulse output port that is being used for one-shot pulse outputs cannot be used for any other pulse output functions.

The elapsed time of the one-shot pulse output is stored in 8-digit hexadecimal in words A621 and A620 (pulse output 1) or A623 and A622 (pulse output 2). When the one-shot pulse output is turned ON, the content of the corresponding words is set to 0000 0000 hex and the content is incremented as time passes. The final value is retained when the one-shot output is turned OFF.

Word	Bits	Function	Contents	
A620	00 to 15	Elapsed time of One-shot pulse output 1	Lower 4 digits	Contains the elapsed time of the one-shot pulse output in 8-digit hexadecimal. The content can range from 0000 0000 to 0000 270F hex, and the units are set to 0.01 ms, 0.1 ms, or 1 ms with the STIM(980) instruction. <b>Note</b> These words are refreshed during the Motion Control Module's I/O refreshing.
A621	00 to 15		Upper 4 digits	
A622	00 to 15	Elapsed time of One-shot pulse output 2	Lower 4 digits	These words function just like the words for pulse output 1, described above.
A623	00 to 15		Upper 4 digits	

### One-shot Pulse Output Specifications

Item	Specification
Pulse ON time	0.01 to 9,999 ms (Can be set with the STIM(980) instruction.)
Operating conditions	1. Set the pulse output operation mode to <i>1 shot</i> in the System Setup. 2. Execute the STIM(980) instruction with operand C1 = #0001 or #0002.
Response time	Response time when the STIM(980) instruction is executed at the beginning of an interrupt task: 0.2 ms max. from the generation of the interrupt until the one-shot pulse output goes ON

### 7-6-8 Time Measurement with the Pulse Counter

The one-shot pulse output function can be used to create a high-precision pulse counter timer.

To measure time with high-precision, start the timer by executing the STIM(980) instruction with C1 = 000B or 000C and C2 = 0000, and stop the timer by executing STIM(980) with C1 = 000B or 000C and C2 = 0001.

Counting mode  
(Time measurement)

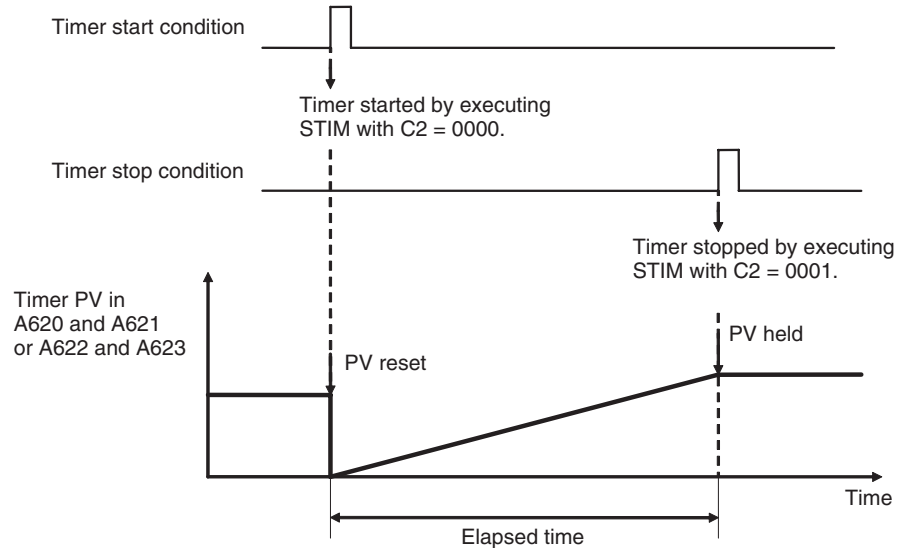

The timer's elapsed time is stored in 8-digit hexadecimal in words A621 and A620 (pulse output 1) or A623 and A622 (pulse output 2). When the timer starts, the corresponding words are initialized to 0000 0000 hex and the content is incremented as time passes. The final value is retained when the timer stops.

Word	Bits	Function	Contents	
A620	00 to 15	Pulse time measurement 1	Lower 4 digits	Contains the pulse counter's time measurement in 8-digit hexadecimal. The content can range from 0000 0000 to FFFF FFFF hex. <b>Note</b> These words are refreshed during the Motion Control Module's I/O refreshing.
A621	00 to 15		Upper 4 digits	
A622	00 to 15	Pulse time measurement 2	Lower 4 digits	These words function just like the words for pulse time measurement 1, described above.
A623	00 to 15		Upper 4 digits	

Set the pulse output operation mode to *Calculation (time measurement)* in advance in the System Setup, as shown in the following table.

Tab page	Function	Details
Pulse Output	Pulse output 1 – Operation mode	Calculation (time measurement)
	Pulse output 2 – Operation mode	

- Note**
- (1) The external pulse output from the port is disabled when this mode is selected.
  - (2) A pulse output port that is being used as a pulse counter timer cannot be used for any other pulse output functions.

- (3) If the STIM(980) instruction is executed again to restart an operating timer, the timer value will be reset to 0 and the timer will restart.

### **Pulse Counter Timer Specifications**

Item	Specification
Timer measurement range	0000 0000 to FFFF FFFF hex The time units can be set to 0.01 ms, 0.1 ms, or 1 ms with the STIM(980) instruction.
Operating conditions	<ol style="list-style-type: none"> <li>1. Set the pulse output operation mode to <i>Calculation (time measurement)</i> in the System Setup.</li> <li>2. To start or stop the timer, execute the STIM(980) instruction with operand C1 = #000B or #000C and one of the following C2 values: To start the timer, execute STIM(980) with operand C2 = #0000. To stop the timer, execute STIM(980) with operand C2 = #0001.</li> </ol>

### **7-6-9 Target-value Comparison Interrupts from Pulse Output PVs**

An interrupt task can be executed when the pulse output PV reaches a target value, although this function cannot be used in independent mode (positioning), one-shot pulse output operation mode, or electronic cam control because the pulse output stops.

When the pulse output operation mode is set to linear mode, this function can be used for speed control (frequency changes) based on the present position.

When the pulse output operation mode is set to circular mode, this function can be used for continuous speed control to control a series of repetitive operations at specific positions by repeating speed control patterns.

The processing of the target-value comparison interrupts for pulse output PVs is the same as the processing for high-speed counter PVs, so refer to *Checking for High-speed Counter Interrupts* under *High-speed Counter Function Description* in 7-5-8 *Pulse Input Function Description* for details.

**Linear Mode Operation**

A target value can be set at a desired pulse output PV to execute an interrupt task when the target value is reached. An ACC(888) or SPED(885) instruction can be programmed in the interrupt task to perform speed control at that target value.

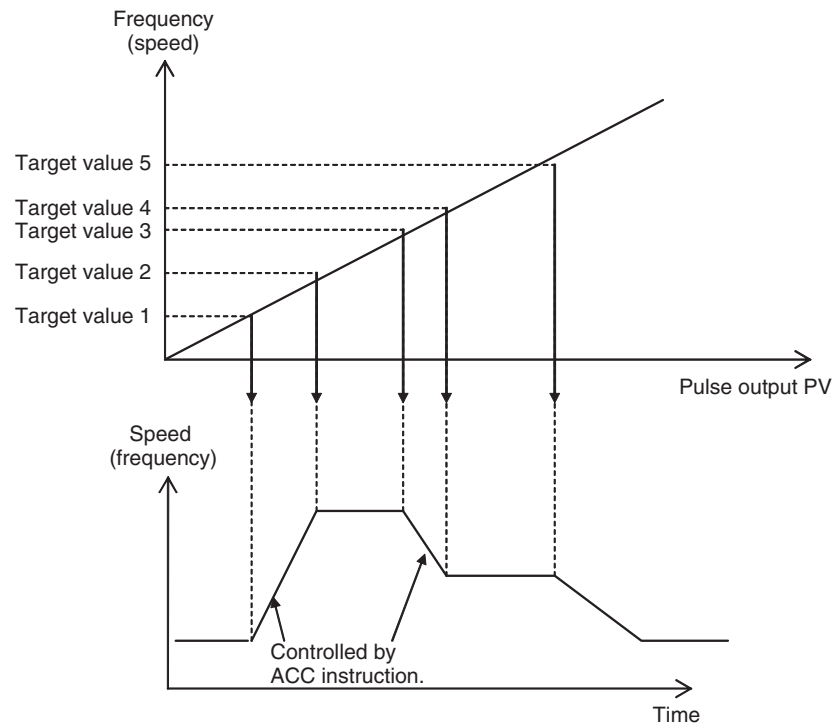

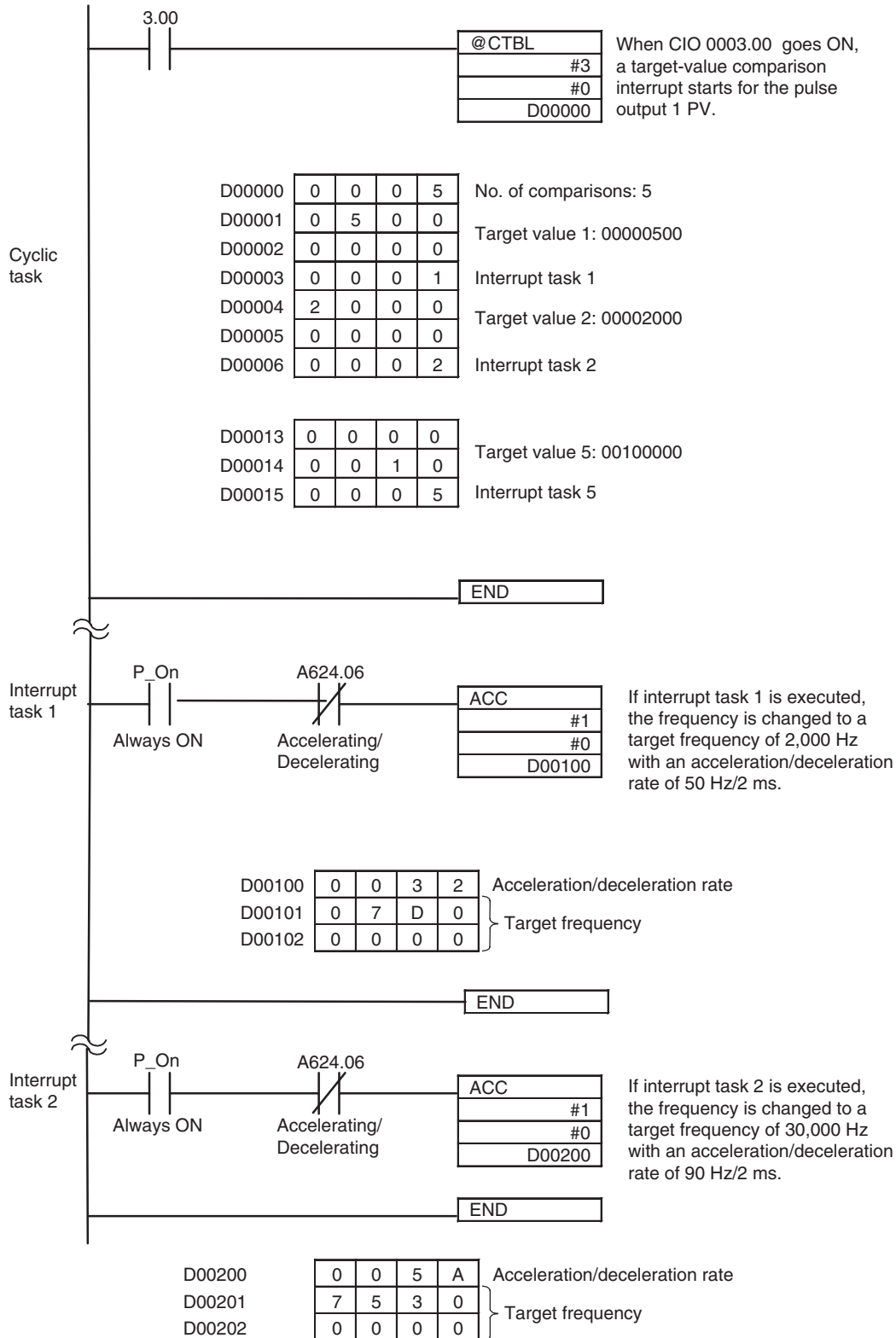

(Interrupt tasks 3, 4, and 5 are entered in the same way.)

**Circular Mode Operation**

A speed control pattern can be repeated in continuous speed control to control a series of repetitive operations at specific positions. For example, the following diagram shows an axis that repeatedly switches to low-speed operation at one position and switches to high-speed operation at another position. Since the speed control pattern must repeat in these applications, a counter cannot be used if it is reversible.

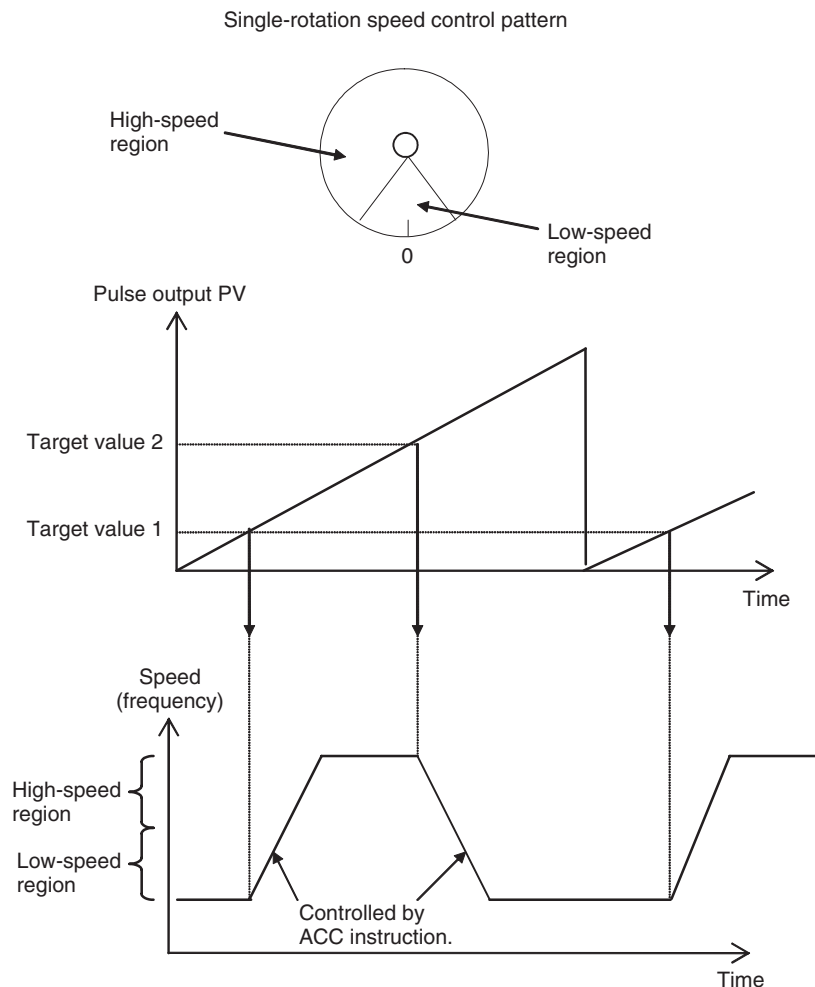

**7-6-10 Range Comparison Bit Pattern Outputs from Pulse Output PVs**

Bit patterns can be output internally in the Auxiliary Area when the pulse output PV is within a specified range.

The processing of the range-comparison bit pattern outputs for pulse output PVs is the same as the processing for high-speed counter PVs, so refer to *Checking for High-speed Counter Interrupts* under *High-speed Counter Function Description* in 7-5-8 *Pulse Input Function Description* for details.

**7-6-11 Acceleration/Deceleration Rates in ACC(888) and PLS2(887) Instructions**

The acceleration/deceleration rate's speed-change cycle can be set to either 1 ms or 2 ms for the ACC(888) and PLS2(887) instructions. The same speed-change cycle setting applies to both pulse output 1 and 2 and both the ACC(888) and PLS2(887) instructions.



### Setting the Speed-change Cycle

The speed change cycle for the ACC(888) and PLS2(887) instructions is specified by setting the ON/OFF bit status of A628.07 before executing the ACC(888) or PLS2(887) instruction.

#### 2-ms Cycle

Execute ACC(888) or PLS2(887) with A628.07 OFF.

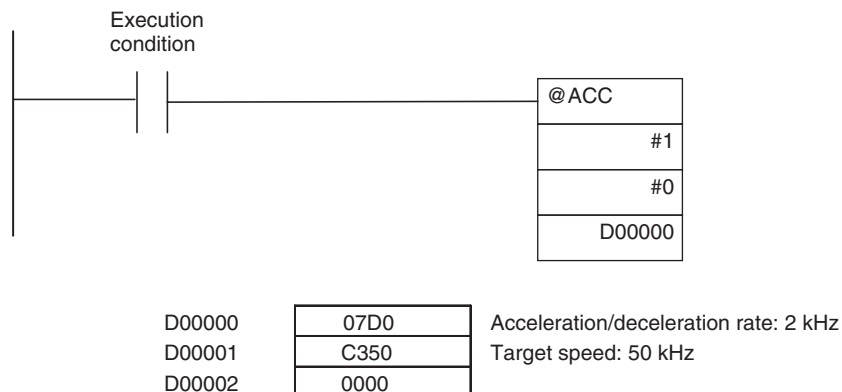

#### 1-ms Cycle

Execute ACC(888) or PLS2(887) with A628.07 ON.

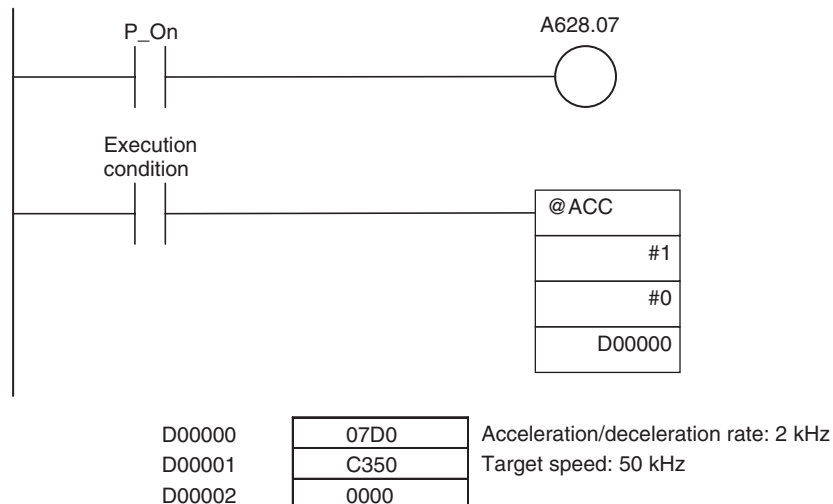

### 7-6-12 PLS2(887) Pulse Output Direction Priority Mode

The direction of pulses output by the PLS2(887) instruction can be determined manually based on a user-set operand (pulse output direction priority mode) or automatically based on the absolute position (absolute position priority mode).

#### Pulse Output Direction Priority Mode

The user determines the pulse output direction with an operand setting. Pulses will be output only when the output direction specified in the PLS2(887) instruction matches the direction determined from the absolute position.

#### Absolute Position Priority Mode

The pulse output direction is determined automatically from the absolute position. The Motion Control Module ignores the pulse output direction specified by the PLS2(887) operand setting. This mode allows positioning to be based on the absolute position only, so it is not necessary for the user to specify the direction.

**Setting the Pulse Output Direction Priority Mode**

The pulse output direction priority mode for the PLS2(887) instruction is specified by setting the ON/OFF bit status of A628.14 before executing the PLS2(887) instruction.

**Note** The priority mode setting in A628.14 applies to both pulse output 1 and 2.

**Pulse Output Direction Priority Mode**

Execute PLS2(887) with A628.14 OFF.

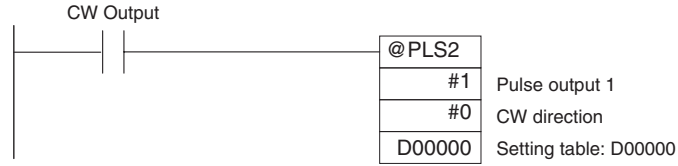

D00000	8000	} Target position: 8000 Hex
D00001	0000	
D00002	C350	} Target speed: 50 kHz
D00003	0000	
D00004	0000	} Starting speed: 0 Hz
D00005	0000	
D00006	03E8	Acceleration rate: 1,000 Hz
D00007	03E8	Deceleration rate: 1,000 Hz

**Absolute Position Priority Mode**

Execute PLS2(887) with A628.14 ON.

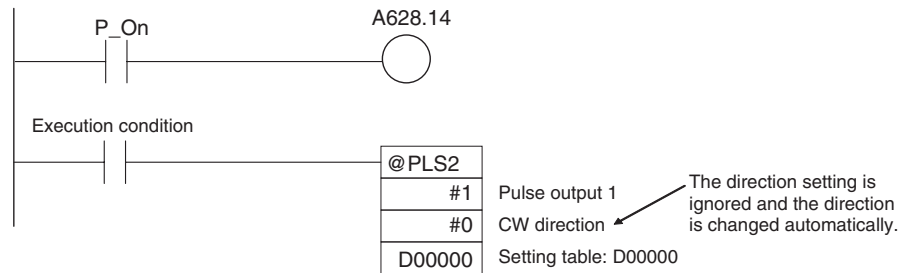

D00000	8000	} Target position: 8000 Hex
D00001	0000	
D00002	C350	} Target speed: 50 kHz
D00003	0000	
D00004	0000	} Starting speed: 0 Hz
D00005	0000	
D00006	03E8	Acceleration rate: 1,000 Hz
D00007	03E8	Deceleration rate: 1,000 Hz

**7-6-13 Pulse Output Function Procedures**

**Pulse Outputs without Acceleration/Deceleration (PULS(886) + SPED(885))**

This procedure shows how to use PULS(886) and SPED(885) to generate a single-phase pulse output without acceleration or deceleration. The number of output pulses **cannot** be changed during positioning.

- 1,2,3...**
1. Determine pulse output port.
    - Select pulse output 1 or 2.
  2. Wire the output.
    - Output: CW and CCW
    - Output power supply: 5 V DC
  3. Make the necessary System Setup settings (Pulse Output Tab Page – Operation Mode).
    - Set the pulse output operation mode (in the Pulse Output Tab Page – Operation Mode) to relative pulse output, absolute linear pulse output, or absolute circular pulse output.

- Set the clock speed for pulse outputs 1 and 2.
4. Create the necessary ladder programming.
    - Use PULS(886) to set number of output pulses for the specified port.
    - Use SPED(885) to start pulse output control without acceleration/deceleration from the specified port.
    - Use INI(880) to stop pulse output from the specified port.
    - Use PRV(881) to read the pulse output PV of the specified port.

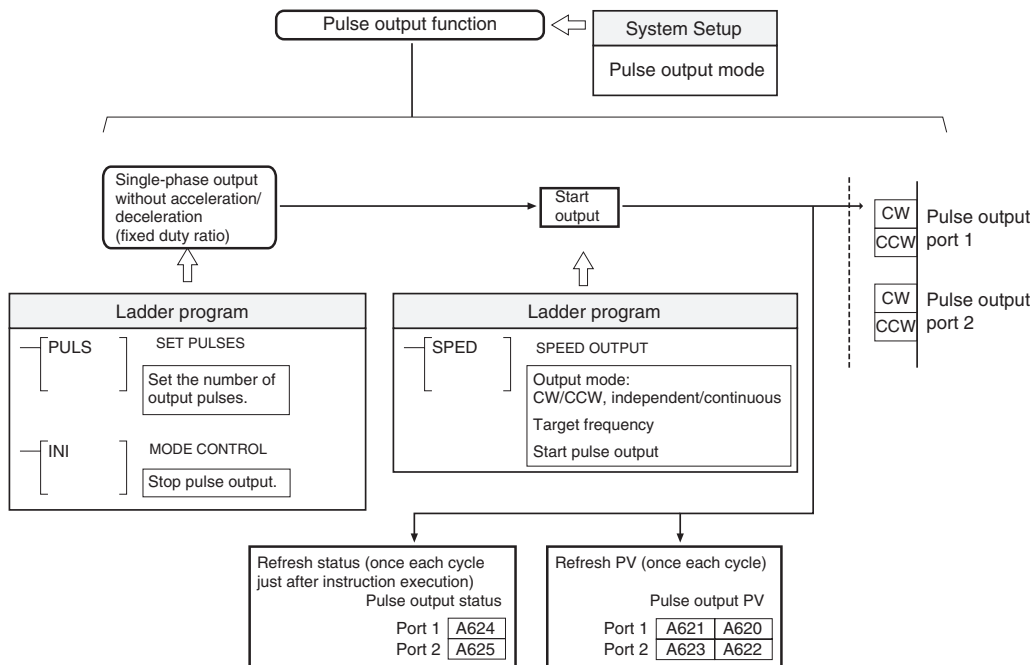

**Pulse Outputs with Acceleration/Deceleration**

This procedure shows how to use PULS(886) and ACC(888) to generate a pulse output with acceleration or deceleration. The number of output pulses **cannot** be changed during positioning.

- 1,2,3...
  1. Determine pulse output port.
    - Select pulse output 1 or 2.
  2. Wire the output.
    - Output: CW and CCW
    - Output power supply: 5 V DC
  3. Make the necessary System Setup settings (Pulse Output Tab Page – Operation Mode).
    - Set the pulse output operation mode (in the Pulse Output Tab Page – Operation Mode) to relative pulse output, absolute linear pulse output, or absolute circular pulse output.
    - Set the clock speed for pulse outputs 1 and 2.
  4. Create the necessary ladder programming.
    - Use PULS(886) to set number of output pulses for the specified port.
    - Use ACC(888) to start pulse output control with acceleration or deceleration from the specified port (acceleration and deceleration are specified separately).
    - Use INI(880) to stop pulse output from the specified port.

- Use PRV(881) to read the pulse output PV of the specified port.

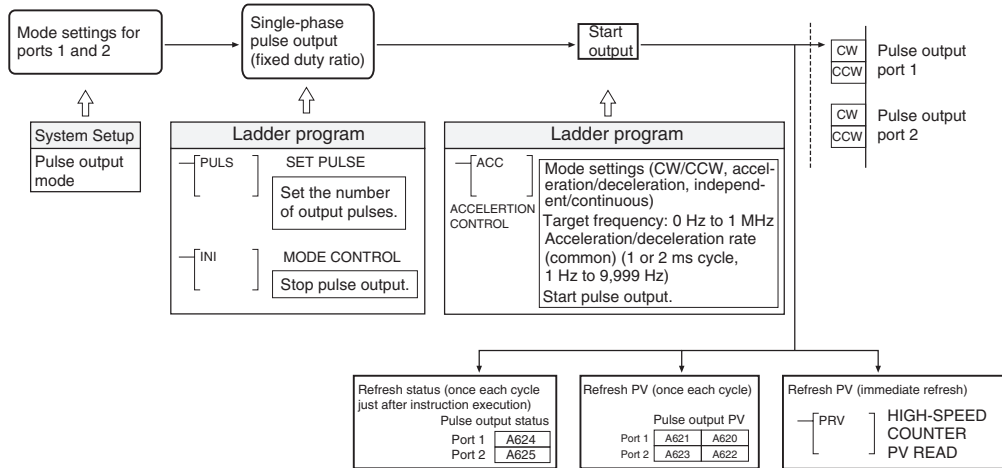

**Pulse Outputs without Acceleration/Deceleration (PULS(886): Electronic Cam Control)**

This procedure shows how to use the PULS(886) instruction’s electronic cam control function to generate a single-phase pulse output without acceleration or deceleration. The number of output pulses **can** be changed during positioning.

**Procedure**

**1,2,3...**

1. Determine pulse output port.
  - Select pulse output 1 or 2.
2. Wire the output.
  - Output: CW and CCW
  - Output power supply: 5 V DC
3. Make the necessary System Setup settings (Pulse Output Tab Page – Operation Mode).
  - Set the pulse output operation mode (in the Pulse Output Tab Page – Operation Mode) to absolute linear pulse output (electronic cam control) or absolute circular pulse output (electronic cam control).
  - Set the clock speed for pulse outputs 1 and 2.
4. Create the necessary ladder programming.
  - Use PULS(886) to set the absolute position, output frequency, and pulse output (automatic determination of pulse output direction) for the specified port.
  - Use INI(880) to stop pulse output from the specified port.
  - Use PRV(881) to read the pulse output PV of the specified port.

**Electronic Cam Control Functions**

The electronic cam control supports the following functions.

- The pulse output direction is determined automatically by comparing the present position (pulse output PV) and target position.
- The PULS(886) instruction can be executed during pulse output to change the absolute position setting and pulse frequency.
- Applications of Electronic Cam Operation:

The PULS(886) instruction (Electronic Cam Control) can be used to immediately change the pulse output value for absolute positioning or the pulse output frequency for speed control in response to the high-speed counter PV (e.g., for a rotational angle). This feature allows the Motion Control Module to perform electronic cam operation using simple linear approximation of a curve (for position or speed control based on the cam angle).

By setting a constant cycle time, the high-speed counter PV is read at regular intervals. The PULS(886) (Electronic Cam Control) instruction is executed immediately after reading the high-speed counter PV in order to determine the new target position for that cycle.

With the PULS(886) instruction (Electronic Cam Control), the target position or pulse output frequency (speed) can be changed by executing another instruction to change the target position or output frequency while the PULS(886) instruction is being executed. Consequently, position and speed control can be performed while outputting pulses, which is not possible with the PULS(886) + SPED(885) and PULS(886) + ACC(888) instruction combinations. This capability allows the target position or pulse output frequency (speed) to be changed in steps at high-speed in response to changes in the pulse input PV. In addition, the pulse input PV can be processed with operations such as basic arithmetic operations and the result can be used for the target position or pulse output frequency (speed).

**Note** The pulse output direction is selected automatically based on the relationship between the present position (pulse output PV) and target position.

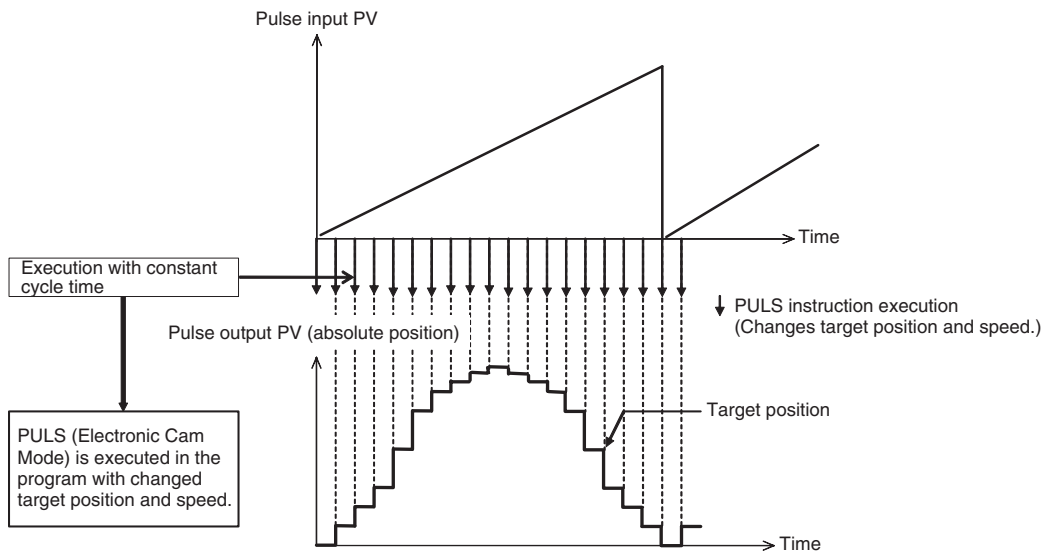

**Note** Speed control can be performed on a virtual axis by generating a virtual axis position (internal pulse count) with the AXIS instruction, processing that value with arithmetic operations or the APR instruction, and changing the target position or speed with the PULS(886) instruction. Refer to 7-8-4 Application Example for details.

**Trapezoidal Pulse Output with Acceleration/Deceleration (PLS2(887))**

This procedure shows how to use PLS2(887) to generate a pulse output with trapezoidal acceleration and deceleration. The number of output pulses **cannot** be changed during positioning.

- 1,2,3... 1. Determine pulse output port.

- Select pulse output 1 or 2.
2. Wire the output.
    - Output: CW and CCW
    - Output power supply: 5 V DC
  3. Make the necessary System Setup settings (Pulse Output Tab Page – Operation Mode).
    - Set the pulse output operation mode (in the Pulse Output Tab Page – Operation Mode) to relative pulse output or absolute linear pulse output.
    - Set the clock speed for pulse outputs 1 and 2.
  4. Create the necessary ladder programming.
    - Use PLS2(887) to start pulse output control with trapezoidal acceleration/deceleration from the specified port (acceleration and deceleration are specified separately).
    - Use INI(880) to stop pulse output from the specified port.
    - Use PRV(881) to read the pulse output PV of the specified port.

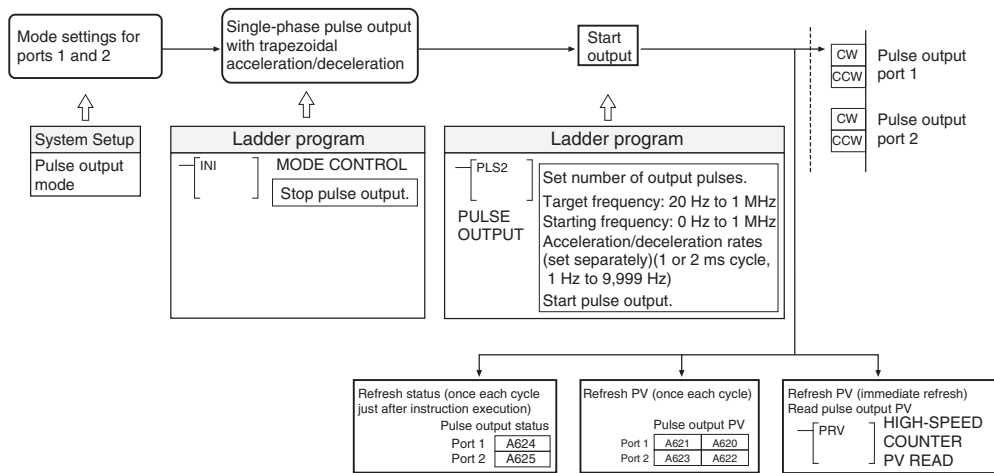

**One-shot Pulse Output (STIM(980))**

- 1,2,3...
1. Determine pulse output port.
    - Select pulse output 1 or 2.
  2. Wire the output.
  3. Make the necessary System Setup settings.
    - Set the pulse output operation mode (in the Pulse Output Tab Page – Operation Mode) to 1 shot.
  4. Create the necessary ladder programming.
    - Use STIM(980) (with C1 = #0001 or #0002) to turn ON the one-shot pulse output.

**Note** The STIM(980) one-shot pulse output function can be used at the same time as an STIM(980) timer interrupt function (one-shot timer or scheduled timer).

**Pulse Counter Timer Function (STIM(980))**

- 1,2,3...
1. Determine pulse output port.
    - Select pulse output 1 or 2.
  2. Make the necessary System Setup settings.

- Set the pulse output operation mode (in the Pulse Output Tab Page – Operation Mode) to *Calculation (time measurement)*.
3. Create the necessary ladder programming.
    - a. Use STIM(980) with C1 = #000B or #000C and C2 = #0000 to start measurement.
    - b. Use STIM(980) with C1 = #000B or #000C and C2 = #0001 to stop measurement.

**Note** The STIM(980) pulse counter timer function used at the same time as an STIM(980) timer interrupt function (one-shot timer or scheduled timer).

## 7-6-14 Pulse Output Function Examples

### Positioning using Pulse Outputs without Acceleration/Deceleration

In the following positioning example, the PULS(886) and SPED(885) instructions are used to control a relative pulse output from port 1 (CW independent mode positioning). The number of pulses specified in PULS(886) (10,000) are output at the frequency specified in SPED(885) (2,000 Hz).

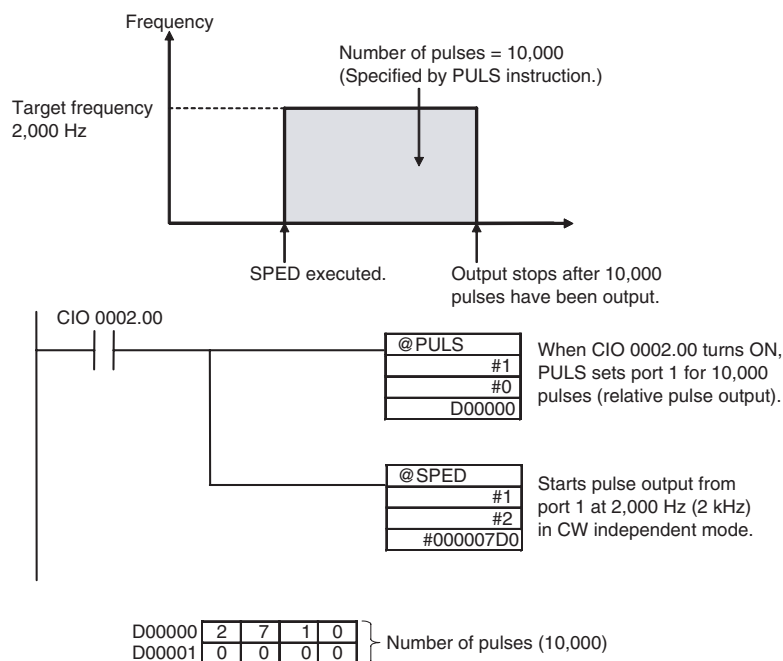

**Caution** Be sure that the pulse frequency is within the motor's self-starting frequency range when starting and stopping the motor.

### Changing the Frequency in Steps

In this example, the SPED(885) instruction is used to change the speed of a pulse output from port 2 from a frequency of 3,000 Hz to 50,000 Hz. In this case, the pulse output is a CCW continuous mode output.

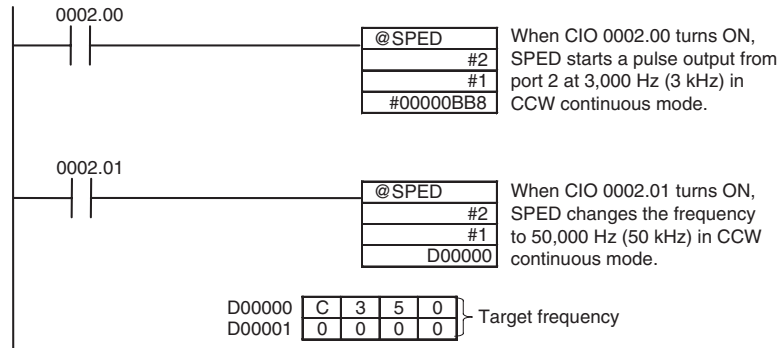
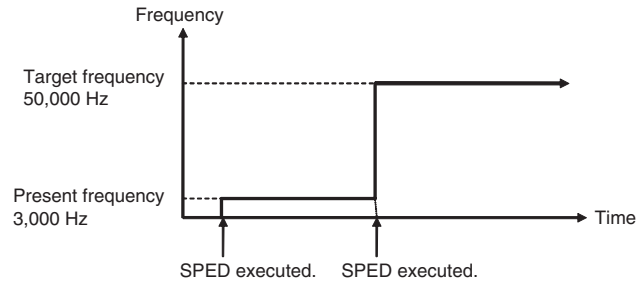

**Note** Speed control timing will be accurate when frequency changes are executed by SPED(885) instructions in interrupt tasks called by input interrupts.

### Accelerating the Frequency at a Fixed Rate

In this example, the ACC(888) instruction is used to accelerate the pulse output from port 2 from a frequency of 3,000 Hz to 50,000 Hz at an acceleration rate of 500 Hz/2 ms.

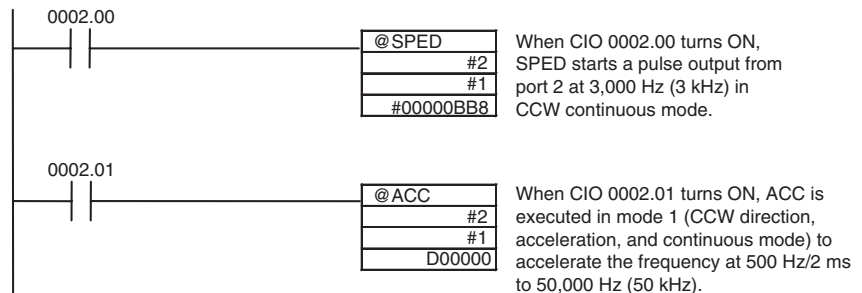
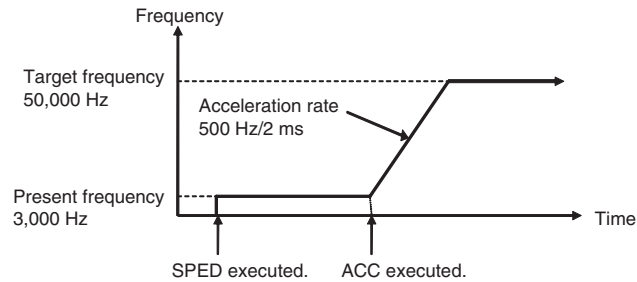



**Note** The pulse output can be stopped by executing ACC(888) with a deceleration target frequency of 0. However, since the pulse output cannot be stopped at the correct number of pulses, the deceleration target frequency should not be set to 0 if it is necessary to output a precise number of pulses.

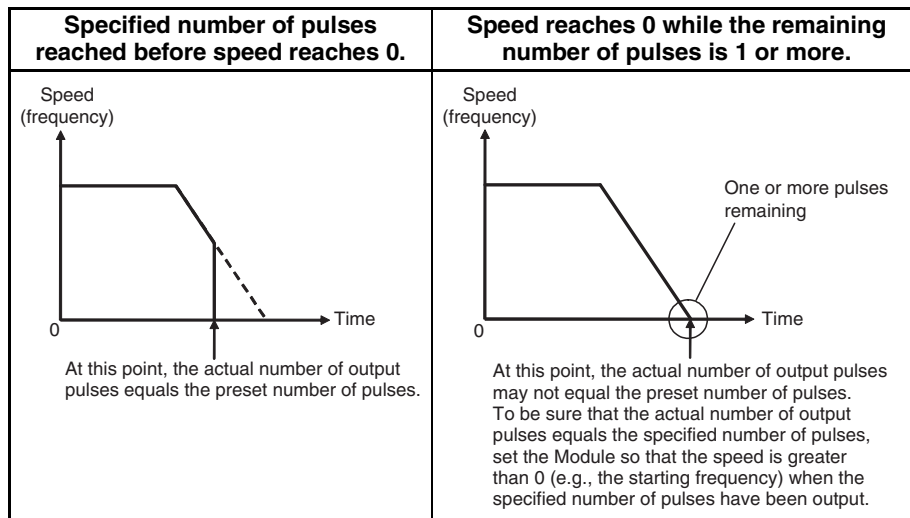

**Absolute Positioning with Continually Changing Target Position**

This example performs absolute positioning (Electronic Cam Control) using a single-phase pulse output without acceleration/deceleration, and the target position is updated every cycle. This function relies on a constant cycle time, in which the ladder program is executed every 2 ms, and positioning is performed using a target value that is changed every cycle according to the high-speed counter PV.

The pulse output is controlled by the target position, which is calculated repeatedly from the high-speed counter PV. The target position is calculated, so the APR instruction can be used for linear approximation.

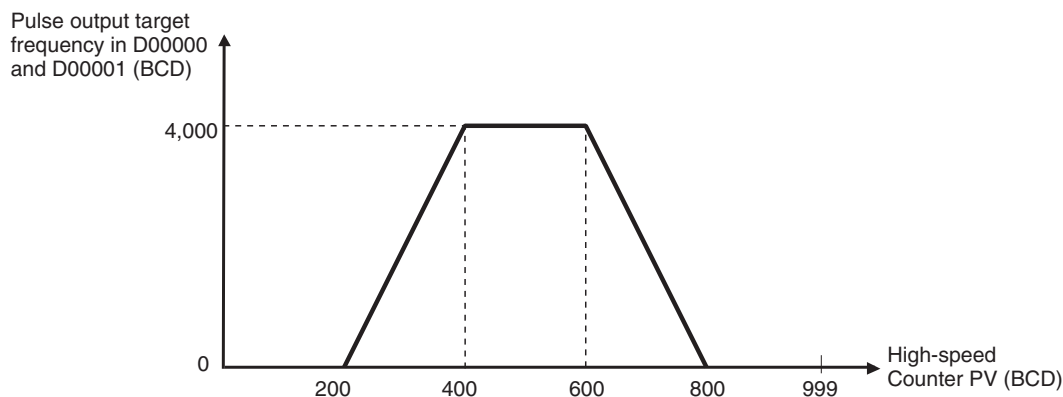

The high-speed counter is set for circular operation with a circular value of 999 BCD.

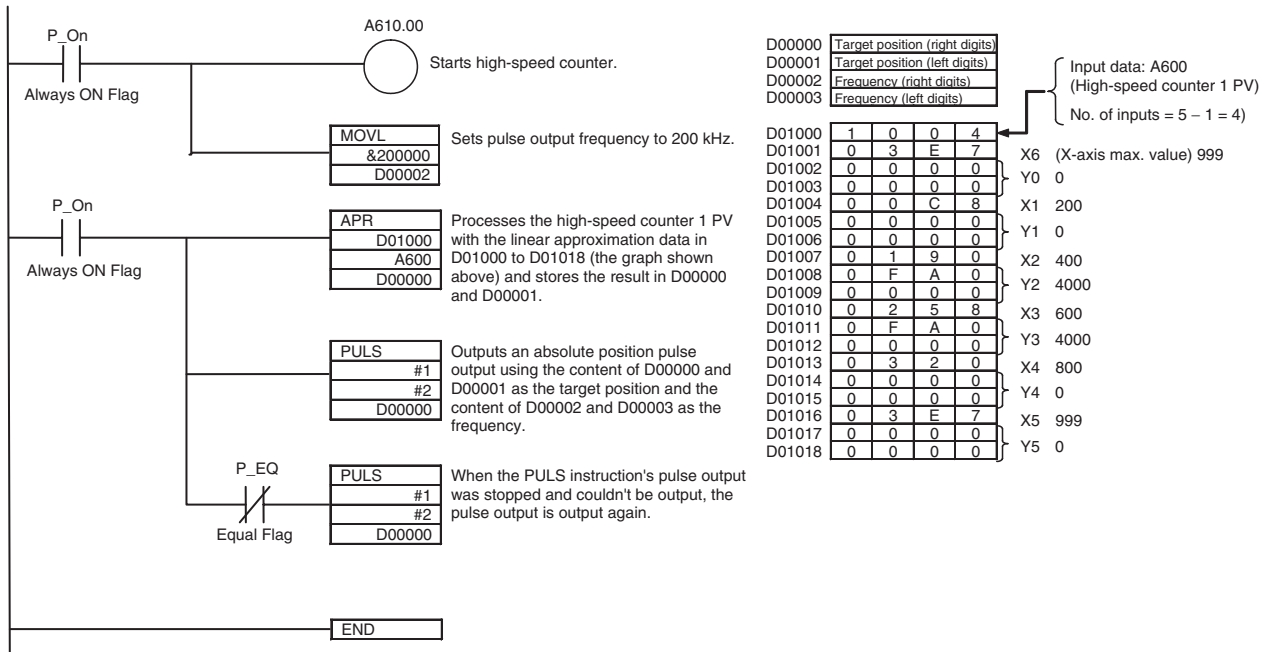

### Using PLS2(887) for Trapezoidal Acceleration/Deceleration

In this example, the axis is accelerated in the CW direction at 500 Hz/2 ms, the acceleration/deceleration rate is reduced to 300 Hz/2 ms, and the pulse output is stopped after 300,000 pulses have been output.

After 5 s, the same trapezoidal acceleration/deceleration operation is performed in the CCW direction.

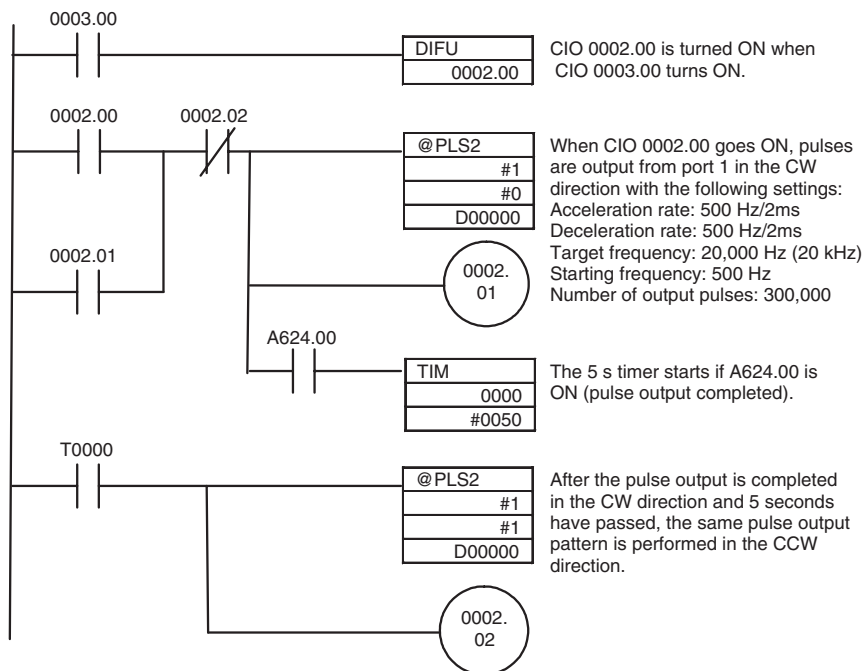
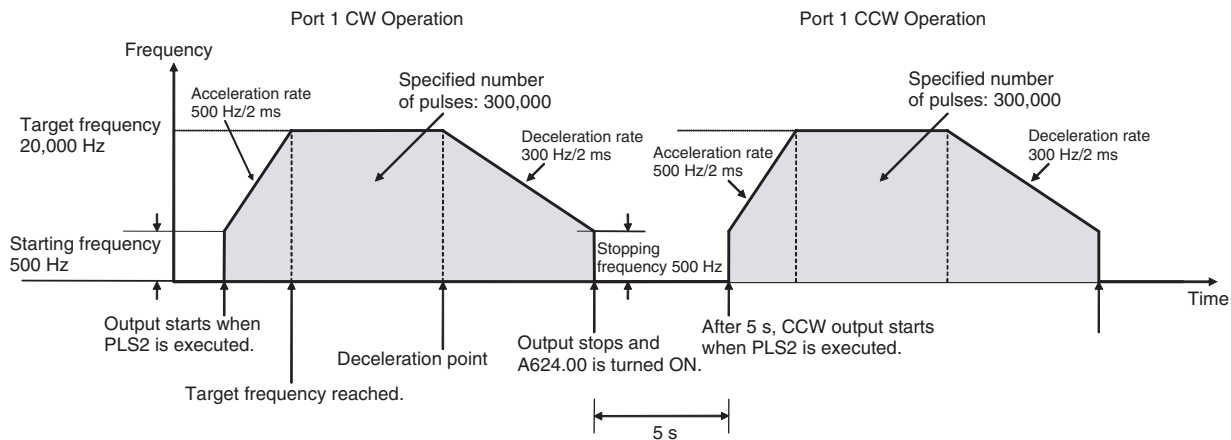

T	D00000	9	3	E	0	} Number of output pulses
T+1	D00001	0	0	0	4	
T+2	D00002	4	E	2	0	} Target frequency
T+3	D00003	0	0	0	0	
T+4	D00004	0	1	F	4	} Starting frequency
T+5	D00005	0	0	0	0	
T+6	D00006	0	1	F	4	} Acceleration rate
T+7	D00007	0	1	2	C	

**Note** When PLS2(887) cannot perform trapezoidal positioning with the trapezoidal acceleration/deceleration settings, it will perform triangular positioning with the same acceleration/deceleration settings. In this case, the PLS2(887) Tar-

get Frequency Not Reached Flag (A624.02 or A625.02) will turn ON at the peak of the triangular pattern and turn OFF when deceleration is completed.

**One-shot Pulse Output Function Example**

In this example, STIM(980) is used to generate a 1.5-ms one-shot pulse output from pulse output 1.

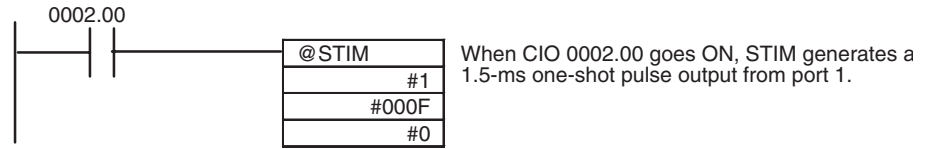

**Pulse Counter Time Measurement (Timer) Example**

In this example, a pulse counter timer is allocated to pulse output 1.

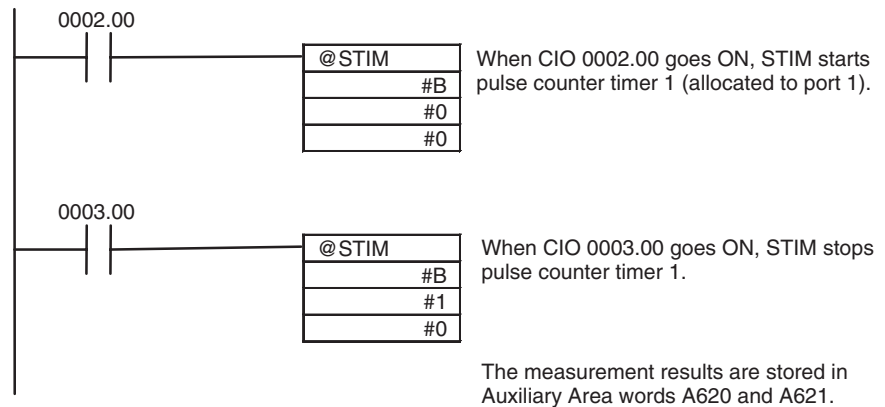

**7-6-15 Pulse Output Starting Conditions**

**Pulse Output Operation Modes Supported by Instruction**

Pulse output operation mode	Starting instruction							
	SPED(885)	PULS(886) (with output)	ACC(888)	PLS2(887)	STIM(980) (One-shot)	STIM(980) (Timer)	INI(880) (Change PV)	INI(880) (Stop pulse output)
Relative pulse output	OK	No	OK	OK	No	No	OK (note 1)	OK
Absolute pulse output (linear)	OK	No	OK	OK	No	No	OK	OK
Absolute pulse output (circular)	OK	No	OK	No	No	No	OK	OK
Electronic Cam Control (linear)	No	OK	OK (note 2)	OK (note 3)	No	No	OK	OK
One-shot pulse mode	No	No	No	No	OK	No	OK (note 1)	No
Pulse counter timer	No	No	No	No	No	OK	OK (note 1)	No
Electronic Cam Control (circular)	No	OK	OK (note 2)	OK (note 3)	No	No	OK	OK

- Note**
- (1) Even if the PV is changed, it will start from 0 at startup.
  - (2) Supports continuous mode only.

(3) Use this function for positioning.

**Allowed Startup Conditions for Pulse Output Operations (with Output Stopped)**

The following table shows when an independent mode pulse output (SPED(885) independent mode, ACC(888) independent acceleration mode, or ACC(888) independent deceleration mode) can be started when pulses are not being output.

Startup conditions and status		Startup mode and conditions					
		Relative pulse output CW	Relative pulse output CCW	Absolute linear CW	Absolute linear CCW	Absolute circular CW	Absolute circular CCW
Relative		OK	OK	---	---	---	---
Absolute linear	Target position > Present position	---	---	OK	OK with SPED(885), ACC(888) Disabled with PLS2(887)	---	---
	Target position < Present position	---	---	OK with SPED(885), ACC(888) Disabled with PLS2(887)		---	---
	Target position = Present position	---	---	No	No	---	---
Absolute circular	Target position > Present position	---	---	---	---	OK	OK
	Target position < Present position	---	---	---	---	OK	OK
	Target position = Present position	---	---	---	---	OK	OK

The following table shows when a continuous mode pulse output (SPED(885) continuous mode, ACC(888) continuous acceleration mode, or ACC(888) continuous deceleration mode) can be started when pulses are not being output..

Startup conditions and status		Startup mode and conditions					
		Relative pulse output CW	Relative pulse output CCW	Absolute linear CW	Absolute linear CCW	Absolute circular CW	Absolute circular CCW
Relative		OK	OK	---	---	---	---
Absolute linear	Target position = Maximum value	---	---	OK	OK	---	---
	Target position = Minimum value	---	---	OK	OK	---	---
Absolute circular	Target position = Maximum value	---	---	---	---	OK	OK
	Target position = Minimum value	---	---	---	---	OK	OK

**PULS(886) Absolute Pulse Output in Progress**

Pulse Output Operation Mode (Absolute Linear) Limitations **PLS2(887)**

Startup conditions and status		Startup mode and conditions					
		Relative CW	Relative CCW	Pulse output direction priority mode (A628.14 = 0)		Absolute position priority mode (A628.14 = 1)	
				Absolute linear CW	Absolute linear CCW	Absolute linear CW	Absolute linear CCW
Relative		OK	OK	---	---	---	---
Absolute linear	Target position > Present position	---	---	OK	No	OK	OK
	Target position = Present position	---	---	No	No	No	No
	Target position < Present position	---	---	No	OK	OK	OK

**Startup Conditions when other Instructions are being Executed**

Operating instruction		Starting instruction									
		SPED(885) independent	SPED(885) continuous	PULS(886) relative, without output	PULS(886) absolute without output	PULS(886) absolute with output	ACC(888) acceleration, continuous	ACC(888) deceleration, continuous	ACC(888) acceleration, independent	ACC(888) deceleration, independent	PLS2(887)
SPED(885)	Independent	OK	No	No	No	No	No	No	OK	OK	No
SPED(885)	Continuous	OK (See note 2.)	OK	OK	OK	No	OK	OK	OK (See note 2)	OK (See note 2)	No
PULS(886)	No relative output	OK	OK	OK	---	No	OK	OK	OK	OK	(See note 1)
PULS(886)	No absolute output	OK	OK	---	OK	No	OK	OK	OK	OK	(See note 1)
PULS(886)	Relative output	No	No	No	No	OK	No	No	No	No	No
ACC(888)	Acceleration + continuous	Accelerating	No	No	OK	OK	No	No	No	No	No
		Steady speed	OK (See note 2)	OK	OK	OK	No	OK	OK	OK (See note 2)	OK (See note 2)
ACC(888)	Deceleration + continuous	Decelerating	No	No	OK	OK	No	No	No	No	No
		Steady speed	OK (See note 2)	OK	OK	OK	No	OK	OK	OK (See note 2)	OK (See note 2)
ACC(888)	Acceleration + independent	Accelerating	No	No	No	No	No	No	No	No	No
		Steady speed	OK	No	No	No	No	No	No	OK	OK
ACC(888)	Deceleration + independent	Decelerating	No	No	No	No	No	No	No	No	No
		Steady speed	OK	No	No	No	No	No	No	OK	OK
PLS2(887)		No	No	No	No	No	No	No	No	No	No

- Note**
- (1) Cancel the number of output pulses set with PULS(886) and then execute PLS2(887).
  - (2) Execution is OK when the number of output pulses has been set.

**Allowed Startup Conditions for Pulse Output Operations (with Output in Progress)**

Operating instruction		Starting instruction									
		SPED(885) independent	SPED(885) continuous	PULS(886) relative, without output	PULS(886) absolute without output	PULS(886) absolute with output	ACC(888) acceleration, continuous	ACC(888) deceleration, continuous	ACC(888) acceleration, independent	ACC(888) deceleration, independent	PLS2(887)
SPED(885)	Independent	Case (1)	No	No	No	No	No	No	Case (8)	Case (11)	No
SPED(885)	Continuous	Case (2)	Case (4)	Yes	Yes	No	Case (6)	Case (7)	Case (9)	Case (12)	No
PULS(886)	No relative output	Yes	Yes	Yes	---	No	Yes	Yes	Yes	Yes	(See note.)

Operating instruction		Starting instruction									
		SPED(885) independent	SPED(885) continuous	PULS(886) relative, without output	PULS(886) absolute without output	PULS(886) absolute with output	ACC(888) acceleration, continuous	ACC(888) deceleration, continuous	ACC(888) acceleration, independent	ACC(888) deceleration, independent	PLS2(887)
PULS(886)	No absolute output	Yes	Yes	---	Yes	No	Yes	Yes	Yes	Yes	(See note.)
PULS(886)	Absolute output	No	No	No	No	Case (5)	No	No	No	No	No
ACC(888)	Acceleration + continuous	Accelerating	No	No	Yes	Yes	No	No	No	No	No
		Steady speed	Case (2)	Case (4)	Yes	Yes	No	Case (6)	Case (7)	Case (9)	Case (12)
ACC(888)	Deceleration + continuous	Decelerating	No	No	Yes	Yes	No	No	No	No	No
		Steady speed	Case (2)	Case (4)	Yes	Yes	No	Case (6)	Case (7)	Case (9)	Case (12)
ACC(888)	Acceleration + independent	Accelerating	No	No	No	No	No	No	No	No	No
		Steady speed	Case (3)	No	No	No	No	No	No	Case (10)	Case (13)
ACC(888)	Deceleration + independent	Decelerating	No	No	No	No	No	No	No	No	No
		Steady speed	Case (3)	No	No	No	No	No	No	Case (10)	Case (13)
PLS2(887)		No	No	No	No	No	No	No	No	No	No

**Note** Cancel the number of output pulses set with PULS(886) and then execute PLS2(887).

Cases (1), (2), and (3)

Output status		Starting instruction and conditions			
		SPED(885), independent, relative		SPED(885), independent, absolute (linear or circular)	
		CW	CCW	CW	CCW
Relative	CW output	Yes	No	---	---
	CCW output	No	Yes	---	---
Absolute linear or circular	CW output	---	---	Yes	No
	CCW output	---	---	No	Yes

Case (4)

Output status		Starting instruction and conditions					
		SPED(885), continuous, relative		SPED(885), continuous, absolute linear		SPED(885), continuous, absolute circular	
		CW	CCW	CW	CCW	CW	CCW
Relative	CW output	Yes	No	---	---	---	---
	CCW output	No	Yes	---	---	---	---
Absolute linear	CW output	---	---	Yes	No	---	---
	CCW output	---	---	No	Yes	---	---
Absolute circular	CW output	---	---	---	---	Yes	No
	CCW output	---	---	---	---	No	Yes

Case (5)

Output status		Starting instruction and conditions	
		PULS(886) absolute linear output in progress Target position > Present position	PULS(886) absolute linear output in progress Target position < Present position
Absolute linear	CW output	Yes	Yes (See note.)
	CCW output	Yes (See note.)	Yes

**Note** The pulse output will stop. After the axis stops, it must be restarted.

Cases (6), (8), (9), and (10)

- Starting instruction: ACC(888) (continuous or independent), acceleration, relative

Output status		Direction and starting conditions			
		CW		CCW	
		Target position > Present position	Target position < Present position	Target position > Present position	Target position < Present position
Relative	CW output	Yes	No	No	No
	CCW output	No	No	Yes	No

- Starting instruction: ACC(888) (continuous or independent), acceleration, absolute linear

Output status		Direction and starting conditions			
		CW		CCW	
		Target position > Present position	Target position < Present position	Target position > Present position	Target position < Present position
Absolute linear	CW output	Yes	No	No	No
	CCW output	No	No	Yes	No

- Starting instruction: ACC(888) (continuous or independent), acceleration, absolute circular

Output status		Direction and starting conditions			
		CW		CCW	
		Target position > Present position	Target position < Present position	Target position > Present position	Target position < Present position
Absolute circular	CW output	Yes	No	No	No
	CCW output	No	No	Yes	No

Cases (7), (11), (12), (13)

- Starting instruction: ACC(888) (continuous or independent), deceleration, relative

Output status		Direction and starting conditions			
		CW		CCW	
		Target position > Present position	Target position < Present position	Target position > Present position	Target position < Present position
Relative	CW output	No	Yes	No	No
	CCW output	No	No	No	Yes

- Starting instruction: ACC(888) (continuous or independent), deceleration, absolute linear

Output status		Direction and starting conditions			
		CW		CCW	
		Target position > Present position	Target position < Present position	Target position > Present position	Target position < Present position
Absolute linear	CW output	No	Yes	No	No
	CCW output	No	No	No	Yes



- Starting instruction: ACC(888) (continuous or independent), deceleration, absolute circular

Output status		Direction and starting conditions			
		CW		CCW	
		Target position > Present position	Target position < Present position	Target position > Present position	Target position < Present position
Absolute circular	CW output	No	Yes	No	No
	CCW output	No	No	No	Yes

## 7-7 Functions for Servo Drivers Compatible with Absolute Encoders

### 7-7-1 Applicable Models

Model	Functions
FQM1-MMP21	Motion Control Module for Pulse I/O
FQM1-MMA21	Motion Control Module for Analog I/O

The examples in this section demonstrate the functions with high-speed counter 1 only. When using high-speed counter 2, replace the Auxiliary Area addresses with the appropriate addresses for high-speed counter 2.

### 7-7-2 Overview

Either of the following types of pulse input signals can be input to the unit:

- Pulse trains from normal incremental encoders, etc.
- Encoder output data (e.g., OMRON's W Series) of Servo Drivers compatible with absolute encoders (multi-turns absolute encoders)

The following explains the functions that are compatible with the latter, Servo Drivers compatible with absolute encoders.

**Note** Refer to *7-5 Pulse Inputs* for details on pulse train inputs from devices such as normal incremental encoders

To input the encoder output data from a Servo Driver compatible with an absolute encoder, the SEN output signal from the Motion Control Module has to be connected to the Servo Driver. When starting an operation, the number of multi-turns (to phase A as serial data) and the initial incremental pulse (to phase A/B as pulse) are input once as the absolute position information.

After that, the position data during operations are input with the phase differential input (using normal counter functions).

Using a Servo Driver compatible with an absolute encoder enables the controlled operation to be started from the position at turning on the power without performing any origin searches.

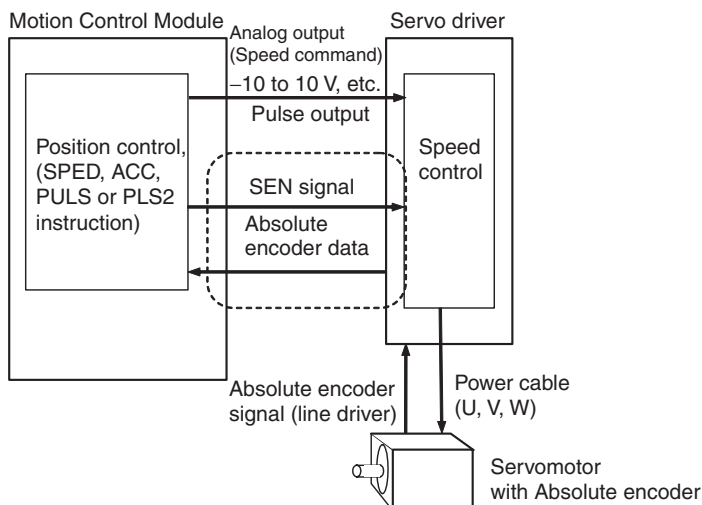

### 7-7-3 Data Format of Absolute Encoder Output

The format of data from a Servo Driver compatible with an absolute encoder supported by the Motion Control Module is as follows:

#### Serial Data Specification

The number of digits for rotation data	5 digits
Data transmitting method	Asynchronous
Baud rate	9,600 bits/s
Start bit	1 bit
Stop bit	1 bit
Parity	Even numbers
Character code	ASCII 7 bits
Data format	8 characters

#### Data Format

Byte	+0	+1	+2	+3	+4	+5	+6	+7
	P (See note 1.)	Rotation data						CR
		Sign (+ or -)	Integer (5-digit decimal)					

- Note**
- (1) The “P” is in ASCII. It is 50 hex in hexadecimal.
  - (2) The range of No. of rotations that can be received by the Motion Control Module is between +65,535 to -65,535.
  - (3) For details of the data on the number of multi-turns received from a Servo Driver, please check the manual of the Servo Driver in use.
  - (4) Set the System Setup’s Counter 1 Counter operation to either an absolute linear (CW-) or absolute linear (CW+) counter corresponding to the setting of reverse rotation mode on the Servo Driver in use.
  - (5) When the mode where the data on the number of rotations is output only in the + direction is set in the absolute encoder multi-turn limit setting, the data received by the Motion Control Module is handled as described below according to the setting of Counter 1 Counter operation in the System Setup.

• Example 1

A value between 0 and 65,534 is set in the Servo Driver, the System Setup's Counter 1 Counter operation is set to an absolute linear (CW-) counter, and the Servo Driver's reverse rotation mode setting (Pn000.0) is set to 0 (+ command for rotation in CCW direction).

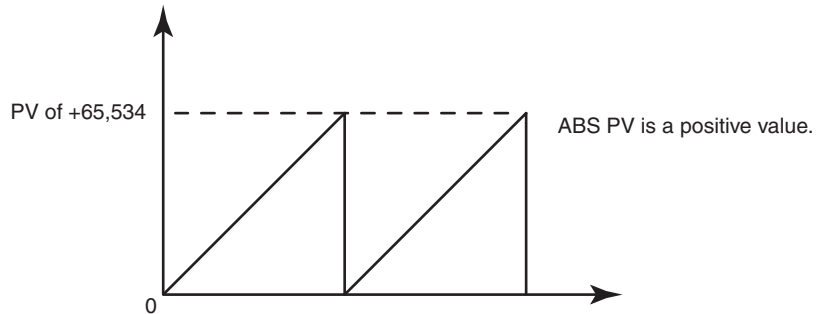

• Example 2

The System Setup's Counter 1 Counter operation is set to an absolute linear (CW+) counter and the Servo Driver's reverse rotation mode setting (Pn000.0) is set to 1 (+ command for rotation in CW direction).

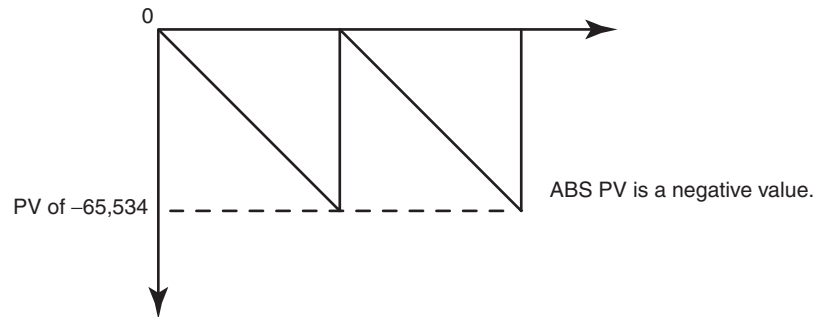

**Note** When using an absolute linear (CW-) counter, the phase-B phase can be inverted with an FQM1-series Servo Relay Unit so that the Servo Driver's operation matches the pulse output operation.

### 7-7-4 Counter Operation

#### Counting Operation

The counting operations performed in the absolute linear (CW-), absolute linear (CW+), and absolute circular counters are the same as the pulse input function's linear and circular counters. However, the normal linear counter does not have the function that receives the rotation data stored in a Servo Driver compatible with an absolute encoder.

#### Counter Operation Details

##### **Absolute Linear (CW-) Counter (CCW Rotation for + Count)**

The details of the absolute linear (CW-), absolute linear (CW+), and absolute circular counters are as follows:

When an absolute encoder rotates in reverse, the pulse information is counted with a linear counter. Use this mode when the Servo Driver's reverse rotation mode parameter has been set to positive (+) command for CCW rotation.

##### **Absolute Linear (CW+) Counter (CW Rotation for + Count)**

When an absolute encoder rotates forward, the pulse information is counted with a linear counter. Use this mode when the Servo Driver's reverse rotation mode parameter has been set to positive (+) command for CW rotation.

**Absolute Circular Counter** The absolute encoder's pulse information is counted using a circular counter. (Only the initial incremental pulse (angle) reading is used as the absolute value.)

### 7-7-5 Absolute Number of Rotations PV (Counter 1: A604 and A605)

The multi-turn data (a present value read from an encoder) is input to the Motion Control Module after the SEN signal is input to a Servo Driver. The data is stored as the absolute number of rotations present value. The stored value is determined by the following conversion formulae:

$$\text{Absolute number of rotations PV (A604 and A605)} = R \times M$$

$$\text{Number of initial incremental pulses (A600 and A601)} = P_0$$

M: Multi-turn data (meaning how many times the axis of a rotary encoder rotated)

R (System Setup: ABS encoder resolution): The number of pulses for encoder's one revolution

(Absolute encoder's resolution set on Servo Driver x phase differential input multiplication of the Motion Control Module (System Setup: Counter 1 Input))

$P_0$ : The number of initial incremental pulses

$P_s$ : Absolute offset

When the absolute number of rotations value is read, the number of initial incremental pulses portion is stored in A600 and A601.

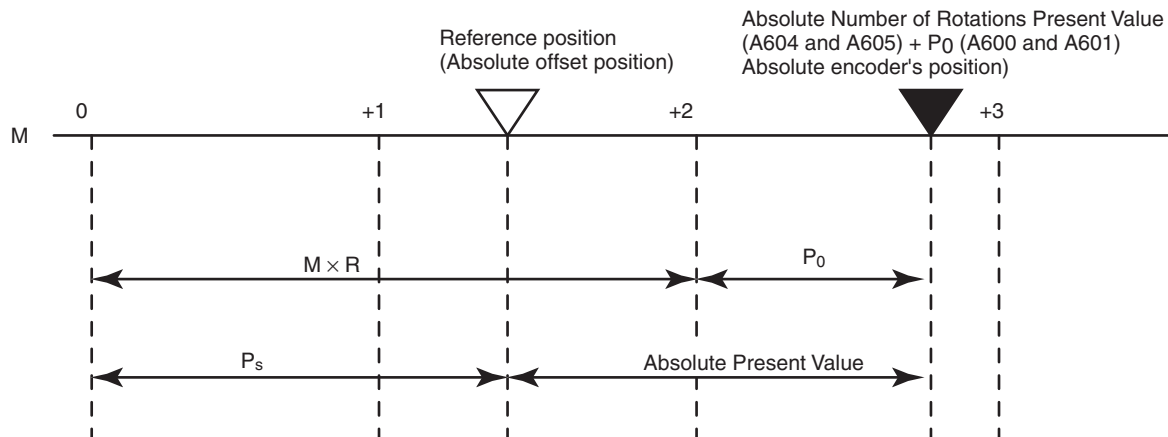

### 7-7-6 Absolute Present Value

The absolute present value is calculated by subtracting an absolute offset from the absolute encoder's state (position) when the SEN signal was turned ON.

The value is calculated using the following formulae and is used for the absolute present value preset function. It is not stored in the memory as data.

#### Absolute Linear Counter

$$\text{Absolute PV} = \text{Absolute number of rotations PV (A604 and A605)} + \text{Number of initial incremental pulses (A600 and A601)} - P_s$$

$P_s$ : Absolute offset

#### Absolute Circular Counter

$$\text{Absolute PV} = P_0 - P_s$$

$P_0$ : The number of initial incremental pulses

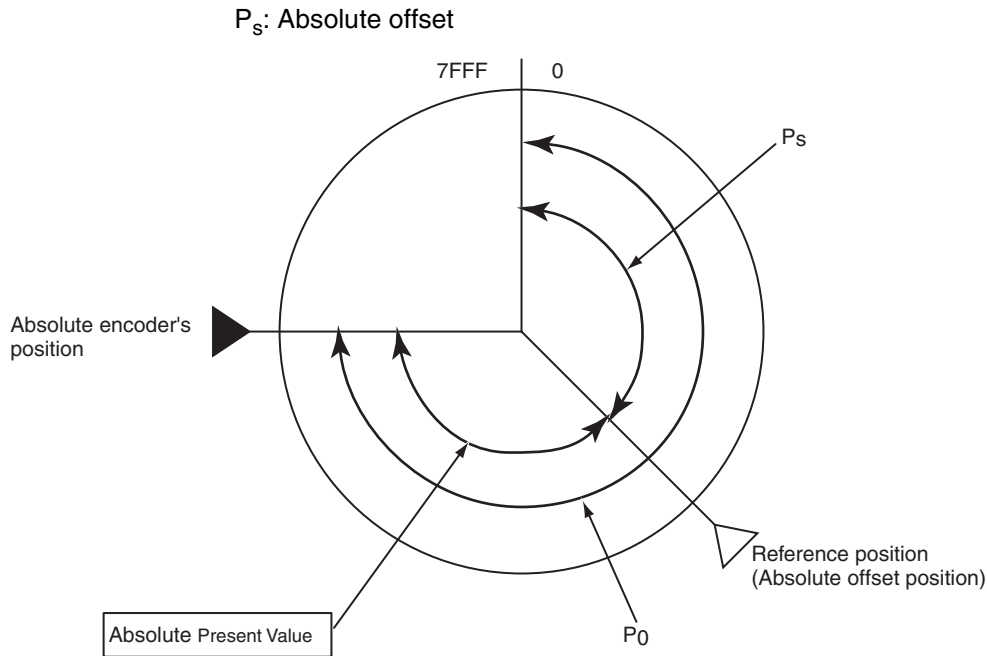

**Note** With an absolute circular counter, the absolute number of rotations present value (A604/A605) is not used; only the initial incremental pulses are used. The initial incremental pulses are the data of an amount treated as the angle from an origin.

### 7-7-7 Absolute Present Value Preset

The absolute encoder's state (absolute number of rotations PV (in A604 and A605) and the number of initial incremental pulses (in A600 and A601)) can be reflected in high-speed counter present value 1 (A600 and A601). This function is enabled by turning ON the Absolute Present Value Preset Bit (A610.06). The absolute present value is stored in High-speed Counter Present Value 1 (A600 and A601). Additionally, absolute present values vary depending on the counter operation. See 7-7-6 *Absolute Present Value* for details.

### 7-7-8 Absolute Offset Preset

The present value to be defined as an origin is obtained from the absolute number of rotations present value (A604 and A605) at the time and the number of initial incremental pulses. The value can be stored in the absolute offset (System Setup parameter). The value read from an absolute encoder at the time is defined as a machine (application) origin. This function is executed by turning ON the Absolute Offset Preset Bit (A610.05).

### 7-7-9 Related Areas

#### System Setup

Tab page	Function		Details	Time when setting becomes effective
Pulse Input	Counter 1	Pulse input mode	0 hex: Phase differential x1 1 hex: Phase differential x2 2 hex: Phase differential x4 3 hex: Increment/decrement pulse input 4 hex: Pulse + direction	At power ON
		Counter reset method	0 hex: Software reset 1 hex: Phase Z and software reset	
		Counting Speed	0 hex: 50 kHz 1 hex: 500 kHz	
		Counter operation	0 hex: Linear counter 1 hex: Circular counter 2 hex: Absolute linear (CW-) 3 hex: Absolute circular 4 hex: Absolute linear (CW+)	
		Counter data display	0 hex: Do not monitor 1 hex: Counter movements (mode 1) 2 hex: Frequency measurement (mode 2) <b>Note</b> Frequency measurement can be set for counter 1 only.	
		Sampling time (for mode 1)	Sets the sampling time when the high-speed counter PV is being measured (mode 1).  0000 hex: Cycle time 0001 to 270F hex: 1 to 9,999 ms (1-ms units) <b>Note</b> This setting is used only when the Counter Data Display parameter is set to 1 hex (mode 1).	
	Counter 2	Pulse input mode	The counter 2 parameters have the same functions as the parameters for counter 1, above.  <b>Note</b> The Counter Data Display parameter cannot be set to frequency measurement (2 hex).	
		Counter reset method		
		Counting Speed		
		Counter operation		
		Counter data display		
		Sampling time (for mode 1)		

Tab page	Function		Details	Time when setting becomes effective
Pulse input	Counter 1	Max. circular value	When the counter operation is set to circular counter, this parameter sets the maximum value in the circular counter. Setting range: 0000 0001 to FFFF FFFF hex	At power ON
		Absolute encoder resolution (Number of input pulses per encoder revolution)	0000 0001 to 0000 FFFF hex <b>Note</b> Set the resolution considering the Servo Driver's encoder dividing rate and the Motion Control Module's pulse input multiplier setting. Example: Set the resolution to FA0 (4,000) when the Servo Driver's rate is 1,000 and the Motion Control Module's multiplier is ×4.	
	Counter 2	Max. circular value	The counter 2 parameters have the same functions as the parameters for counter 1, above.	
		Absolute encoder resolution (Number of input pulses per encoder revolution)		
	Counter 1	Absolute offset	Setting range: 8000 0000 to 7FFF FFFF hex This is the origin of the application when using an absolute encoder.	Always
	Counter 2	Absolute offset	The counter 2 offset has the same function as the counter 1 offset, above.	

**Auxiliary Area**

Word	Bits	Function		Details	Controlled by
A600	00 to 15	High-speed Counter 1 PV		Counter range: 8000 0000 to 7FFF FFFF hex (8 digits hexadecimal)	Motion Control Module
A601	00 to 15				
A602	00 to 15	High-speed Counter 2 PV		<b>Note</b> In Linear Counter Mode, high-speed counter PVs are checked for overflow and underflow errors when the PVs are read (at built-in I/O refresh for the Module).	
A603	00 to 15				
A604 and A605	00 to 15	High-speed Counter 1	Counter operation • Absolute linear (CW-) • Absolute circular • Absolute linear (CW+)	Absolute No. of rotations PV Multi-turn data (PV read from encoder) input to the Motion Control Module is stored here when SEN signal is input to Servo Driver. 8000 0000 to 7FFF FFFF hex (8-digit hexadecimal)	Motion Control Module

Word	Bits	Function		Details	Controlled by	
A606 and A607	00 to 15	High-speed Counter 2	Counter operation • Absolute linear (CW-) • Absolute circular • Absolute linear (CW+)	Absolute No. of rotations PV	The same as for high-speed counter 1, except that the high-speed counter frequency measurement cannot be performed.	Motion Control Module
A608	04	High-speed Counter 1 Status	Absolute No. of Rotations Read Error Flag	OFF: No error ON: Error occurred	Motion Control Module	
	05		Absolute No. of Rotations Read Completed Flag	OFF: Not reading or reading ON: Reading completed (This is set at the completion of receiving serial data on No. of rotations.)		
	12		Absolute Offset Preset Error Flag	An error occurred when storing the absolute offset in the System Setup parameter area.		
A609	04	High-speed Counter 2 Status	Absolute No. of rotations read error	These flags have the same functions as the ones for High-speed Counter 1 Status, above.	Motion Control Module	
	05		Absolute No. of rotations read completed			
	12		Absolute offset preset error			
A610	05	High-speed Counter 1 Command	Absolute offset preset	OFF: No preset OFF to ON: Offset obtained from multi-turn data from Servo Driver and the No. of initial incremental pulses are stored as the absolute offset. When defining machine origin, difference between machine and encoder's origins is preset as the absolute offset.	Motion Control Module	
	06		Absolute PV preset	OFF: Absolute PV preset invalid OFF to ON: At this point, the absolute PV is stored in high-speed counter PV 1 (A600 and A601). <b>Note</b> Refer to 7-7-6 <i>Absolute Present Value</i> for details on the absolute PV.		
	07		Absolute No. of rotations read	OFF: No. of rotations data read from Servo Driver invalid ON: At the rising edge of the signal, SEN is output to Servo Driver, and multi-turn data is received from the phase A input.		
A611	05	High-speed Counter 2 Command	Absolute Offset Preset	These control bits have the same functions as the ones for High-speed Counter 1 Command, above.	Motion Control Module	
	06		Absolute PV Preset			
	07		Absolute No. of Rotations Read			



## 7-7-10 Overview of Absolute Encoder Output Data Acquire

### Behavior of the Servo Driver Compatible with an Absolute Encoder

The SEN signal being turned ON, the Servo Driver behaves in the following manner:

- 1,2,3...
1. The Servo Driver transmits the state of the absolute encoder when the SEN signal is turned ON.  
The operation proceeds in the following order:
    - a. Transmits the multi-turn data (how many revolutions the axis of the rotary encoder made) with the serial communications.
    - b. Transmits the initial incremental pulse (difference between present position and origin) with phase differential pulse output.
  2. After transmitting the absolute value data, transmits the pulse train corresponding to the rotational displacement. (Transmits the same pulse as an incremental encoder)

### Absolute Encoder Output Data Acquiring Method

Use the following procedure to read the absolute encoder output data from a Servo Driver to the Motion Control Module:

#### Step 1 (Required): Setting

##### Setting the Pulse Input Method

Set the pulse input method in the System Setup. Select one of the following 5 methods:

Phase differential  $\times 1$ ,  $\times 2$ , or  $\times 4$ , increment/decrement pulse input, or pulse + direction. Set the pulse input method to a phase differential input.

##### Setting the Input Pulse Counting Speed

Set the input pulse counting speed to 500 kHz. To do so, set the input pulse counting speed to 500 kHz in the System Setup.

##### Setting the Counter Operation

Set the Counter 1 Counter operation in the System Setup. Select one of the following three counter operations for counting the encoder output.

- Absolute linear (CW-) counter
- Absolute linear (CW+) counter
- Absolute circular counter

Be sure to set the System Setup's Counter 1 Counter operation so that it agrees with the Servo Driver's reverse rotation mode setting.

##### Setting the Absolute Encoder Resolution

Set absolute encoder resolution, which is the number of pulses received from the Servo Driver for each revolution of the encoder.

Consider both the Servo Driver's encoder dividing rate setting and the Motion Control Module's pulse input multiplier setting (with the System Setup's pulse input method setting). For example, set the resolution to FA0 (4,000) when the Servo Driver's rate is 1,000 and the Motion Control Module's multiplier is  $\times 4$ .

#### Step 2 (Required): Acquiring the Encoder Status when the SEN Signal is Turned ON

Turn ON the Absolute Number of Rotations Read Bit (A610.07) from the ladder program. At this point, the SEN signal will go ON (high level). Leave the SEN signal ON during operation, just like the RUN signal.

After a short time has passed to allow the Servo Driver's output to stabilize, turn ON the High-speed Counter Start Bit (A610.00) from the ladder program. The encoder's status (multi-turn data), which was acquired when the SEN signal was turned ON, is received as serial data. After the multi-turn data has been received through serial communications, the Absolute Number of Rotations Read Completed Flag (A608.05) will go ON. If a reception error occurs at this point, the Absolute Number of Rotations Read Completed Flag (A608.05) and Absolute Number of Rotations Read Error Flag (A608.04) will go ON and the received data will be discarded.

**Step 3 (as Needed): Origin Compensation (Absolute Offset Preset)**

When necessary, the absolute offset preset function can be used to set encoder's present position as the origin.

**Use the absolute offset preset function to store the present value that will be defined as an origin as the absolute offset; the present value is computed from the Absolute Number of Rotations PV (A604 and A605) and the Number of Initial Incremental Pulses (A600 and A601).**

To use the absolute offset preset function, turn ON the Absolute Offset Preset Bit (A610.05).

**Note** When performing origin compensation, set the absolute offset to 0 before starting the origin compensation operation. Use the CX-Programmer's System Setup to set the absolute offset to 0.

To use the absolute offset preset function, wait 30 to 62.5 ms after the Absolute Number of Rotations Read Completed Flag (A608.05) is turned ON and then toggle (turn ON and then OFF) the Absolute Offset Preset Bit (A610.05).

**Note** Be sure to perform the absolute offset preset operation before starting normal Servo Driver pulse outputs. The Absolute Offset Preset Bit's ON timing depends on encoder's resolution, etc. Adjust as needed corresponding to the system.

**Step 4 (Required): Absolute Present Value Preset**

**Use the absolute present value preset function to store the absolute present value in high-speed counter PV 1 (A600 and A601).**

To use the absolute present value preset function, toggle (turn ON and then OFF) the Absolute PV Preset Bit (A610.06).

**Step 5 (Required): Operating Command to Servo Driver**

Turn ON the RUN Signal Output Bit (Servo Lock). Doing so will cause the Servo Driver to start operating. At the same time, the Motion Control Module will start receiving pulse trains and counting the number of pulses corresponding to Servo Driver's rotational displacement.

**Step 6 (Required): Stopping Servo Driver**

Turn OFF the RUN Signal Output Bit (Servo Lock). Doing so will stop the Servo Driver. In addition, turn OFF the Absolute Number of Rotations Read Bit (A610.07) and High-speed Counter Start Bit (A610.00). When these bits are OFF, the Motion Control Module will stop counting the pulse trains.

### 7-7-11 Timing Chart of the Functions for Servo Drivers Compatible with Absolute Encoders

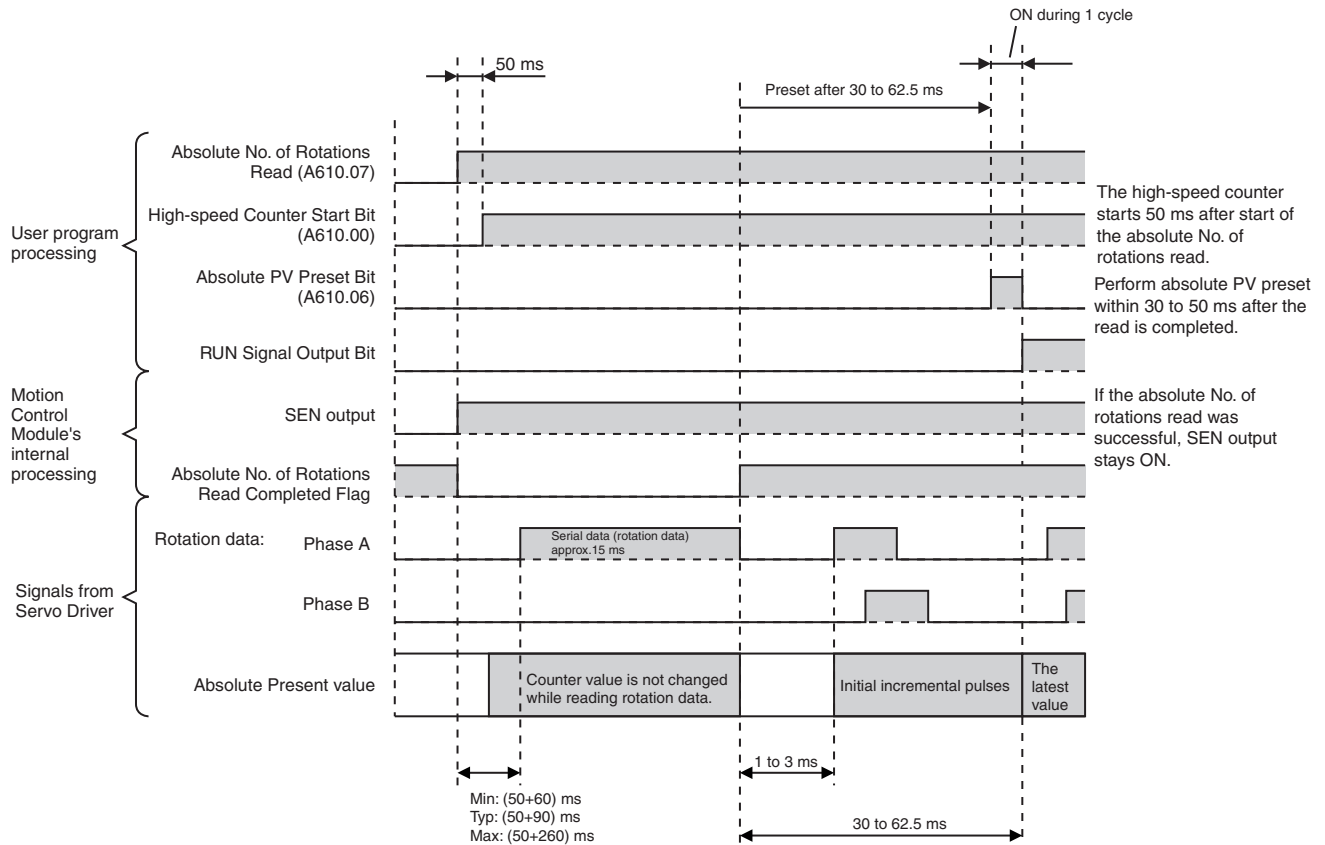

### 7-7-12 Sample Programs (Connecting an OMRON W-series Servo Driver)

#### Program Description

- 1,2,3...
1. With the Motion Control Module set to MONITOR mode, turning ON CIO 0000.01 (absolute origin define) presets the absolute origin as the absolute offset.
  2. With the Motion Control Module set to MONITOR mode, turning ON CIO 0000.00 (absolute servo operation start) presets the absolute present value in A600 and A601.

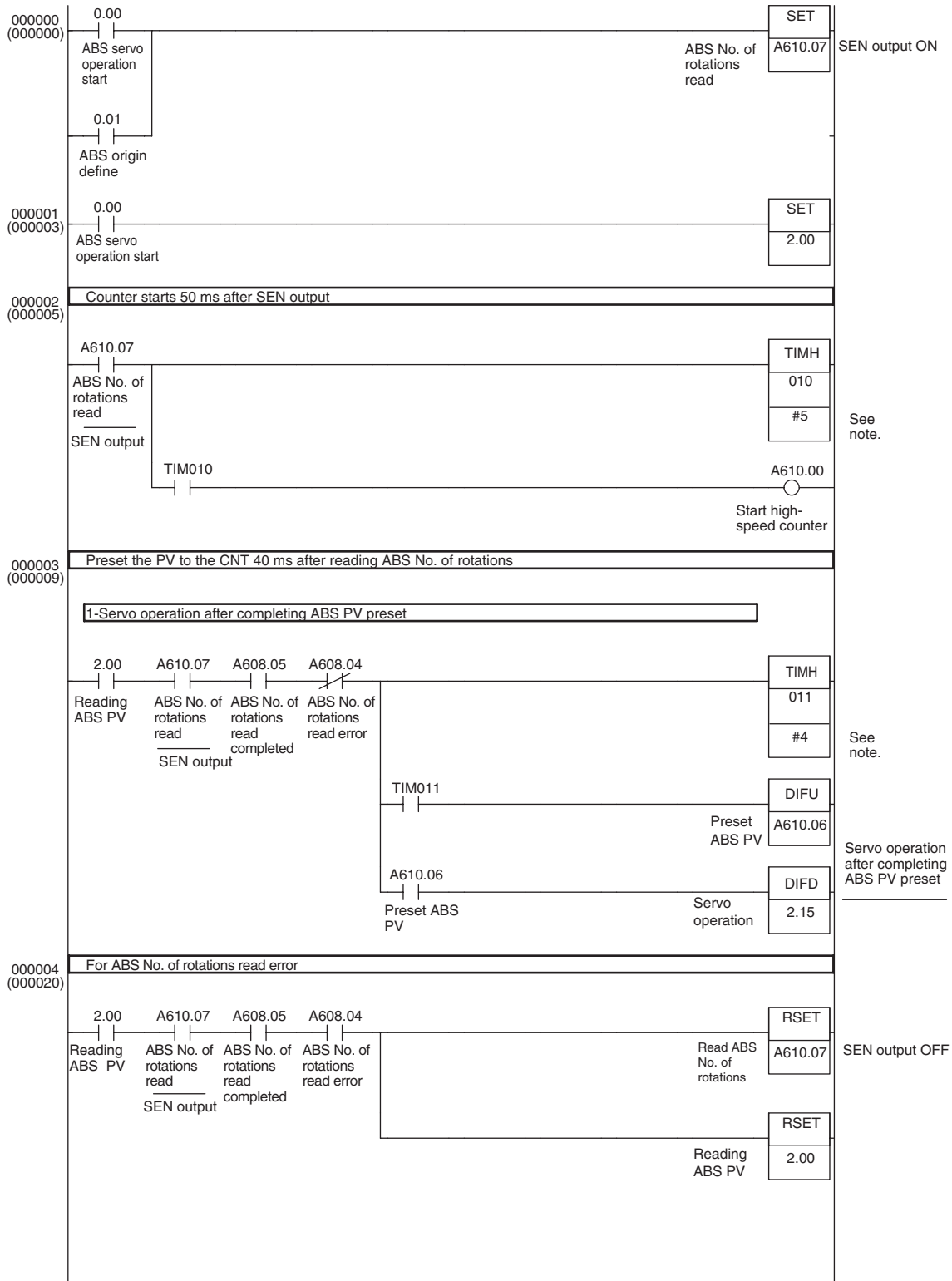

**Note** Adjust the timer value of TIMH(15) instruction (10 ms timer) to match to the system requirements (such as the absolute encoder's resolution setting). When more precision is required, use the TMHH(540) instruction (1 ms timer).

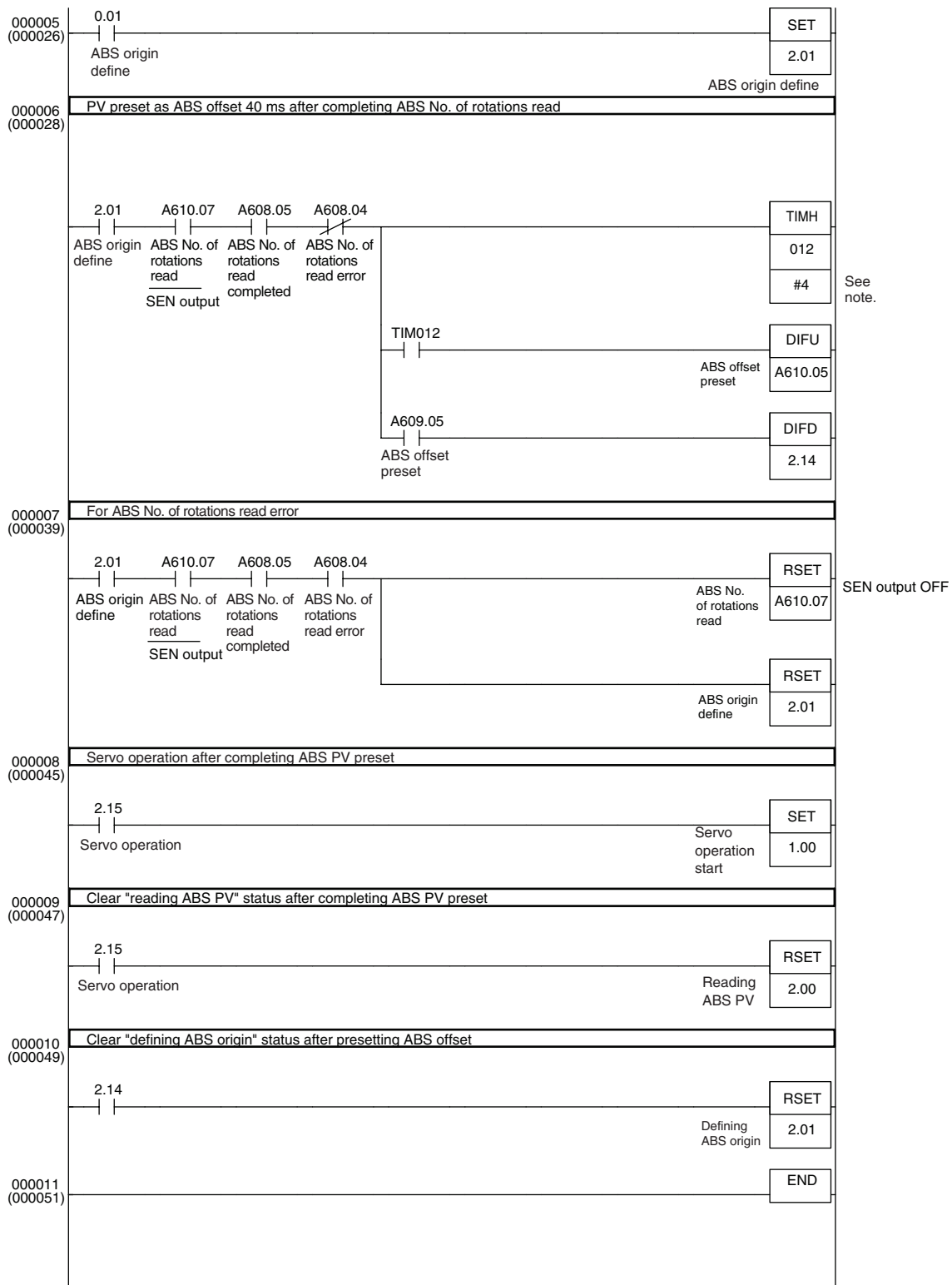

**Note** Adjust the timer value of TIMH(15) instruction (10 ms timer) to match the system requirements (such as the absolute encoder's resolution setting). When more precision is required, use TMHH(540) instruction (1 ms timer).

## 7-8 Virtual Pulse Output Function

### 7-8-1 Applicable Models

Model	Functions
FQM1-MMP21	Motion Control Module for Pulse I/O
FQM1-MMA21	Motion Control Module for Analog I/O
FQM1-CM001	Coordinator Module

### 7-8-2 Overview

The AXIS instruction allows the execution of virtual pulse output with trapezoidal acceleration/deceleration.

The AXIS instruction executes the pulse output with trapezoidal acceleration/deceleration internally. At the same time, AXIS internally integrates (counts) the number of pulses (area) in the trapezoid.

With this function, the internal pulse count can be used in various applications as a virtual axis position.

#### Example 1: Position/Speed Control Using a Virtual Axis (Electronic Cam Operation)

The internal pulse count can be treated as a virtual axis in order to perform electronic cam operation (position and speed control based on the virtual axis angle) with curve approximation on the real axis operation using the positions of the virtual axis as reference.

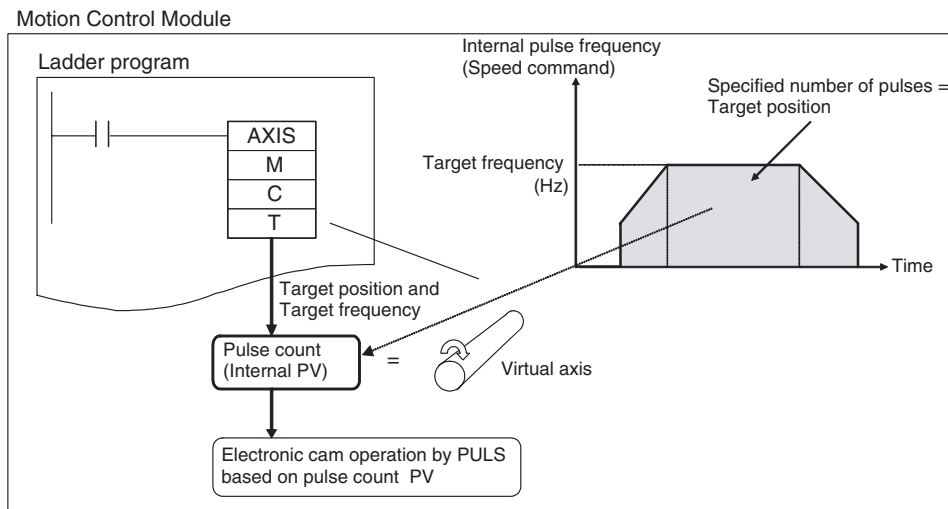

#### Example 2: Locus Control Using a Virtual Axis (2-axis Synchronous Control)

If internal pulse counts are treated as virtual reference axes, a synchronous control operation such as elliptical locus control can be performed by executing synchronous output control (electronic cam operation) simultaneously on two pulse outputs using the position and speed of the virtual axis.

#### Example 3: Semi-closed Loop Position Control with an Analog-input Servo Driver

Semi-closed loop positioning can be performed with an analog-input Servo Driver by creating a ladder program routine that controls an error counter based on the internal pulse count and the feedback signal from the Servo Driver.

### 7-8-3 AXIS Instruction (For Virtual Pulse Outputs)

#### Overview

The AXIS instruction is used to generate a virtual pulse output with trapezoidal acceleration/deceleration.

The operands for the AXIS instruction are a target position specified in pulses or as an absolute position, and a target speed specified in pulses/s (Hz). While the AXIS instruction's input condition is ON, it internally generates the specified number of pulses and integrates (counts) the number of pulses (area) in the trapezoid.

#### Operands

AXIS	
M	M: Mode specifier
C	C: Calculation cycle
T	T: First word of setting table

#### M (Mode Specifier)

Sets the output mode.

- #0000: Relative mode
- #0001: Absolute mode

#### C (Calculation Cycle)

Sets the calculation cycle.

- #0000: 2 ms calculation cycle
- #0001: 1 ms calculation cycle
- #0002: 0.5 ms calculation cycle

#### T (First Word of Setting Table)

Address	Name	Description	Setting range	Set/monitored	
T	Internal pulse count (8-digit hexadecimal)	The present value of internal pulse counter is stored here.	Relative mode: 0000 0000 to FFFF FFFF	Monitored (Read)	
T+1			Absolute mode: 8000 0000 to 7FFF FFFF		
T+2	Bit 15	Virtual pulse output status	Indicates whether or not the virtual pulse output has started.		OFF: Pulse output stopped ON: Pulse being output
	Bit 08		Indicates the direction of virtual pulse currently being output.		OFF: CW ON: CCW
	Bit 07		Indicates whether or not the virtual pulse output is being counted.		OFF: Pulse being counted ON: Target position reached (Counting stopped)
	Bit 00		Indicates whether or not the virtual pulse output is accelerating/decelerating.	OFF: Constant speed ON: Accelerating/decelerating	
T+3 to T+4	Present speed (8-digit hexadecimal)	The frequency of the virtual pulse output is stored here.	0000 0000 to 000F 4240 hex (0 to 1 MHz in 1-Hz units)		

Address	Name	Description	Setting range	Set/ monitored
T+5 to T+6	Target position (8-digit hexadecimal)	Set the number of virtual output pulses here.	Relative mode: 0000 0000 to FFFF FFFF Absolute mode: 8000 0000 to 7FFF FFFF	Set (Read/ Write)
T+7 to T+8	Target frequency (8-digit hexadecimal)	Set the target frequency of virtual pulses here.	0000 0001 to 000F 4240 hex (0 to 1 MHz in 1-Hz units)	
T+9 to T+10	Starting frequency (8-digit hexadecimal)	Set the starting frequency of virtual pulses here.	0000 0000 to 000F 4240 hex (0 to 1 MHz in 1-Hz units)	
T+11	Acceleration rate (4-digit hexadecimal)	Set the acceleration rate of virtual pulses here.	0001 to 270F (1 to 9,999 Hz, in 1-Hz units)	
T+12	Deceleration rate (4-digit hexadecimal)	Set the deceleration rate of virtual pulses here.	0001 to 270F (1 to 9,999 Hz, in 1-Hz units)	
T+13 to T+26	Work area	Used by the system.		---

### Description

- Use the AXIS instruction with an input condition that is ON for one cycle. AXIS cannot be used as a differentiated instruction (the @ prefix is not supported).
- AXIS is executed at the rising edge of the input condition. If the input remains ON, the virtual pulse output continues until the target position is reached. Once the target position is reached, the virtual pulse output is stopped. If the input condition goes OFF during the virtual pulse output, the output stops at that point.
- The AXIS instruction's mode specifier operand (M) specifies whether the virtual pulse output operates in relative or absolute mode.
  - In relative mode, the internal pulse counter initializes the internal pulse count to 0 when AXIS is executed and starts incrementing from 0.
  - In absolute mode, the internal pulse counter retains the internal pulse count when AXIS is executed and starts incrementing or decrementing from that existing pulse count.
- The internal pulse counts are refreshed every cycle at the interval specified in the calculation cycle (2 ms, 1 ms, or 0.5 ms) on the condition that the cycle time is constant. If the specified calculation cycle time does not match the execution cycle time, the time difference between the cycles can cause an error in the count. If highly accurate pulse counts are required, use the constant cycle time function and match the execution cycle time and calculation cycle time. (Set the constant cycle time in the System Setup's Cycle Time Tab Page.)
- When trapezoidal control cannot be performed with the specified target position, target frequency, and acceleration/deceleration, AXIS will automatically compensate as follows:

The acceleration and deceleration rates will be set to the same rate (symmetrical trapezoidal control).

OR

When one-half of the specified target pulses have been output, AXIS will start decelerating the operating axis at the same rate as acceleration (symmetrical triangular control).

**Note** When the AXIS instruction's input condition goes OFF, the contents of setting table words T+2 to T+4 will be initialized to 0.



### 7-8-4 Application Example

#### Positioning or Speed Control Using a Virtual Axis

The internal pulse count can be treated as a virtual axis position in order to perform electronic cam operation on the real axis operation with simple curve approximation.

First, the AXIS instruction is executed to generate an internal pulse count. The internal pulse count is read at every cycle, that pulse count is processed with basic arithmetic operations or the APR instruction, and the result is used as a target position or target speed in the PULS(886) instruction. The PULS(886) instruction (in electronic cam control) is executed immediately after the target position or speed is calculated.

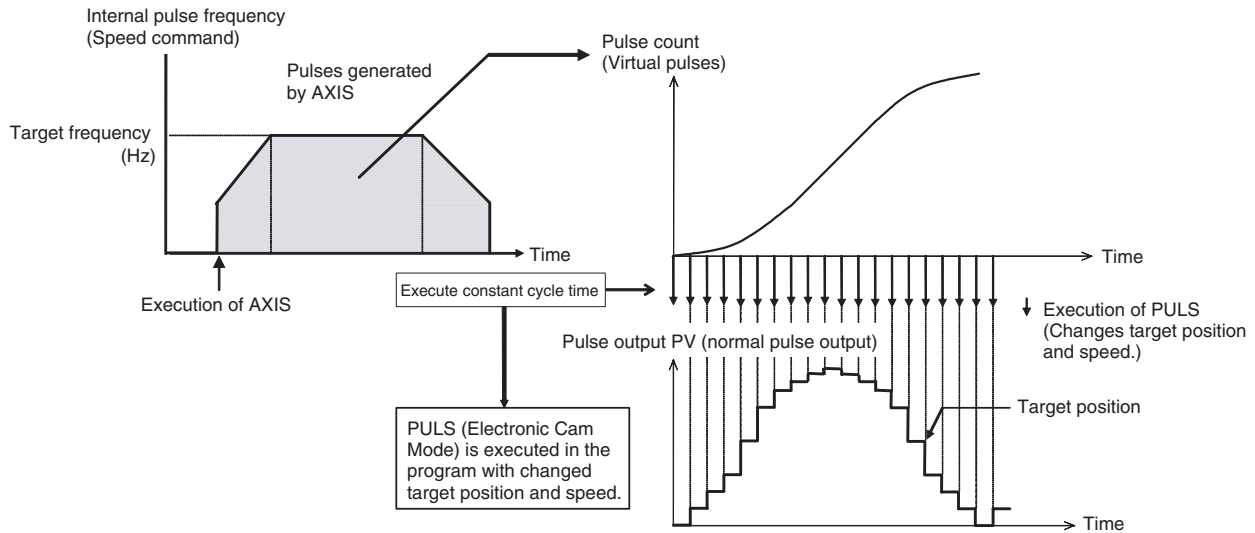

Simple locus control can be performed by executing electronic cam control simultaneously on both pulse outputs 1 and 2 using the same virtual axis as above.

## 7-9 Analog Input Functions

### 7-9-1 Applicable Models

Model	Functions
FQM1-MMA21	Motion Control Module for Analog I/O

### 7-9-2 Overview

The FQM1-MMA21 Motion Control Module can input analog input signals at high-speed (A/D conversion time: 40 μs).

One of five signal types for analog inputs can be selected: -10 to +10 V, 0 to 10 V, 0 to 5 V, 1 to 5 V, and 4 to 20 mA.

Analog input values are stored in the Motion Control Module's Auxiliary Area in A550. The stored input value is the analog input value read at END refreshing. It is also possible to adjust the analog input values.

The PRV(881) instruction can also be used to read the latest analog input value through immediate refreshing. Analog signals can be input from pressure sensors, position meters, or sensors that require high-speed input processing such as a displacement sensors/end-measuring sensors. Consequently, this function allows simple, low-cost pressure control, tension control, or other control applications requiring high-speed mechanical measurement (distortion/thickness/length).

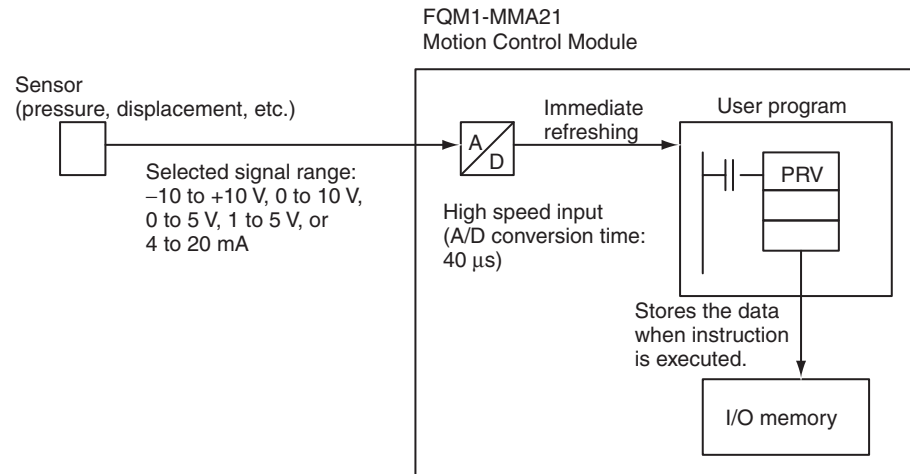

**Note** The analog input responsiveness has been set relatively high to increase the processing speed. The high responsiveness may result in input signal distortion by external noise or interference. Take steps to suppress noise if the Motion Control Module is being used in an environment with a lot of noise. When the Motion Control Module's analog input value is being used, additional noise countermeasures can be added to the program such as using END refreshing and filtering the input values with AVG instructions.

### 7-9-3 Analog Input Function Specifications

Item		Specification						
Input signals		Voltage inputs, current inputs						
No. of analog inputs		1 input						
Input signal ranges		Select one of the following input ranges in the System Setup ( <i>Analog Input/Output Tab Page – Input Setting</i> ): -10 to +10 V, 0 to 10 V, 0 to 5 V, 1 to 5 V, or 4 to 20 mA.						
A/D conversion time		40 $\mu$ s						
Input response time		1.5 ms or less (See note.)						
Resolution		-10 to +10 V: 1/16,000 (14 bits) 0 to 10 V: 1/8,000 (13 bits) 0 to 5 V: 1/4,000 (12 bits) 1 to 5 V: 1/4,000 (12 bits) 4 to 20 mA: 1/4,000 (12 bits)						
Analog input refresh method		Analog input value can be acquired by either of the following methods: <ul style="list-style-type: none"> <li>• END Refresh Read the data from A550 in the Motion Control Module's Auxiliary Area. (Data is stored in A550 during END refreshing after execution of END instruction)</li> <li>• Immediate Refresh Read the present analog input value immediately by executing the PRV(881) instruction.</li> </ul>						
Analog input value storage area		A550 of Motion Control Module's Auxiliary Area With the immediate refresh, the present analog input value can be acquired by executing the PRV(881) instruction.						
Overall accuracy		<table border="1"> <tr> <td>Voltage input:</td> <td>Current input:</td> </tr> <tr> <td><math>\pm 0.2\%</math> (<math>23 \pm 2^\circ\text{C}</math>)</td> <td><math>\pm 0.4\%</math> (<math>23 \pm 2^\circ\text{C}</math>)</td> </tr> <tr> <td><math>\pm 0.4\%</math> (0 to <math>55^\circ\text{C}</math>)</td> <td><math>\pm 0.6\%</math> (0 to <math>55^\circ\text{C}</math>)</td> </tr> </table>	Voltage input:	Current input:	$\pm 0.2\%$ ( $23 \pm 2^\circ\text{C}$ )	$\pm 0.4\%$ ( $23 \pm 2^\circ\text{C}$ )	$\pm 0.4\%$ (0 to $55^\circ\text{C}$ )	$\pm 0.6\%$ (0 to $55^\circ\text{C}$ )
Voltage input:	Current input:							
$\pm 0.2\%$ ( $23 \pm 2^\circ\text{C}$ )	$\pm 0.4\%$ ( $23 \pm 2^\circ\text{C}$ )							
$\pm 0.4\%$ (0 to $55^\circ\text{C}$ )	$\pm 0.6\%$ (0 to $55^\circ\text{C}$ )							
Function	Offset/gain adjustment	Input values can be adjusted to correct inputs suitable for the connected devices. In PROGRAM mode, specify an offset or gain value, input the analog value from the device (the value that will be corrected with the offset or gain value), and use the CX-Programmer to monitor the adjustment value in the Adjustment Value Monitor Area (A572 and A573).  It is also possible to monitor averaged offset or gain values. If averaging is required, set the number of average value samples in A574.						

**Note** The following diagram is provided as a reference example. This example shows the input response (step response) characteristics of an input when the external input signal is changed in a step pattern. In this case, the input range is -10 to +10 V.

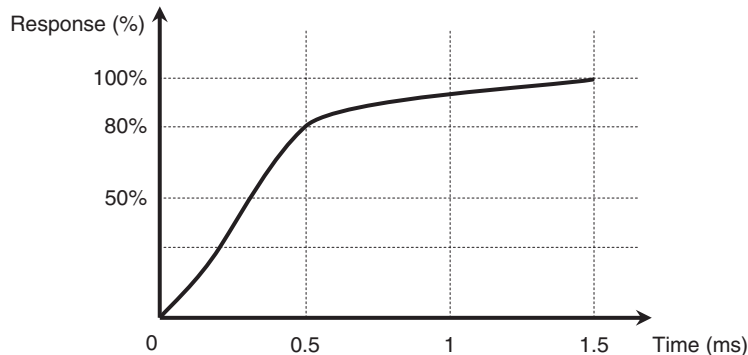

## 7-9-4 Related Areas and Settings

## System Setup

Tab page	Function		Settings	Time when setting becomes effective
Analog Input/ Output	Both inputs and outputs	Input method	0 hex: END refresh 1 hex: Immediate refresh (Refresh with PRV(881).)	At power ON and start of operation
		Output method	0 hex: END refresh (Content of A560 and A561 is output as analog output after execution of END instruction.) 1 hex: Immediate refresh (Analog output when SPED(885) or ACC(888) is executed. A560 and A561 used for monitoring.)	
	Inputs	Input range	00 hex: -10 to 10 V 01 hex: 0 to 10 V 02 hex: 1 to 5 V (4 to 20 mA) 03 hex: 0 to 5 V	At power ON
	Outputs	Output range	00 hex: -10 to 10 V 01 hex: 0 to 10 V 02 hex: 1 to 5 V 03 hex: 0 to 5 V 5A hex: Disable outputs (See note.) <b>Note</b> Outputs can be disabled to shorten the I/O refreshing time or reduce the Motion Control Module's power consumption.	At power ON
		Output stop function	0 hex: Clear outputs 1 hex: Hold outputs 2 hex: Maximum value	
	Outputs	Output range	These parameters have the same settings as output 1, above.	
Output stop function				

**Auxiliary Area**

Word	Bits	Function	Settings	Controlled by		
A550	00 to 15	Analog Input PV	Contains the value input from the analog input port (using either the END refresh or immediate refresh) in 4-digit hexadecimal. The PV range depends on the input range: • 0 to 10 V: FE70 to 20D0 hex • 0 to 5 V or 1 to 5 V: FF38 to 1068 hex • -10 to 10 V: DDA0 to 2260 hex	Motion Control Module		
A552	00	Analog Input Status	Analog Input	User Adjustment Completed	OFF: Not adjusted ON: Adjustment completed	---
	01 to 06			Reserved		
	07			Analog Sampling Started	OFF: Not started ON: Started	
	08			Factory Adjustment Data Error	OFF: No Error ON: Error (Checked at startup.)	
	09			User Adjustment Data Error	OFF: No Error ON: Error (Checked at startup.)	
	10 to 14	Reserved				
	15	Analog Input Status	Analog Input	Analog Sampling Overlap	OFF: Normal sampling ON: The next sampling operation occurred before the present sampling operation completed.	Motion Control Module
A559	01 to 15	Analog Input Status	Analog Input	Number of Samples	Indicates the number of data samples actually input since sampling started.	Motion Control Module
A560	00 to 15	Analog Output 1 Output Value	<p>When an END refresh is selected, the 4-digit hexadecimal value set here by the user is output from analog output port 1.</p> <p>When immediate refreshing is selected, the 4-digit hexadecimal value being output from analog output port 1 is stored here for monitoring. The output value range depends on the output range, as shown below.</p> <ul style="list-style-type: none"> <li>• 0 to 10 V, 0 to 5 V or 1 to 5 V: FF38 to 1068 hex</li> <li>• -10 to 10 V: EA84 to 157C hex</li> </ul> <p><b>Note</b></p> <ol style="list-style-type: none"> <li>1. Set the analog output method (END or immediate refreshing) with the System Setup's output method setting. A setting of 0 hex specifies an END refresh. This setting applies to both analog output 1 and 2.</li> <li>2. Specify the output range with the output 1 setting.</li> </ol>		With immediate refresh: Motion Control Module With END refresh: User	
A561	00 to 15	Analog Output 2 Output Value	<p>This word has the same settings as the analog output 1 output value (A560), above. (When an END refresh is selected, set the value to output from analog output port 2. When an immediate refresh is selected, the output value is stored here for monitoring.)</p> <p><b>Note</b></p> <ol style="list-style-type: none"> <li>1. Set the analog output method (END or immediate refresh) with the System Setup's output method setting. A setting of 0 hex specifies an END refresh. This setting applies to both analog output 1 and 2.</li> <li>2. Specify the output range with the output 2 setting.</li> </ol>			

Word	Bits	Function	Settings	Controlled by	
A562	00	Analog Output 1 Flags	User Adjustment Completed	Initial value is 0. Set to 1 if user performs offset/gain adjustment and Returns to factory default setting of 0 if adjustment value is cleared.	Motion Control Module
	01 to 03		Reserved	---	
	04		Operating	ON: ON while the analog output is being changed by ACC(888). OFF: Turned OFF when target value is reached.	Motion Control Module
	05 to 07		Reserved	---	
	08		Output SV Error	ON: ON when the output SV setting is outside of the allowed setting range. OFF: OFF when the output SV is within range. <b>Note</b> Only in End refresh mode	Motion Control Module
	09 to 11		Reserved	---	
	12		Factory Adjustment Value Error	ON: ON when the factory-set data stored in flash memory is invalid. OFF: OFF when the factory-set data stored in flash memory is normal.	Motion Control Module
	13		Reserved	---	
	14		User Adjustment Value Error	ON: ON when the user-set adjustment value stored in flash memory is invalid. OFF: OFF when the user-set adjustment value stored in flash memory is normal.	Motion Control Module
	15		Reserved	---	
A563	00	Analog Output 2 Flags	User Adjustment Completed	These flags have the same functions as the Analog Output 1 Flags, above.	Motion Control Module
	01 to 03		Reserved		
	04		Operating		
	05 to 07		Reserved		
	08		Output SV Error		
	09 to 11		Reserved		
	12		Factory Adjustment Value Error		
	13		Reserved		
	14		User Adjustment Value Error		
	15		Reserved		

Word	Bits	Function	Settings	Controlled by		
A570	00	Adjustment Mode Command Bits (Effective only when A575 is 5A5A hex.)	Adjustment Enable	Analog Input	OFF: Adjustment disabled. ON: Adjustment enabled. When this bit is turned from OFF to ON, the default value (offset or gain value) corresponding to the selected I/O signal range is transferred to Adjustment Value Monitor Area (A572 and A573).	User
	01			Reserved		
	02			Analog Output 1		
	03			Analog Output 2		
	04 to 06		Reserved			
	07		Adjustment Mode Specifier	OFF: Offset adjustment ON: Gain adjustment	User	
	08 to 11		Reserved			
	12		Adjustment Value Increment	While this bit is ON, the offset or gain value will be incremented by one resolution unit each 0.5 s.	Motion Control Module	
13	Adjustment Value Decrement	While this bit is ON, the offset or gain value will be decremented by one resolution unit each 0.5 s.				
14	Adjustment Value Clear	OFF to ON: Clears the adjustment data to the factory defaults.				
15	Adjustment Value Set	OFF to ON: Reads the present value in the Adjustment Value Monitor Area (A572 and A573) and saves this value to flash memory. This adjustment value will be used for the next normal mode operation.				
A571	00	Adjustment Mode Status	Adjustment Operation Error	ON when an operational error has been made, such as turning ON both the Analog Input and Analog Output 2 Adjustment Enable Bits at the same time.	Motion Control Module	
	01 to 14		Reserved			
	15		Adjustment Mode Started	ON during adjustment mode operation (when A575 contains 5A5A hex).		
A572	00 to 15	Adjustment Mode Monitor (Effective only when A575 is 5A5A hex.)	Used for Analog Input and Analog Outputs 1/2	Setting Offset Monitor	The values in these words can be overwritten directly, without using the Adjustment Value Increment/Decrement Bits.	Motion Control Module or User
A573	00 to 15			Gain Value Monitor		
A574	00 to 15		Analog Inputs	Number of Average Value Samples in Adjustment Mode	Indicates the number of values to be averaged to obtain the Offset/Gain Value Monitor values in adjustment mode. The number of samples can be set between 0000 and 0040 hex (0 to 64). Set this parameter before turning ON the Adjustment Enable Bit.	
A575	00 to 15	Adjustment Mode Password		5A5A hex: Adjustment mode enabled. Other value: Adjustment mode disabled.	User	

### 7-9-5 Applicable Instructions

#### With END Refreshing

Read the analog input PV (A550) using an instruction such as the MOV instruction.

#### With Immediate Refreshing

The data is acquired immediately with the PRV(881) instruction.

(@) PRV	
P	P: Output port (#0003: Analog input)
C	C: Control specification (#0000: Present value read)
D	D: Present value storage first word

### 7-9-6 A/D Conversion Value

When a signal is input that exceeds the allowed ranges indicated below, the conversion value will be processed as it is. However, inputting out-of-range signals may result in hardware failure or system malfunction, so do not input out-of-range signals.

**Note** If a voltage exceeding the input voltage limits is input, the conversion value will be either the upper or lower limit value.

#### Signal Range: -10 to 10 V

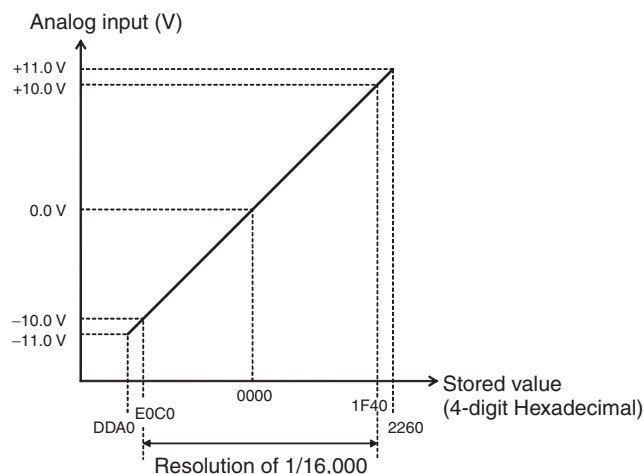

#### Signal Range: 0 to 10 V

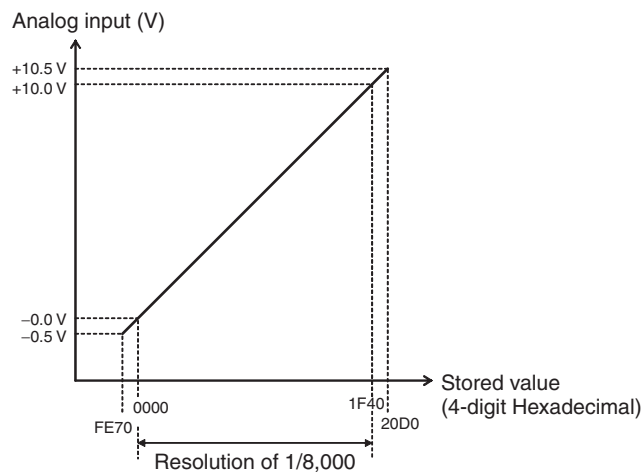



**Signal Range: 1 to 5 V and 4 to 20 mA**

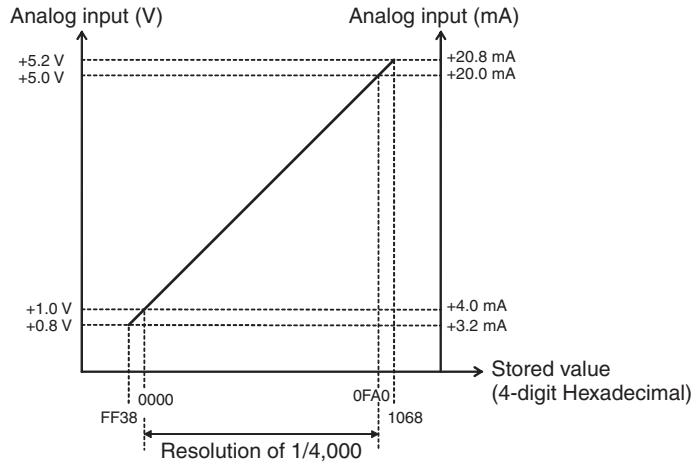

**Signal Range: 0 to 5 V**

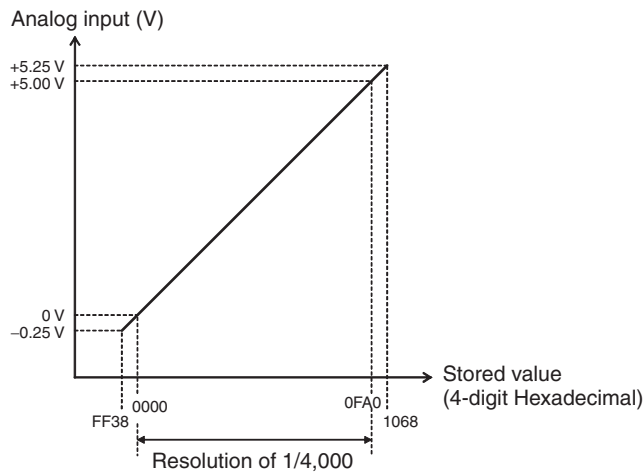

**7-9-7 High-speed Analog Sampling (FQM1-MMA21 Only)**

**Overview**

When an FQM1-MMA21 Motion Control Module is being used, the Motion Control Module can be synchronized with pulse inputs from the encoder to collect analog data.

This sampling method checks measurements in synchronization with the position, an operation which could not be performed with scheduled interrupts in earlier controllers.

When the CTBL(882) instruction is used as a high-speed analog sampling function, the Motion Control Module can start sampling analog input data at high speed when a preset counter PV is reached, and store the specified number of samples automatically in the DM Area.

This function can be used with high-speed counter 1 only.

**CTBL(882) Instruction Operation**

The CTBL(882) instruction starts a specified interrupt task when the high-speed counter PV of pulse input 1 matches a specified target value.

If the CTBL(882) instruction is executed in the interrupt task to perform high-speed analog sampling, the Motion Control Module will sample analog values at the interval (circular counter size) specified by the CTBL(882) instruction.

Once the sampling of analog input values starts, the number of values specified with the circular value (up to 32,767 samples) are stored in the DM Area beginning at the specified DM address. The sampling operation will be completed when the specified number of samples are all stored in the DM Area.

CTBL(882) with High-speed Analog Sampling Function

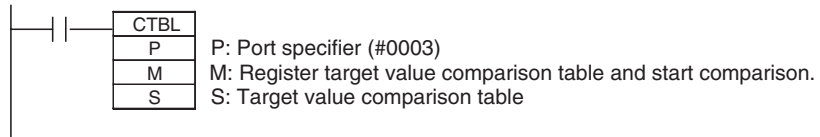

S	Target value	8-digit hex
S+1		
S+2	First word of data sample storage area (DM Area address)	0000 to 7FFF hex
S+3	Number of data samples	0000 to 7FFF hex

**Example**

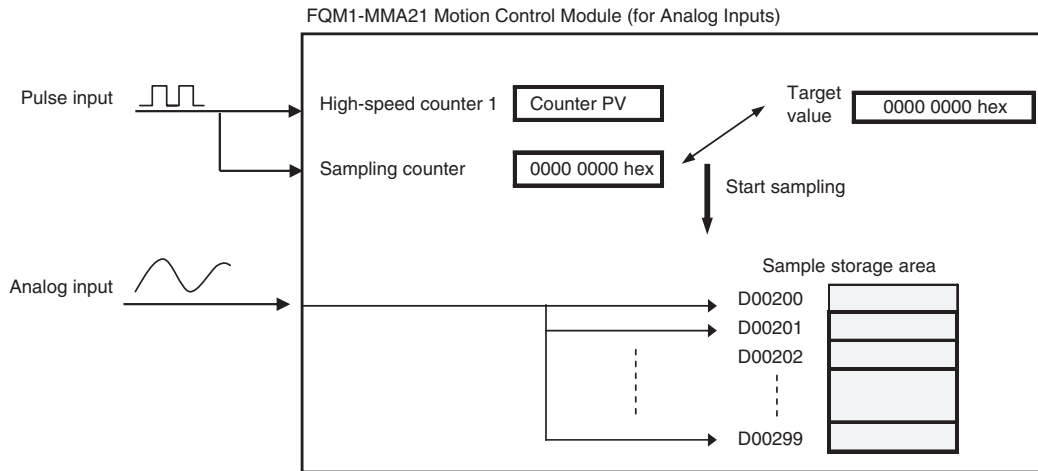
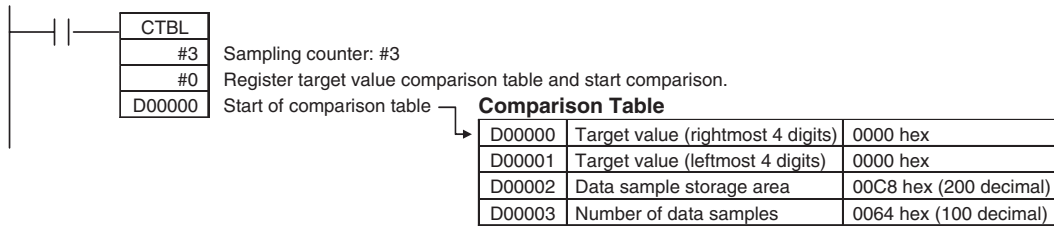

**Application Example**

**Creating Displacement Data from a Particular Workpiece Position**

In this example, operation is synchronized to the measurement position of a workpiece (such as a sheet of glass) and the Motion Control Module collects displacement data from an analog output sensor. Displacement is measured at several measurement points.

- 1,2,3...
1. When the workpiece has reached the measurement point, the CTBL(882) instruction is executed and an interrupt will be generated for the high-speed counter PV (linear counter).
  2. Another CTBL(882) instruction (using the CTBL(882) instruction's high-speed analog sampling function) is executed in that interrupt task. When the High-speed counter PV (circular counter) reaches the preset value, the Motion Control Module collects the specified number of high-speed analog input data samples from a displacement sensor.

- The high-speed analog sampling function stops when the specified number of high-speed analog input data samples have been collected.
- The following diagram shows how this method can be used to collect displacement data from a particular workpiece position.

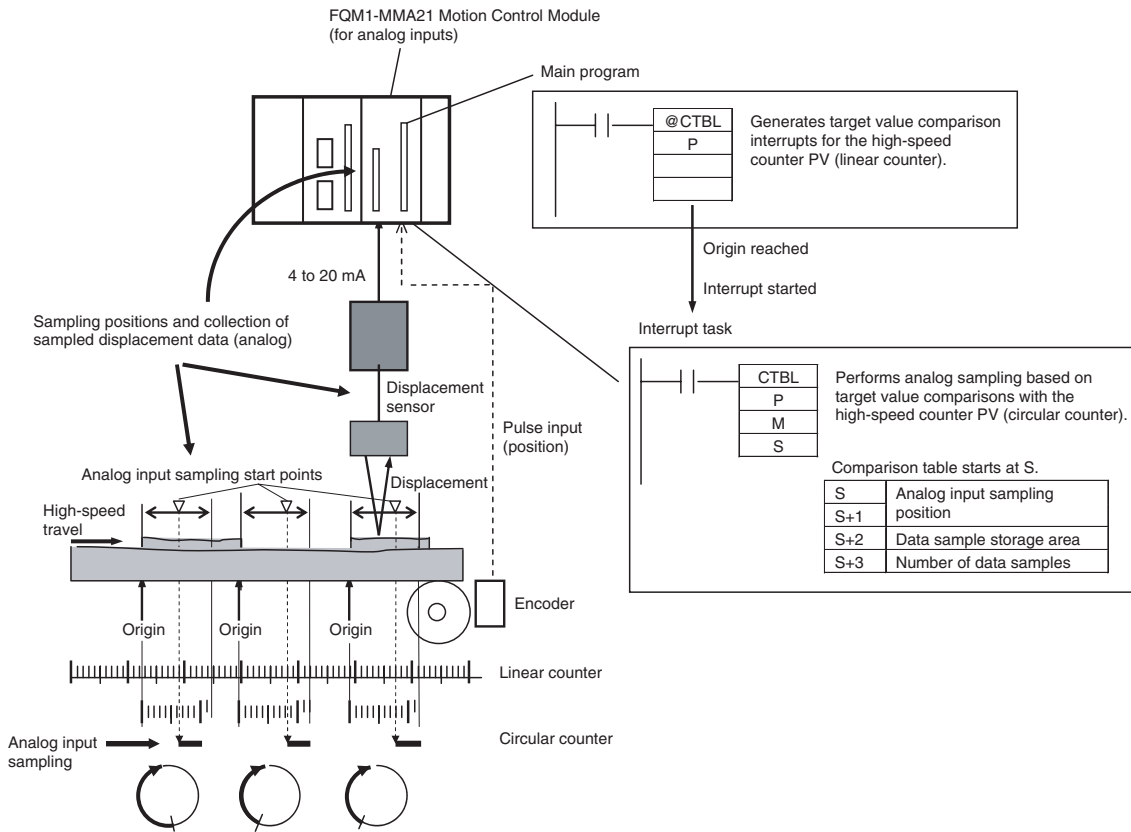

The sampled data can be processed to calculate and store the average, maximum, and minimum values in multiple ranges specified. A judgement output can also be generated.

## 7-10 Analog Outputs

### 7-10-1 Applicable Models

Model	Functions
FQM1-MMA21	Motion Control Module for Analog I/O

### 7-10-2 Outline

The FQM1-MMA21 Motion Control Module can generate analog output signals for two ports. Each output can be set independently to one of four signal types: -10 to +10 V, 0 to 10 V, 0 to 5 V, or 1 to 5 V.

Normally, the analog values stored in A560 and A561 are output cyclically during END refreshing, but the outputs values can also be immediately refreshed with the SPED(885) instruction for step-pattern outputs or the ACC(888) instruction for sloped outputs.

### 7-10-3 Analog Output Function Specifications

#### Analog Outputs

Item	Specification	
Output signals	Voltage outputs	
Number of analog outputs	2 outputs	
Output ranges	Select each output's signal range in the System Setup (Analog Input/Output Tab Page, Output 1 Setting and Output 2 Setting): -10 to 10 V, 0 to 10 V, 0 to 5 V, or 1 to 5 V	
D/A conversion time	40 $\mu$ s/output	
Resolution	-10 to 10 V: 1/10,000 (14-bit value between EC78 and 1388 hex) 0 to 10 V, 0 to 5 V, or 1 to 5 V: 1/4,000 (12-bit value between 0000 and 0FA0 hex)	
Analog output refresh method	Set the refresh timing of analog output values in the System Setup ( <i>Analog Input/Output Tab Page – Output</i> ): <ul style="list-style-type: none"> <li>• END refresh</li> <li>• Immediate refresh (executing SPED(885) or ACC(888))</li> </ul>	
	END refreshing	The values in A560 and A561 are output as the analog output 1 and 2 output values.
	Immediate refreshing by instructions	The specified analog value is output when SPED(885) or ACC(888) is executed in the program. <ul style="list-style-type: none"> <li>• SPED(885): Changes analog output value in a step pattern.</li> <li>• ACC(888): Changes analog output value with a slope. (Value changes every 2 ms.)</li> </ul> <p><b>Note</b></p> <ol style="list-style-type: none"> <li>1. Analog output values can also be controlled from interrupt subroutines.</li> <li>2. The setting in the analog output stop function determines the analog output value from startup until execution of an instruction that controls the analog output.</li> </ol>
Analog output values	<ul style="list-style-type: none"> <li>• With END refreshing, the analog output values are specified in A560 and A561.</li> <li>• With immediate refreshing by instructions, the analog output values are specified in the instruction's operands.</li> </ul> <p>-10 to 10 V EC78 to 1388 hex (-5,000 to 5,000 decimal) (resolution: 10,000) corresponding to 0% to 100% voltage (-10 to 10 V) The possible setting range is actually EA84 to 157C hex (-5,500 to 5,500 decimal) corresponding to -5% to 105% voltage (-11 to 11 V)</p> <p>0 to 10 V, 0 to 5 V, or 1 to 5 V: 0000 to 0FA0 hex (0 to 4,000 decimal) (resolution: 4,000) corresponding to 0% to 100% of the FS range. (Actually, the setting range is FF38 to 1068 (-200 to 4,200 decimal) corresponding to -5% to 105% voltage (-0.5 to 10.5 V, -0.25 to 5.25 V, or 0.8 to 5.2 V).)</p>	
Analog output value storage locations	Analog output 1: A560; Analog output 2: A561 <ul style="list-style-type: none"> <li>• With END refreshing, the contents of these words can be changed to change the analog output values that are output externally. (The actual output value may be different from the stored value if the output stop function is being used to clear the output or output the maximum value.)</li> <li>• With immediate refreshing by instructions, the value being output by SPED(885) or ACC(888) is stored in these words for monitoring when SPED(885) or ACC(888) is executed. If the hold function is being used, the values output by the hold function are stored for monitoring.</li> </ul>	
Max. external output current	2.4 mA	
Overall accuracy (See note 1.)	23 $\pm$ 2°C	$\pm$ 0.3% of FS
	0 to 55°C	$\pm$ 0.5% of FS

Item		Specification
Functions	Slope	The ACC(888) instruction can be used to change the analog output value at the following rates: -10 to 10 V: 0000 to 2AF8 hex (0 to 11,000 decimal) 0 to 10 V, 0 to 5 V, or 1 to 5 V: 0000 to 1130 hex (0 to 4,400 decimal)
	Output hold	The output stop function will clear the output, hold it at the peak value, or hold it at the current value in the following cases. <ul style="list-style-type: none"> <li>• One of the Analog Output SV Error Flags is ON. (A562.08 is the flag for output 1 and A563.08 is the flag for output 2.) (Only when end refresh is selected.)</li> <li>• A fatal error (other than a Motion Control Module WDT error or flash memory adjustment data error) occurred in the Motion Control Module. (See note 2.)</li> <li>• The other analog output is being adjusted in adjustment mode.</li> </ul>
	Offset/gain adjustment	The output values can be offset as required for the connected device. In adjustment mode, the offset or gain can be changed by turning ON the Adjustment Enable Bit (A570.00 for the analog input, A570.01 for analog output 1, or A570.02 for analog output 2), specifying the offset or gain value, and turning ON the Increment or Decrement Bit from the CX-Programmer. <ul style="list-style-type: none"> <li>• Offsets: -10 to 10 V: FE0C to 01F4 hex                          0 to 10 V, 0 to 5 V, or 1 to 5 V: FF38 to 00C8 hex</li> <li>• Gain values: -10 to 10 V: 1194 to 157C hex                          0 to 10 V, 0 to 5 V, or 1 to 5 V: 0ED8 to 1068 hex</li> </ul>

- Note**
- (1) The overall accuracy is the ratio of accuracy to the full scale.
  - (2) The following table shows the status of the analog outputs if there is a fatal error in the Motion Control Module or the Coordinator Module is in CPU standby status.

Condition	Analog output
WDT error in Motion Control Module	Output near 0 V (0 V output without offset adjustment).
<ul style="list-style-type: none"> <li>• Flash memory adjustment data error in Motion Control Module (flash memory error or adjustment data error indicated in Auxiliary Area)</li> <li>• CPU standby error in Coordinator Module</li> </ul>	
Another fatal error in the Motion Control Module (such as flash memory errors not listed above, FALS, etc.)	

If there is an error in the System Setup settings for the analog output function (Analog Input/Output), the following settings will be used.

- Output range: - 10 to 10 V
- Output stop function: Clear
- Refreshing method: END refresh

**Specified Output Values and Analog Output Signals**

**-10 to 10 V**

Analog output signal

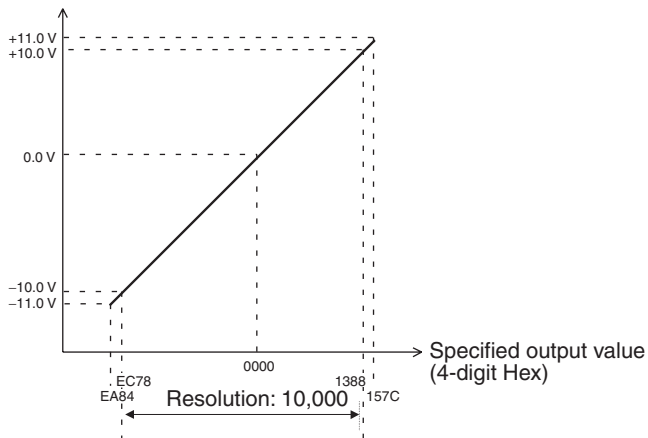

**0 to 10 V**

Analog output signal

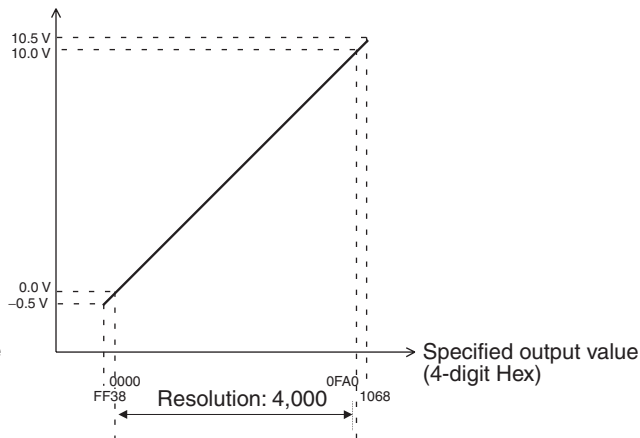

**0 to 5 V**

Analog output signal

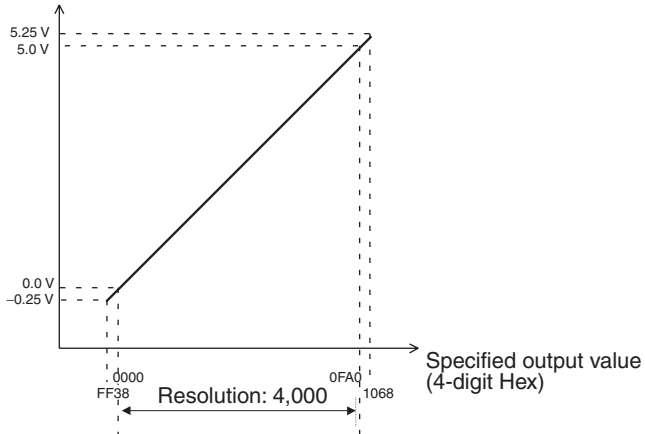

**1 to 5 V**

Analog output signal

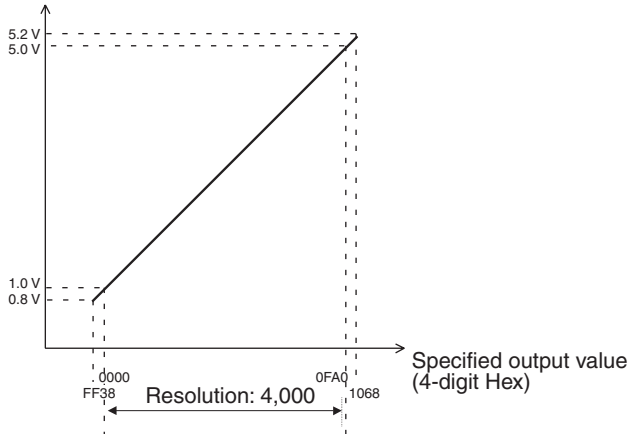

**7-10-4 Applicable Instructions**

**END Refreshing**

Set the analog output values in A560 and A561 using an instruction such as the MOV instruction.

**With Immediate Refreshing**

Outputs can be controlled with SPED(885) and ACC(888) as outlined below. SPED(885) can be used to change the output value in steps.

(@) SPED	
P	P: Port specifier
#0000	(#0001 for analog output 1 or #0002 for analog output 2)
F	M: Always #0000
	F: Analog output value

F: Analog output value

Specifies the target analog output value as a 4-digit hexadecimal value.

- 10 to 10 V	EA84 to 157C hex (-5,500 to 5,500 decimal, resolution: 11,000)
0 to 10 V, 0 to 5 V, 1 to 5 V	FF38 to 1068 hex (-200 to 4,200 decimal, resolution: 4,400)

**Note** The specified analog output value must be within the allowed range listed above. If an out-of-range output value is specified, an error will occur and it will be necessary to switch to PROGRAM mode in order to output the analog output again.

ACC(888) can be used to generate a rising or falling analog output value

(@) ACC
P
#0000
T

**P:** Port specifier  
 (#0001 for analog output 1 or #0002 for analog output 2)  
**M:** Always #0000

T = Rate of change, T+1 = Analog output target value

T = Rate of Change (4-digit hexadecimal)

T contains the rate of change (slope) per 2 ms.

-10 to 10 V	0000 to 2AF8 hex (0 to 11,000 decimal)
0 to 10 V, 0 to 5 V or 1 to 5 V	0000 to 1130 hex (0 to 4,400 decimal)

T+1 = Analog Output Target Value

T+1 is set to the target analog output value as a 4-digit hexadecimal value.

-10 to 10 V	EA84 to 157C hex (-5,500 to 5,500 decimal, resolution: 11,000)
0 to 10 V, 0 to 5 V or 1 to 5 V	FF38 to 1068 hex (-200 to 4,200 decimal, resolution: 4,400)

**Note** ACC(888) and SPED(885) cannot be used to change the analog output value while ACC(888) is generating a sloped output. Change the output value only after the target value has been reached.

### 7-10-5 Procedure

- 1,2,3...
- Determine the analog output range, number of outputs, refreshing method, and instructions that will be used.
  - Wire the analog output.
  - Make the necessary System Setup settings (output method).
    - Set the analog output range (-10 to +10 V, 0 to 10 V, 0 to 5 V, or 1 to 5 V).
    - Set the output stop function (clear, peak value, or hold).
    - Set the analog output refreshing method (END refresh or immediate refresh).
  - Create the necessary ladder programming.
    - Set the output value in A560 or A561 with an instruction such as MOV.
    - Execute SPED(885) or ACC(888).

### 7-10-6 Application Example

#### Outputting the Analog Output Value Stored in the Auxiliary Area

In this example, the Motion Control Module outputs the analog output value stored in A560 from analog output 1.

Set the following System Setup settings:

- Analog Input/Output Tab Page – Output 1: Set the output range of analog output 1 to “1 to 5 V.”
- Analog Input/Output Tab Page – Output: Set the analog output refreshing method to END refresh.

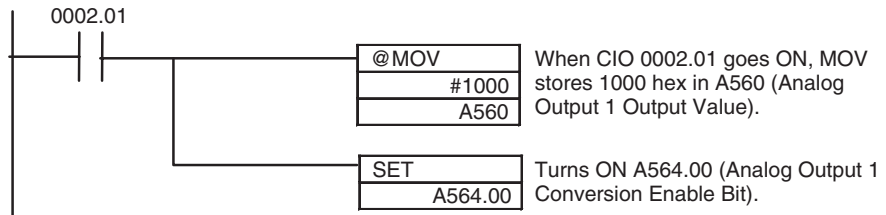

#### Outputting a Stepped Analog Output

In this example, the Motion Control Module outputs a step-pattern analog output using a particular input signal as the trigger.

Set the following System Setup settings:

- Analog Input/Output Tab Page – Output 1: Set the output range of analog output 1 to “1 to 5 V.”
- Analog Input/Output Tab Page – Output: Set the analog output refreshing method to immediate refresh.

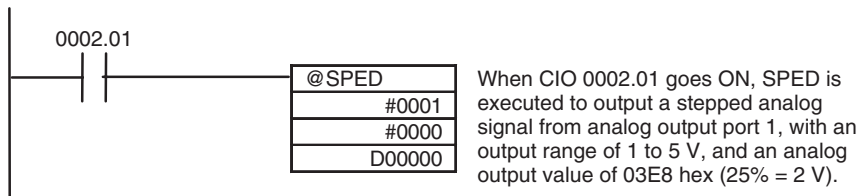

D00000 0 3 E 8 Specified analog output value = 03E8 hex (1,000 decimal = 25%)

#### Outputting a Sloped Analog Output

In this example, the Motion Control Module outputs a sloped analog output using a particular input signal as the trigger.

Set the following System Setup settings:

- Analog Input/Output Tab Page – Output 1: Set the output range of analog output 1 to “1 to 5 V.”
- Analog Input/Output Tab Page – Output: Set the analog output refreshing method to immediate refresh.

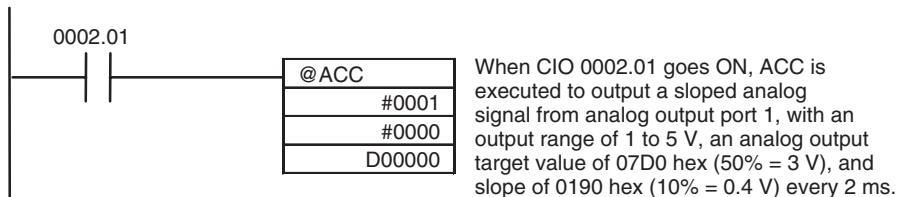

D00000 0 1 9 0 Rate of change: 0190 hex (400 decimal = 10%)  
 D00001 0 7 D 0 Specified analog output value = 07D0 hex (2,000 decimal = 50%)



# SECTION 8

## Connecting the CX-Programmer

This section explains how to connect a personal computer running the CX-Programmer to the FQM1.

8-1	CX-Programmer . . . . .	232
8-2	Connecting the CX-Programmer . . . . .	233
8-2-1	System Configuration . . . . .	233
8-2-2	CX-Programmer Connecting Cables . . . . .	236

## 8-1 CX-Programmer

Connect the CX-Programmer Support Software to the Coordinator Module to create and monitor programs for all Modules. While monitoring the ladder programs in Motion Control Modules, it is possible to input operation conditions for monitoring the I/O of the Coordinator Module, and to debug programs.

The FQM1 Patch Software is required to create the FQM1 ladder program, make System Setup settings, and monitor or debug operation.

The FQM1 Patch Software must be installed for the CX-Programmer Ver. 5.0 (Model: WS02-CXPC1-E-V50). It cannot be installed for the CX-Programmer Ver. 4.0 or earlier. To connect the FQM1 and a personal computer, use the cables shown in the following table.

Name	Model	Specifications
Programming Device Connecting Cables (for peripheral port)	CS1W-CN118	Connects a personal computer (Microsoft Windows OS). D-Sub 9-pin receptacle (converts between RS-232C and peripheral communications) (Length: 0.1 m)
	CS1W-CN226	Connects a personal computer (Microsoft Windows OS). D-Sub 9-pin (Length: 2.0 m)
	CS1W-CN626	Connects a personal computer (Microsoft Windows OS). D-Sub 9-pin (Length: 6.0 m)
Programming Device Connecting Cables (for RS-232C port)	XW2Z-200S-CV	Connects a personal computer (Microsoft Windows OS). D-Sub 9-pin (Length: 2.0 m), Static-resistant connector used.
	XW2Z-500S-CV	Connects a personal computer (Microsoft Windows OS). D-Sub 9-pin (Length: 5.0 m), Static-resistant connector used.
	XW2Z-200S-V	Connects a personal computer (Microsoft Windows OS). D-Sub 9-pin (Length: 2.0 m) (see note)
	XW2Z-500S-V	Connects a personal computer (Microsoft Windows OS). D-Sub 9-pin (Length: 5.0 m) (see note)
USB-Serial Conversion Cable	CS1W-CIF31	USB to D-Sub 9-pin conversion cable (Length: 0.5 m)

**Note** These RS-232C Connecting Cables cannot be used to connect to the CX-Programmer with Peripheral Bus communications. Connect to the CX-Programmer with Host Link (SYSMAC WAY) communications.

 **Caution** Never connect a PLC Programming Console (such as the C200H-PRO27) to the Coordinator Module's peripheral port. The FQM1 may malfunction if a PLC Programming Console is connected.

## 8-2 Connecting the CX-Programmer

### 8-2-1 System Configuration

#### Connecting a Personal Computer Running Support Software

##### Connecting to the Peripheral Port

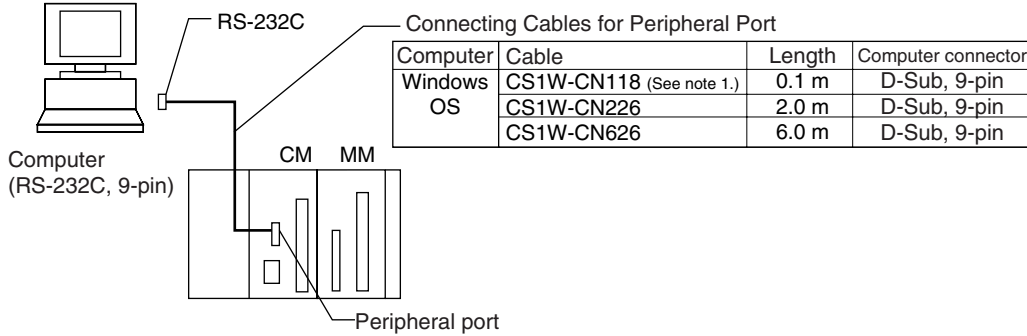

**Note 1.** The CS1W-CN118 Cable is used with an RS-232C cable to connect to the peripheral port on the Coordinator Module as shown below. Peripheral bus communications cannot be used if the CS1W-CN118 Cable is combined with an RS-232C Cable that has a model number ending in -V. In this case, Host Link (SYSMAC WAY) communications must be used.

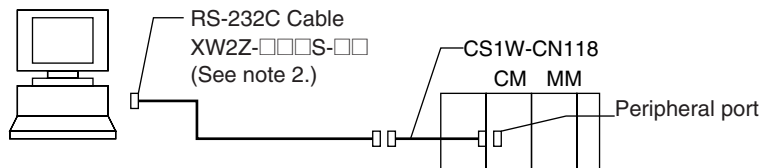

2. Host Link (SYSMAC WAY) communications cannot be used. Use peripheral bus communications.

##### Connecting to the RS-232C Port

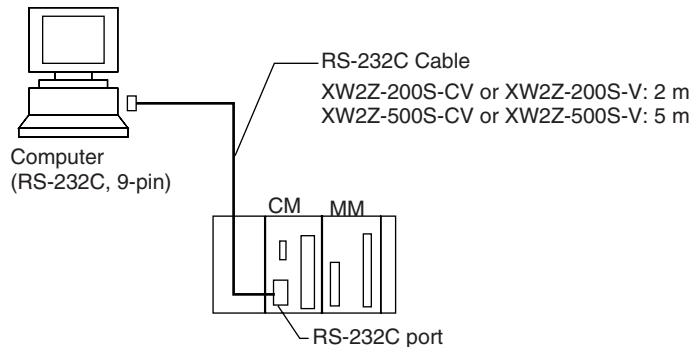

**Note** The XW2Z-200S-CV and XW2Z-500S-CV use static-resistant connectors and can be connected through peripheral bus or Host Link communications. The XW2Z-200S-V and XW2Z-500S-V, however, can only be connected through Host Link, not through peripheral bus.

#### Programming Software

OS	Name	
Microsoft Windows	CX-Programmer Version 5.0 or higher only (See note.)	CD-ROM

**Note** When the CX-Programmer is used with an FQM1, the CX-Programmer version must be Version 5.0 or higher and the FQM1 Patch Software must be installed.

**Connecting through the USB port with a USB-Serial Conversion Cable**

**Connecting to the Peripheral Port**

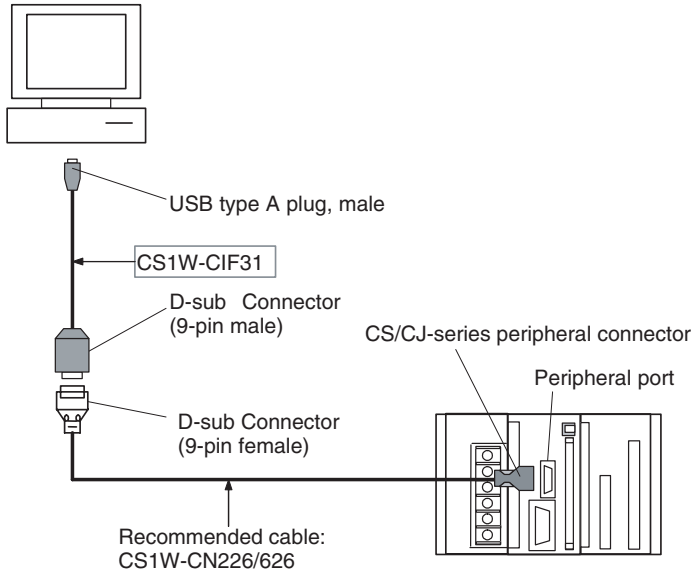
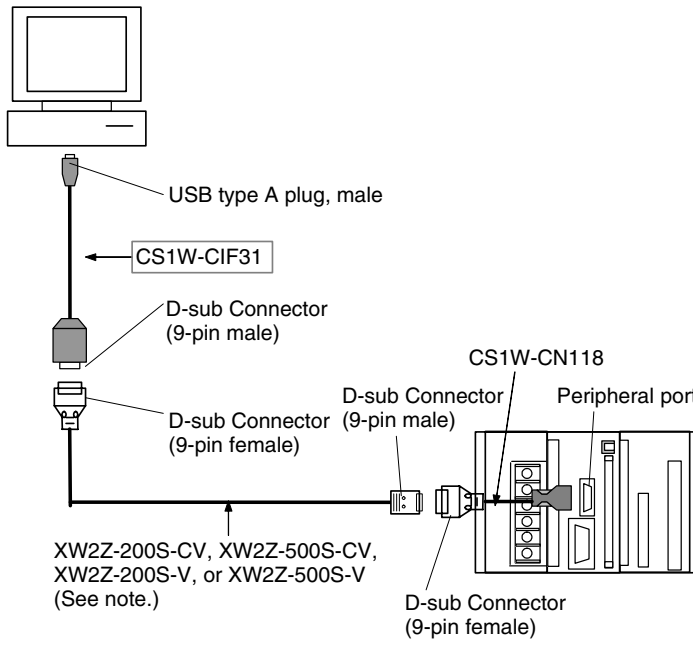
Cable	Connection Diagram
<p>Using a CS1W-CN226/626 Cable</p>	 <p>USB type A plug, male</p> <p>CS1W-CIF31</p> <p>D-sub Connector (9-pin male)</p> <p>D-sub Connector (9-pin female)</p> <p>CS/CJ-series peripheral connector</p> <p>Peripheral port</p> <p>Recommended cable: CS1W-CN226/626</p>
<p>Using an RS-232C Cable (XW2Z-200S-CV, XW2Z-500S-CV, XW2Z-200S-V, or XW2Z-500S-V)</p>	 <p>USB type A plug, male</p> <p>CS1W-CIF31</p> <p>D-sub Connector (9-pin male)</p> <p>D-sub Connector (9-pin female)</p> <p>D-sub Connector (9-pin male)</p> <p>CS1W-CN118</p> <p>D-sub Connector (9-pin female)</p> <p>Peripheral port</p> <p>XW2Z-200S-CV, XW2Z-500S-CV, XW2Z-200S-V, or XW2Z-500S-V (See note.)</p> <p><b>Note</b> The connection must be a Host Link connection.</p>

Connecting to the RS-232C Port

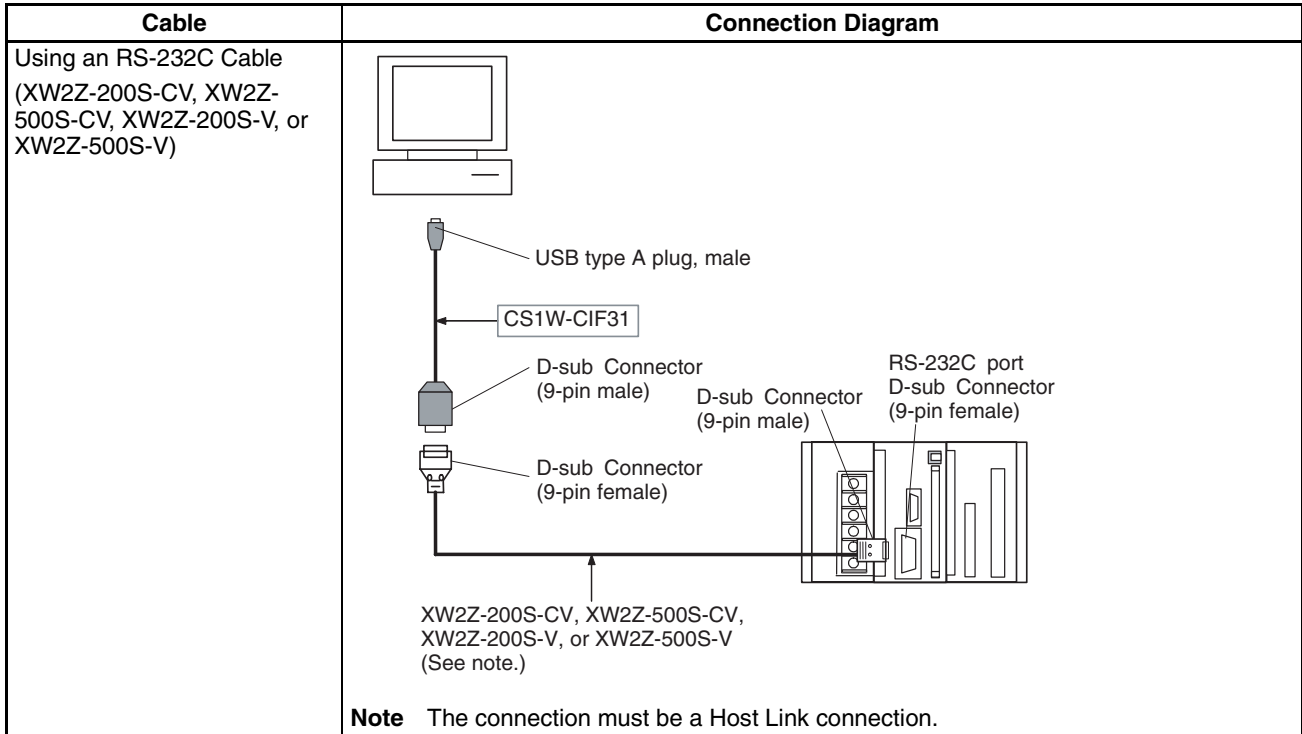

Connection Methods (Using a USB-Serial Conversion Cable)

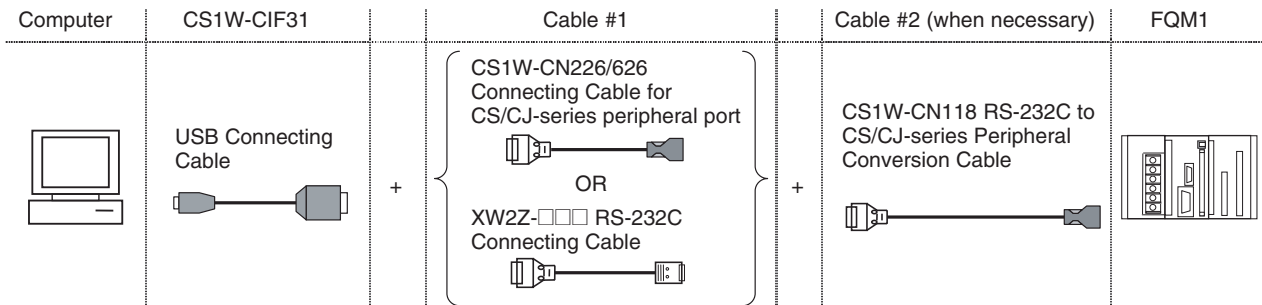

USB Connecting Cable	Cable 1			Cable 2			Port	Communications mode
	Connector	Model	Connector	Connector	Model	Connector		
CS1F-CIF31	D-Sub 9-pin female	CS1W-CN226/626 (2 or 6 m)	CS/CJ peripheral	Unnecessary			Coordinator Module peripheral	Peripheral bus (Tool bus) or Host Link
	D-Sub 9-pin female	XW2Z-200S-CV/500S-CV (2 or 5 m)	D-Sub 9-pin male	D-Sub 9-pin female	CS1W-CN118 (0.1 m)	CS/CJ peripheral		Peripheral bus (Tool bus) or Host Link
	D-Sub 9-pin female	XW2Z-200S-V/500S-V (2 or 5 m)	D-Sub 9-pin male	D-Sub 9-pin female	CS1W-CN118 (0.1 m)	CS/CJ peripheral		Host link
	D-Sub 9-pin female	XW2Z-200S-CV/500S-CV (2 or 5 m)	RS-232C D-Sub 9-pin male	Unnecessary			RS-232C D-Sub 9-pin female	Peripheral bus (Tool bus) or Host Link
	D-Sub 9-pin female	XW2Z-200S-V/500S-V (2 or 5 m)	RS-232C D-Sub 9-pin male	Unnecessary				Host link

### 8-2-2 CX-Programmer Connecting Cables

Port on Module	Computer	Port on computer	Communications mode (Network type)	Model	Length	Remarks
Built-in peripheral port	Windows OS	D-Sub 9-pin male	Peripheral bus (Tool bus) or Host Link (SYSMAC WAY)	CS1W-CN226	2.0 m	---
				CS1W-CN626	6.0 m	
Built-in RS-232C port (D-Sub 9-pin female)	Windows OS	D-Sub 9-pin male	Peripheral bus (Tool bus) or Host Link (SYSMAC WAY)	XW2Z-200S-CV	2 m	Uses static-resistant connectors
				XW2Z-500S-CV	5 m	

**Note** When connecting one of these cables to the Coordinator Module's RS-232C port, always touch a grounded metal object to discharge any electrostatic charge from the body before touching the cable connector.

The XW2Z-□□□S-CV Cables are equipped with static-resistant XM2S-0911-E Connector Hoods to improve static resistance, but we recommend discharging static build-up before touching these connectors as well.

**Caution** The OMRON Cables listed above can be used for connecting cables or an appropriate cable can be assembled. The external device or Coordinator Module itself may be damaged if a standard computer RS-232C cable is used as a connecting cable.

**Connecting an RS-232C Cable to the Peripheral Port**

The following connection configurations can be used when connecting an RS-232C cable to the Coordinator Module's peripheral port.

Port on Module	Computer	Port on computer	Communications mode (Network type)	Model	Length	Remarks
Built-in peripheral port	Windows OS	D-Sub 9-pin male	Peripheral bus (Tool bus) or Host Link (SYSMAC WAY)	CS1W-CN118 + XW2Z-200S-CV/500S-CV	0.1 m + (2 m or 5 m)	The XW2Z-□□□S-CV Cables have static-resistant connectors.
			Host link (SYSMAC WAY)	CS1W-CN118 + XW2Z-200S-V/500S-V		---

**Connecting an RS-232C Cable to the RS-232C Port**

The following connection configuration can be used to connect a personal computer to the Coordinator Module's RS-232C port with an RS-232C cable.

Port on Module	Computer	Port on computer	Communications mode (Network type)	Model	Length	Remarks
Built-in RS-232C port D-sub 9-pin female	Windows OS	D-Sub 9-pin male	Host link (SYSMAC WAY)	XW2Z-200S-V	2 m	---
				XW2Z-500S-V	5 m	

**Note** Either one of the following two serial communications modes can be used when connecting the CX-Programmer to the FQM1.

Serial communications mode	Features
Peripheral bus (Tool bus)	<p>Supports high-speed communications, so this communications mode is normally used to connect to the CX-Programmer.</p> <ul style="list-style-type: none"> <li>• Supports only a 1:1 connection.</li> <li>• When the FQM1 is connected, the CX-Programmer can recognize the baud rate and make the connection automatically.</li> </ul>
Host link (SYS-MAC WAY)	<p>This communications mode is generally used to connect to a host computer. Both 1:1 and 1:N connections are supported.</p> <ul style="list-style-type: none"> <li>• Host link communications are relatively slow compared to the peripheral bus mode.</li> <li>• The Host Link mode supports connections through modems or optical adapters, long-distance connections using RS-422A or RS-485 communications, and 1:N connections.</li> </ul>





# SECTION 9

## Error Processing

This section provides information on identifying and correcting errors that occur during FQM1 operation.

9-1	Error Log . . . . .	240
9-2	Error Processing . . . . .	241
9-2-1	Error Categories . . . . .	241
9-2-2	Error Information . . . . .	241
9-2-3	Error Codes . . . . .	242
9-2-4	Error Processing Flowchart . . . . .	243
9-2-5	Error Tables . . . . .	244
9-2-6	Power Supply Check . . . . .	249
9-2-7	Memory Error Check . . . . .	250
9-2-8	Program Error Check . . . . .	250
9-2-9	Cycle Time Overrun Error Check . . . . .	251
9-2-10	System Setup Error Check . . . . .	251
9-2-11	I/O Setting Error Check . . . . .	252
9-2-12	I/O Check . . . . .	253
9-2-13	Environmental Conditions Check . . . . .	254
9-3	Troubleshooting Problems in Modules . . . . .	254

# 9-1 Error Log

Each time that an error occurs in the FQM1, the error information is stored in the Error Log Area starting at A100. The error information includes the error code (same code stored in A400) and error contents. Up to 20 records can be stored in the Error Log.

## Errors Generated by FAL(006)/FALS(007)

In addition to system errors generated by the Coordinator Module and Motion Control Module, the FQM1 records user-defined errors generated by the FAL and FALS instructions in the ladder program. These instructions make it easier to track the operating status of the system.

A user-defined error is generated when FAL or FALS is executed in the program. The input conditions of these instructions constitute the user-defined error conditions.

The following table shows the error codes for FAL and FALS, which are stored in A400 and the first word of the error record when the instruction is executed.

Instruction	FAL numbers	Error codes
FAL	#0001 to #01FF (1 to 511 decimal)	4101 to 42FF
FALS	#0001 to #01FF (1 to 511 decimal)	C101 to C2FF

**Note** FAL generates a non-fatal error (the Coordinator and Motion Control Module continue operating). FALS generates a fatal error that stops operation.

## Error Log Structure

When more than 20 errors occur, the oldest error data (in A100 to A104) is deleted and the newest record is stored in A195 to A199.

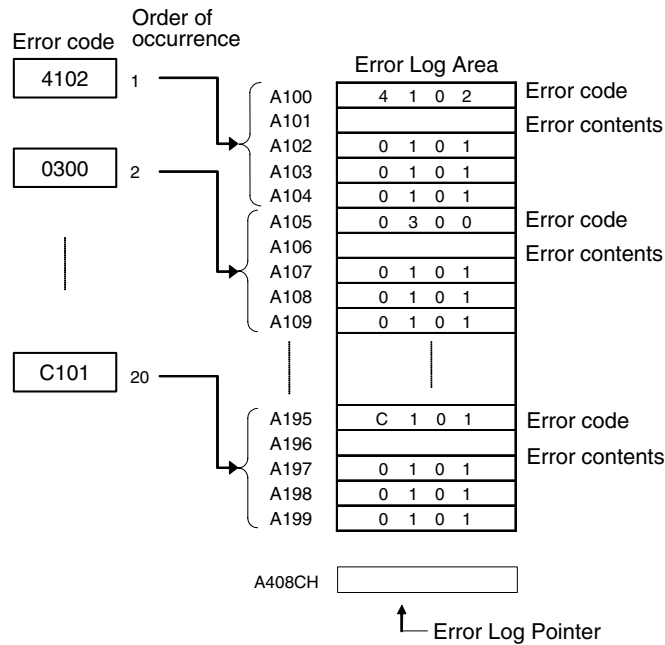

**Note** The Error Log Pointer can be reset by turning ON the Error Log Pointer Reset Bit (A500.14), effectively clearing the error log display in the CX-Programmer. The contents of the Error Log Area will not be cleared by resetting the pointer.

## 9-2 Error Processing

### 9-2-1 Error Categories

Errors in the FQM1 can be broadly divided into the following three categories.

Category	Result	Indicators			Comments
		RDY	RUN	ERR	
Standby	The FQM1 will not start operation in RUN or MONITOR mode.	OFF	OFF	OFF	This status occurs when a faulty Motion Control Module is connected.
Non-fatal Errors (including FAL)	The FQM1 will continue operating in RUN or MONITOR mode.	ON (Green)	ON (Green)	Flashing (Red)	This status indicates a non-fatal error other than a communications error.
Fatal Errors (including FALS)	The FQM1 will stop operating in RUN or MONITOR mode.	ON (Green)	OFF	ON (Red)	This status indicates a fatal error other than a power interruption. (The indicators will all be OFF when there is a power interruption.)

### 9-2-2 Error Information

There are basically four sources of information on errors that have occurred:

- The LED indicators on the front of the Coordinator and Motion Control Modules
- The Auxiliary Area Error Flags
- The Auxiliary Area Error Contents Words
- The Auxiliary Area Error Code Word

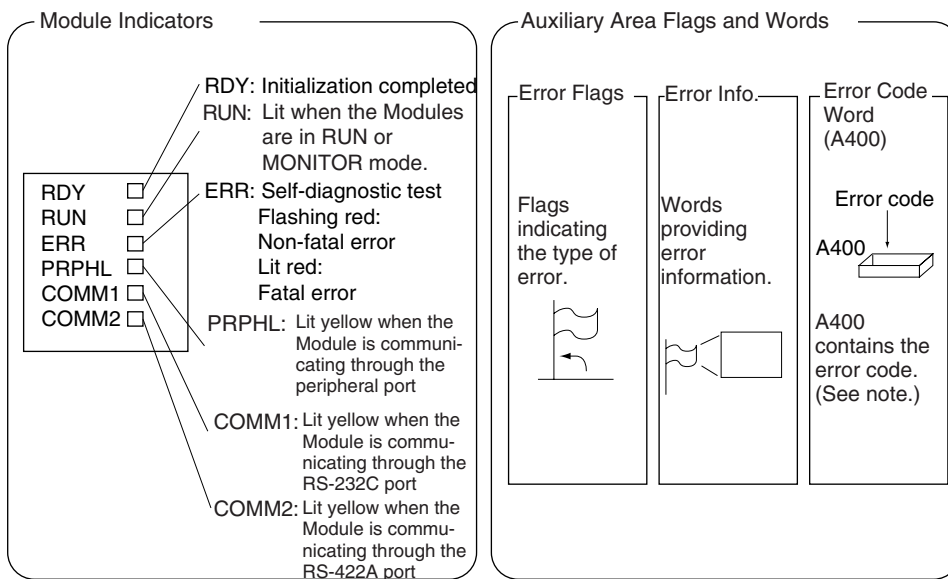

**Note** When two or more errors occur at the same time, the highest (most serious) error code will be stored in A400.

### Indicator Status and Error Conditions

The following table shows the status of the FQM1's indicators for errors that have occurred in RUN or MONITOR Mode.

Indicator	CPU error	CPU reset	CPU standby	Fatal error	Non-fatal error	Communications error		
						Peripheral	RS-232C	RS-422A
RDY	OFF	OFF	OFF	ON	ON	ON	ON	ON
RUN	OFF	OFF	OFF	OFF	ON	---	---	---

Indicator	CPU error	CPU reset	CPU standby	Fatal error	Non-fatal error	Communications error		
						Peripheral	RS-232C	RS-422A
ERR	ON	OFF	OFF	ON	Flashing	---	---	---
PRPHL	---	---	---	---	---	OFF	---	---
COMM1	---	---	---	---	---	---	OFF	---
COMM2	---	---	---	---	---	---	---	OFF

### 9-2-3 Error Codes

Classification	Error code	Error name	Page
Fatal system errors	80F1	Memory error	242
	80C0	I/O bus error	242
	80CE	No End Cover	242
	80CF	Synchronous bus error	242
	80E0	I/O setting error	242
	80F0	Program error	242
	809F	Cycle time overrun error	242
Non-fatal system errors	009B	System Setup setting error	242
	0001	Coordinator Module WDT error	242
	0006	Coordinator Module error	242
	0300	Motion Control Module WDT error	242
User-defined non-fatal errors	4101 to 42FF	FAL error (4101 to 42FF are stored for FAL numbers 001 to 511)	242
User-defined fatal errors	C101 to C2FF	FALS error (C101 to C2FF are stored for FALS numbers 001 to 511)	242

### 9-2-4 Error Processing Flowchart

Use the following flowchart as a guide for error processing with the CX-Programmer.

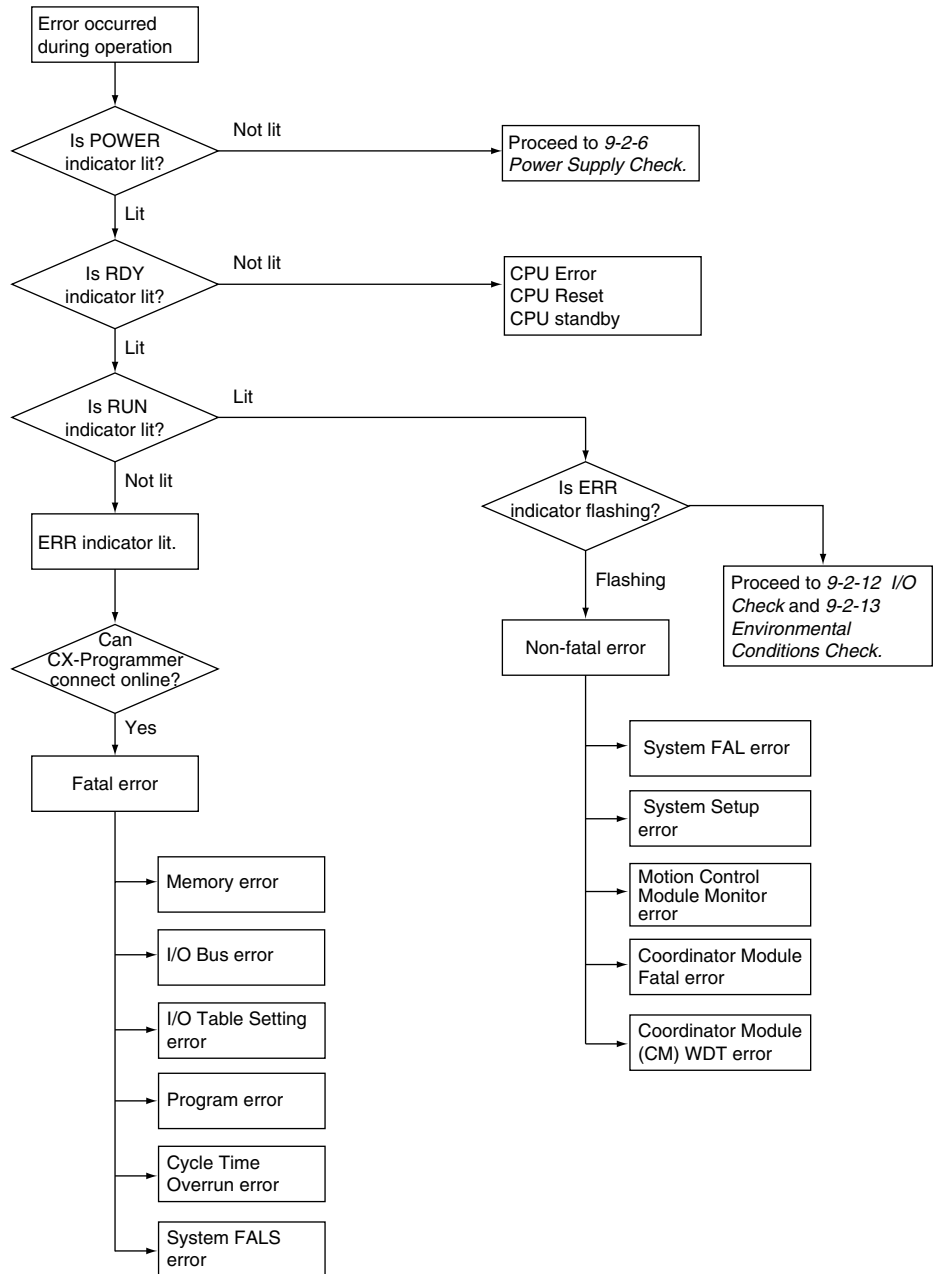

### 9-2-5 Error Tables

The following tables show the errors which can occur in the FQM1 and indicate the probable cause of the errors.

**Note** Always confirm the safety of connected equipment before turning the power supply OFF or ON.

#### CPU Errors

If the following LED indicator condition appears during operation (in RUN or MONITOR mode), it indicates that a CPU error has occurred. The CX-Programmer cannot be connected if a CPU error has occurred.

If a fatal error occurs, the RDY and ERR indicators will be lit and the RUN indicator will be OFF, but a CX-Programmer can be connected. This difference can be used to distinguish between a CPU error and other fatal errors.

Power Supply Unit Indicators	Module Indicators					
POWER	RDY	RUN	ERR	PRPHL	COMM1	COMM2
Lit	OFF	OFF	Lit	---	---	---

Operating status	Error name	Error flags in Auxiliary Area	Error code (in A400)	Error contents	Probable cause	Remedy
Stopped	CPU error	None	None	None	A WDT (watchdog timer) error occurred in a Module. (This error does not normally occur)	Turn the power OFF and restart. The Module may be damaged. Contact your OMRON representative.

#### CPU Standby

If the following LED indicator condition appears when the power is turned ON, it indicates that the FQM1 is in CPU standby status.

When the FQM1 is turned ON, cyclic servicing starts after the Coordinator Module recognizes all of the connected Motion Control Modules. Operation can be started at that point.

If the startup mode is RUN or MONITOR mode, the FQM1 will remain in standby status until all of the Motion Modules have been recognized..

Power Supply Unit Indicators	Module Indicators					
POWER	RDY	RUN	ERR	PRPHL	COMM1	COMM2
Lit	OFF	OFF	OFF	---	---	---

Operating status	Error name	Error flags in Auxiliary Area	Error code (in A400)	Error contents	Probable cause	Remedy
Stopped	CPU standby	None	None	None	A Motion Control Module has not started properly.	Replace the Motion Control Module.

#### Fatal Errors

If the following LED indicator condition appears during operation (in RUN or MONITOR mode), it indicates that a fatal error has occurred..

Power Supply Unit Indicators	Module Indicators					
POWER	RDY	RUN	ERR	PRPHL	COMM1	COMM2
Lit	Lit	OFF	Lit	---	---	---

The fatal error's error contents will be displayed in the Error Tab in the CX-Programmer's Error Window. Determine the cause of the error from the error

message and related Auxiliary Area flags/words and correct the cause of the error.

Errors are listed in order of importance. When two or more errors occur at the same time, the more serious error's error code will be recorded in A400.

The I/O memory will be cleared when a fatal error other than FALS occurs. (The I/O memory will not be cleared when FALS is executed to generate a fatal error.)

When operation is stopped, all outputs will be turned OFF. The Servo Driver that is in Servo ON state for outputs from the FQM1 will switch to Servo OFF state.

**Fatal Errors**

Error	Error code (in A400)	Auxiliary Area flag and word data	Probable cause	Possible remedy
Memory error	80F1	A401.15: Memory Error Flag A403: Memory Error Location	An error has occurred in memory. A bit in A403 will turn ON to show the location of the error as listed below.	See below.
			A403.00 ON: A checksum error has occurred in the user program memory. An illegal instruction was detected.	Check the program and correct the error.
			A403.04 ON: A checksum error has occurred in the System Setup.	Transfer the System Setup settings again.
			A403.10 ON: An error occurred in flash memory (backup memory).	Module hardware is faulty. Replace the Module.
			A403.13 ON: There is an error in the analog off-set/gain data.	Check the data and set again.
			A403.14 ON: A checksum error has occurred in the DM data stored in flash memory.	Replace the Module.
I/O Bus error	80C0 80CE 80CF	A401.14: I/O Bus Error Flag	Error has occurred in the data transfer between connected Modules or the End Cover is not connected to the right side of the FQM1.	Try turning the power OFF and ON again.  If the error persists, turn the power OFF and check connections between the Modules and the End Cover.  Check for damage to the Modules. After correcting the problem, turn the FQM1's power OFF and then ON again.
Program error	80F0	A401.09: Program Error Flag A405: Program error information	The program is incorrect. A bit in A405 will turn ON to show the error details as listed below.	Check A405 to determine the type of error that occurred. Correct the program and then clear the error.
			A405.11: No END error	Be sure that there is an END instruction at the end of the program.
			A405.15: UM overflow error The last address in UM (user program memory) has been exceeded.	Use the CX-Programmer to transfer the program again to FQM1.
			A405.13: Differentiation overflow error Too many differentiated instructions have been inserted or deleted during online editing.	After writing any changes to the program, switch to PROGRAM mode and then return to MONITOR mode to continue editing the program.
			A405.12: Task error A task error has occurred. The task specified in the MSKS instruction doesn't exist.	Check that all of the task numbers specified in the MSKS instructions have corresponding tasks. Use MSKS to mask any input interrupt task or other interrupt tasks that are not being used and that do not have programs set for them.
A405.14: Illegal instruction error The program contains an instruction that cannot be executed.	Check and correct the program.			



Error	Error code (in A400)	Auxiliary Area flag and word data	Probable cause	Possible remedy
I/O Table Setting error	80E0	A401.10: I/O Setting Error Flag	More than 5 Modules are connected.	Check whether the number of Modules is incorrect. If the number of Modules is incorrect, turn OFF the power supply and correctly connect the Modules.
Cycle Time Overrun error	809F	A401.08: Cycle Time Too Long Flag	The cycle time has exceeded the maximum cycle time (watch cycle time) set in the System Setup.	Change the program to reduce the cycle time or change the System Setup's maximum cycle time setting. One way to reduce the cycle time is by jumping parts of the program that aren't being used.
System FALS error	C101 to C2FF	A401.06: FALS Error Flag	FALS has been executed in the program. The error code in A400 will indicate the FAL number. The leftmost digit of the code will be C and the rightmost 3 digits of the code will be from 101 to 2FF hex, which correspond to FAL numbers 001 to 511.	Remove the cause of the user-defined error indicated by the FAL number.

**Non-fatal Errors**

If the following LED indicator condition appears during operation (in RUN or MONITOR mode), it indicates that a non-fatal error has occurred..

Power Supply Unit Indicators	Module Indicators					
POWER	RDY	RUN	ERR	PRPHL	COMM1	COMM2
Lit	Lit	Lit	Flashing	---	---	---

The non-fatal error's error contents will be displayed in the Error Tab in the CX-Programmer's Error Window. Determine the cause of the error from the error message and related Auxiliary Area flags/words and correct the cause of the error.

Errors are listed in order of importance. When two or more errors occur at the same time, the more serious error's error code will be recorded in A400.

**Non-fatal Errors**

Error	Error code (in A400)	Flag and word data	Probable cause	Possible remedy
System FAL error	4101 to 42FF	A402.15: FAL Error Flag	FAL has been executed in program. The error code in A400 will indicate the FAL number. The leftmost digit of the code will be 4 and the rightmost 3 digits of the code will be from 101 to 2FF hex, which correspond to FAL numbers 001 to 511.	Remove the cause of the user-defined error indicated by the FAL number.
System Setup error	009B	A402.10: System Setup Error Flag A409: System Setup Error Location	There is a setting error in the System Setup. The location of the error is written to A409.	Set the correct value in the System Setup.
Motion Control Module Monitoring error	0300	A402.05: Motion Control Module Monitoring Error Flag	An error occurred during cyclic refreshing with the Motion Control Module.	Turn the power OFF and ON again.

Error	Error code (in A400)	Flag and word data	Probable cause	Possible remedy
Coordinator Module Fatal error	0006	A402.14: Coordinator Module Fatal Error Flag	A fatal error occurred in the Coordinator Module.	Remove the cause of the error in the Coordinator Module and then clear the error.
Coordinator Module WDT error	0001	A402.13: Coordinator Module WDT Error Flag	A watchdog timer error occurred in the Coordinator Module.	Turn the power OFF and ON again.

**Other Errors**

LED indicator status	Error	Error code (A400)	Flag and word data	Probable cause	Possible remedy																
<table border="1"> <tr> <td>Power Supply Unit</td> <td>POWER</td> <td>Lit</td> </tr> <tr> <td rowspan="6">Coordinator Module</td> <td>RDY</td> <td>Lit</td> </tr> <tr> <td>RUN</td> <td>Lit</td> </tr> <tr> <td>ERR</td> <td>---</td> </tr> <tr> <td>PRPHL</td> <td>OFF</td> </tr> <tr> <td>COMM1</td> <td>---</td> </tr> <tr> <td>COMM2</td> <td>---</td> </tr> </table>	Power Supply Unit	POWER	Lit	Coordinator Module	RDY	Lit	RUN	Lit	ERR	---	PRPHL	OFF	COMM1	---	COMM2	---	Communications error	None	None	A communications error occurred between the peripheral port and the connected device.	Check the cables. Also, check the setting of DIP Switch pin 2 and the communications settings for the peripheral port in the System Setup and correct any mistakes.
Power Supply Unit	POWER	Lit																			
Coordinator Module	RDY	Lit																			
	RUN	Lit																			
	ERR	---																			
	PRPHL	OFF																			
	COMM1	---																			
	COMM2	---																			
<table border="1"> <tr> <td>Power Supply Unit</td> <td>POWER</td> <td>Lit</td> </tr> <tr> <td rowspan="6">Coordinator Module</td> <td>RDY</td> <td>Lit</td> </tr> <tr> <td>RUN</td> <td>Lit</td> </tr> <tr> <td>ERR</td> <td>---</td> </tr> <tr> <td>PRPHL</td> <td>---</td> </tr> <tr> <td>COMM1</td> <td>OFF</td> </tr> <tr> <td>COMM2</td> <td>OFF</td> </tr> </table>	Power Supply Unit	POWER	Lit	Coordinator Module	RDY	Lit	RUN	Lit	ERR	---	PRPHL	---	COMM1	OFF	COMM2	OFF	Communications error	None	None	A communications error occurred between the RS-232C port and the connected device.	Check the host link port settings in the System Setup. Check the cable wiring. If a host computer is connected, check the host computer's serial port settings and the program.
Power Supply Unit	POWER	Lit																			
Coordinator Module	RDY	Lit																			
	RUN	Lit																			
	ERR	---																			
	PRPHL	---																			
	COMM1	OFF																			
	COMM2	OFF																			
<table border="1"> <tr> <td>Power Supply Unit</td> <td>POWER</td> <td>Lit</td> </tr> <tr> <td rowspan="6">Coordinator Module</td> <td>RDY</td> <td>Lit</td> </tr> <tr> <td>RUN</td> <td>Lit</td> </tr> <tr> <td>ERR</td> <td>---</td> </tr> <tr> <td>PRPHL</td> <td>---</td> </tr> <tr> <td>COMM1</td> <td>---</td> </tr> <tr> <td>COMM2</td> <td>OFF</td> </tr> </table>	Power Supply Unit	POWER	Lit	Coordinator Module	RDY	Lit	RUN	Lit	ERR	---	PRPHL	---	COMM1	---	COMM2	OFF	Communications error	None	None	A communications error occurred between the RS-422A port and the connected device.	Check whether the servo driver settings in the System Setup are correct. Check the cable wiring. Check the operating status of the connected servo driver.
Power Supply Unit	POWER	Lit																			
Coordinator Module	RDY	Lit																			
	RUN	Lit																			
	ERR	---																			
	PRPHL	---																			
	COMM1	---																			
	COMM2	OFF																			

### 9-2-6 Power Supply Check

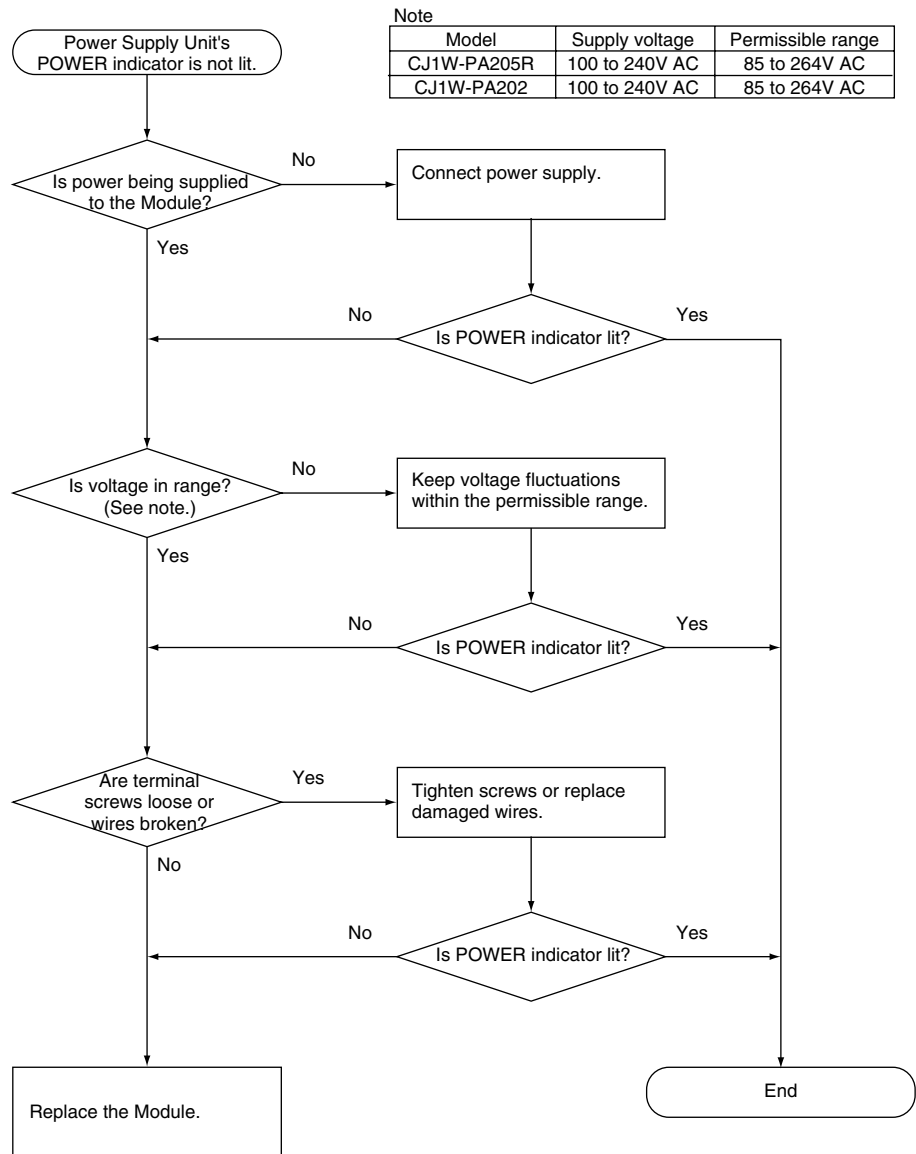

### 9-2-7 Memory Error Check

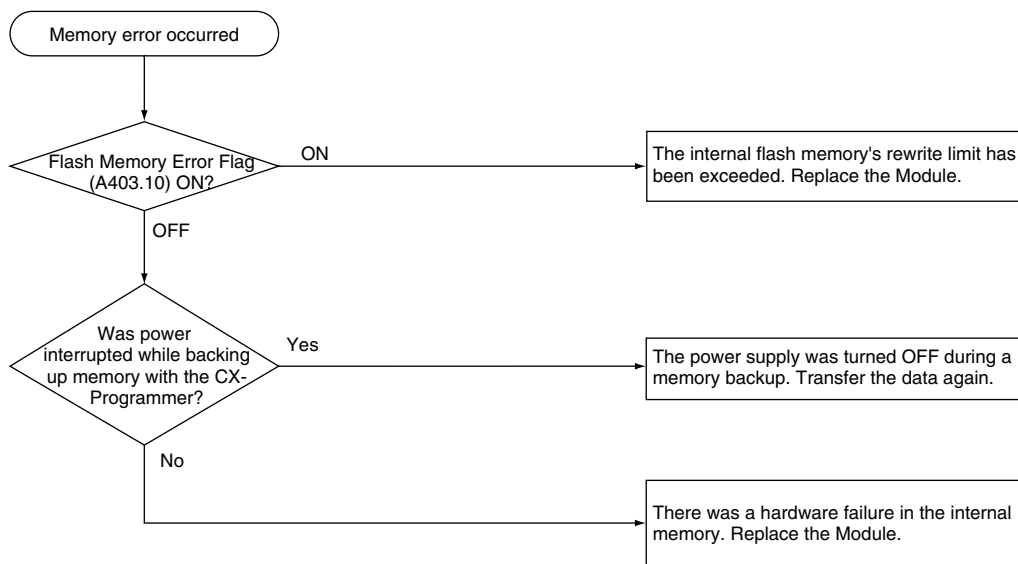

### 9-2-8 Program Error Check

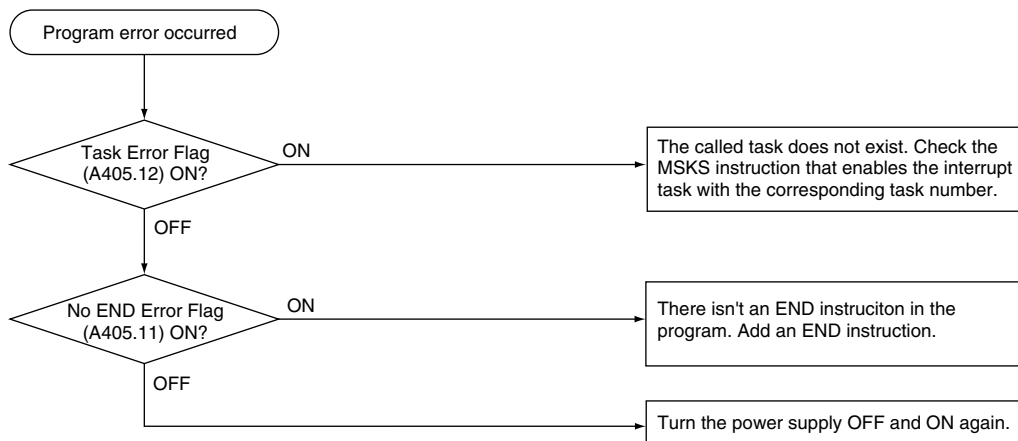

### 9-2-9 Cycle Time Overrun Error Check

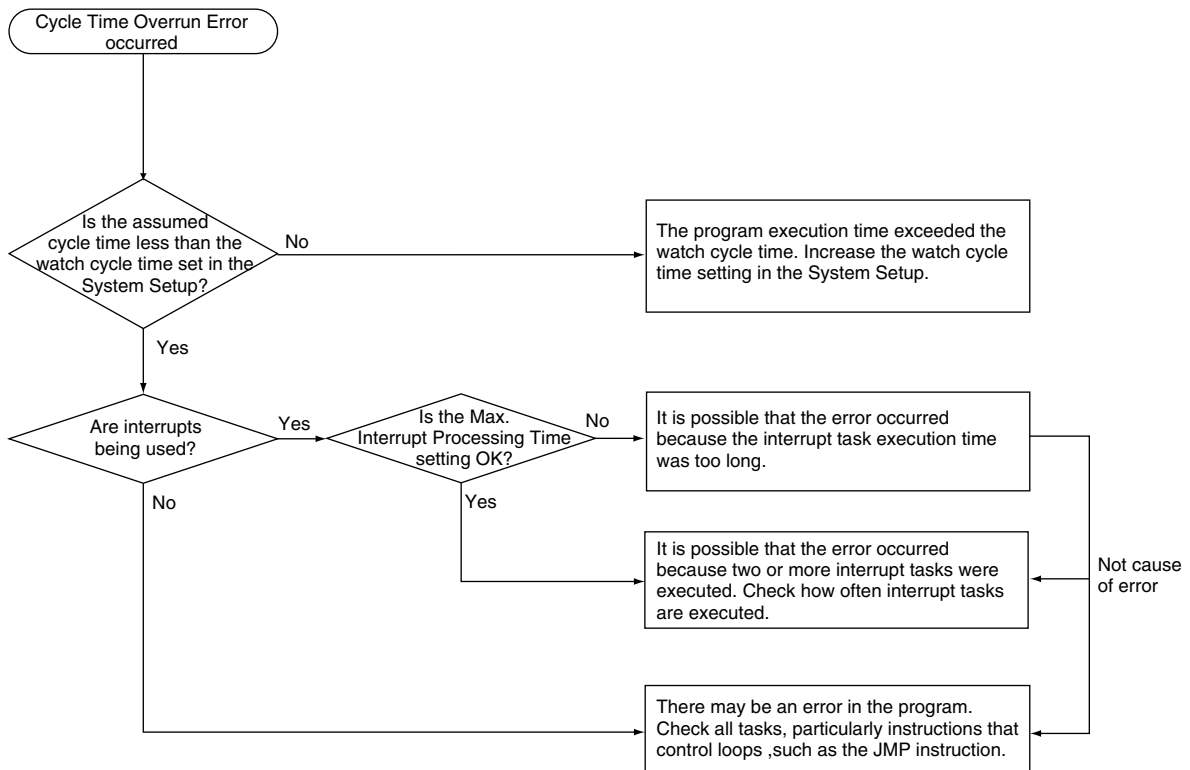

### 9-2-10 System Setup Error Check

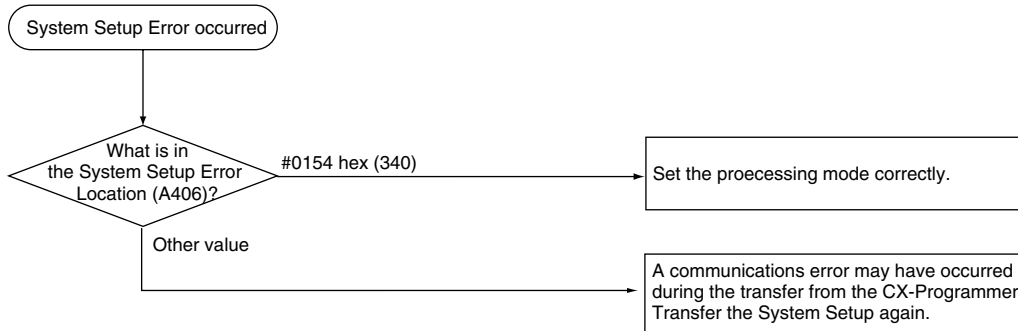

### 9-2-11 I/O Setting Error Check

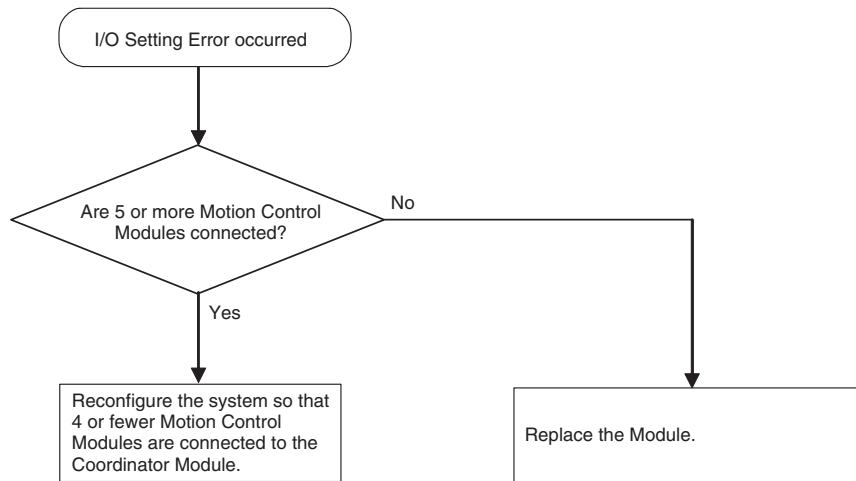

### 9-2-12 I/O Check

The I/O check flowchart is based on the following ladder diagram section, assuming that the problem is SOL1 does not turn ON.

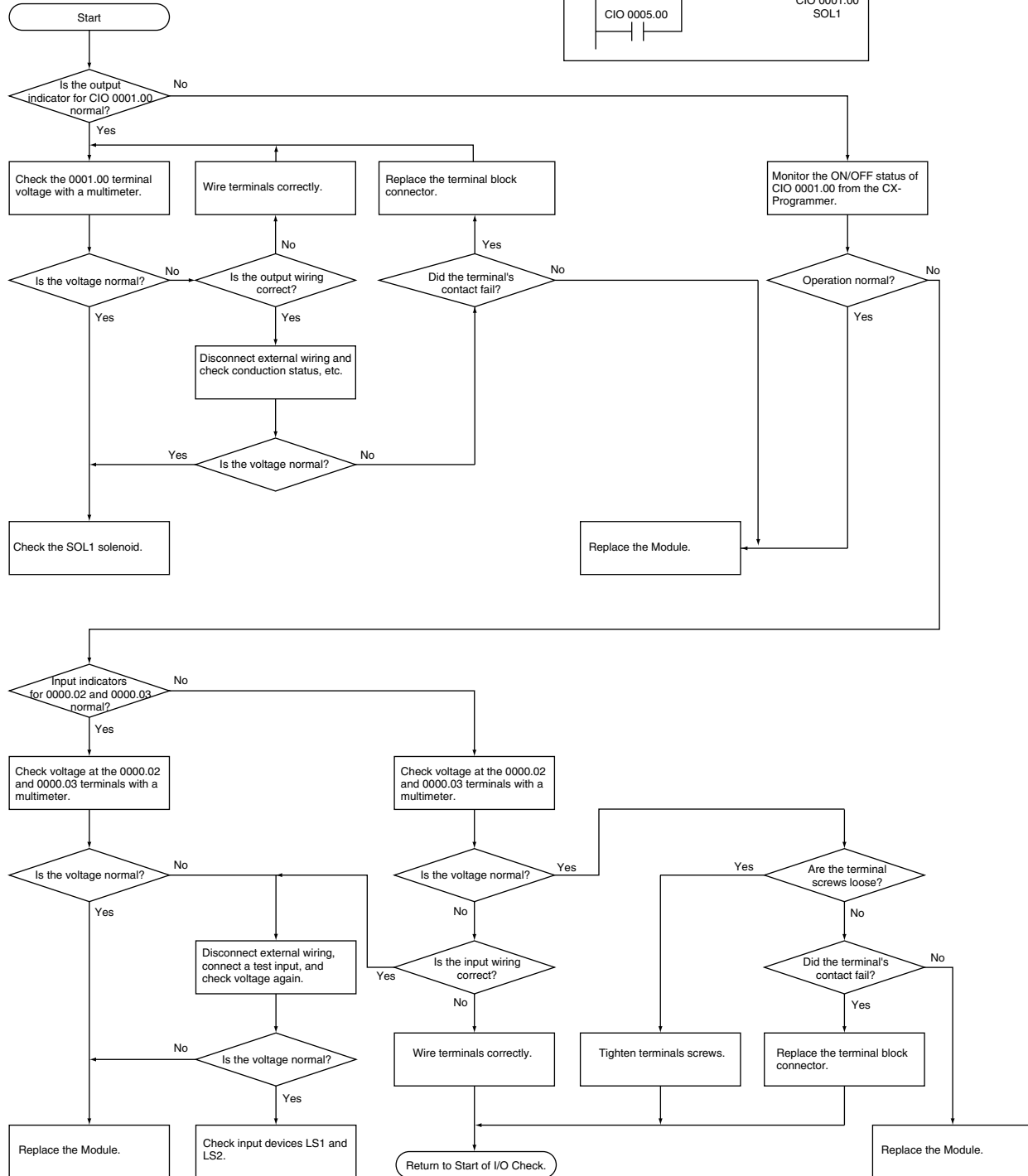
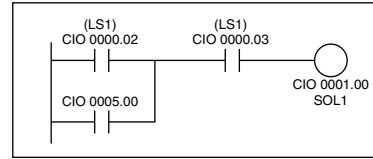

### 9-2-13 Environmental Conditions Check

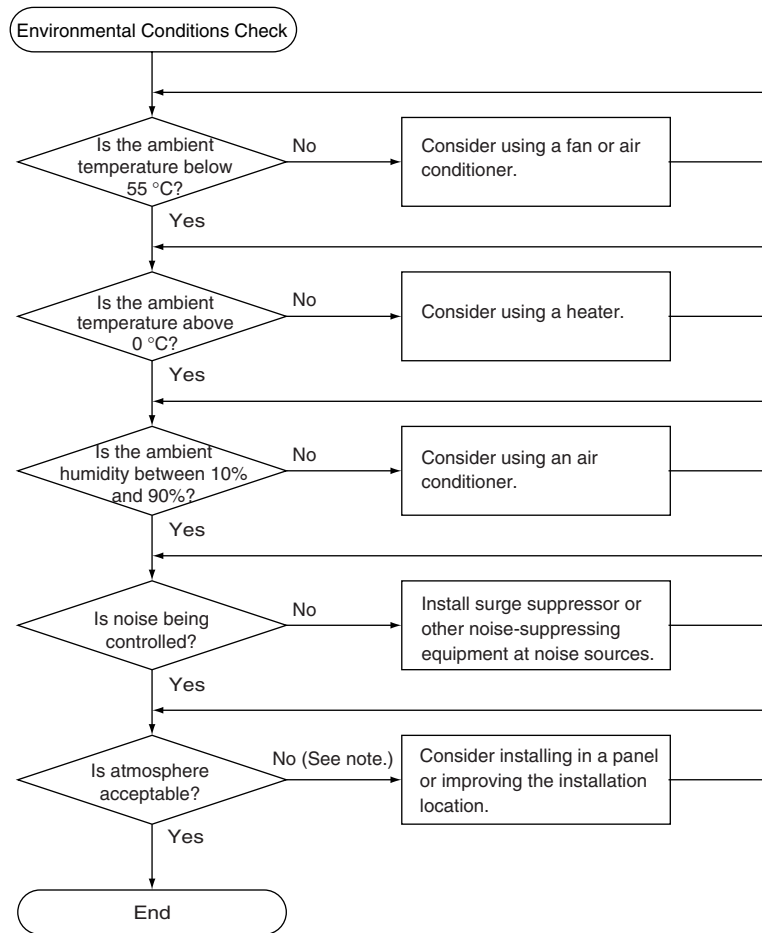

**Note** Prevent exposure to corrosive gases, flammable gases, dust, dirt, salts, metal dust, direct sunlight, water, oils, and chemicals.

## 9-3 Troubleshooting Problems in Modules

### Coordinator Module Errors

Error condition	Probable cause	Remedy
The Power Supply Unit's POWER indicator is not lit.	PCB short-circuited or damaged.	Replace the Power Supply Unit.
The RDY indicators on the Modules do not go ON.	The power supply line is faulty	Replace the Power Supply Unit.
The Coordinator Module's RUN indicator does not go ON.	An error in program is causing a fatal error	Correct program
The Power Supply Unit's RUN output* does not turn ON. The Coordinator Module's RUN indicator is lit. (*CJ1W-PA205R Power Supply Unit only)	Internal circuitry of Power Supply Unit is faulty.	Replace the Power Supply Unit.
Motion Control Module does not operate or does not operate properly.	The I/O bus is faulty.	Replace the Motion Control Module.
A particular I/O point does not operate.		
Error occurs in 8-point or 16-point units.		
A particular I/O point stays ON.		
None of a particular Module's I/O points will go ON.		



**Motion Control Module Errors**

Error condition	Probable cause	Remedy
The Motion Control Module's RUN indicator does not go ON.	An error in program is causing a fatal error	Correct program.
Motion Control Module does not operate or does not operate properly.	The I/O bus is faulty.	Replace the Motion Control Module.
A particular I/O point does not operate.		
Error occurs in 8-point or 16-point units.		
A particular I/O point stays ON.		
None of a particular Module's I/O points will go ON.		

**Input Errors**

Error condition	Probable cause	Remedy
None of inputs turn ON. (Indicators are not lit.)	(1) External input power supply is not being supplied.	Connect a proper external input power supply.
	(2) The external input power supply voltage is too low.	Adjust supply voltage to within proper range.
	(3) Terminal block connector is not making good contact.	Replace terminal block connector.
None of inputs turn ON. (Indicators are lit.)	Input circuit is faulty.	Replace the Module.
None of inputs turn OFF.	Input circuit is faulty.	Replace the Module.
A particular input does not turn ON.	(1) Input device is faulty.	Replace the input device.
	(2) Input wiring disconnected.	Check input wiring.
	(3) Faulty terminal block connector contact.	Replace terminal block connector.
	(4) External input's ON time is too short.	Adjust input device
	(5) Faulty input circuit	Replace the Module.
	(6) An input bit address is used in an output instruction.	Correct program.
A particular input does not turn OFF.	(1) Input circuit is faulty.	Replace the Module.
	(2) An input bit address is used in an output instruction.	Correct program.
Input turns ON/OFF irregularly.	(1) External input voltage is low or unstable.	Adjust external input voltage to within the proper range.
	(2) Malfunction due to noise.	Take protective measures against noise, such as: (1) Install surge suppressor. (2) Install isolating transformer. (3) Install shielded cables between the inputs and loads.
	(3) Faulty terminal block connector contact.	Replace terminal block connector.
Errors occur in 8-point or 16-point blocks, i.e., for the same common.	(1) Faulty terminal block connector contact.	Replace terminal block connector.
	(2) Faulty data bus	Replace the Module.
	(3) Faulty CPU	Replace the Module.
Input indicator does not light, but input operates normally.	Faulty indicator or indicator circuit.	Replace the Module.

**Output Errors**

Error condition	Probable cause	Remedy
None of the outputs will go ON.	(1) The load power is not being supplied.	Supply power.
	(2) Load power supply voltage is too low.	Adjust voltage to within the allowed range.
	(3) Faulty terminal block connector contact.	Replace terminal block connector.
	(4) Output circuit is faulty.	Replace the Module.
None of the outputs will go OFF.	Output circuit is faulty.	Replace the Module.
A specific bit address' output does not turn ON. (Indicator is not lit.)	(1) Output ON time too short because of a program error.	Correct program to increase the time that the output is ON.
	(2) The bit's status is controlled by multiple output instructions.	Correct program so that each output bit is controlled by only one instruction.
	(3) Faulty output circuit.	Replace the Module.
A specific bit address' output does not turn ON. (Indicator is lit.)	(1) Faulty output device.	Replace output device.
	(2) Break in output wiring.	Check output wiring.
	(3) Faulty terminal block connector.	Replace terminal block connector.
A specific bit address' output does not turn OFF. (Indicator is not lit.)	Output does not turn OFF due to leakage current or residual voltage.	Replace external load or add dummy resistor.
Output of a specific bit number does not turn OFF. (Indicator lit.)	(1) The bit's status is controlled by multiple output instructions.	Correct program.
	(2) Faulty output circuit.	Replace the Module.
Output turns ON/OFF irregularly.	(1) Low or unstable load voltage.	Adjust load voltage to within proper range
	(2) The bit's status is controlled by multiple output instructions.	Correct program so that each output bit is controlled by only one instruction.
	(3) Malfunction due to noise.	Take protective measures against noise, such as: (1) Install surge suppressor. (2) Install isolating transformer. (3) Install shielded cables between the outputs and loads.
	(4) Faulty terminal block connector contact.	Replace terminal block connector.
Errors occur in 8-point or 16-point blocks, i.e., for the same common.	(1) Faulty terminal block connector contact.	Replace terminal block connector.
	(2) Faulty data bus	Replace the Module.
	(3) Faulty CPU	Replace the Module.
Output indicator does not light, but output operates normally.	Faulty indicator or indicator circuit.	Replace the Module.

# SECTION 10

## Inspection and Maintenance

This section provides inspection and maintenance information.

10-1	Inspections .....	258
10-1-1	Inspection Points.....	258
10-1-2	Module Replacement Precautions .....	259

## 10-1 Inspections

Daily or periodic inspections are required in order to maintain the FQM1 in peak operating condition.

### 10-1-1 Inspection Points

Although the major components in the FQM1 have an extremely long life time, they can deteriorate under improper environmental conditions. Periodic inspections are thus required to ensure that the required condition is being maintained.

Inspection is recommended at least once every six months to a year, but more frequent inspections will be necessary in adverse environments.

Take immediate steps to correct the situation if any of the conditions in the following table are not met.

#### Inspection Points for Periodic Inspections

No.	Item	Inspection	Criteria	Action
1	Source Power Supply	Check for voltage fluctuations at the power supply terminals.	The voltage must be within the allowable voltage fluctuation range. (See note.)	Use a voltage tester to check the power supply at the terminals. Take necessary steps to bring voltage fluctuations within limits.
2	I/O Power Supply	Check for voltage fluctuations at the I/O terminals.	Voltages must be within specifications for each Module.	Use a voltage tester to check the power supply at the terminals. Take necessary steps to bring voltage fluctuations within limits.
3	Ambient environment	Check the ambient temperature. (Inside the control panel if the FQM1 is in a control panel.)	0 to 55°C	Use a thermometer to check the temperature and ensure that the ambient temperature remains within the allowed range of 0 to 55°C.
		Check the ambient humidity. (Inside the control panel if the FQM1 is in a control panel.)	Relative humidity must be 10% to 90% with no condensation.	Use a hygrometer to check the humidity and ensure that the ambient humidity remains within the allowed range.  In particular, verify that there is no condensation or icing caused by sudden temperature changes.
		Check that the FQM1 is not in direct sunlight.	Not in direct sunlight	Protect the FQM1 if necessary.
		Check for accumulation of dirt, dust, salt, metal filings, etc.	No accumulation	Clean and protect the FQM1 if necessary.
		Check for water, oil, or chemical sprays hitting the FQM1.	No spray on the FQM1	Clean and protect the FQM1 if necessary.
		Check for corrosive or flammable gases in the area of the FQM1.	No corrosive or flammable gases	Check by smell or use a sensor.
		Check the level of vibration or shock.	Vibration and shock must be within specifications.	Install cushioning or shock absorbing equipment if necessary.
Check for noise sources near the FQM1	No significant noise sources	Either separate the FQM1 and noise source or protect the FQM1.		

No.	Item	Inspection	Criteria	Action
4	Installation and wiring	Check that each Module is connected and locked to the next Module securely.	No looseness	Press the connectors together completely and lock them with the sliding latches.
		Check that cable connectors are fully inserted and locked.	No looseness	Correct any improperly installed connectors.
		Check for loose screws in external wiring.	No looseness	Tighten loose screws with a Phillips-head screwdriver.
		Check crimp connectors in external wiring.	Adequate spacing between connectors	Check visually and adjust if necessary.
		Check for damaged external wiring cables.	No damage	Check visually and replace cables if necessary.

**Note** The following table shows the allowable voltage fluctuation ranges for source power supplies.

Supply voltage	Allowable voltage range
100 to 240 V AC	85 to 264 V AC

### Tools Required for Inspections

**Required Tools**

- Phillips-head screwdriver
- Voltage tester or digital multimeter
- Industrial alcohol and clean cotton cloth

**Tools Required Occasionally**

- Synchroscope
- Oscilloscope with pen plotter
- Thermometer and hygrometer (humidity meter)

### 10-1-2 Module Replacement Precautions

Check the following after replacing any faulty Module.

- Do not replace a Module until the power is turned OFF.
- Check the new Module to make sure that there are no errors.
- If a faulty Module is being returned for repair, describe the problem in as much detail as possible, enclose this description with the Module, and return the Module to your OMRON representative.
- For poor contact, take a clean cotton cloth, soak the cloth in industrial alcohol, and carefully wipe the contacts clean. Be sure to remove any lint prior to remounting the Module.

- Note**
- (1) When replacing a Coordinator Module or Motion Control Module, be sure that not only the user program but also all other data required for operation is transferred to or set in the new Coordinator Module before starting operation, including DM Area and System Setup settings. If data area and other data are not correct for the user program, unexpected operation or accidents may occur.
  - (2) The System Setup is stored in the parameter area within the Coordinator Module or Motion Control Module. Be sure to transfer these settings to the new Coordinator Module or Motion Control Module when replacing a Module.
  - (3) After replacing a Motion Control Module, always set the required settings.
  - (4) In some cases, parameter data used in the Motion Control Modules is actually stored in the Coordinator Module's DM Area, so be sure to transfer the DM Area settings when replacing a Coordinator Module.



# Appendix A

## Programming

### Programs and Tasks

#### Tasks

There are basically two types of task.

1. Cyclic Task  
The cyclic task is executed once each cycle.
2. Interrupt Tasks  
An interrupt task is executed when the interrupt condition is met, even if this occurs while the cyclic task is being executed.  
There are three types of interrupt task.

Type of task	Description
Sync mode scheduled interrupt tasks	The sync mode scheduled interrupt task is executed once every sync cycle. This interrupt task is supported only by the Coordinator Module.
Input interrupt tasks	Input interrupt tasks are executed when a built-in input turns ON, OFF, or both on a Motion Control Module.
Normal interrupt tasks	Other interrupt tasks can be executed according to task number specified in programming instructions. These include one-shot interrupts, interval timer interrupts, high-speed counter target value interrupts, pulse output counter target value interrupts, etc.

The CX-Programmer can be used to allocate one program to each of many tasks, as required by the system.

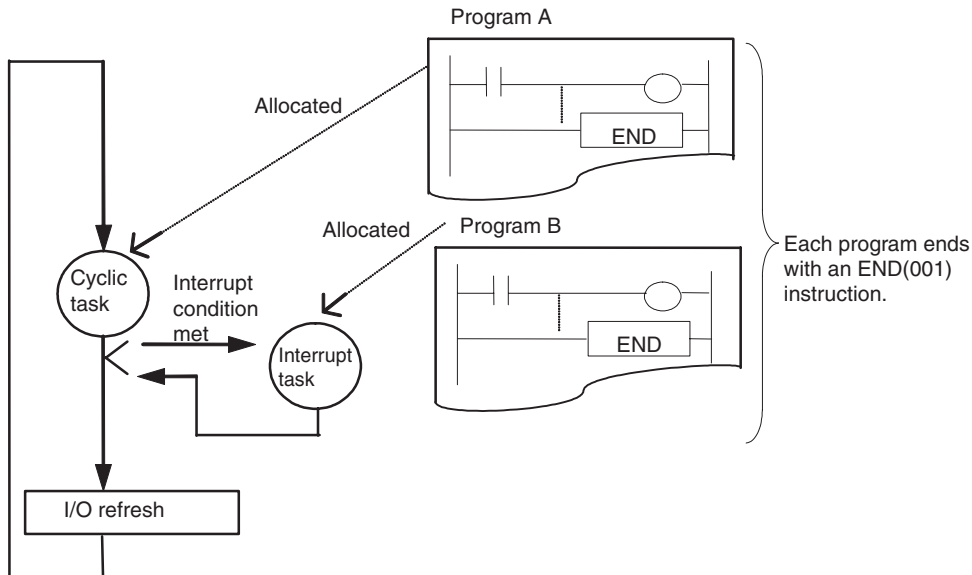

# Subroutines

## What Are Subroutines?

A subroutine is a program written between the SBN(092) and RET(093) instructions in a special subroutine area. A subroutine is called from the main program using the SBS(091), MCRO(099), or JSB(982) instruction. Subroutines can be used in the following three ways with the FQM1.

Type of subroutine	Description	Calling instruction
Normal subroutines	Normal subroutines are executed without passing parameters.	SBS(091)
Subroutines for which parameters are passed	<ul style="list-style-type: none"> <li>Parameters can be passed to the subroutine.</li> <li>The results of processing in the subroutine can be returned to the main program.</li> </ul>	MCRO(099)
	<ul style="list-style-type: none"> <li>Flags can be used to access the input condition to the subroutine while the subroutine is being executed.</li> <li>It's possible to check to see if a subroutine has been executed in the past.</li> <li>Parameters can be passed to and from the subroutine using storage registers.</li> </ul>	JSB(982)

## Using Normal Subroutines

A normal subroutine is written between the SBN(092) and RET(093) instructions and called using the SBS(091) instruction.

1. Write the program to be executed between SBN(092) and RET(093).
2. Set the subroutine number for the operand of SBN(092).
3. Call the subroutine using SBS(091)

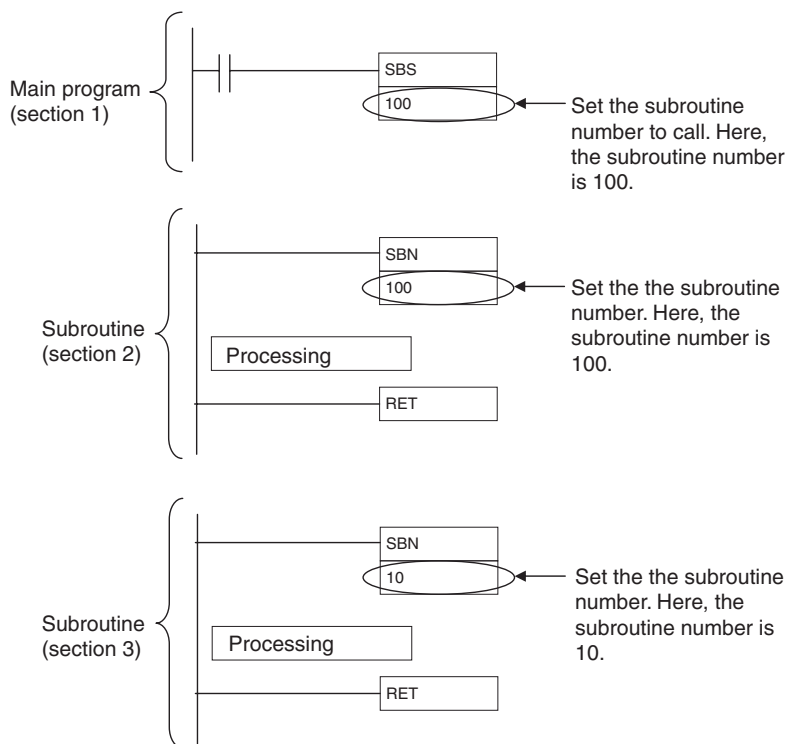



## Using Subroutines That Pass Parameters

With these subroutines, parameters can be passed to the subroutine when it is called and then the results of processing in the subroutine can be returned to the main program. This enables using one subroutine while changing the I/O addresses that are used. One subroutine can thus be used in multiple locations with similar logic in the program to reduce the number of program steps and make the program easier to understand.

When passing parameters to a subroutine, execution is possible either with or without using Subroutine Input Condition Flags.

### **Execution without Subroutine Input Condition Flags**

The MCRO(099) instruction is used to call subroutines without Subroutine Input Condition Flags.

MCRO(099)
Subroutine number
First input parameter word
First output parameter word

The following process is performed when MCRO(099) is executed.

1. Five words starting with the first input parameter word are copied to A510 through A514 (macro area inputs).
2. The specified subroutine is executed through RET(093).
3. When the subroutine is completed, the contents of A515 through A519 (macro area outputs) are copied to five words starting with the first output parameter word.
4. Program execution continues with the next instruction after MCRO(099).

The first input and output parameter words can be changed when executing MCRO(099) to use the same subroutine for different purposes at different locations in the program.

As shown by the above process, using the macro function has the following limitations.

- The parameters being passed must be stored in 5 continuous words.
- The specified I/O parameters must be passed so that they correctly correspond to the program in the subroutine.

- Note**
- (1) A510 through A514 (macro area inputs) and A515 through A519 (macro area outputs) can be used as work bits if MCRO(099) is not used.
  - (2) The words specified for the input/output parameter words can be I/O words, Auxiliary Area words, DM Area words, or words in other memory areas.
  - (3) The subroutines called by MCRO(099) must be written in the same way as a normal subroutine, e.g., between SBN(092) and RET(093).

### **Execution with Subroutine Input Condition Flags**

#### **Overview**

Subroutines called with JSB(982) are always executed regardless of the input condition to the instruction. The status of the input condition, however, is stored in an Auxiliary Area bit so that the status can be used to control program execution within the subroutine.

Subroutines called with JSB(982) are executed even if their input condition is OFF and even in program sections interlocked with IL(002). The status of the input condition is stored in the Subroutine Input Condition Flag corresponding to the subroutine. Subroutine Input Condition Flags are from A000 to A015 and correspond to the subroutine numbers. The Subroutine Input Condition Flag can be used within the subroutine to control program execution.

For example, a subroutine could perform jogging when the input condition is ON and perform stop processing or deceleration when the input condition is OFF, or a subroutine could execute a communications instruction when the input condition turned ON and then continue to monitor communications until a response is received after the input condition turns OFF.

- Note**
- (1) Index registers have been used to increase the usability of subroutines called with JSB(982). The actual addresses in I/O memory of the first input parameter word and first output parameter word are automatically stored in index registers IR0 and IR1, respectively. This enables accessing the input parameter words in the subroutine by indirectly addressing IR0 to read the input parameters for specific processing, as well as accessing the output parameter words in the subroutine by indirectly addressing IR1 to write data for output.
  - (2) When a subroutine is called with SBS(091), the entire subroutine will be skipped when the input condition is OFF, making it impossible to program processing for OFF input conditions (e.g., stopping processing or decelerating for an OFF input condition in a subroutine that performs jogging for an ON input condition).
  - (3) When a subroutine is called with SBS(091), it is not possible to tell from within the subroutine if the subroutine has been executed before. This makes it impossible to perform different processing in different cycles, such as spreading processing over multiple cycles.

**JSB(982) Operation**

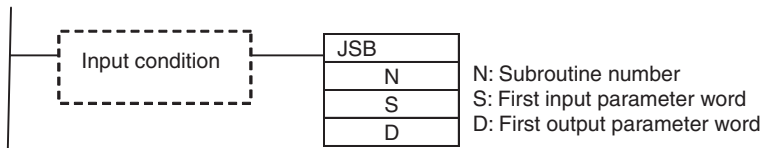

**Note** JSB(982) will be executed even if the input condition is OFF.

The following process is performed when JSB(982) is executed.

- 1. When the subroutine is called, the status of the input condition for JSB(982) is stored in the corresponding Subroutine Input Condition Flag.

Address		Corresponding subroutines
Word	Bits	
A000	00 to 15	SBN000 to SBN015
A001	00 to 15	SBN016 to SBN031
A002	00 to 15	SBN032 to SBN047
.	.	.
.	.	.
.	.	.
A015	00 to 15	SBN240 to SBN255

- 2. The actual addresses in I/O memory of the first input parameter word and first output parameter word are automatically stored in index registers IR0 and IR1, respectively
- 3. The specified subroutine is executed through RET(093).
- 4. Program execution continues with the next instruction after JSB(982).

**Note** If JSB(982) is within a program section interlocked by IL(002) and ILC(003), the subroutine will still be executed, but the interlock will apply to the program in the subroutine as well.

Application Examples

Execution without Subroutine Input Condition Flags

Without Macro Function



With Macro Function

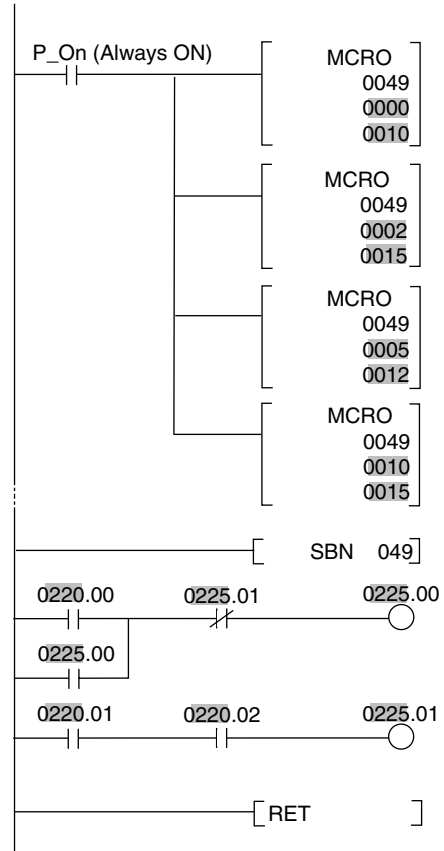
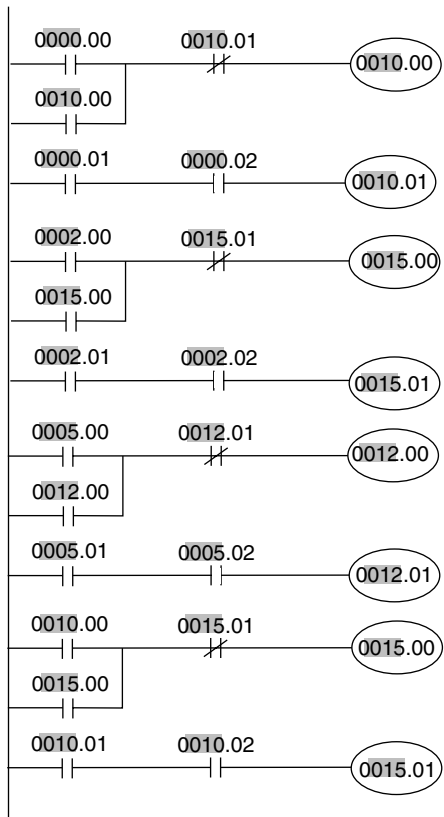

**Execution with Subroutine Input Condition Flags**

**Main Program**

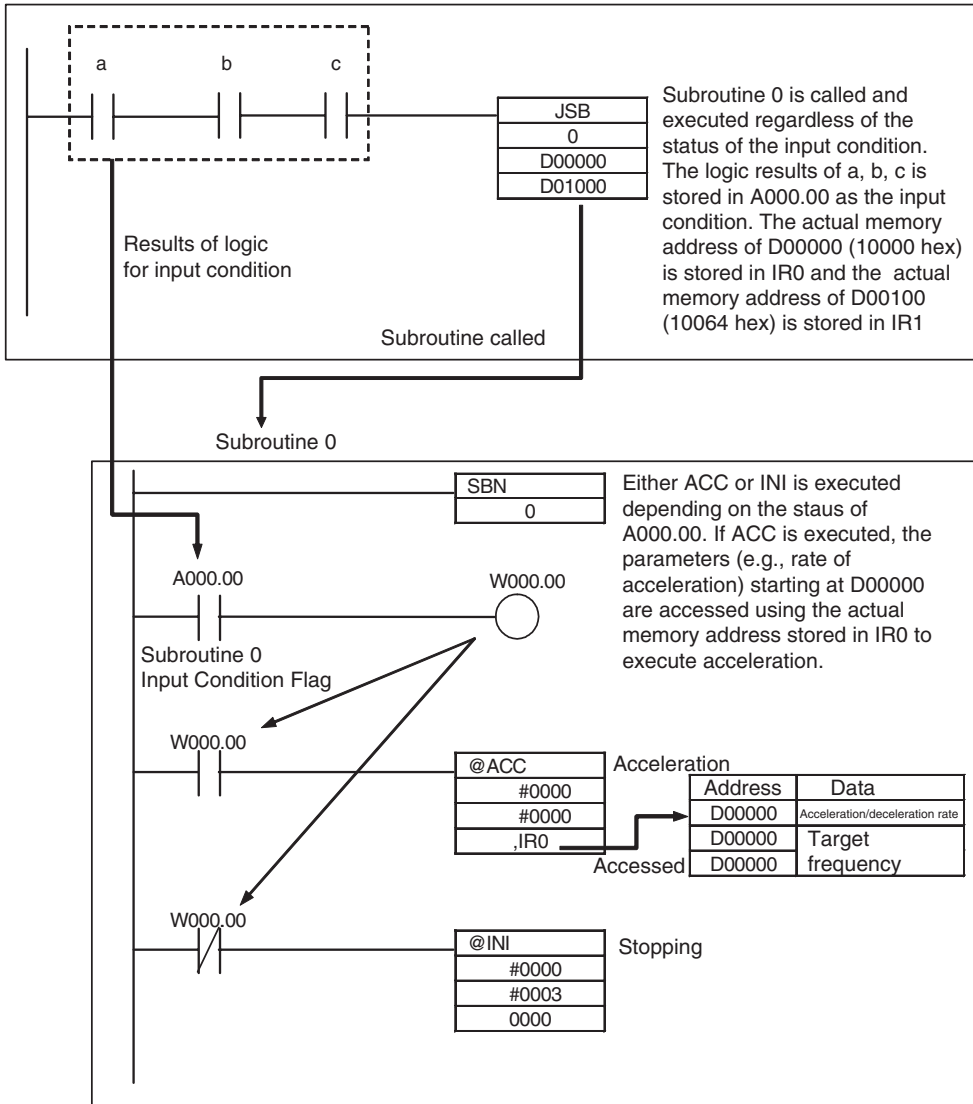

# Basic Information on Programming

## Basic Information on Instructions

Programs consist of instructions. The conceptual structure of the inputs to and outputs from an instruction is shown in the following diagram.

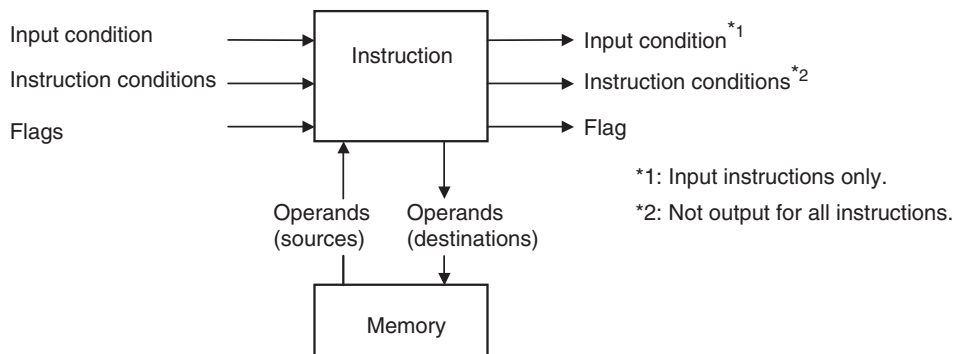

### Power Flow

The power flow is the input condition that is used to control the execution of instructions when programs are executing normally. In a ladder program, power flow represents the status of the input condition.

#### 1. Input Instructions

- Load instructions indicate a logical start and output the input condition.

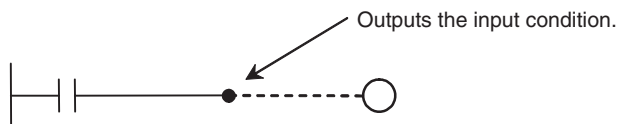

- Intermediate instructions input the power flow as an input condition and output the power flow to an intermediate or output instruction as an input condition.

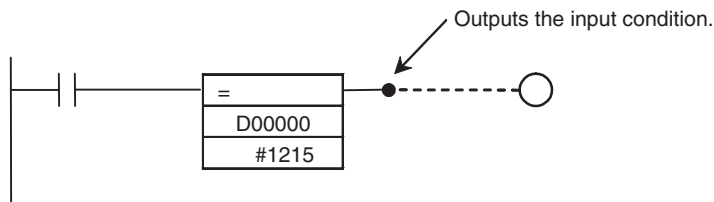

#### 2. Output Instructions

Output instructions execute functions, using the power flow as an input condition.

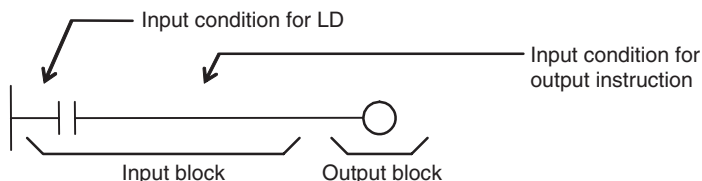

### Instruction Conditions

Instruction conditions are special conditions related to overall instruction execution that are output by the instructions listed below. Instruction conditions have a higher priority than the input condition when it comes to deciding whether or not to execute an instruction. An instruction may not be executed or may act differently depending on instruction conditions. Instruction conditions are reset (canceled) at the start of each task, i.e., they are reset when the task changes.

The following instructions are used in pairs to set and cancel certain instruction conditions. Each pair of instructions must be in the same task.

Instruction condition	Description	Setting instruction	Canceling instruction
Interlocked	An interlock turns OFF part of the program. Special conditions, such as turning OFF output bits, resetting timers, and holding counters, are in effect.	IL(002)	ILC(003)
Block program execution	A program block from BPRG(096) to BEND(801) is executed.	BPRG(096)	BEND(801)

### Flags

In this context, a flag is a bit that serves as an interface between instructions.

Input flags	Output flags
<ul style="list-style-type: none"> <li>• Differentiation Flags Differentiation result flags. The status of these flags are input automatically to the instruction for all differentiated up/down output instructions and the DIFU(013)/DIFD(014) instructions.</li> <li>• Carry (CY) Flag The Carry Flag is used as an unspecified operand in data shift instructions and addition/subtraction instructions.</li> </ul>	<ul style="list-style-type: none"> <li>• Condition Flags Condition Flags include the Always ON/OFF Flags, as well as flags that are updated by results of instruction execution. In user programs, these flags can be specified by labels, such as ER, CY, &gt;, =, A1, A0, rather than by addresses.</li> </ul>

### Operands

Operands specify preset instruction parameters (boxes in ladder diagrams) that are used to specify I/O memory area contents or constants. An instruction can be executed by entering an address or constant as the operands. Operands are classified as source, destination, or number operands.

Example

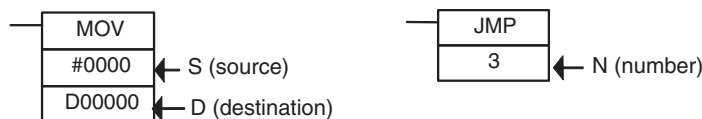

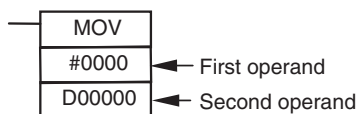

Operand types		Operand symbol	Description	
Source	Specifies the address of the data to be read or a constant.	S	Source operand	Source operand other than control data (C)
		C	Control data	Compound data in a source operand that has different meanings depending bit status.
Destination (Results)	Specifies the address where data will be written.	D	---	---
Number	Specifies a particular number used in the instruction, such as a jump number or subroutine number.	N	---	---

**Note** Operands are also called the first operand, second operand, and so on, starting from the top of the instruction.



## Instruction Location and Input Conditions

The following table shows the possible locations for instructions. Instructions are grouped into those that do and those do not require input conditions.

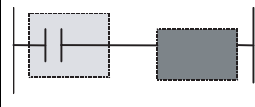
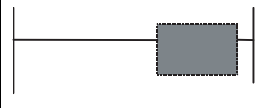
Instruction type		Possible location	Input condition	Diagram	Examples
Input instructions	Logical start (Load instructions)	Connected directly to the left bus bar or is at the beginning of an instruction block.	Not required.		LD, LD >, and other symbol comparison instructions
	Intermediate instructions	Between a logical start and the output instruction.	Required.		AND, OR, AND >, and other symbol comparison instructions)
Output instructions		Connected directly to the right bus bar.	Required.		Most instructions including OUT and MOV(021).
			Not required.		END(001), JME(005), ILC(003), etc.

- Note**
- (1) There is another group of instructions that executes a series of mnemonic instructions based on a single input. These are called block programming instructions. Refer to the *Instructions Reference Manual* (Cat. No. O011) for details on these block programs.
  - (2) If an instruction requiring an input condition is connected directly to the left bus bar without a logical start instruction, a program error will occur when checking the program on the CX-Programmer.

## Addressing I/O Memory Areas

### Bit Addresses

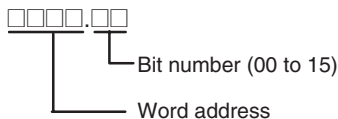

**Example:** The address of bit 03 in word 0001 in the CIO Area would be as shown below. This address is given as “CIO 0001.03” in this manual.

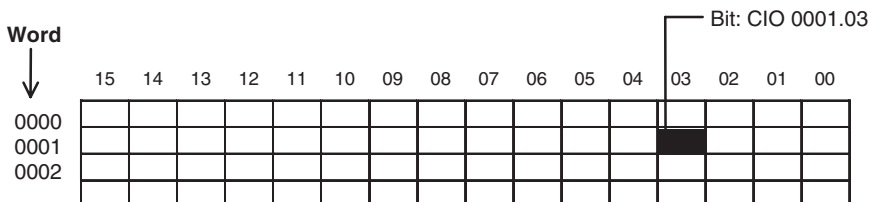
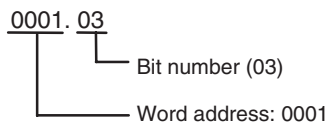

### Word Addresses



**Example:** The address of bits 00 to 15 in word 0010 in the CIO Area would be as shown below. This address is given as “CIO 0010” in this manual.



DM Area addresses are given with “D” prefixes, as shown below for the address D00200.

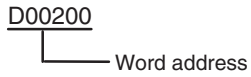

### Specifying Operands

Operand	Description	Notation	Application examples
Specifying bit addresses	<p>The word address and bit number are specified directly to specify a bit (input input bits).</p> <p>□□□□. □□</p> <p>└── Bit number (00 to 15)</p> <p>└── Word address</p> <p><b>Note</b> The same addresses are used to access timer/counter Completion Flags and Present Values.</p>	<p>0001 02</p> <p>└── Bit number (02)</p> <p>└── Word address: 0001</p>	<p>0001.02</p> <p>— —</p>
Specifying word addresses	<p>The word address is specified directly to specify the 16-bit word.</p> <p>□□□□</p> <p>└── Word address</p>	<p>0003</p> <p>└── Word address: 0003</p> <p>D00200</p> <p>└── Word address: 00200</p>	<p>MOV 0003</p> <p>D00200</p>



Operand	Description	Notation	Application examples
Specifying indirect DM addresses in Binary Mode	<p>The offset from the beginning of the area is specified. The contents of the address will be treated as binary data (00000 to 32767) to specify the word address in Data Memory (DM). Add the @ symbol at the front to specify an indirect address in binary mode.</p> <p style="text-align: center;">@D□□□□□</p> <p style="text-align: center;">↓</p> <p>Contents <span style="border: 1px solid black; display: inline-block; width: 60px; height: 15px;"></span> 00000 to 32767 (0000 Hex to 7FFF Hex)</p> <p style="text-align: center;">↓</p> <p>D <span style="border: 1px solid black; display: inline-block; width: 60px; height: 15px;"></span></p>		
	1) D00000 to D32767 are specified if @D(□□□□□) contains 0000 hex to 7FFF hex (00000 to 32767).	<p>@D00300</p> <p style="text-align: center;"> <span style="border: 1px solid black; display: inline-block; width: 40px; height: 15px; text-align: center;">0 1 0 0</span> Contents                      Binary: 256                      ↓                      Specifies D00256.                 </p> <p>— Add the @ symbol.</p>	MOV #0001 @D00300
	<p>The offset from the beginning of the area is specified. The contents of the address will be treated as BCD data (0000 to 9999) to specify the word address in Data Memory (DM). Add an asterisk (*) at the front to specify an indirect address in BCD Mode.</p> <p style="text-align: center;">*D□□□□□</p> <p style="text-align: center;">↓</p> <p>Contents <span style="border: 1px solid black; display: inline-block; width: 60px; height: 15px; text-align: center;">: : : :</span> 00000 to 9999 (BCD)</p> <p style="text-align: center;">↓</p> <p>D <span style="border: 1px solid black; display: inline-block; width: 60px; height: 15px; text-align: center;">: : : :</span></p>	<p>*D00200</p> <p style="text-align: center;"> <span style="border: 1px solid black; display: inline-block; width: 40px; height: 15px; text-align: center;">0 1 0 0</span> Contents                      ↓                      Specifies D0100                 </p> <p>— Add an asterisk (*).</p>	MOV #0001 *D00200

**Note** With indirect address specifications in binary mode, the DM Area addresses are treated as consecutive memory addresses.

Operand	Description		Notation	Application examples
Specifying an indirect address using a register	Indirect address (No offset)	The bit or word with the memory address contained in IR□ will be specified.  Specify ,IR□ to specify bits and words for instruction operands.	,IR0  ,IR1	LD ,IR0 Loads the bit with the memory address in IR0.  MOV #0001 ,IR1 Stores #0001 in the word with the memory address in IR1.
	Constant offset	The bit or word with the memory address in IR□ + or – the constant is specified.  Specify +/- constant ,IR□. Constant offsets range from –2048 to +2047 (decimal). The offset is converted to binary data when the instruction is executed.	+5,IR0  +31,IR1	LD +5 ,IR0 Loads the bit with the memory address in IR0 + 5.  MOV #0001 +31 ,IR1 Stores #0001 in the word with the memory address in IR1 + 31
	Auto Increment	The contents of IR□ is incremented by +1 or +2 after referencing the value as an memory address.  +1: Specify ,IR□+ +2: Specify ,IR□ ++	,IR0 ++  ,IR1 +	LD ,IR0 ++ Increments the contents of IR0 by 2 after the bit with the memory address in IR0 is loaded.  MOV #0001 ,IR1 + Increments the contents of IR1 by 1 after #0001 is stored in the word with the memory address in IR1.
	Auto Decrement	The contents of IR□ is decremented by –1 or –2 after referencing the value as an memory address.  –1: Specify ,–IR□ –2: Specify ,– –IR□	,– –IR0  ,–IR1	LD ,– –IR0 After decrementing the contents of IR0 by 2, the bit with the memory address in IR0 is loaded.  MOV #0001 ,–IR1 After decrementing the contents of IR1 by 1, #0001 is stored in the word with the memory address in IR1.

Data	Operand	Data form	Symbol	Range	Application example
16-bit constant	All binary data or a limited range of binary data	Unsigned binary	#	#0000 to #FFFF	---
		Signed decimal	±	–32768 to +32767	---
		Unsigned decimal	&	&0 to &65535	---
	All BCD data or a limited range of BCD data	BCD	#	#0000 to #9999	---
32-bit constant	All binary data or a limited range of binary data	Unsigned binary	#	#00000000 to #FFFFFFFF	---
		Signed decimal	±	–2147483648 to +2147483647	---
		Unsigned decimal	&	&0 to &4294967295	---
	All BCD data or a limited range of BCD data	BCD	#	#00000000 to #99999999	---

Data	Operand	Data form	Symbol	Range	Application example																								
Text string		Text string data is stored in ASCII (one byte except for special characters) in order from the leftmost to the rightmost byte and from the rightmost (lower) to the leftmost word.  00 hex (NUL code) is stored in the rightmost byte of the last word if there is an odd number of characters.  0000 hex (2 NUL codes) is stored in the leftmost and rightmost vacant bytes of the last word + 1 if there is an even number of characters.	---		'ABCDE'  <table border="1"> <tr><td>'A'</td><td>'B'</td></tr> <tr><td>'C'</td><td>'D'</td></tr> <tr><td>'E'</td><td>NUL</td></tr> </table>     <table border="1"> <tr><td>41</td><td>42</td></tr> <tr><td>43</td><td>44</td></tr> <tr><td>45</td><td>00</td></tr> </table> 'ABCD'  <table border="1"> <tr><td>'A'</td><td>'B'</td></tr> <tr><td>'C'</td><td>'D'</td></tr> <tr><td>NUL</td><td>NUL</td></tr> </table>     <table border="1"> <tr><td>41</td><td>42</td></tr> <tr><td>43</td><td>44</td></tr> <tr><td>00</td><td>00</td></tr> </table>	'A'	'B'	'C'	'D'	'E'	NUL	41	42	43	44	45	00	'A'	'B'	'C'	'D'	NUL	NUL	41	42	43	44	00	00
'A'	'B'																												
'C'	'D'																												
'E'	NUL																												
41	42																												
43	44																												
45	00																												
'A'	'B'																												
'C'	'D'																												
NUL	NUL																												
41	42																												
43	44																												
00	00																												

ASCII characters that can be used in a text string includes alphanumeric characters, Katakana and symbols (except for special characters). The characters are shown in the following table.

		Upper 4 bits															
		0	1	2	3	4	5	6	7	8	9	A	B	C	D	E	F
Lower 4 bits	0			Sp	0	@	P	'	p					一	タ	ミ	
	1			!	1	A	Q	a	q					。	ア	チ	ム
	2			”	2	B	R	b	r					「	イ	ツ	メ
	3			#	3	C	S	c	s					」	ウ	テ	モ
	4			\$	4	D	T	d	t					、	エ	ト	ヤ
	5			%	5	E	U	e	u					・	オ	ナ	ユ
	6			&	6	F	V	f	v					ヲ	カ	ニ	ヨ
	7			'	7	G	W	g	w					ア	キ	ヌ	ラ
	8			(	8	H	X	h	x					イ	ク	ネ	リ
	9			)	9	I	Y	i	y					ウ	ケ	ノ	ル
	A			*	:	J	Z	j	z					エ	コ	ハ	レ
	B			+	;	K	[	k	{					オ	サ	ヒ	ロ
	C			,	<	L	¥							ヤ	シ	フ	ワ
	D			-	=	M	]	m	}					ユ	ス	ヘ	ン
	E			.	>	N	^	n	~					ヨ	セ	ホ	”
	F			/	?	O	_	o						ツ	ソ	マ	°

## Data Formats

The following table shows the data formats that the FQM1 can handle.

Data type	Data format	Decimal	4-digit hexadecimal
Unsigned binary	<p>Binary</p> <p>Decimal</p> <p>Hex</p>	0 to 65535	0000 to FFFF
Signed binary	<p>Binary</p> <p>Decimal</p> <p>Hex</p> <p>Sign bit: 0: Positive, 1: Negative</p>	0 to -32768 0 to +32767	8000 to 7FFF
BCD (binary coded decimal)	<p>Binary</p> <p>Decimal</p>	0 to 9999	0000 to 9999
Single-precision floating-point decimal	<p>Sign of mantissa</p> <p>Exponent</p> <p>Mantissa</p> <p>Binary</p> <p>Value = <math>(-1)^{\text{Sign}} \times 1.[\text{Mantissa}] \times 2^{\text{Exponent}}</math>              Sign (bit 31) 1: negative or 0: positive              Mantissa The 23 bits from bit 00 to bit 22 contain the mantissa, i.e., the portion below the decimal point in 1.□□□....., in binary.              Exponent The 8 bits from bit 23 to bit 30 contain the exponent. The exponent is expressed in binary as 127 plus n in <math>2^n</math>.</p> <p><b>Note</b> This format conforms to IEEE754 standards for single-precision floating-point data and is used only with instructions that convert or calculate floating-point data. It can be used to set or monitor from the I/O memory Edit and Monitor Screen on the CX-Programmer. As such, users do not need to know this format although they do need to know that the formatting takes up two words.</p>	---	---

### Note Signed Binary Data

In signed binary data, the leftmost bit indicates the sign of binary 16-bit data. The value is expressed in 4-digit hexadecimal.

**Positive Numbers:** A value is positive or 0 if the leftmost bit is 0 (OFF). In 4-digit hexadecimal, this is expressed as 0000 to 7FFF hex.

**Negative Numbers:** A value is negative if the leftmost bit is 1 (ON). In 4-digit hexadecimal, this is expressed as 8000 to FFFF hex. The absolute of the negative value (decimal) is expressed as a two's complement.

**Example:** To treat -19 in decimal as signed binary, 0013 hex (the absolute value of 19) is subtracted from FFFF hex and then 0001 hex is added to yield FFED hex.

	F	F	F	F
	1111	1111	1111	1111
True number	0	0	1	3
-)	0000	0000	0001	0011
	F	F	E	C
	1111	1111	1110	1100
+)	0	0	0	1
	0000	0000	0000	0001
Two's complement	F	F	E	D
	1111	1111	1110	1101

**Complements**

Generally the complement of base x refers to a number produced when all digits of a given number are subtracted from x - 1 and then 1 is added to the rightmost digit. (Example: The ten's complement of 7556 is 9999 - 7556 + 1 = 2444.) A complement is used to express a subtraction and other functions as an addition.

**Example:** With 8954 - 7556 = 1398, 8954 + (the ten's complement of 7556) = 8954 + 2444 = 11398. If we ignore the leftmost bit, we get a subtraction result of 1398.

**Two's Complements**

A two's complement is the base-two complement. Here, we subtract all digits from 1 (2 - 1 = 1) and add one.

**Example:** The two's complement of binary number 1101 is 1111 (F hex) - 1101 (D hex) + 1 (1 hex) = 0011 (3 hex). The following shows this value expressed in 4-digit hexadecimal.

The two's complement b hex of a hex is FFFF hex - a hex + 0001 hex = b hex. To determine the two's complement b hex of "a hex," use b hex = 10000 hex - a hex.

**Example:** To determine the two's complement of 3039 hex, use 10000 hex - 3039 hex = CFC7 hex.

Similarly use a hex = 10000 hex - b hex to determine the value a hex from the two's complement b hex.

**Example:** To determine the real value from the two's complement CFC7 hex, use 10000 hex - CFC7 hex = 3039 hex.

Two instructions, NEG(160)(2'S COMPLEMENT) and NEGL(161) (DOUBLE 2'S COMPLEMENT), can be used to determine the two's complement from the true number or to determine the true number from the two's complement.

**Note Signed BCD Data**

Signed BCD data is a special data format that is used to express negative numbers in BCD. Although this format is found in applications, it is not strictly defined and depends on the specific application. The FQM1 supports four data formats and supports the following instructions to convert the data formats: SIGNED BCD-TO-BINARY: BINS(470) and SIGNED BINARY-TO-BCD: BCDS(471). Refer to the *Instructions Reference Manual* (Cat. No. O011) for more information.

Decimal	Hexadecimal	Binary	BCD	
0	0	0000	0000	
1	1	0001	0001	
2	2	0010	0010	
3	3	0011	0011	
4	4	0100	0100	
5	5	0101	0101	
6	6	0110	0110	
7	7	0111	0111	
8	8	1000	1000	
9	9	1001	1001	
10	A	1010	0001	0000
11	B	1011	0001	0001
12	C	1100	0001	0010
13	D	1101	0001	0011
14	E	1110	0001	0100
15	F	1111	0001	0101
16	10	10000	0001	0110

Decimal	Unsigned binary (4-digit hexadecimal)	Signed binary (4-digit hexadecimal)
+65,535	FFFF	Cannot be expressed.
+65,534	FFFE	
.	.	
.	.	
+32,769	8001	7FFF
+32,768	8000	
+32,767	7FFF	
+32,766	7FFE	
.	.	7FFF
.	.	
.	.	
.	.	
+2	0002	0002
+1	0001	0001
0	0000	0000
-1	Cannot be expressed.	FFFF
-2		FFFE
.		.
.		.
-32,767		8001
-32,768		8000

## Instruction Variations

The following variations are available for instructions to differentiate executing conditions.

Variation	Symbol	Description
Differentiation	ON	@
	OFF	%

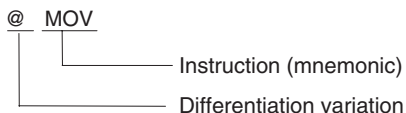

## Input Conditions

The FQM1 offers the following types of basic and special instructions.

- Non-differentiated instructions executed every cycle
- Differentiated instructions executed only once

### Non-differentiated Instructions

- Output instructions that require input conditions are executed once every cycle while the input condition is valid (ON or OFF).

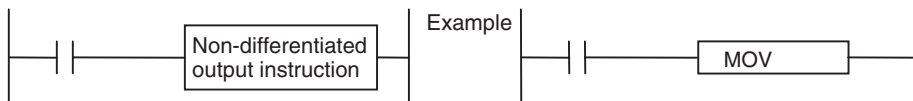

- Input instructions that create logical starts and intermediate instructions that read bit status, make comparisons, test bits, or perform other types of processing every cycle. If the results are ON, power flow is output (i.e., the input condition is turned ON).

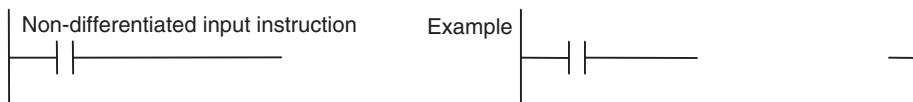

### Input-differentiated Instructions

- **Upwardly Differentiated Instructions (Instructions Preceded by @)**

- **Output Instructions:** The instruction is executed only during the cycle in which the input condition turns ON (OFF → ON) and are not executed in the following cycles.

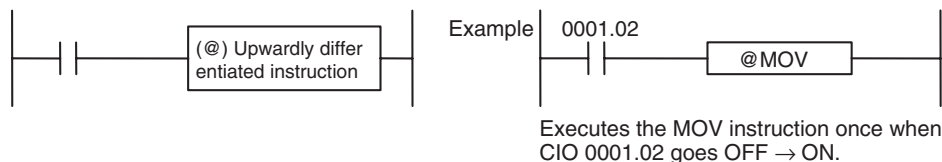

- **Input Instructions (Logical Starts and Intermediate Instructions):** The instruction reads bit status, makes comparisons, tests bits, or perform other types of processing every cycle and will output an ON execution condition (power flow) when results switch from OFF to ON. The execution condition will turn OFF the next cycle.

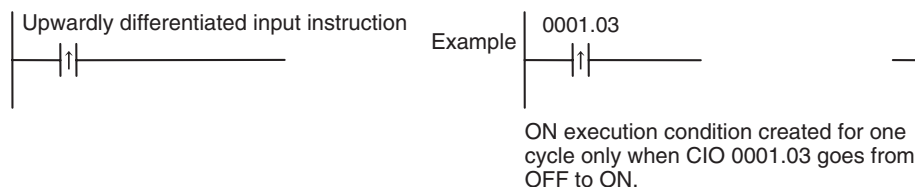

- **Input Instructions (Logical Starts and Intermediate Instructions):** The instruction reads bit status, makes comparisons, tests bits, or perform other types of processing every cycle and will output an OFF execution condition (power flow stops) when results switch from OFF to ON. The execution condition will turn ON the next cycle.

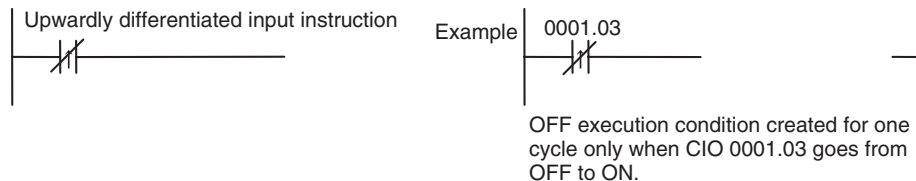

- **Downwardly Differentiated Instructions (Instruction preceded by %)**

- **Output instructions:** The instruction is executed only during the cycle in which the input condition turned OFF (ON → OFF) and is not executed in the following cycles.

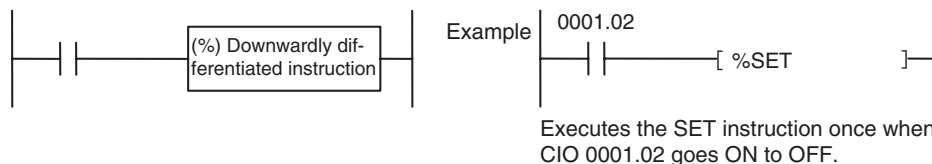

- **Input Instructions (Logical Starts and Intermediate Instructions):** The instruction reads bit status, makes comparisons, tests bits, or perform other types of processing every cycle and will output the execution condition (power flow) when results switch from ON to OFF. The execution condition will turn OFF the next cycle.

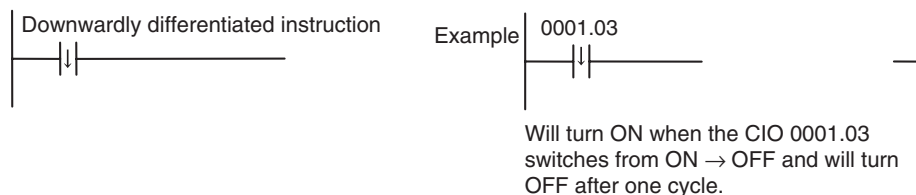

**Note** Unlike the upwardly differentiated instructions, downward differentiation variation (%) can be added only to LD, AND, OR, SET and RSET instructions. To execute downward differentiation with other instructions, combine the instructions with a DIFD instruction.

- **Input Instructions (Logical Starts and Intermediate Instructions):** The instruction reads bit status, makes comparisons, tests bits, or perform other types of processing every cycle and will output an OFF execution condition (power flow stops) when results switch from ON to OFF. The execution condition will turn ON the next cycle.

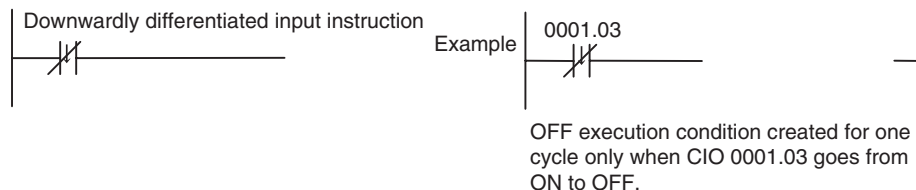



# Programming Precautions

## Condition Flags

### Using Condition Flags

Condition flags are shared by all instructions, and will change during a cycle depending on results of executing individual instructions. Therefore, be sure to use Condition Flags on a branched output with the same input condition immediately after an instruction to reflect the results of instruction execution. Never connect a Condition Flag directly to the bus bar because this will cause it to reflect execution results for other instructions.

**Example:** Using Instruction A Execution Results

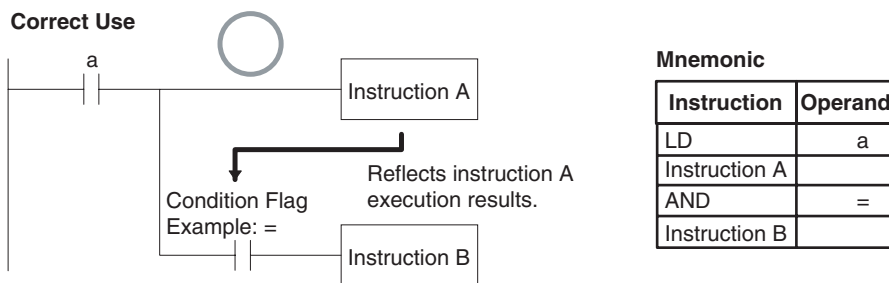

The same input condition (a) is used for instructions A and B to execute instruction B based on the execution results of instruction A. In this case, instruction B will be executed according to the Condition Flag only when instruction A is executed.

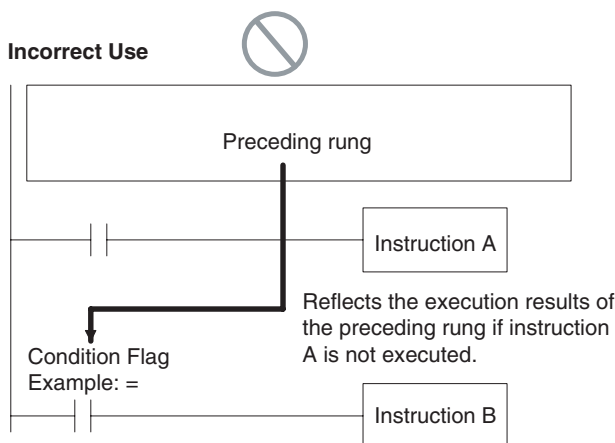

If the Condition Flag is connected directly to the left bus bar, instruction B will be executed based on the execution results of a previous rung if instruction A is not executed.

**Note** Condition Flags are used by all instruction within a single program (task) but they are cleared when the task switches. Therefore execution results in the preceding task will not be reflected later tasks.

Since condition flags are shared by all instructions, make absolutely sure that they do not interfere with each other within a single ladder-diagram program. The following are examples.

**1. Using Execution Results in NC and NO Inputs**

The Condition Flags will pick up instruction B execution results as shown in the example below even though the NC and NO input bits are executed from the same output branch.

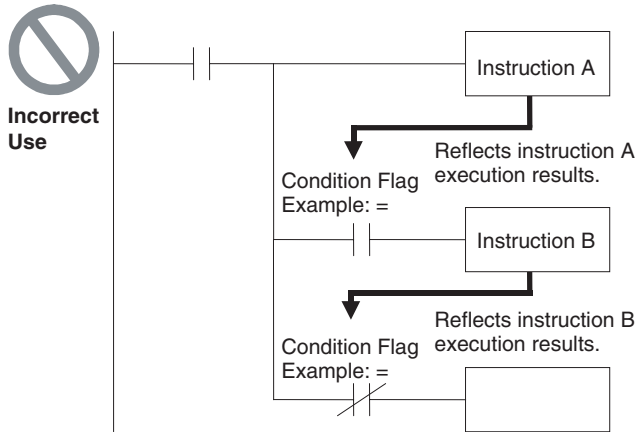

Make sure each of the results is picked up once by an OUTPUT instruction to ensure that execution results for instruction B will be not be picked up.

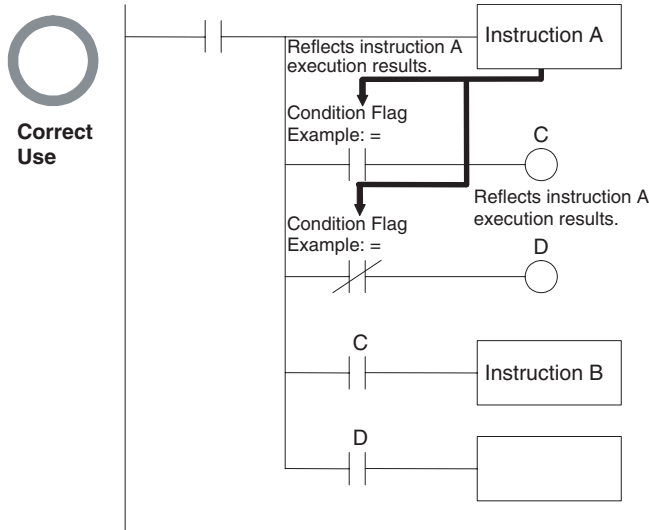

**Example:** The following example will move #0200 to D00200 if D00100 contains #0010 and move #0300 to D00300 if D00100 does not contain #0010.

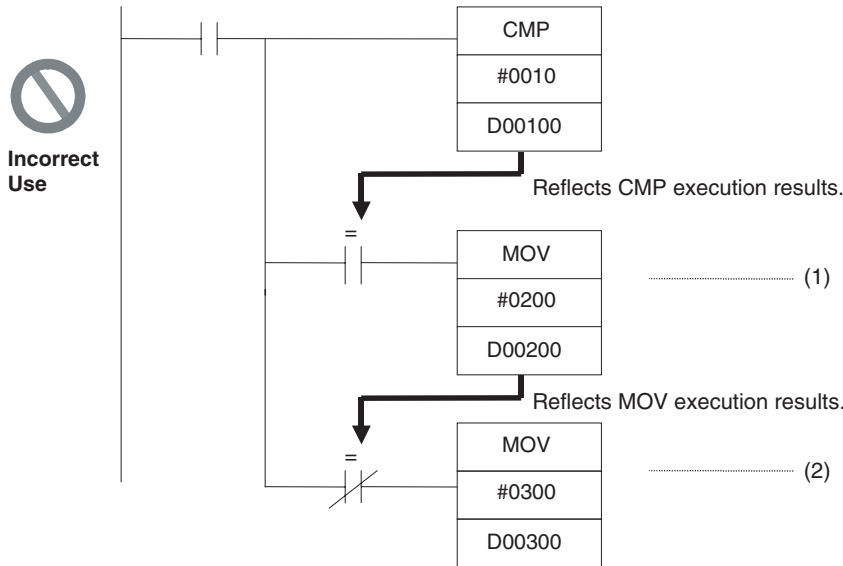

The Equals Flag will turn ON if D00100 in the rung above contains #0010. #0200 will be moved to D00200 for instruction (1), but then the Equals Flag will be turned OFF because the #0200 source data is not 0000 hex. The MOV instruction at (2) will then be executed and #0300 will be moved to D00300. A rung will therefore have to be inserted as shown below to prevent execution results for the first MOVE instruction from being picked up.

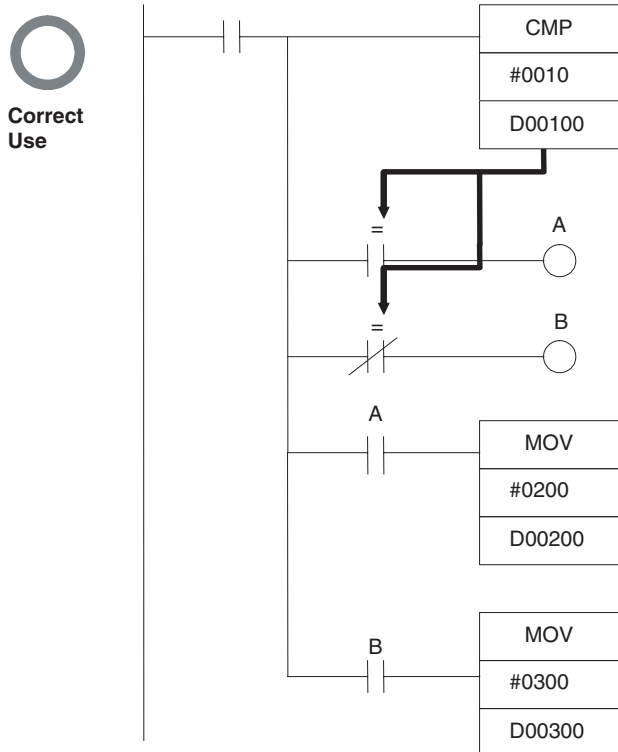

2. **Using Execution Results from Differentiated Instructions**

With differentiated instructions, execution results for instructions are reflected in Condition Flags only when input condition is met, and results for a previous rung (rather than execution results for the differentiated instruction) will be reflected in Condition Flags in the next cycle. You must therefore be aware of what Condition Flags will do in the next cycle if execution results for differentiated instructions to be used.

In the following for example, instructions A and B will execute only if input condition C is met, but the following problem will occur when instruction B picks up execution results from instruction A. If input condition C remains ON in the next cycle after instruction A was executed, then instruction B will unexpectedly execute (by the input condition) when the Condition Flag goes from OFF to ON because of results reflected from a previous rung.

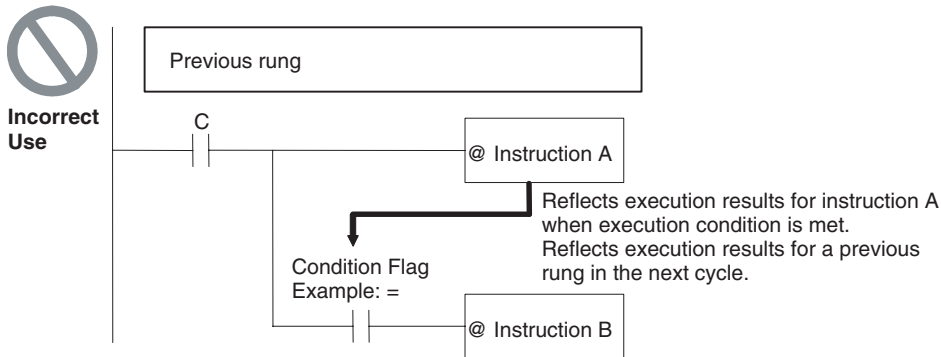

In this case then, instructions A and B are not differentiated instructions, the DIFU(013) (or DIFD(014)) instruction is used instead as shown below and instructions A and B are both upwardly (or downwardly) differentiated and executed for one cycle only.

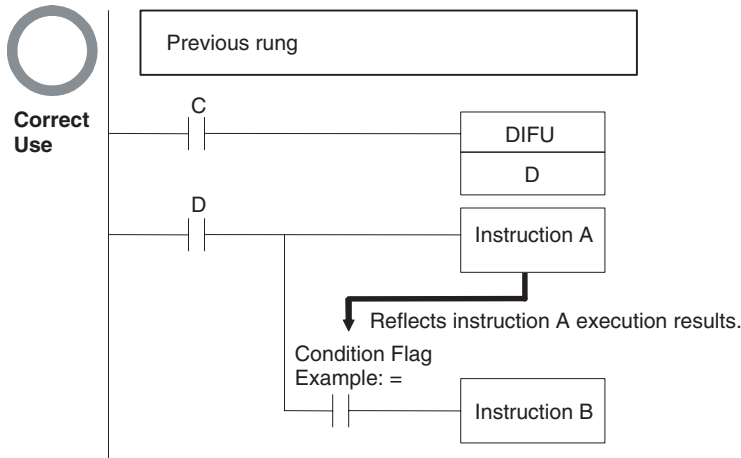

**Main Conditions Turning ON Condition Flags**

**Error Flag**

The ER Flag will turn ON under special conditions, such as when operand data for an instruction is incorrect. The instruction will not be executed when the ER Flag turns ON.

When the ER Flag is ON, the status of other Condition Flags, such as the <, >, OF, and UF Flags, will not change and status of the = and N Flags will vary from instruction to instruction.

Refer to the descriptions of individual instructions in the *Instructions Reference Manual* (O011) for the conditions that will cause the ER Flag to turn ON. Caution is required because some instructions will turn OFF the ER Flag regardless of conditions.

### Equals Flag

The Equals Flag is a temporary flag for all instructions except when comparison results are equal (=). It is set automatically by the system, and it will change. The Equals Flag can be turned OFF (ON) by an instruction after a previous instruction has turned it ON (OFF). The Equals Flag will turn ON, for example, when MOV or another move instruction moves 0000 hex as source data and will be OFF at all other times. Even if an instruction turns the Equals Flag ON, the move instruction will execute immediately and the Equals Flag will turn ON or OFF depending on whether the source data for the move instruction is 0000 hex or not.

### Carry Flag

The CY Flag is used in shift instructions, addition and subtraction instructions with carry input, and addition and subtraction instructions with borrows and carries. Note the following precautions.

1. The CY Flag can remain ON (OFF) because of execution results for a certain instruction and then be used in other instruction (an addition and subtraction instruction with carry or a shift instruction). Be sure to clear the Carry Flag when necessary.
2. The CY Flag can be turned ON (OFF) by the execution results for a certain instruction and be turned OFF (ON) by another instruction. Be sure the proper results are reflected in the Carry Flag when using it.

### Less Than and Greater Than Flags

The < and > Flags are used in comparison instructions.

The < or > Flag can be turned OFF (ON) by another instruction even if it is turned ON (OFF) by execution results for a certain instruction.

### Negative Flag

The N Flag is turned OFF when the leftmost bit of the instruction execution results word is “1” for certain instructions and it is turned OFF unconditionally for other instruction.

### Specifying Operands for Multiple Words

An instruction will be executed as written even if an operand requiring multiple words is specified so that all of the words for the operand are not in the same area. In this case, words will be taken in order of the memory addresses. The Error Flag will **not** turn ON.

As an example, consider the results of executing a block transfer with XFER(070) if 20 words are specified for transfer beginning with W250. Here, the Work Area, which ends at W255, will be exceeded, but the instruction will be executed without turning ON the Error Flag. In the memory addresses, words reserved by the system come after the Work Area, and thus for the following instruction, W250 to W255 will be transferred to D00000 to D00005 and contents of the system-reserved words will be transferred to D00006 to D00019.

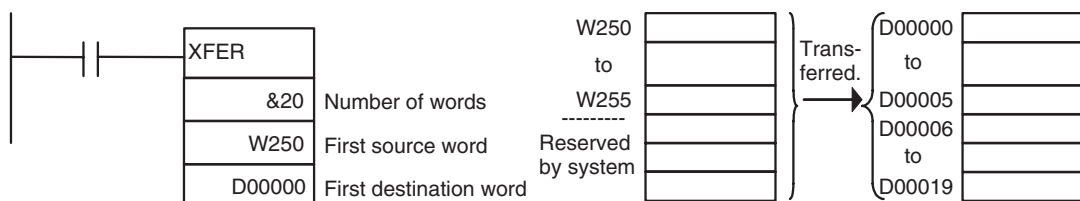

## Special Program Sections

FQM1 programs have special program sections that will control instruction conditions.

The following special program sections are available.

Program section	Instructions	Instruction condition	Status
Subroutine	SBS(091), JSB(982), SBN(092), and RET(093) instructions	Subroutine program being executed.	The subroutine program section between SBN(092) and RET(093) instructions is being executed.
IL(002) - ILC(003) section	IL(002) and ILC(003) instructions	Section is interlocked	The output bits are turned OFF and timers are reset. Other instructions will not be executed and previous status will be maintained.
Step Ladder section	STEP(008) instruction		
Block program section	BPRG(096) instructions and BEND(801) instructions	Block program being executing.	The block program listed in mnemonics between the BPRG(096) and BEND(801) instructions is being executed.

## Instruction Combinations

The following table shows which of the special instructions can be used inside other program sections.

	Subroutine	IL(002) - ILC(003) section	Step ladder section	Block program section
<b>Subroutine</b>	Not possible.	Not possible.	Not possible.	Not possible.
<b>IL(002) - ILC(003)</b>	<b>OK</b>	Not possible.	Not possible.	Not possible.
<b>Step ladder section</b>	Not possible.	<b>OK</b>	Not possible.	Not possible.
<b>Block program section</b>	<b>OK</b>	<b>OK</b>	<b>OK</b>	Not possible.

**Note** Instructions that specify program areas cannot be used between two different tasks.

## Subroutines

Place all the subroutines together just before the END(001) instruction in all programs but after programming other than subroutines. A subroutine cannot be placed in a step ladder, block program, or other subroutine. If instructions other than a subroutine program are placed after a subroutine program (SBN(092) to RET(093)), those instructions will not be executed.

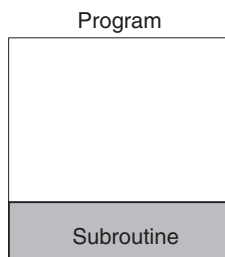
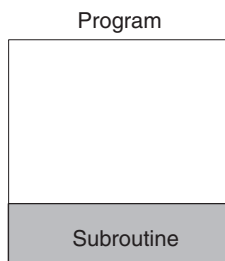

### Instructions Not Allowed in Subroutines

The following instructions cannot be placed in a subroutine.

Function	Mnemonic	Instruction
Ladder Step Control	STEP(008)	Define step ladder section
	SNXT(009)	Step through the step ladder

#### Note Block Program Sections

A subroutine can include a block program section.

### Instructions Not Allowed in Step Ladder Program Sections

Function	Mnemonic	Instruction
Sequence Control	END(001)	END
	IL(002) and ILC(003)	INTERLOCK and INTERLOCK CLEAR
	JMP(004) and JME(005)	JUMP and JUMP END
Subroutines	SBN(092) and RET(093)	SUBROUTINE ENTRY and SUBROUTINE RETURN
Block Programs	IF(802) (NOT), ELSE(803), and IEND(804)	Branching instructions
	BPRG(096) and BEND(801)	BLOCK PROGRAM BEGIN/END

**Note** A step ladder program section can be used in an interlock section (between IL(002) and ILC(003)). The step ladder section will be completely reset when the interlock is ON.

### Instructions Not Allowed in Block Program Sections

The following instructions cannot be placed in block program sections.

Classification by Function	Mnemonic	Instruction
Sequence Control	IL(002) and ILC(003)	INTERLOCK and INTERLOCK CLEAR
	END(001)	END
Sequence Output	DIFU(013)	DIFFERENTIATE UP
	DIFD(014)	DIFFERENTIATE DOWN
	KEEP(011)	KEEP
	OUT	OUTPUT
	OUT NOT	OUTPUT NOT
Timer/Counter	TIM	TIMER
	TIMH	HIGH-SPEED TIMER
	TMHH(540)	ONE-MS TIMER
	CNT	COUNTER
	CNTR	REVERSIBLE COUNTER
Subroutines	SBN(092) and RET(093)	SUBROUTINE ENTRY and SUBROUTINE RETURN
Data Shift	SFT(010)	SHIFT
Ladder Step Control	STEP(008) and SNXT(009)	STEP DEFINE and STEP START
Block Program	BPRG(096)	BLOCK PROGRAM BEGIN

- Note**
- (1) Block programs can be used in a step ladder program section.
  - (2) A block program can be used in an interlock section (between IL(002) and ILC(003)). The block program section will not be executed when the interlock is ON.
  - (3) A JUMP instruction (JMP(004)) can be used in a block program section, but the JUMP (JMP(004)) and JUMP END (JME(005)) instructions must be used in a pair within the block program section. The program will not execute properly unless these instructions are paired.

# Computing the Cycle Time

## FQM1 Operation Flowchart

The Coordinator Module and Motion Control Modules process data in repeating cycles from the overseeing processing up to peripheral servicing as shown in the following diagram.

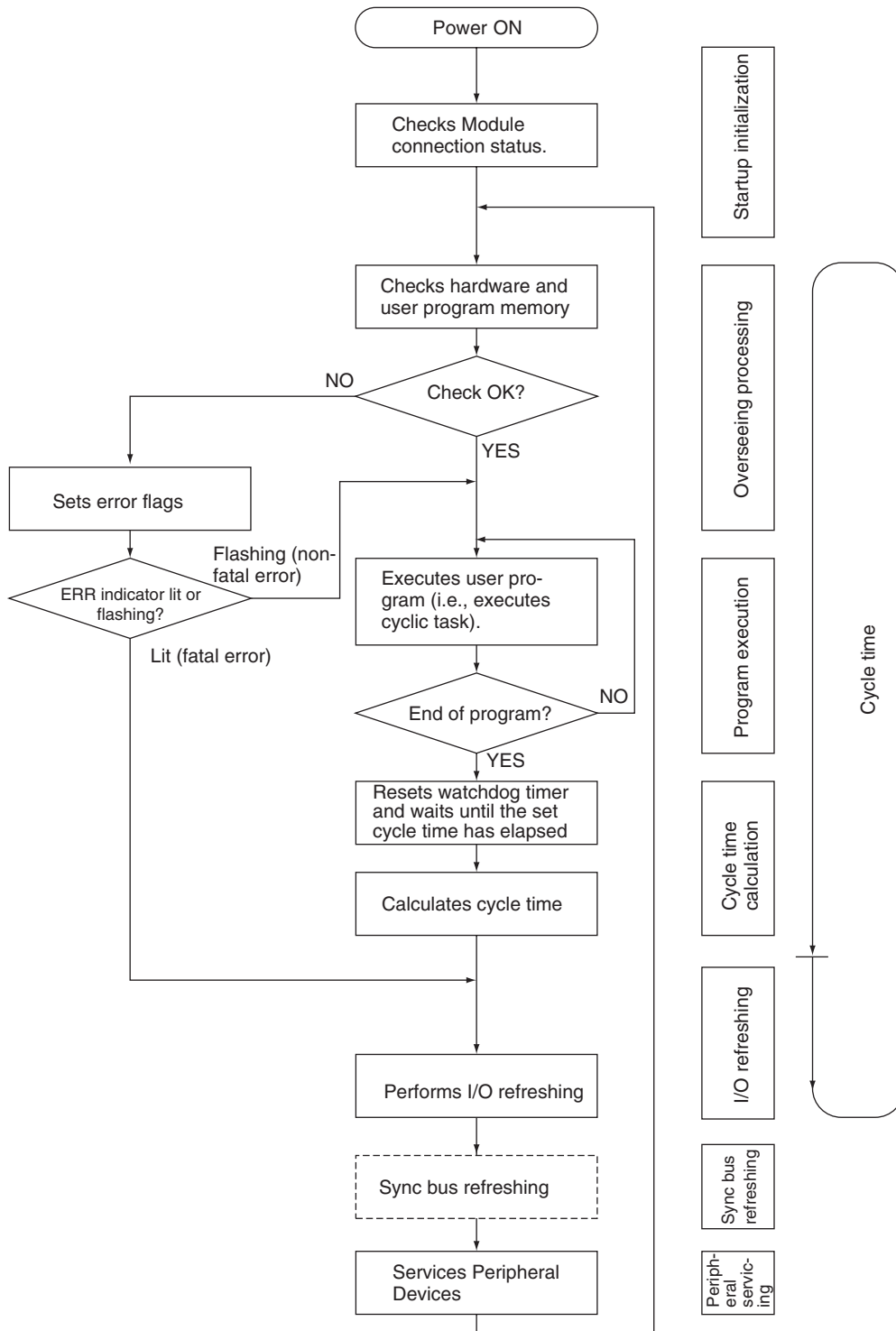



## Overview of Cycle Time Calculations

### Coordinator Module

The cycle time of the Coordinator Module will vary with the following factors.

- Type and number of instructions in the user programs (in the cyclic task and within interrupt tasks for which the execution conditions have been satisfied)
- Type and number of Motion Control Modules
- Setting a constant cycle time in the System Setup
- Event servicing with the Motion Control Modules
- Use of peripheral, RS-232C, and RS-422A ports
- Setting the *Set Time to All Events* in the System Setup

- Note** (1) The cycle time is not affected by the number of tasks that are used in the user program.  
 (2) When the mode is switched from MONITOR mode to RUN mode, the cycle time will be extended by 10 ms (this will not, however, will not create a cycle time exceeded error).

### Motion Control Modules

The cycle time of the Motion Control Module will vary with the following factors.

- Type and number of instructions in the user programs (in the cyclic task and within interrupt tasks for which the execution conditions have been satisfied)
- Setting a constant cycle time in the System Setup
- Event servicing with the Coordinator Module

- Note** (1) The cycle time is not affected by the number of tasks that are used in the user program.  
 (2) When the mode is switched from MONITOR mode to RUN mode, the cycle time will be extended by 10 ms (this will not, however, will not create a cycle time exceeded error).

### Calculating the Cycle Time of the Coordinator Module

The cycle time is the total time required for the Coordinator Module to perform the operations shown in the following tables.

Cycle time = (1) + (2) + (3) + (4) + (5) + (6) + (7)

#### 1. Overseeing Process

Details	Processing time and fluctuation cause
Checks the buses, user program memory, etc.	39 $\mu$ s

#### 2. Program Execution

Details	Processing time and fluctuation cause
Executes the user program. This is the total time taken for the instructions to execute the program.	40 $\mu$ s + total instruction execution time

#### 3. Cycle Time Calculation

Details	Processing time and fluctuation cause
Waits for the specified cycle time to elapse when a constant (minimum) cycle time has been set in the System Setup. Calculates the cycle time.	Cycle time calculation: 8 $\mu$ s Waiting time for a constant cycle time = Set cycle time – Actual cycle time

#### 4. I/O Refreshing

Details	Processing time and fluctuation cause
The built-in I/O on the Coordinator Module are refreshed.	5 $\mu$ s Coordinator Module I/O refresh time

## 5. Sync Bus Refreshing

Details	Processing time and fluctuation cause
The sync bus between the Coordinator Module and Motion Control Modules is refreshed.	Async Mode: 0 $\mu$ s Sync Mode: 170 $\mu$ s min. (depends on number of Motion Control Modules)

## 6. Cyclic Refreshing

Details	Processing time and fluctuation cause
The allocated bit areas are refreshed.	4 $\mu$ s + Cyclic refresh time (40 $\mu$ s) x Number of Motion Control Modules

## 7. Peripheral Service

Details	Processing time and fluctuation cause
Peripheral service overhead: 76 $\mu$ s Event servicing with Motion Control Modules <b>Note</b> Does not include I/O refreshing.	If a uniform peripheral servicing time hasn't been set as the <i>Set Time to All Events</i> in the System Setup, 6.25% of the previous cycle time (calculated in step (3)) will be allowed for peripheral servicing. If a uniform peripheral servicing time has been set in the System Setup, servicing will be performed for the set time. At least 0.1 ms, however, will be serviced whether the peripheral servicing time is set or not. If no Modules are connected, the servicing time is 0 ms.
Peripheral port servicing	If a uniform peripheral servicing time hasn't been set as the <i>Set Time to All Events</i> in the System Setup, 6.25% of the previous cycle time (calculated in step (3)) will be allowed for peripheral servicing. If a uniform peripheral servicing time has been set in the System Setup, servicing will be performed for the set time. At least 0.1 ms, however, will be serviced whether the peripheral servicing time is set or not. If the port is not connected, the servicing time is 0 ms.
RS-232C port servicing	Same as for peripheral port servicing.
RS-422A port servicing	If a uniform peripheral servicing time hasn't been set as the <i>Set Time to All Events</i> in the System Setup, 6.25% of the previous cycle time (calculated in step (3)) will be allowed for peripheral servicing. If a uniform peripheral servicing time has been set in the System Setup, servicing will be performed for the set time. At least 0.1 ms, however, will be serviced whether the peripheral servicing time is set or not. If the communications port is not used, the servicing time is 0 ms.

**Calculating the Cycle Time of a Motion Control Module**

The cycle time is the total time required for the Motion Control Module to perform the operations shown in the following tables.

$$\text{Cycle time} = (1) + (2) + (3) + (4) + (5) + (6) + (7)$$

## 1. Overseeing Process

Details	Processing time and fluctuation cause
User program check, etc.	29 $\mu$ s

## 2. Program Execution

Details	Processing time and fluctuation cause
Executes the user program. This is the total time taken for the instructions to execute the program.	40 $\mu$ s + total instruction execution time

## 3. Cycle Time Calculation

Details	Processing time and fluctuation cause
Waits for the specified cycle time to elapse when a constant (minimum) cycle time has been set in the System Setup. Calculates the cycle time.	Cycle time calculation: 8 $\mu$ s Waiting time for a constant cycle time = Set cycle time – Actual cycle time (1 + 2 + 4 + 5)

4. I/O Refreshing

Details	Processing time and fluctuation cause
The built-in I/O and special inputs (pulse/analog) on the Motion Control Module are refreshed.	MMP21: 48 $\mu$ s MMA21: 135 $\mu$ s Motion Control Module I/O refresh time

5. Cyclic Refreshing

Details	Processing time and fluctuation cause
Cyclic refresh with the Coordinator Module	21 $\mu$ s

6. Sync Bus Refreshing

Details	Processing time and fluctuation cause
The sync bus between the Coordinator Module and Motion Control Modules is refreshed.	60 $\mu$ s

7. Peripheral Service

Details	Processing time and fluctuation cause
Event servicing with Motion Control Modules	40 $\mu$ s + Event service time Event service time includes event servicing for DM area transfers requested by the Coordinator Module, event processing for requests from the CX-Programmer, etc.

## Module I/O Refresh Times

### Cyclic Refresh Time in the Coordinator Module

Model	I/O refresh time
FQM1-MMP21/MMA21	40 $\mu$ s per Module

### Cyclic Refresh Time in Motion Control Modules

Model	I/O refresh time
FQM1-MMP21/MMA21	21 $\mu$ s

## Example of Calculating the Cycle Time

An example is given here for FQM1-MMP21 Motion Control Modules connected to a Coordinator Module.

### Conditions

Item	Condition	
Motion Control Modules	FQM1-MMP21	2 Modules
User program	5 Ksteps	LD: 2.5 Ksteps OUT: 2.5 Ksteps
Peripheral port connection	None	
Constant cycle time setting	None	
RS-232C port connection	None	
RS-422A port connection	None	
Other peripheral servicing	None	

### Calculation Example for FQM1-MMP21

Process	Calculation	Processing time
		Without CX-Programmer connected to peripheral port
1. Overseeing	---	0.029 ms
2. Program execution	$40 \mu\text{s} + 0.1 \mu\text{s} \times 500 + 0.35 \mu\text{s} \times 500$	0.265 ms
3. Cycle time calculation	(No cycle time set)	0.008 ms
4. I/O refresh		0.048 ms
5. Cyclic refresh		0.021 ms
6. Sync bus Refresh		(In Async Mode: 0 ms)
7. Peripheral servicing		0.04 ms
Cycle time	1. + 2. + 3. + 4. + 5. + 7.	0.411 ms

## Online Editing Cycle Time Extension

When online editing is executed from the CX-Programmer while the FQM1 is operating in MONITOR mode to change the program, the Coordinator Module will momentarily suspend operation while the program is being changed. The period of time that the cycle time is extended is determined by the following conditions.

- The number of steps that is changed
- Editing operations (insert/delete/overwrite)
- Instructions used

The cycle time extension for online editing will be negligibly affected by the size of largest task program. If the maximum program size for each task is 5 Ksteps, the online editing cycle time extension will be as shown in the following table.

Module	Online editing cycle time extension
FQM1-CM001	65 ms max., 14 ms typical (for a program size of 5 Ksteps)
FQM1-MMP21/MMA21	

When editing online, the cycle time will be extended by the above time.

**Note** When there is only one task, online editing is processed entirely in the cycle time following the cycle in which online editing is executed. When there are multiple tasks (cyclic task and interrupt tasks), online editing is separated, so that for n tasks, processing is executed over n to  $n \times 2$  cycles max.

## Response Time

### I/O Response Time

The I/O response time is the time it takes from when an built-in input on a Module turns ON, the data is recognized by the Module, and the user program is executed, up to the time for the result to be output to the built-in output terminals. The length of the I/O response time depends on the following conditions.

- Timing of input bit turning ON
- Cycle time

### Coordinator Module I/O Response Time

#### Minimum I/O Response Time

The I/O response time is shortest when data is retrieved immediately before I/O refresh of the Coordinator Module. The minimum I/O response time is the total of the Input ON delay, the Cycle time, and the Output ON delay.

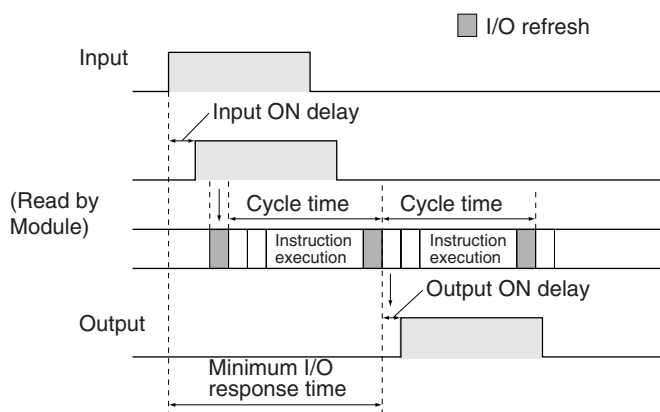

#### Maximum I/O Response Time

The I/O response time is longest when data is retrieved immediately after I/O refresh of the Coordinator Module. The maximum I/O response time is the total of the Input ON delay, (the Cycle time × 2), and the Output ON delay.

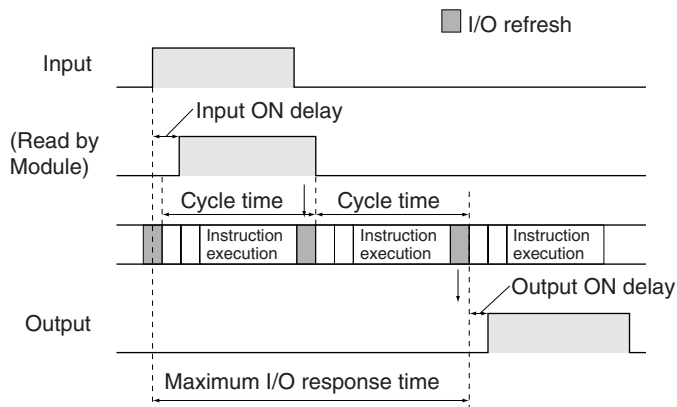

#### Calculation Example

Conditions: Input ON delay: 0.1 ms  
 Output ON delay: 0.1 ms  
 Cycle time: 2 ms

Minimum I/O response time = 0.1 ms + 2 ms + 0.1 ms = 2.2 ms

Maximum I/O response time = 0.1 ms + (2 ms × 2) + 0.1 ms = 4.2 ms

### Motion Control Module I/O Response Time

#### Minimum I/O Response Time (General-purpose I/O 0 to 3)

The I/O response time is shortest when the input refresh is executed immediately after a Motion Control Module detects an input, as shown in the figure below.

The minimum I/O response time is the total of the Input ON delay, the Cycle time, and the Output ON delay.

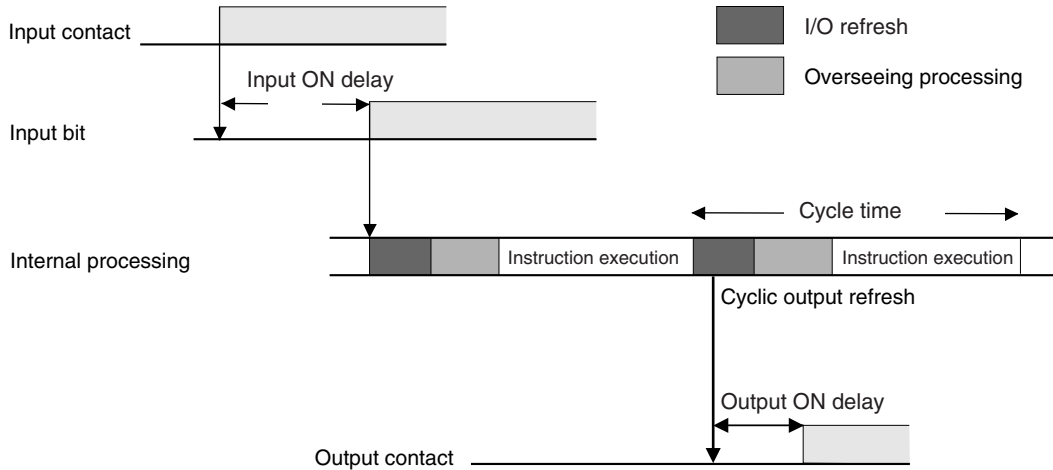

- Cyclic Output Refresh Time  
Minimum I/O response time = 0.03 + 0.194 + 0.1 = 0.324 (ms)

**Note** Input interrupts and the IORF(097) instruction can be used to obtain a faster response (100 μs typical).

#### Maximum I/O Response Time

The I/O response time is longest when a Motion Control Module detects an input immediately after input refresh has been executed, as shown in the figure below. The response time will be one cycle longer than for the minimum I/O response time.

The maximum I/O response time is the total of the Input ON delay, (the Cycle time × 2), and the Output ON delay.

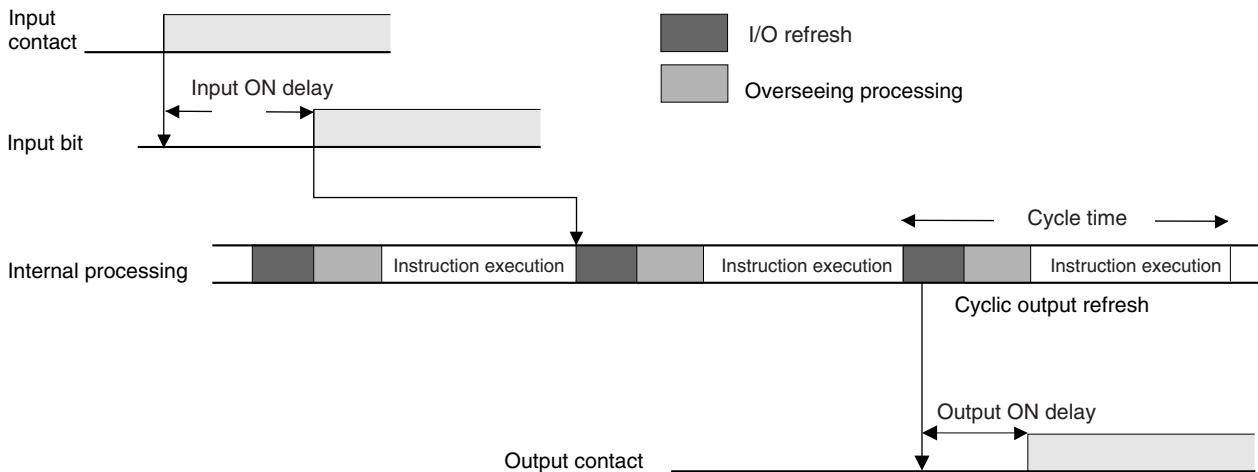

- Cyclic Output Refresh Time  
Maximum I/O response time = 0.03 + 0.388 + 0.1 = 0.518 (ms)

**Calculation Example**

Input ON delay: 0.03 ms  
 Overhead time: 0.193 ms  
 Instruction execution time: 0.001 ms  
 Output ON delay: 0.1 ms  
 Position of OUT: Beginning of program.

**I/O Response Time for Pulse and Analog I/O**

As shown in the following diagram, an MPU in the Motion Control Module directly controls pulse and analog I/O processing with hardware. The cycle time for pulse and analog I/O is thus included in the cycle time of a Motion Control Module. Hardware control means that the most recent data is handled for this I/O.

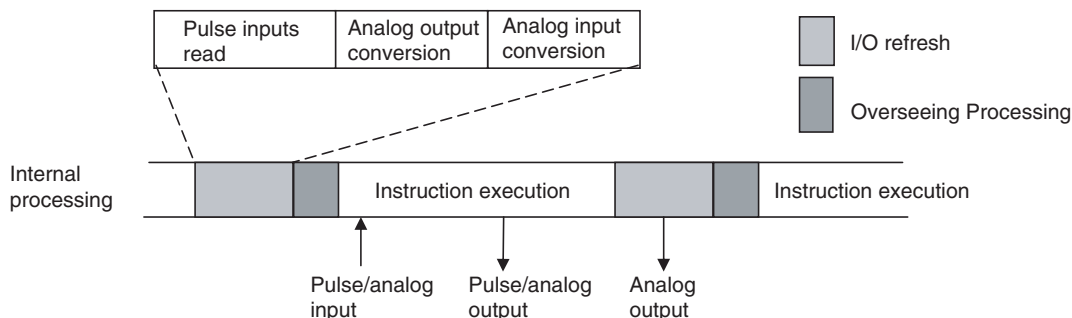

The pulse and analog input data read with the I/O refresh in one cycle will thus be used immediately and can be output from the ladder program in the next cycle.

**Interrupt Response Times**

**Motion Control Module Interrupt Response Times**

**Input Interrupt Tasks**

The interrupt response time for an input interrupt task is the time required from when a built-in input on a Motion Control Module turns ON (upward differentiation) or turns OFF (downward differentiation) until the input interrupt task is actually executed. The interrupt response time for an input interrupt task would be the total of the hardware and software response times given in the following table.

- Response Times for Built-in Inputs

Item	Description
Hardware response time	Upward differentiation: 0.03 ms Downward differentiation: 0.2 ms
Software response time	72 to 82 μs (See note 2.)

- Note**
- (1) Input interrupt tasks can be executed during execution of the user program, I/O refresh, peripheral servicing, or overseeing processes. (During user program execution, instruction execution is suspended to execute the interrupt task.) The response time is not affected by the type of process being executed when the input interrupt is generated. An input interrupt task, however, will not be executed immediately if another interrupt task is already being executed. Execution of the next interrupt task will wait until the current interrupt task has completed execution and then interrupt tasks will be executed in order of priority after the Software interrupt response time.
  - (2) For the FQM1-MMA21, interrupt processing is prohibited during analog I/O conversion. A minimum of 72 to 130 μs will be required.
  - (3) If an interrupt occurs during an instruction that is processed using hardware, interrupt task execution will be postponed until the instruction has finished execution. A minimum of 10 μs will be required.

The interrupt response time for an input interrupt task is shown below.

$$\text{Input interrupt response time} = \text{Input ON delay} + \text{Software interrupt response time}$$

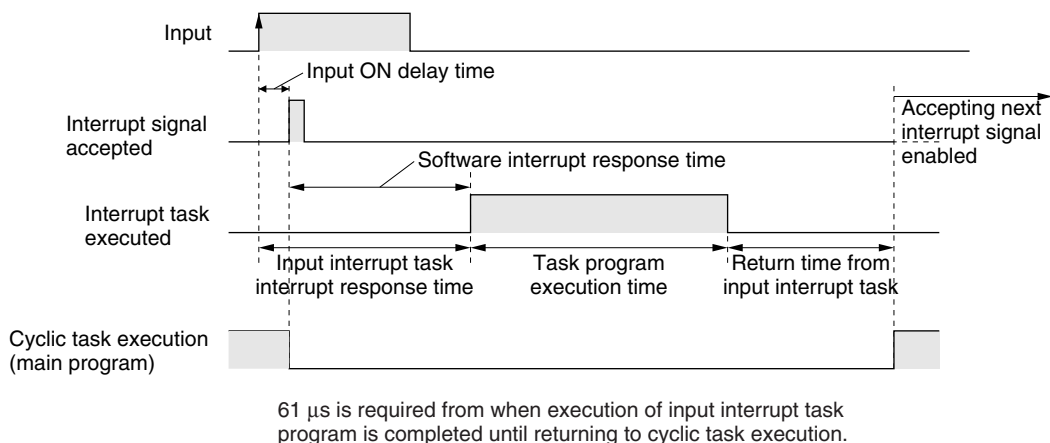

### Scheduled Interrupt Task

The interrupt response time of scheduled interrupt tasks is the time taken from after the scheduled time specified by the STIM(980) instruction has elapsed until the interrupt task is actually executed. The maximum interrupt response time for scheduled interrupt tasks is 0.1 ms.

Also, a dedicated timer is used for the specified scheduled interrupt time (minimum of 0.5 ms), so there is essentially no error in the time.

**Note** Scheduled interrupt tasks can be executed during execution of the user program, I/O refresh, peripheral servicing, or overseeing processes. (During user program execution, instruction execution is suspended to execute the interrupt task.) The response time is not affected by the type of process being executed when the input interrupt is generated. A schedule interrupt task, however, will not be executed immediately if another interrupt task is already being executed. Execution of the next scheduled interrupt task will wait until the current interrupt task has completed execution and then start after the software interrupt response time.

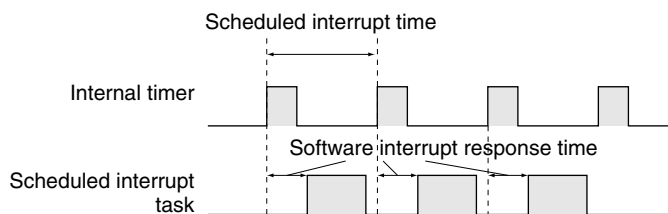

### Motion Control Module Interrupt Processing Times

This section describes the processing time required to generate the interrupt and call the interrupt task, and the processing time to return to the original location after completing the interrupt task. This information applies to the following four types of interrupt.

- Input interrupts
- Interval timer interrupts
- High-speed counter interrupts
- Pulse output interrupts



**Processing Time**

The time required from when the interrupt factor occurs until the interrupt task is called and the time required from completing the interrupt task until program execution returns to the original position are shown below.

	Item	Description	Time
1	Interrupt input ON delay	This is the additional time required from when the interrupt input contact turns ON until the interrupt is generated. This time applies only to input interrupts.	30 $\mu$ s
	↓ Interrupt condition established		
2	Waiting for interrupt prohibition to be released	Time may be required to wait for interrupt prohibition to be released. See below for details.	See below.
	↓		
3	Switchover time	This is the time required to switch over to interrupt processing.	72 $\mu$ s
	↓ Interrupt processing routine executed		
	↓		
4	Return	This is the time from the END(001) in the interrupt task until returning to the process that was being performed when the interrupt occurred.	61 $\mu$ s

- Online Editing: If online editing is performed during operation, operation will be stopped for a maximum of 65 ms, during which time interrupts will be prohibited and the program will be overwritten.
- Data Exchange with Coordinator Module: Interrupts will be prohibited for 10  $\mu$ s when data is exchanged with the Coordinator Module.
- Analog I/O Refreshing: Interrupts will be prohibited for approximately 40  $\mu$ s while analog conversion is being performed for analog I/O.
- Hardware-supported Instructions: Some FQM1 ladder instructions are implemented using hardware. Interrupts will be placed on standby during execution of hardware-supported instructions that require time to process, such as XFER(070) and BSET(071).

**Interrupt Response Time Calculation Example**

The interrupt response times from the interrupt input turning ON until the interrupt task is started for when an input interrupt occurs under the following conditions are given below.

- No 1-ms timers are being used.
- No non-fatal errors occur or are cleared.
- Online editing is not performed.

**Minimum Response Time**

Interrupt input ON delay:	10 $\mu$ s
Interrupt prohibition release time:	0 $\mu$ s
+ Switchover time:	<u>72 <math>\mu</math>s</u>
Total: Minimum response time:	82 $\mu$ s

**Maximum Response Time**

Interrupt input ON delay:	30 $\mu$ s
Interrupt prohibition release time:	10 $\mu$ s
+ Switchover time:	<u>72 <math>\mu</math>s</u>
Total: Minimum response time:	112 $\mu$ s

**Note** (1) To return to the process being performed before the interrupt occurred, the execution time of the interrupt task and 61  $\mu$ s are required in addition to the above response time.

- (2) When using interrupt tasks frequently, be sure to consider the time required for interrupt processing and its affect on the overall system.
- (3) The results of executing an interrupt task can be output immediately from within the interrupt task by using the IORF(097) instruction. (This can also be performed to output the results of execution in the main program immediately after execution.)
- (4) The results of executing an interrupt task can be output immediately from within the interrupt task by selecting *Immediate refresh* in the System Setup and then using the SPED(885) and ACC(888) instructions. (This can also be performed to output the results of execution in the main program immediately after execution.)

# Appendix B

## I/O Memory

### Overview of I/O Memory

#### Introduction

This section describes the I/O Memory and other parts of memory in the Modules other than that containing the user program.

#### I/O Memory

This region of memory contains the data areas which can be accessed by instruction operands. The data areas include the CIO Area, Work Area, Auxiliary Area, DM Area, Timer Area, Counter Area, Index Registers, Condition Flag Area, and Clock Pulse Area.

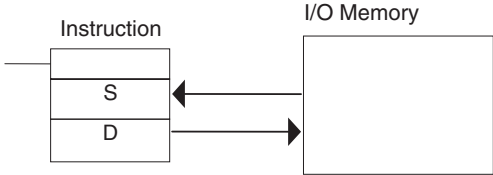

#### Parameter Area

This region of memory contains various settings that cannot be specified by instruction operands; they can be specified from the CX-Programmer only. The settings include the System Setup.

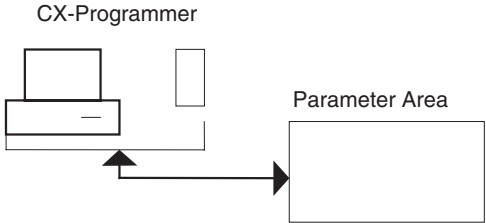

# I/O Memory Structure

## Coordinator Module

The following table shows the basic structure of the I/O Memory for the Coordinator Module.

Area		Size	Range	Task usage	External I/O allocation	Bit access	Word access	Access		Change from CX-Programmer	Status at power ON	Status at mode change	Forcing bit status	
								Read	Write					
CIO Area	I/O Area	24 bits (2 words)	CIO 0000 to CIO 0001	Shared by all tasks	OK Coordinator Module	OK	OK	OK	OK	OK	Cleared	Cleared	OK	
	Serial PLC Link Area	320 bits (20 words)	CIO 0080 to CIO 0099		---	OK	OK	OK	OK	OK			OK	OK
	Cyclic Refresh Bit Area	600 bits (40 words)	CIO 0100 to CIO 0139		---	OK	OK	OK	OK	OK			OK	OK
	Synchronous Data Link Bit Area	320 bits (20 words)	CIO 0200 to CIO 0219		---	OK	OK	OK	OK	OK			OK	OK
	Internal I/O Areas	2,784 bits (174 words)	CIO 0002 to CIO 0079 CIO 0140 to CIO 0199 CIO 0220 to CIO 0255		---	OK	OK	OK	OK	OK			OK	OK
Work Area		4,096 bits (256 words)	W000 to W255	---	OK	OK	OK	OK	OK	OK	Cleared	Cleared	OK	
Auxiliary Area		10,400 bits (650 words)	A000 to A649	---	OK	OK	OK	OK	OK	OK	Cleared	Maintained	No	
TR Area		16 bits	TR0 to TR15	---	OK	---	OK	OK	No	No	Cleared	Cleared	No	
DM Area		30,000 words	D00000 to D29999	---	No	OK	OK	OK	OK	OK	Cleared	Maintained	No	
		2,768 words	D30000 to D32767	---	No	OK	OK	OK	OK	OK	Maintained (See note.)	Maintained	No	
Timer Area		256 words	T0000 to T0255	---	OK	---	OK	OK	OK	OK	Cleared	Cleared	OK	
Counter Area		256 words	C0000 to C0255	---	OK	---	OK	OK	OK	OK	Cleared	Maintained	OK	

**Note** When data is written from the CX-Programmer or a host controller, these DM Area words are backed up in flash memory. The contents of flash memory is read out each time the power is turned ON.

## Motion Control Modules

The following table shows the basic structure of the I/O Memory Area for the Motion Control Modules.

Area		Size	Range	Task usage	External I/O allocation	Bit access	Word access	Access		Change from CX-Programmer	Status at power ON	Status at mode change	Forcing bit status	
								Read	Write					
CIO Area	I/O Area	20 bits (2 words)	CIO 0000 to CIO 0001	Shared by all tasks	OK Motion Control Module	OK	OK	OK	OK	OK	Cleared	Cleared	OK	
	Cyclic Refresh Bit Area	160 bits (10 words)	CIO 0100 to CIO 0109		---	OK	OK	OK	OK	OK			OK	OK
	Synchronous Data Link Bit Area	320 bits (20 words)	CIO 0200 to CIO 0219		---	OK	OK	OK	OK	OK			OK	OK
	Internal I/O Areas	3,584 bits (224 words)	CIO 0002 to CIO 0099 CIO 0110 to CIO 0199 CIO 0220 to CIO 0255		---	OK	OK	OK	OK	OK			OK	OK
Work Area		4,096 bits (256 words)	W000 to W255	---	OK	OK	OK	OK	OK	OK	Cleared	Cleared	OK	
Auxiliary Area		10,400 bits (650 words)	A000 to A649	---	OK	OK	OK	OK	OK	OK	Cleared	Maintained	No	
TR Area		16 bits	TR0 to TR15	---	OK	---	OK	OK	No	No	Cleared	Cleared	No	
DM Area		30,000 words	D00000 to D29999	---	No	OK	OK	OK	OK	OK	Cleared	Maintained	No	
		2,768 words	D30000 to D32767	---	No	OK	OK	OK	OK	OK	Maintained (See note.)	Maintained	No	
Timer Area		256 words	T0000 to T0255	---	OK	---	OK	OK	OK	OK	Cleared	Cleared	OK	
Counter Area		256 words	C0000 to C0255	---	OK	---	OK	OK	OK	OK	Cleared	Maintained	OK	

**Note** These DM Area words are backed up by a super capacitor. If the Memory Not Held Flag (A404.14) is ON, these words are cleared to all zeros.

## CIO Area

### Overview

It is not necessary to input the “CIO” prefix when specifying an address in the CIO Area. The CIO Area is generally used for data exchanges, such as I/O refreshing between Modules (Coordinator Module and Motion Control Modules). Words that are not allocated to Modules may be used as work words and work bits in the program only.

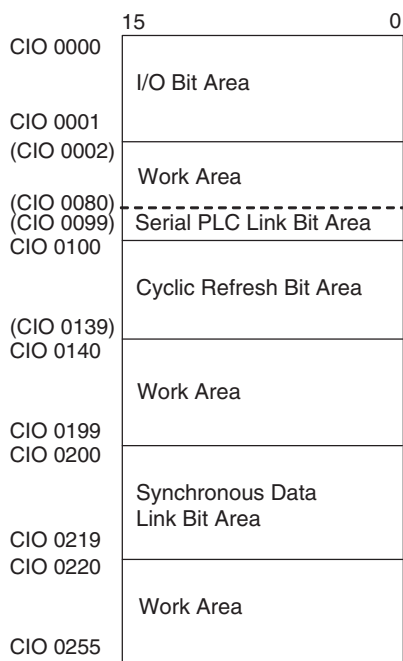

**Note** The above figure depicts the CIO Area of the Coordinator Module. For the Motion Control Module, the following area ranges are different.

- Serial PLC Link Bit Area: Not provided
- Cyclic Refresh Bit Area: CIO 0100 to CIO 0109
- Work Area: CIO 0002 to CIO 0099  
CIO 0110 to CIO 0199

The CIO Area includes the following four areas.

- I/O Bit Area
- Cyclic Refresh Bit Area
- Synchronous Data Link Bit Area
- Work Areas
- Serial PLC Link Bit Areas (Coordinator Module only)

### **I/O Bit Area: CIO 0000 and CIO 0001**

These words are allocated to built-in I/O terminals the Coordinator Module or Motion Control Module.

### **Cyclic Refresh Bit Area: CIO 0100 to CIO 0139 (CIO 0100 to CIO 0109 for Motion Control Modules)**

In the Coordinator Module, 10 words are refreshed every cycle for each Motion Control Module. These words contain Motion Control Module status, general-purpose I/O, and other information. (Refreshing these words is not necessarily synchronized with the Motion Control Module Cycles.)

This area can be used to transfer information between Modules that does not required high-speed exchange. The user can allocate the information to be transferred and the information can be used accessed from the ladder programs in the Coordinator Module and Motion Control Modules to coordinate programming.

**Synchronous Data Link Bit Area: CIO 0200 to 0219**

Each Module (Coordinator Module and Motion Control Modules) broadcasts up to two items (four words) of data at the specified cycle. The data can be specified separately for each Module and is allocated for this area. All of the linked Modules can access the data that is broadcast by other Modules.

**Work Areas: CIO 0002 to CIO 0079, CIO 0140 to CIO 0199, and CIO 0220 to CIO 0255 (CIO 0002 to CIO 0099, CIO 0110 to CIO 0199, and CIO 0220 to CIO 0255 for Motion Control Modules)**

These words can be used only in the program; they cannot be used for I/O exchange with external I/O terminals. Be sure to use the work words provided in the Work Area before allocating words in the Internal I/O Areas.

**Serial PLC Link Bit Area: CIO 0080 to CIO 0099**

These words are allocated for use with the Serial PLC Link, for data links with a PLC.

- CIO 0080 to (CIO 0080 + No. of linked words – 1): CJ1M to FQM1 Coordinator Module
- CIO 0090 to (CIO 0090 + No. of linked words – 1): FQM1 Coordinator Module to CJ1M

Addresses not used for Serial PLC Link can be used only in the program, the same as the Work Area.

**I/O Refresh**

The ON/OFF status of external devices and I/O bits is updated during the I/O refresh. In doing so, the ON/OFF status of external devices, such as pushbuttons, limit switches, photoelectric sensors, and other input devices is reflected in the input bits in the I/O Area (CIO 0000). Also, the status of output bits in the I/O Area (CIO 0001) is output to actuators and other external devices.

There are two methods that can be used for the I/O refresh.

**END Refresh**

With an END refresh, all I/O is refreshed once every cycle after the entire user program has been executed.

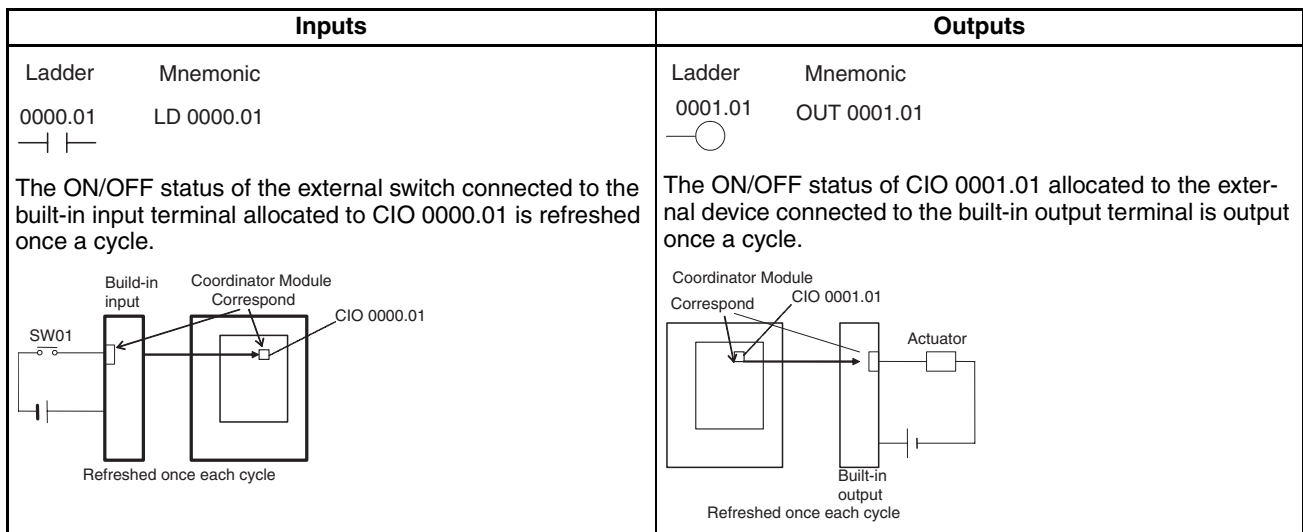

## Immediate Refresh

I/O can also be refreshed on the timing specified by the user using immediate refreshing. Any I/O refreshed using an immediate refresh will also be refreshed for the END refresh.

### Refreshing Using the IORF(097) Instruction

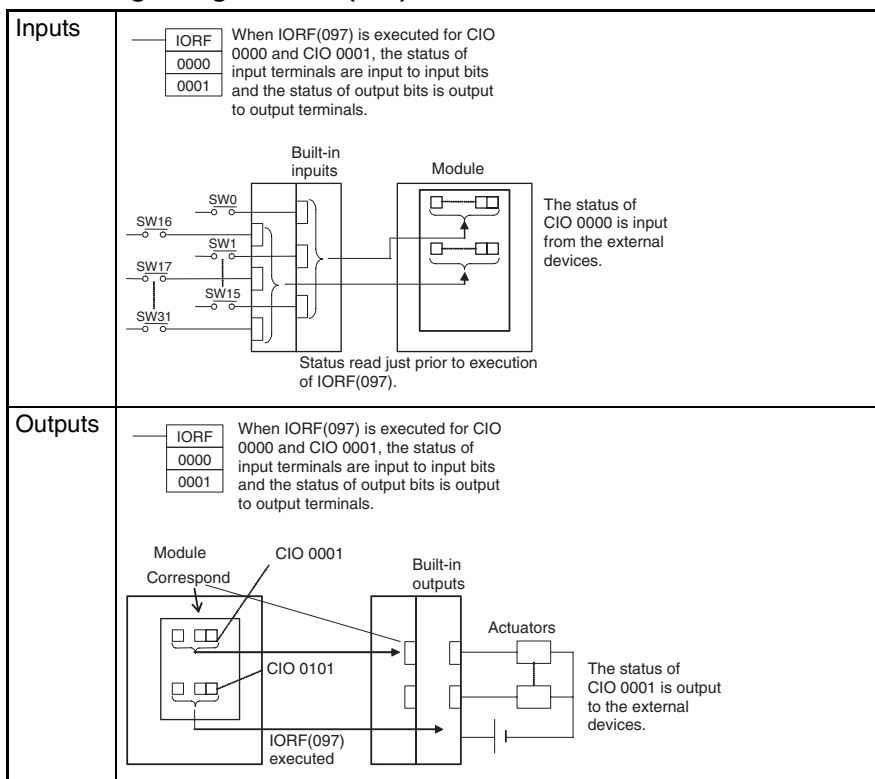

## Work Area: W000 to W255 (W000.00 to W255.15), 4,096 Bits

Words in the Work Area can be used only in the program; they cannot be used for I/O exchange with external I/O terminals. Use this area for work words and bits before any other words in the CIO Area.

## Auxiliary Area: A000 to A649 (A000.00 to A649.15)

The Auxiliary Area contains flags (controlled by the system) and control bits (controlled by the user) used to monitor and control FQM1 operation. The functions of these flags and bits are predetermined and include error flags from self-diagnosis, initial settings, operation controls, and operation status monitor data.

The bits and words in this area can be read and written from the program or from the CX-Programmer.

The bits in this area cannot be force-set or force-reset continuously;

The CX-Programmer read/write operations include setting and resetting bits online (not forced), changing present values from address monitor displays, and transfer operations to the FQM1 after editing FQM1 data tables on the CX-Programmer. Refer to the *CX-Programmer Operation Manual* (Cat. No. W437) for details.

## Temporary Relay Area (TR)

The TR Area contains bits that record the ON/OFF input condition status at program branches. The TR bits are used with mnemonics only.

- TR0 to TR15 can be used in any order and any number of times.
- TR bits can be used only in OUT and LD instructions.
  - OUT instructions (OUT TR0 to OUT TR15) are used to store the input conditions at branch points. LD instructions (LD TR0 to LD TR15) are used to read the input conditions previously stored at branch points.



- Each TR bit can be used only once in one program section.
- The status of TR bits cannot be changed from the CX-Programmer.

TB bits are used in the following cases.

- When there are two outputs with different LD instructions after the last branch point:

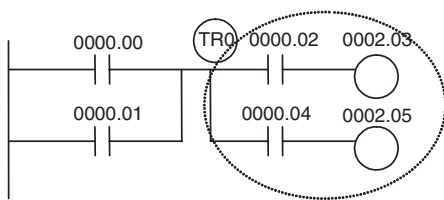

Instruction	Operand
LD	0000.00
OR	0000.01
OUT	TR 0
AND	0000.02
OUT	0002.03
LD	TR 0
AND	0000.04
OUT	0002.05

- When there is no LD instruction on the lower rung after a branch point:

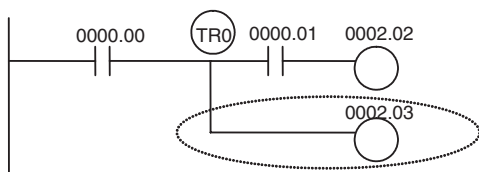

Instruction	Operand
LD	0000.00
OUT	TR 0
AND	0000.01
OUT	0002.02
LD	TR 0
OUT	0002.03

**Note** In the following cases, there are either no LD instructions after the branch points, or any LD instructions are on the bottom rung. TR bits are not required in these types of branches.

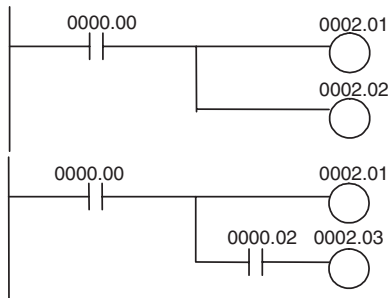

Instruction	Operand
LD	0000.00
OUT	0002.01
OUT	0002.02

Instruction	Operand
LD	0000.00
OUT	0002.01
AND	0000.02
OUT	0002.03

## Timer Area

The 256 timer numbers (T0000 to T0255) are shared by the TIM, TIMH(015), and TMHH(540) instructions. Timer Completion Flags and present values (PVs) for these instructions are accessed with the timer numbers.

When a timer number is used in an operand that requires bit data (e.g., in LD, AND, or OR instructions), the timer number accesses the Completion Flag of the timer. When a timer number is used in an operand that requires word data (e.g., in MOV(021) or CMP(020) instructions), the timer number accesses the PV of the timer. Timer Completion Flags can be used as often as necessary as normally open and normally closed conditions and the values of timer PVs can be read as normal word data.

Timer Completion Flags can be force-set and force-reset.

Timer PVs cannot be force-set or force-reset, although the PVs can be refreshed indirectly by force-setting/resetting the Completion Flag.

There are no restrictions in the order of using timer numbers or in the number of NC or NO conditions that can be programmed. Timer PVs can be read as word data and used in programming.

**Note** It is not recommended to use the same timer number in two timer instructions because the timers will not operate correctly if they are timing simultaneously. (If two or more timer instructions use the same timer number, an error will be generated during the program check, but the timers will operate as long as the instructions are not executed in the same cycle.)

The following table shows when timer PVs and Completion Flags will be reset.

Instruction	Mode change between PROGRAM and RUN/MONITOR	FQM1 startup	Operation in jumps (JMP-JME) or tasks on standby	Operation in interlocks (IL-ILC)
TIMER: TIM	PV → 0	PV → 0	PVs refreshed in operating timers	PV → SV (Reset to SV.) Flag → OFF
HIGH-SPEED TIMER: TIMH(015)	Flag → OFF	Flag → OFF		
ONE-MS TIMER: TMHH(540)				

**Note** The present value of TIM, TIMH(015), and TMHH(540) timers programmed will be updated even when jumped between JMP and JME instructions.

## Counter Area

The 256 counter numbers (C0000 to C0255) are shared by the CNT and CNTR(012) instructions. Counter Completion Flags and present values (PVs) for these instructions are accessed with the counter numbers.

When a counter number is used in an operand that requires bit data, the counter number accesses the Completion Flag of the counter. When a counter number is used in an operand that requires word data, the counter number accesses the PV of the counter.

**Note** It is not recommended to use the same counter number in two counter instructions because the counters will not operate correctly if they are counting simultaneously. If two or more counter instructions use the same counter number, an error will be generated during the program check, but the counters will operate as long as the instructions are not executed in the same cycle.

The following table shows when counter PVs and Completion Flags will be reset.

Instruction	Reset	Mode change between PROGRAM and RUN/MONITOR	FQM1 startup	At reset input	Operation in interlocks (IL-ILC)
COUNTER: CNT	PV → 0000	Maintained	Reset	Reset	Maintained
REVERSIBLE COUNTER: CNTR(012)	Flag → OFF				

Counter Completion Flags can be force-set and force-reset.

Counter PVs cannot be force-set or force-reset, although the PVs can be refreshed indirectly by force-setting/resetting the Completion Flag.

There are no restrictions in the order of using counter numbers or in the number of NC or NO conditions that can be programmed. Counter PVs can be read as word data and used in programming.

## Data Memory (DM) Area

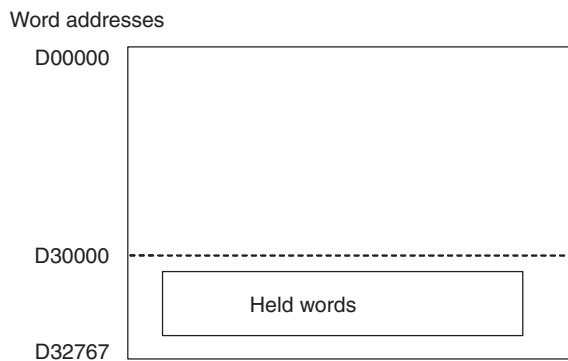

The DM Area contains 32,768 words with addresses ranging from D00000 to D32767. This data area is used for general data storage and manipulation and is accessible only by word.

Data in D00000 to D29999 is cleared to all zeros when the power supply is cycled, but is held when the operating mode is changed from PROGRAM mode to RUN/MONITOR mode or vice-versa.

Data in the D30000 to D32767 is held when the FQM1's power is cycled or the operating mode is changed from PROGRAM mode to RUN/MONITOR mode or vice-versa. (These words are backed up by a super capacitor in a Motion Control Module and by flash memory in the Coordinator Module.)

Bits in the DM Area cannot be accessed directly and cannot be force-set or force-reset.

Words in the DM Area can be indirectly addressed in two ways: binary-mode and BCD-mode.

### Binary-mode Addressing (@D)

When a "@" character is input before a DM address, the content of that DM word is treated as binary and the instruction will operate on the DM word at that binary address. The entire DM Area (D00000 to D32767) can be indirectly addressed with hexadecimal values 0000 to 7FFF.



### BCD-mode Addressing (\*D)

When a "\*" character is input before a DM address, the content of that DM word is treated as BCD and the instruction will operate on the DM word at that BCD address. Only part of the DM Area (D00000 to D09999) can be indirectly addressed with BCD values 0000 to 9999.

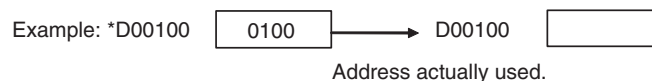

## Condition Flags

These flags include the Error Flag and Carry Flag, which indicate the results of instruction execution. In earlier PLCs, these flags were in the SR Area.

The Condition Flags are specified with labels, such as CY and ER, or with symbols, such as P\_Carry and P\_Instr\_Error, rather than addresses. The status of these flags reflects the results of instruction execution, but the flags are read-only; they cannot be written directly from instructions or CX-Programmer.

**Note** The CX-Programmer treats condition flags as global symbols beginning with P\_.

All Condition Flags are cleared when the program switches tasks, so the status of the ER and AER flags are maintained only in that cycle and in the task in which the error occurred.

The Condition Flags **cannot** be force-set and force-reset except for the Carry Flag, which can be manipulated with the STC(040) and CLC(041) instructions.

### Summary of the Condition Flags

The following table summarizes the functions of the Condition Flags, although the functions of these flags will vary slightly from instruction to instruction. Refer to the description of the instruction for complete details on the operation of the Condition Flags for a particular instruction.

Name	CX-Programmer symbol	Function
Error Flag	P_ER	Turned ON when the operand data in an instruction is incorrect (an instruction processing error) to indicate that an instruction ended because of an error.
Access Error Flag	P_AER	Turned ON when an Illegal Access Error occurs. The Illegal Access Error indicates that an instruction attempted to access an area of memory that should not be accessed.
Carry Flag	P_CY	Turned ON when there is a carry in the result of an arithmetic operation or a "1" is shifted to the Carry Flag by a Data Shift instruction. The Carry Flag is part of the result of some Data Shift and Math instructions.
Greater Than Flag	P_GT	Turned ON when the first operand of a Comparison Instruction is greater than the second or a value exceeds a specified range.
Equals Flag	P_EQ	Turned ON when the two operands of a Comparison Instruction are equal or the result of a calculation is 0.
Less Than Flag	P_LT	Turned ON when the first operand of a Comparison Instruction is less than the second or a value is below a specified range.
Negative Flag	P_N	Turned ON when the most significant bit (sign bit) of a result is ON.
Overflow Flag	P_OF	Turned ON when the result of calculation overflows the capacity of the result word(s).
Underflow Flag	P_UF	Turned ON when the result of calculation underflows the capacity of the result word(s).
Greater Than or Equals Flag	P_GE	Turned ON when the first operand of a Comparison Instruction is greater than or equal to the second.
Not Equal Flag	P_NE	Turned ON when the two operands of a Comparison Instruction are not equal.
Less Than or Equals Flag	P_LE	Turned ON when the first operand of a Comparison Instruction is less than or equal to the second.
Always ON Flag	P_On	Always ON. (Always 1.)
Always OFF Flag	P_Off	Always OFF. (Always 0.)

### Using the Condition Flags

The Condition Flags are shared by all of the instructions, so their status may change often in a single cycle. Be sure to read the Condition Flags immediately after the execution of instruction, preferably in a branch from the same input condition.

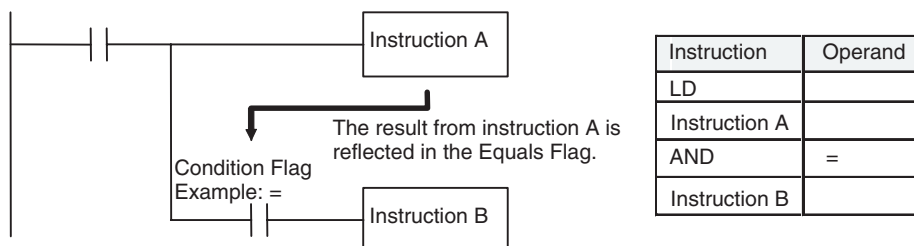

- Note**
- (1) Since the Condition Flags are shared by all of the instructions, program operation can be changed from its expected course by interruption of a single task. Be sure to consider the effects of Condition Flags when writing the program. Refer to *Condition Flags* on page 279 for details.
  - (2) The Condition Flags are cleared when the program switches tasks, so the status of a Condition Flag cannot be passed to another task.

# Clock Pulses

The Clock Pulses are flags that are turned ON and OFF at regular intervals by the system.

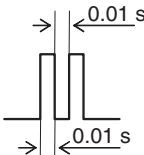
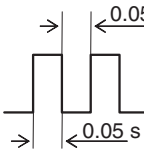
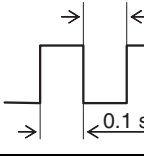
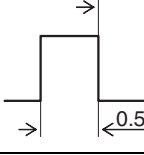
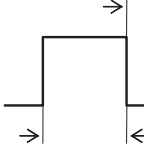
Name	Label	CX-Programmer Symbol	Operation	
0.02 s Clock Pulse	0.02s	P_0_02s		ON for 0.01 s OFF for 0.01 s
0.1 s Clock Pulse	0.1s	P_0_1s		ON for 0.05 s OFF for 0.05 s
0.2 s Clock Pulse	0.2s	P_0_2s		ON for 0.1 s OFF for 0.1 s
1 s Clock Pulse	1s	P_1s		ON for 0.5 s OFF for 0.5 s
1 min Clock Pulse	1min	P_1min		ON for 30 s OFF for 30 s

The Clock Pulses are specified with labels (or symbols) rather than addresses.

**Note** The CX-Programmer treats Clock Pulses as global symbols beginning with P\_.

The Clock Pulses are read-only; they cannot be overwritten from instructions or the CX-Programmer.

The Clock Pulses are cleared at the start of operation.

## Using the Clock Pulses

The following example turns CIO 0001.00 ON and OFF at 0.5 s intervals.

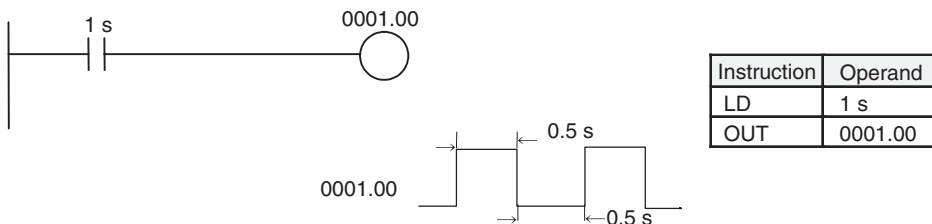

## **Parameter Area**

Unlike the data areas in I/O Memory, which can be used in instruction operands, the Parameter Area can be accessed only from the CX-Programmer. The Parameter Area is made up of the following parts.

- The System Setup
- The Routing Tables

## **System Setup**

The user can customize the basic specifications of the Coordinator Module and Motion Control Modules with the settings in the System Setups. The System Setups contain settings such as the serial port communications settings and constant cycle time setting.

# Appendix C

## System Setup, Auxiliary Area Allocations, and Built-in I/O Allocations

### Overview of System Setups

A System Setup contains software settings that the user can change to customize FQM1 operation. Module functions are set using its System Setup.

The Coordinator Module and Motion Control Modules all have System Setups, which are set from the CX-Programmer to customize operation for the following types of applications.

Cases when settings must be changed	Setting(s) to be changed
<ul style="list-style-type: none"> <li>• When programming the FQM1 for the first time and the Motion Control Modules are being programmed before the Coordinator Module.</li> <li>• When editing or debugging the program in a specific Motion Control Module.</li> </ul>	Sync Mode
<ul style="list-style-type: none"> <li>• When you want the FQM1 to go into RUN mode or MONITOR mode and start operating immediately after startup.</li> <li>• When you want the operating mode to be other than RUN mode when the power is turned ON.</li> </ul>	Startup Mode
When the peripheral port will not be used with the CX-Programmer (peripheral bus) communications speed auto-detection and will not be used with the default Host Link communications settings, such as 9,600 bps.	Peripheral Port Settings
When the RS-232C port will not be used with the CX-Programmer (peripheral bus) communications speed auto-detection and will not be used with the default Host Link communications settings, such as 9,600 bps.	Host Link Port Settings
When you want to communicate with a PT via an NT Link.	Peripheral Port Settings or Host Link Port Settings
You want a constant (minimum) cycle time setting to create a consistent I/O refresh cycle or cycle time.	Cycle Time
You want to set a maximum cycle time other than 50 ms (1 ms to 100 ms).	Watch Cycle Time
You want to extend peripheral servicing time because peripheral services are being executed over several cycles, delaying completion of servicing (want to set a specific time rather than a percent of the cycle time).	Set Time to All Events

The addresses given for the settings in the System Setup are not required for actually making the settings. Use the menus of the CX-Programmer Ver. 5.0□.

### System Setup in the Coordinator Module

#### Sync Settings between Modules (CX-Programmer: Module Settings Tab Page)

##### Allow Writing to User Memory

Address		Settings	Function	Related flags and words	When setting is read
Word	Bits				
+304	00	0: Writing enabled 1: Writing disabled Default: Writing enabled	Sets and releases write-protection for the user memory and System Setup.	---	When disabling: At power ON or at start of operation When enabling: When changed

##### Prohibit System Interrupt of the Sync Mode

Address		Settings	Function	Related flags and words	When setting is read
Word	Bits				
+304	08	0: Not prohibited 1: Prohibited Default: Not prohibited	Sets and releases prohibition of system interrupts during program execution. Set to 1: Prohibit coordinating (matching) the operation start timings among Modules in Sync Mode.	---	At start of operation

**Sync Cycle Time**

Address		Settings	Function	Related flags and words	When setting is read
Word	Bits				
+319	00 to 14	0000 hex: Default (Coordinator Module cycle time) 0001 to 0064 hex: 0.1 to 10.0 ms (unit: 0.1 ms) Default: Coordinator Module cycle time	Sets the cycle time for the Coordinator Module when high-speed synced operation is to be used only between Motion Control Modules.	A404.06 (Sync Cycle Time Too Long Flag)	At power ON

**Sync Mode**

Address		Settings	Function	Related flags and words	When setting is read
Word	Bits				
+319	15	0: Sync mode 1: Async mode Default: Sync mode	Sets either Sync Mode or Async Mode. Sync Mode is used to sync operation between the Coordinator Module and Motion Control Modules.  Async Mode is convenient for debugging Motion Control Modules even if Sync Mode is to be used for actual operation.	---	At power ON

**Startup Mode Setting (CX-Programmer: Startup Tab Page)****Startup Mode**

Address		Settings	Function	Related flags and words	When setting is read
Word	Bits				
+81	00 to 11	00 hex: PROGRAM mode 01 hex: MONITOR mode 02 hex: RUN mode	Sets the mode in which the Coordinator Module will start. The mode set here can also be enabled and disabled. If this setting is disabled, the Coordinator Module will start in RUN mode.	---	At power ON
	15	00: Setting disabled 01: Setting enabled Default: Setting disabled			

**Cycle Time Settings (CX-Programmer: Timer/Peripheral Service)****Cycle Time**

Address		Settings	Function	Related flags and words	When setting is read
Word	Bits				
+307	00 to 15	0001 to 03E8 hex: 0.1 to 100.0 ms (unit: 0.1 ms) Default: 0000 hex (variable cycle time)	Set to 0001 to 03E8 hex to specify a constant (minimum) cycle time. If the cycle time is less than this setting, it will be extended until this time passes. Leave this setting at 0000 for a variable cycle time.	A404.05 (Constant Cycle Time Exceeded Flag)	At start of operation (cannot be changed during operation)

**Watch Cycle Time**

Address		Settings	Function	Related flags and words	When setting is read
Word	Bits				
+308	00 to 15	0001 to 0064 hex: 1 to 100 ms (unit: 0.1 ms) Default: 0000 hex (50 ms)	Change this setting only when you want to change the default maximum cycle time. The Cycle Time Too Long Flag (A401.08) will be turned ON if the actual cycle time exceeds this setting.	A208 to A209 (Present Cycle Time)	At start of operation (cannot be changed during operation)



**Peripheral Port Settings (CX-Programmer: Peripheral Port Tab Page)****Communications Settings**

Address		Settings					Function	Related flags and words	When setting is read		
Word	Bits	Setting	Data length	Start bits	Stop bits	Parity					
+144	00 to 07	00 hex:	7	1	2	Even	Sets the communications conditions for the peripheral port.	A412.15 (Peripheral Port Settings Changing Flag)	At next cycle (Also can be changed with STUP (237).)		
		01 hex:	7	1	2	Odd					
		02 hex:	7	1	2	None					
		04 hex:	7	1	1	Even					
		05 hex:	7	1	1	Odd					
		06 hex:	7	1	1	None					
		08 hex:	8	1	2	Even					
		09 hex:	8	1	2	Odd					
		0A hex:	8	1	2	None					
		0C hex:	8	1	1	Even					
		0D hex:	8	1	1	Odd					
		0E hex:	8	1	1	None					
		Default: 00									

**Peripheral Port Settings for Host Link****Standard/Custom Setting**

Address		Settings	Function	Related flags and words	When setting is read
Word	Bits				
+144	15	0: Standard 1: Custom Default: 0	The standard settings are for 1 start bit, 7-bit data, even parity, 2 stop bits, and 9,600 baud.	A412.15 (Peripheral Port Settings Changing Flag)	At next cycle (Also can be changed with STUP (237).)

**Serial Communications Mode**

Address		Settings	Function	Related flags and words	When setting is read
Word	Bits				
+144	08 to 11	00 hex: Host Link Default: 00 hex	This setting determines whether the peripheral port will operate in Host Link mode or another serial communications mode. Set 00 for Host Link Mode.	A412.15 (Peripheral Port Settings Changing Flag)	At next cycle (Also can be changed with STUP (237).)

**Baud Rate**

Address		Settings	Function	Related flags and words	When setting is read
Word	Bits				
+145	00 to 07	00 hex: 9,600 01 hex: 300 02 hex: 600 03 hex: 1,200 04 hex: 2,400 05 hex: 4,800 06 hex: 9,600 07 hex: 19,200 08 hex: 38,400 09 hex: 57,600 Unit: bit/s Default: 00 hex	This setting is valid when the peripheral port is set for the Host Link Serial Communications Mode. Set the Standard/Custom setting to 1 to enable this setting.	A412.15 (Peripheral Port Settings Changing Flag)	At next cycle (Also can be changed with STUP (237).)

**Host Link Unit Number**

Address		Settings	Function	Related flags and words	When setting is read
Word	Bits				
+147	00 to 07	00 to 1F hex: Unit number 0 to 31 Default: 00 hex	This setting determines the Coordinator Module's unit number when it is connected in a 1-to-N (N=2 to 32) Host Link.	A412.15 (Peripheral Port Settings Changing Flag)	At next cycle (Also can be changed with STUP (237).)

**Peripheral Port Settings for NT Link****Serial Communications Mode**

Address		Settings	Function	Related flags and words	When setting is read
Word	Bits				
+144	08 to 11	02 hex: NT Link Default: 0 hex	This setting determines whether the peripheral port will operate in NT Link mode or another serial communications mode. Set 02 for NT Link Mode. <b>Note</b> Communications will not be possible with PTs set for 1:1 NT Links.	A412.15 (Peripheral Port Settings Changing Flag)	At next cycle (Also can be changed with STUP (237).)

**Baud Rate**

Address		Settings	Function	Related flags and words	When setting is read
Word	Bits				
+145	00 to 07	08 hex: Standard NT Link Default: 00 hex	Only the standard setting of 38,400 can be used for the NT Link Serial Communications Mode.	A412.15 (Peripheral Port Settings Changing Flag)	At next cycle (Also can be changed with STUP (237).)

**Maximum Unit Number for NT Link (NT Link Max.)**

Address		Settings	Function	Related flags and words	When setting is read
Word	Bits				
+150	00 to 03	0 to 7 hex Default: 0 hex	This setting determines the highest unit number of PT that can be connected to the FQM1.	A412.15 (Peripheral Port Settings Changing Flag)	At next cycle (Also can be changed with STUP (237).)

**Peripheral Port Settings for Peripheral Bus (ToolBus)****Standard/Customer Setting**

Address		Settings	Function	Related flags and words	When setting is read
Word	Bits				
+144	15	0: Standard 1: Custom Default: 0	The standard setting is for 9,600 baud.	A412.15 (Peripheral Port Settings Changing Flag)	At next cycle (Also can be changed with STUP (237).)

**Serial Communications Mode**

Address		Settings	Function	Related flags and words	When setting is read
Word	Bits				
+144	08 to 11	04 hex: Peripheral bus Default: 0 hex	This setting determines whether the peripheral port will operate in Peripheral Bus Mode or another serial communications mode. Set 04 for Peripheral Bus Mode. Peripheral Bus Mode is used to communicate with the CX-Programmer.	A412.15 (Peripheral Port Settings Changing Flag)	At next cycle (Also can be changed with STUP (237).)

**Baud Rate**

Address		Settings	Function	Related flags and words	When setting is read
Word	Bits				
+145	00 to 07	00 hex: 9,600 06 hex: 9,600 07 hex: 19,200 08 hex: 38,400 09 hex: 57,600 Unit: bit/s Default: 00 hex	Only settings 00 hex and 06 to 09 hex can be used in peripheral bus mode.	A412.15 (Peripheral Port Settings Changing Flag)	At next cycle (Also can be changed with STUP (237).)

**RS-232C Port Settings (CX-Programmer: Host Port Tab Page)****RS-232C Port Settings for Host Link****Serial Communications Mode**

Address		Settings	Function	Related flags and words	When setting is read
Word	Bits				
+160	08 to 11	00 hex: Host Link 05 hex: Host Link Default: 00 hex	This setting determines whether the RS-232C port will operate in Host Link mode or another serial communications mode. Specify either 00 or 05 for Host Link Mode.	A410.15 (RS-232C Port Settings Changing Flag)	At next cycle (Also can be changed with STUP (237).)

**Format**

Address		Settings	Function	Related flags and words	When setting is read
Word	Bits				
+160	15	0: Default format 1: Custom Default: 00 hex	The standard settings are for 1 start bit, 7-bit data, even parity, 2 stop bits, and 9,600 baud.	A410.15 (RS-232C Port Settings Changing Flag)	At next cycle (Also can be changed with STUP (237).)
	03	0: 7-bit 1: 8-bit Default: 0	Sets the data length.		
	02	0: 2 bits 1: 1 bit Default: 0	Sets the number of stop bits.		
	00 and 01	00: Even 01: Odd 10: None Default: 00 hex	Sets the parity.		

**Baud Rate**

Address		Settings	Function	Related flags and words	When setting is read
Word	Bits				
+161	00 to 07	00 hex: 9,600 01 hex: 300 02 hex: 600 03 hex: 1,200 04 hex: 2,400 05 hex: 4,800 06 hex: 9,600 07 hex: 19,200 08 hex: 38,400 09 hex: 57,600 Unit: bit/s Default: 00 hex	Sets the Host Link baud rate. Set the Standard/Custom setting to 1 to enable this setting.	A410.15 (RS-232C Port Settings Changing Flag)	At next cycle (Also can be changed with STUP (237).)

**Host Link Unit Number**

Address		Settings	Function	Related flags and words	When setting is read
Word	Bits				
+163	00 to 07	00 to 1F hex: 0 to 31 Default: 00 hex	This setting determines the Coordinator Module's unit number when it is connected in a 1-to-N (N=2 to 32) Host Link.	A410.15 (RS-232C Port Settings Changing Flag)	At next cycle (Also can be changed with STUP (237).)

**RS-232C Port Settings for NT Link****Serial Communications Mode**

Address		Settings	Function	Related flags and words	When setting is read
Word	Bits				
+160	08 to 11	02 hex: NT Link Default: 00 hex	This setting determines whether the RS-232C port will operate in NT Link mode or another serial communications mode. Set 02 for NT Link Mode. <b>Note</b> Communications will not be possible with PTs set for 1:1 NT Links.	A410.15 (RS-232C Port Settings Changing Flag)	At next cycle (Also can be changed with STUP (237).)

**Baud Rate**

Address		Settings	Function	Related flags and words	When setting is read
Word	Bits				
+161	00 to 07	08 hex: Standard setting Default: 00 hex	Only the standard setting of 38,400 can be used for the NT Link Serial Communications Mode.	A410.15 (RS-232C Port Settings Changing Flag)	At next cycle (Also can be changed with STUP (237).)

**Maximum Unit Number for NT Link (NT Link Max.)**

Address		Settings	Function	Related flags and words	When setting is read
Word	Bits				
+166	00 to 03	0 to 7 hex Default: 00 hex	This setting determines the highest unit number of PT that can be connected to the FQM1.	A410.15 (RS-232C Port Settings Changing Flag)	At next cycle (Also can be changed with STUP (237).)

**RS-232C Port Settings for Peripheral Bus (ToolBus)****Standard/Custom Setting**

Address		Settings	Function	Related flags and words	When setting is read
Word	Bits				
+160	15	0: Standard 1: Custom Default: 0	The standard setting is for 9,600 baud.	A410.15 (RS-232C Port Settings Changing Flag)	At next cycle (Also can be changed with STUP (237).)

**Serial Communications Mode**

Address		Settings	Function	Related flags and words	When setting is read
Word	Bits				
+160	08 to 11	04 hex: Peripheral bus Default: 0 hex	This setting determines whether the RS-232C port will operate in Peripheral Bus Mode or another serial communications mode. Set 04 for Peripheral Bus Mode. Peripheral Bus Mode is used to communicate with the CX-Programmer.	A410.15 (RS-232C Port Settings Changing Flag)	At next cycle (Also can be changed with STUP (237).)

**Baud Rate**

Address		Settings	Function	Related flags and words	When setting is read
Word	Bits				
+161	00 to 07	00 hex: 9,600 06 hex: 9,600 07 hex: 19,200 08 hex: 38,400 09 hex: 57,600 Unit: bit/s Default: 00 hex	Only settings 00 hex and 06 to 09 hex can be used in peripheral bus mode.	A410.15 (RS-232C Port Settings Changing Flag)	At next cycle (Also can be changed with STUP (237).)

**RS-232 Port Settings for No-protocol Communications (RS-232C)****Serial Communications Mode**

Address		Settings	Function	Related flags and words	When setting is read
Word	Bits				
+160	08 to 11	03 hex: No-protocol Default: 00 hex	This setting determines whether the RS-232C port will operate in No-protocol mode or another serial communications mode. Set 03 for No-protocol Mode.	A410.15 (RS-232C Port Settings Changing Flag)	At next cycle (Also can be changed with STUP (237).)

**Data Format**

Address		Settings	Function	Related flags and words	When setting is read
Word	Bits				
+160	15	0: Default format 1: Custom Default: 00 hex	The standard settings are for 1 start bit, 7-bit data, even parity, 2 stop bits, and 9,600 baud.	A410.15 (RS-232C Port Settings Changing Flag)	At next cycle (Also can be changed with STUP (237).)
	03	0: 7-bit 1: 8-bit Default: 0	Sets the data length.		
	02	0: 2 bits 1: 1 bit Default: 0	Sets the number of stop bits.		
	00 and 01	00: Even 01: Odd 10: None Default: 00 hex	Sets the parity.		

**Baud Rate**

Address		Settings	Function	Related flags and words	When setting is read
Word	Bits				
+161	00 to 07	00 hex: 9,600 01 hex: 300 02 hex: 600 03 hex: 1,200 04 hex: 2,400 05 hex: 4,800 06 hex: 9,600 07 hex: 19,200 08 hex: 38,400 09 hex: 57,600 Unit: bit/s Default: 00 hex	This setting is valid when the RS-232C port is set for the No-protocol Serial Communications Mode. Set the Data Format setting to 1 to enable this setting.	A410.15 (RS-232C Port Settings Changing Flag)	At next cycle (Also can be changed with STUP (237).)

**Send Delay**

Address		Settings	Function	Related flags and words	When setting is read
Word	Bits				
+162	00 to 15	Send delay time, 0 to 99,990 ms (0000 to 270F hex, unit: 10 ms) Default: 0000 hex	When TXD(236) is executed, data will be sent from the RS-232C port after the delay time set here.	A410.15 (RS-232C Port Settings Changing Flag)	At next cycle (Also can be changed with STUP (237).)

**Start Code and End Code**

Address		Settings	Function	Related flags and words	When setting is read
Word	Bits				
+164	00 to 07	00 to FF hex Default: 00 hex	The frame format for no-protocol communications data (messages) can be specified.	A410.15 (RS-232C Port Settings Changing Flag)	At next cycle (Also can be changed with STUP (237).)
		08 to 15			
+165	12	0: Don't add start code 1: Add start code Default: 0	Specifies whether the frame format for no-protocol communications is specified.	A410.15 (RS-232C Port Settings Changing Flag)	At next cycle (Also can be changed with STUP (237).)
		08 and 09			

**Number of Received Bytes**

Address		Settings	Function	Related flags and words	When setting is read
Word	Bits				
+165	00 to 07	00 hex: 256 bytes 01 to FF hex: 1 to 255 Default: 00 hex	Specifies the data length to send and receive for no-protocol communications. The start code and end code are not included in the data length.  This setting is valid only when bits 08 and 09 of +165 are set to 00.  The default setting for each TXD(236)/RXD(235) instruction is 256 bytes. This setting can be set to 01 to FF to set 255 bytes or less.	A410.15 (RS-232C Port Settings Changing Flag)	At next cycle (Also can be changed with STUP (237).)

**RS-232C Port Settings for PLC Link (PC Link (Slave))****Serial Communications Mode**

Address		Settings	Function	Related flags and words	When setting is read
Word	Bits				
+160	08 to 11	07 hex: Serial PLC Link Slave (Polled Unit) Default: 00 hex	This setting determines whether the RS-232C port will operate in Serial PLC Link Slave mode or another serial communications mode. Set 07 for Serial PLC Link Slave Mode.	A410.15 (RS-232C Port Settings Changing Flag)	At next cycle (Also can be changed with STUP (237).)

**Baud Rate**

Address		Settings	Function	Related flags and words	When setting is read
Word	Bits				
+161	00 to 07	00 hex: Standard setting Default: 00 hex	Only the standard setting of 38,400 can be used for the Serial PLC Link Slave Serial Communications Mode.	A410.15 (RS-232C Port Settings Changing Flag)	At next cycle (Also can be changed with STUP (237).)

**PLC Link Unit No. (PC Link Unit Number)**

Address		Settings	Function	Related flags and words	When setting is read
Word	Bits				
+167	00 to 03	0 to 7 hex Default: 0 hex	Sets the unit number of the FQM1 as a Serial PLC Link Slave.	A410.15 (RS-232C Port Settings Changing Flag)	At next cycle (Also can be changed with STUP (237).)

**RS-422A Port Settings (CX-Programmer: Drive Tab Page)****RS-422A Port Settings for Serial Gateway****Standard/Custom Setting**

Address		Settings	Function	Related flags and words	When setting is read
Word	Bits				
+360	15	0: Standard settings Default: 0	The standard settings are for 1 start bit, 7-bit data, even parity, 2 stop bits, and 9,600 baud.	A414.15 (RS-422A Port Settings Changing Flag)	---

**Serial Communications Mode**

Address		Settings	Function	Related flags and words	When setting is read
Word	Bits				
+360	08 to 11	00 or 09 hex: Serial Gateway Default: 00 hex	This setting determines whether the RS-422A port will operate in Serial Gateway mode or another serial communications mode. Set 00 or 09 for Serial Gateway Mode.	A414.15 (RS-422A Port Settings Changing Flag)	At next cycle (Also can be changed with STUP (237).)

**RS-422A Response Timeout Time (RS422 Response Timeout of Command)**

Address		Settings	Function	Related flags and words	When setting is read
Word	Bits				
+367	00 to 15	0001 to 00FF hex: 0.1 to 25.5 s Default: 0000 hex (5 s)	Sets the timeout time for a response from the Servo Driver.	A414.15 (RS-422A Port Settings Changing Flag)	At next cycle (Also can be changed with STUP (237).)

**RS-422A Port Settings for No-protocol Communications (Non-procedural)****Serial Communications Mode**

Address		Settings	Function	Related flags and words	When setting is read
Word	Bits				
+360	08 to 11	03 hex: No-protocol Default: 00 hex	This setting determines whether the RS-422A port will operate in no-protocol mode or another serial communications mode. Set 03 for No-protocol Mode.	A414.15 (RS-422A Port Settings Changing Flag)	At next cycle (Also can be changed with STUP (237).)

**Send Delay Time**

Address		Settings	Function	Related flags and words	When setting is read
Word	Bits				
+362	00 to 15	Send delay time, 0 to 99,990 ms (0000 to 270F hex, unit: 10 ms) Default: 0000 hex	When TXD(236) is executed, data will be sent from the RS-422A port after the delay time set here.	A414.15 (RS-422A Port Settings Changing Flag)	At next cycle (Also can be changed with STUP (237).)

**Start Code and End Code**

Address		Settings	Function		Related flags and words	When setting is read
Word	Bits					
+364	00 to 07	00 to FF hex Default: 00 hex	The frame format for no-protocol communications data (messages) can be specified.	Specifies the end code. This setting is valid when bits 08 to 09 of +365 are set to 01.	A414.15 (RS-422A Port Settings Changing Flag)	At next cycle (Also can be changed with STUP (237).)
	08 to 15	00 to FF hex Default: 00 hex		Specifies the start code. This setting is valid when bit 12 of +365 is set to 1.		
+365	12	0: Don't add start code 1: Add start code Default: 0	Specifies whether the frame format for no-protocol communications is specified.	Specifies whether to add a start code.		
	08 and 09	00: Don't add end code and use number of received bytes setting 01: Add end code 11: Add CR+LF Default: 00		Specifies whether to add an end code.		

**Number of Received Bytes**

Address		Settings	Function		Related flags and words	When setting is read
Word	Bits					
+365	00 to 07	00 hex: 256 bytes 01 to FF hex: 1 to 255 Default: 00 hex	Specifies the data length to send and receive for no-protocol communications. The start code and end code are not included in the data length. This setting is valid only when bits 08 and 09 of +365 are set to 00. The default setting for each TXD(236)/RXD(235) instruction is 256 bytes. This setting can be set to 01 to FF to set 255 bytes or less.	A414.15 (RS-422A Port Settings Changing Flag)	At next cycle (Also can be changed with STUP (237).)	

**Peripheral Service Time Settings (CX-Programmer: Timer/Peripheral Tab Page)****Fixed Service Time Enable Setting (Set Time to All Events)**

Address		Settings	Function		Related flags and words	When setting is read
Word	Bits					
+218	15	0: Default (6.25% of cycle time) 1: Custom Default: 0	Sets the default service time or enables setting of a custom service time.	---	At start of operation (cannot be changed during operation)	

**Peripheral Service Time**

Address		Settings	Function		Related flags and words	When setting is read
Word	Bits					
+218	00 to 07	00 to FF hex: 0.0 to 25.5 ms (unit: 0.1 ms) Default: 00 hex	Sets the time to allocate to peripheral servicing. Bit 15 of +218 must be set to 1 to enable this setting.	---	At start of operation (cannot be changed during operation)	



## System Setup in Motion Control Modules

### Settings Used by All Motion Control Modules

#### CX-Programmer: Module Settings Tab Page

Address	Bits	Function	Remarks	When setting is read
+304	00	Allow writing to user memory (user memory protection)	0 hex: Writing enabled 1 hex: Writing disabled <b>Note</b> Set this bit to 1 to disable writing the following areas from the CX-Programmer: user program and System Setup	When disabling: At power ON or at start of operation When enabling: When changed
	08	Prohibit system interruption of the sync mode	0 hex: Allow interrupts 1 hex: Prohibit interrupts Set this bit to 1 to prohibit system interrupts during program execution and I/O memory refreshing to maintain synced operation between Modules in Sync Mode.	At power ON
	12	Detect cycle time over warning (detection of cycle times longer than 10 ms)	0 hex: Detect long cycles 1 hex: Do not detect long cycles <b>Note</b> CIO 0105.09 will turn ON if this bit is set to 0 and the cycle time exceeds 10 ms.	At start of operation
+305	00 to 03	Interrupt Input Settings, Input 0 (CIO 0000.00) function	0 hex: Normal 1 hex: Interrupt input (at rising edge) 2 hex: Interrupt input (at falling edge) 3 hex: Interrupt input (at both edges) <b>Note</b> Interrupt input settings of 1 to 3 hex apply to input interrupt mode and counter mode.	At power ON
	04 to 07	Interrupt Input Settings, Input 1 (CIO 0000.01) function		
	08 to 11	Interrupt Input Settings, Input 2 (CIO 0000.02) function		
	12 to 15	Interrupt Input Settings, Input 3 (CIO 0000.03) function		
+306	00 to 07	Select Synchronous Data	Upper 2 words (+0 and +1) Lower 2 words (+2 and +3) 00 hex: Normal (via Ladder) 01 hex: High-speed counter PV (Counter 1 values) 02 hex: High-speed counter PV (Counter 2 values) 03 hex: Pulse output 1 PV 04 hex: Pulse output 2 PV 05 hex: Analog input 06 hex: Reserved 07 hex: Analog output 1 value 08 hex: Analog output 2 value 09 hex: Built-in input value (Inner I/O input) 5A hex: No data	
	08 to 15			

#### CX-Programmer: Cycle Time Tab Page

Address	Bits	Function	Remarks	When setting is read
+307	00 to 15	Cycle time	0000 hex: Variable cycle time 0001 to 03E8 hex: Constant (minimum) cycle time of 0.1 to 100.0 ms (unit: 0.1 ms) If the actual cycle time is less than this setting, it will be extended until this time passes. <b>Note</b> A404.05 will turn ON if the minimum cycle time set here is exceeded.	At start of operation
+308	00 to 15	Watch cycle time	Change this setting only when you want to change the default maximum cycle time. The Cycle Time Too Long Flag (A401.08) will be turned ON if the actual cycle time exceeds this setting.	At start of operation

#### CX-Programmer: Other Tab Page

These settings are reserved for future expansion of Motion Control Module functionality.

## FQM1-MMP21 Motion Control Modules with Pulse I/O

## CX-Programmer: Pulse Input Tab Page

Address	Bits	Function	Remarks	When setting is read
+320	00 to 03	High-speed counter 1 (Counter 1)	Input method 0 hex: Phase differential x1 1 hex: Phase differential x2 2 hex: Phase differential x4 3 hex: Increment/decrement pulse inputs 4 hex: Pulse + direction inputs	At power ON
	04 to 07		Reset method 0 hex: Software reset 1 hex: Phase Z and software reset	
	08 to 11		Counting speed 0 hex: 50 kHz 1 hex: 500 kHz	
	12 to 15		Counter operating mode (Counter operation) 0 hex: Linear counter 1 hex: Circular counter 2 hex: Absolute linear counter (CW-) 3 hex: Absolute circular counter 4 hex: Absolute linear counter (CW+) <b>Note</b> When setting any mode except for a linear counter (0 hex), be sure to set the Circular Maximum Count/Absolute Encoder Resolution.	
+321	00 to 03	Counter data to monitor (Counter data display) 0 hex: Do not monitor (Non-monitor) 1 hex: Counter PV changes (Counter movements (mode 1)) 2 hex: Frequency (mode 2) <b>Note</b> The frequency (mode 2) can be set only for high-speed counter 1.		
	04 to 15	Reserved		
+322	00 to 15	Sampling time (for mode 1 only)	Sets the sampling time for monitoring counter PV changes (mode 1) 0000: Cycle time 0001 to 270F hex: 1 to 9,999 ms (unit: 1 ms) <b>Note</b> This setting is valid only when the Counter Data Display (bits 00 to 03 of +321) is set to 1 hex (mode 1).	

Address	Bits	Function		Remarks	When setting is read
+323	00 to 03	High-speed counter 2 (Counter 2)	Input method	Same as for high-speed counter 1 except that frequency measurement (Counter data to monitor, bit 00 to 03 of +324: 02 hex) cannot be set for high-speed counter 2.	At power ON
	04 to 07		Reset method		
	08 to 11		Counting speed		
	12 to 15		Counter operating mode (Counter operation)		
+324	00 to 03	High-speed counter 2 (Counter 2)	Counter data to monitor (Counter data display)		
	04 to 15		Reserved		
+325	00 to 15	High-speed counter 2 (Counter 2)	Sampling time (for mode 1 only)		
+326 to 327	00 to 15	High-speed counter 1 (Counter 1)	Circular maximum count	Sets the maximum circular counter value. Range: 0000 0001 to FFFF FFFF hex	
			Absolute encoder resolution	0000 0001 to 0000 FFFF hex <b>Note</b> Set this value in pulses/rotation according to the encoder dividing ratio set for the Servo Driver and the input method multiplier set for the Module. Example: If the Servo Driver setting is 1,000 and the Module setting is x4, set FA0 (4,000).	
+328 to 329	00 to 15	High-speed counter 2 (Counter 2)	Circular maximum count	Same as for high-speed counter 1.	
			Absolute encoder resolution		
+330 to 331	00 to 15	High-speed counter 1 (Counter 1)	Absolute offset	8000 0000 to 7FFF FFFF hex	
+332 to 333	00 to 15	High-speed counter 2 (Counter 2)	Absolute offset	8000 0000 to 7FFF FFFF hex	

**CX-Programmer: Pulse Output Tab Page**

Address	Bits	Function		Remarks	When setting is read
+340	00 to 07	Pulse output 1	Operation mode (Refer to 7-6-6 <i>Pulse Output Function Details</i> .)	00 hex: Relative pulse output	At power ON
				01 hex: Absolute pulse output in linear mode	
				02 hex: Absolute pulse output in circular mode (See note.)	
				03 hex: Electronic cam control in linear mode (See note.)	
				04 hex: One-shot pulse output	
	05 hex: Time measurement using pulse counter				
06 hex: Electronic cam control in circular mode (See note.)					
08 to 15	Pulse output 1	Clock	00 hex: 20 MHz	Pulse output frequency: 400 Hz to 1 MHz	
			01 hex: 10 MHz	Pulse output frequency: 200 Hz to 200 kHz	
			02 hex: 5 MHz	Pulse output frequency: 100 Hz to 100 kHz	
			03 hex: 2.5 MHz	Pulse output frequency: 40 Hz to 50 kHz	
			04 hex: 1.25 MHz	Pulse output frequency: 20 Hz to 20 kHz	
+341	00 to 07	Pulse output 2	Operation mode	Same as for pulse output 1.	
	08 to 15		Clock		
+342 to 343	00 to 15	Pulse output 1	Circular maximum count	Sets the maximum circular counter value when the pulse output mode is set to absolute pulse output in circular mode or electronic cam control in circular mode. Range: 0000 0001 to FFFF FFFF hex (See note.)	
+344 to +345	00 to 15	Pulse output 2	Circular maximum count	Same as for pulse output 1.	

**Note** Always set the Circular Maximum Count when setting any of the circular operation modes.

## FQM1-MMA21 Motion Control Modules with Analog I/O

### CX-Programmer: Pulse Input Tab Page

Address	Bits	Function	Remarks	When setting is read	
+320	00 to 03	High-speed counter 1 (Counter 1)	Input method	0 hex: Phase differential x1 1 hex: Phase differential x2 2 hex: Phase differential x4 3 hex: Increment/decrement pulse inputs 4 hex: Pulse + direction inputs	At power ON
	04 to 07		Reset method	0 hex: Software reset 1 hex: Phase Z and software reset	
	08 to 11		Counting speed	0 hex: 50 kHz 1 hex: 500 kHz	
	12 to 15		Counter operating mode (Counter operation)	0 hex: Linear counter 1 hex: Circular counter 2 hex: Absolute linear counter (CW-) 3 hex: Absolute circular counter 4 hex: Absolute linear counter (CW+)	
+321	00 to 03	Counter data to monitor (Counter data display)	Counter data to monitor (Counter data display)	0 hex: Do not monitor (Non-monitor) 1 hex: Counter PV changes (Counter movements (mode 1)) 2 hex: Frequency (mode 2) <b>Note</b> The frequency (mode 2) can be set only for high-speed counter 1.	
	04 to 15		Reserved		
+322	00 to 15	Sampling time (for mode 1 only)	Sets the sampling time for monitoring counter PV changes (mode 1) 0000: Cycle time 0001 to 270F hex: 1 to 9,999 ms (unit: 1 ms) <b>Note</b> This setting is valid only when the Counter Data Display (bits 00 to 03 of +321) is set to 1 hex (mode 1).		
+323	00 to 03	High-speed counter 2 (Counter 2)	Input method	Same as for high-speed counter 1 except that frequency measurement (Counter data to monitor, bit 00 to 03 of +324: 02 hex) cannot be set for high-speed counter 2.	
	04 to 07		Reset method		
	08 to 11		Counting speed		
	12 to 15		Counter operating mode (Counter operation)		
+324	00 to 03	Counter data to monitor (Counter data display)	Counter data to monitor (Counter data display)		
	04 to 15		Reserved		
+325	00 to 15	Sampling time (for mode 1 only)			
+326 to 327	00 to 15	High-speed counter 1 (Counter 1)	Circular maximum count	Sets the maximum circular counter value. Range: 0000 0001 to FFFF FFFF hex	
			Absolute encoder resolution	0000 0001 to 0000 FFFF hex <b>Note</b> Set this value in pulses/rotation according to the encoder dividing ratio set for the Servo Driver and the input method multiplier set for the Module. Example: If the Servo Driver setting is 1,000 and the Module setting is x4, set FA0 (4,000).	
+328 to 329	00 to 15	High-speed counter 2 (Counter 2)	Circular maximum count	Same as for high-speed counter 1.	
			Absolute encoder resolution		

Address	Bits	Function		Remarks	When setting is read
+330 to 331	00 to 15	High-speed counter 1 (Counter 1)	Absolute offset	8000 0000 to 7FFF FFFF hex Application origin when using an absolute encoder.	Immediately
+332 to 333	00 to 15	High-speed counter 2 (Counter 2)	Absolute offset	Same as high-speed counter 1.	

### CX-Programmer: Analog Input/Output Tab Page

Address	Bits	Function		Remarks	When setting is read
+350	00 to 03	Analog I/O	Input method	0 hex: END refresh 1 hex: Immediate refresh (using PRV(881) instruction)	At power ON
	04 to 07		Output method	0 hex: END refresh (Analog value output to A560 and A561 after executing END(001).) 1 hex: Immediate refresh (using instructions) (Analog value output when SPED(885) or ACC(888) is executed.) (A560 and A561 are used for monitoring.)	
+351	00 to 07	Analog input	Input range	00 hex: -10 to 10 V 01 hex: 0 to 10 V 02 hex: 1 to 5 V (4 to 20 mA) 03 hex: 0 to 5 V	At power ON
+353	00 to 07	Analog output 1	Output range	00 hex: -10 to 10 V 01 hex: 0 to 10 V 02 hex: 1 to 5 V 03 hex: 0 to 5 V 5A hex: Output disabled (Can be used to shorten I/O refresh time.) (See note.)	At power ON
	08 to 11		Output stop function	0 hex: Clear 1 hex: Hold 2 hex: Maximum value	
+354	00 to 07	Analog output 2	Output range	Same as for analog output 1.	
	08 to 15		Output stop function		

**Note** Analog outputs that are not being used can be disabled to decrease the cycle time.

## Details on System Setup Settings

### Startup Mode

This setting determines the operating mode that will be used when the power supply to the Coordinator Module is turned ON.

System Setup mode setting disabled	RUN mode
System Setup mode setting enabled	Program: PROGRAM mode Monitor: MONITOR mode Run: RUN mode

**Note** The Coordinator Module will start in RUN mode unless the Startup Mode setting in the System Setup is enabled.

### Peripheral Port Settings

The standard settings are for Host Link Mode, 1 start bit, 7-bit data, even parity, 2 stop bits, and 9,600 baud. Change the System Setup if any other settings are required.

### RS-232C Port Settings (Host Link Port)

The standard settings are for Host Link Mode, 1 start bit, 7-bit data, even parity, 2 stop bits, and 9,600 baud. Change the System Setup if any other settings are required. If no-protocol communications are to be used, be sure to change the frame format.

**Note** The RS-232C port settings can also be changed with the STUP (237) instruction. The RS-232C Port Settings Changing Flag (A410.15) will remain ON from the time STUP (237) is executed until the settings have actually been changed.

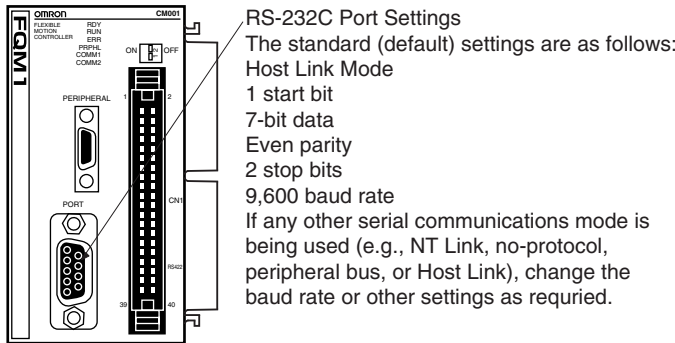

**Note** The following data is set for no-protocol mode.

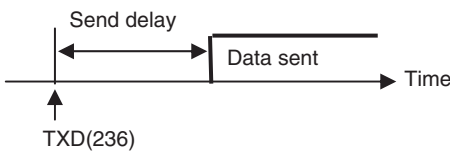

**Messages Sent and Received with No-protocol Mode**

		End code		
		No	Yes	CR+LF
Start code	No	Data	Data ED	Data CR+LF
	Yes	ST Data	ST Data ED	ST Data CR+LF
Received bytes		Data: 1 to 256 bytes		

**Constant Cycle Time**

Set the cycle time to a non-zero value, e.g., to create a consistent motor control cycle. This setting is effective only when the actual cycle time is shorter than the constant cycle time setting. If the actual cycle time is longer than the constant cycle time setting, the actual cycle time will remain unchanged.

**Note** The constant cycle time setting cannot be changed while the Module is in RUN or MONITOR mode.

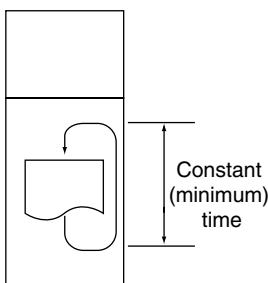

**Watch Cycle Time**

If the cycle time exceeds the watch (maximum) cycle time setting, the Cycle Time Too Long Flag (A401.08) will be turned ON and FQM1 operation will be stopped. This setting must be changed if the normal cycle time exceeds the default watch cycle time setting of 50 ms.

**Note** The watch cycle time setting cannot be changed while the Module is in RUN or MONITOR mode.

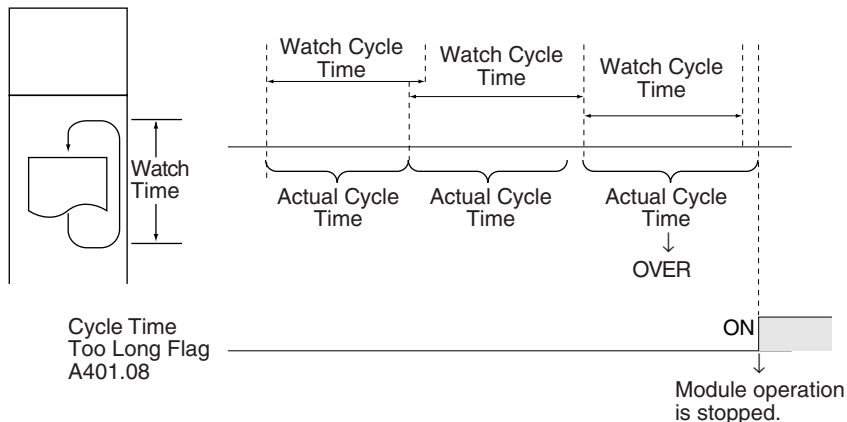

**Note** The default value for the watch cycle time is 50 ms.

### Fixed Peripheral Servicing Time

This setting determines whether the peripheral servicing for the following processes is performed with the default settings (6.25% of the cycle time) or all together in a fixed servicing time.

- Exchange data with Modules when necessary
- Exchange data with peripheral port
- Exchange data with serial communications ports

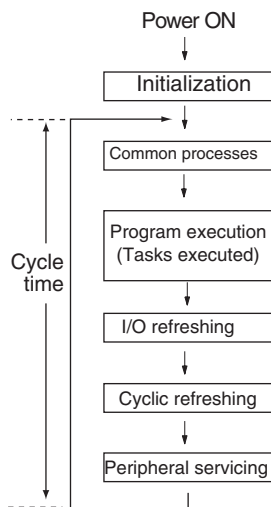

The following table shows a breakdown of the peripheral servicing time.

Peripheral servicing time	Default value	Setting range
Event service time for Motion Control Modules	6.25% of the previous cycle's cycle time	Uniform servicing time in ms: 0.0 to 25.5 ms (unit: 0.1 ms)
Event service time for peripheral port	Same as above.	
Event service time for RS-232C port	Same as above.	
Event service time for RS-422A port	Same as above.	

**Note** A default value of 100  $\mu$ s is allocated in Motion Control Modules for event servicing with the Coordinator Module

The default value for each servicing process is 6.25% of the last cycle's cycle time. In general, it is recommended that the default value be used. Set a uniform servicing time only when peripheral servicing is being delayed because each service process is being spread over several cycles.

- Note**
- (1) When the peripheral servicing time is set to a time longer than the default value, the cycle time will also be longer.
  - (2) The fixed peripheral servicing time setting cannot be changed while the Module is in RUN mode or MONITOR mode.



## Auxiliary Area Allocations by Function

The following tables list the words and bits allocated in the Auxiliary Area by function. These tables provide only an overview of the functionality. Refer to *Appendix D Auxiliary Area Allocations* for details or a list of allocations by address.

### Motion Control Modules

#### Allocations That Are the Same for All Modules

Address	Bits	Name	Function	Controlled by
A202	00	Motion Control Module slot 1	ON if the Motion Control Module is in slot 1.	Module
	01	Motion Control Module slot 2	ON if the Motion Control Module is in slot 2.	
	02	Motion Control Module slot 3	ON if the Motion Control Module is in slot 3.	
	03	Motion Control Module slot 4	ON if the Motion Control Module is in slot 4.	

#### FQM1-MMP21 Motion Control Modules with Pulse I/O

Address	Bits	Name		Function	Controlled by
A600	00 to 15	High-speed Counter 1 PV		Range: 8000 0000 to 7FFF FFFF	Module
A601	00 to 15			<b>Note</b> For a Linear Counter, high-speed counter overflows/underflows are checked when the PV is read (i.e., when Module internal I/O is refreshed).	
A602	00 to 15	High-speed Counter 2 PV			
A603	00 to 15				
A604 to A605	00 to 15	High-speed Counter 1	For following counter modes	PV of absolute number of rotations	Contains the number of rotations data (PV) read from the Encoder when the SEN signal is input to the Servo Driver. 8000 0000 to 7FFF FFFF hex
			<ul style="list-style-type: none"> <li>• Absolute linear (CW-)</li> <li>• Absolute circular</li> <li>• Absolute linear (CW+)</li> </ul>		
A606 to A607	00 to 15	High-speed Counter 2	For following counter modes	Monitor data	<ul style="list-style-type: none"> <li>• When monitoring counter movements (mode 1), contains the absolute value of the amount of change in the PV of the high-speed counter over the specified sampling time as a 8-digit hexadecimal value (0000 0000 to FFFF FFFF hex).</li> <li>• When monitoring the counter frequency (mode 2), contains the frequency of the high-speed counter calculated from the PV of the high-speed counter between 0 and 7A120 hex (0 and 500 kHz).</li> </ul>
			<ul style="list-style-type: none"> <li>• Linear counter</li> <li>• Circular counter</li> </ul>		
A606 to A607	00 to 15	High-speed Counter 2	For following counter modes	PV of absolute number of rotations	Same as for A604 and A605 for high-speed counter 1 except that measuring the high-speed counter frequency is not possible for high-speed counter 2.
			<ul style="list-style-type: none"> <li>• Absolute linear (CW-)</li> <li>• Absolute circular</li> <li>• Absolute linear (CW+)</li> </ul>		
A606 to A607	00 to 15	High-speed Counter 2	For following counter modes	Monitor data	
			<ul style="list-style-type: none"> <li>• Linear counter</li> <li>• Circular counter</li> </ul>		

Address	Bits	Name	Function	Controlled by
A608	00	High-speed counter 1 status	Target Comparison In-progress Flag  <b>OFF:</b> Target value comparison is not being performed for CTBL(882). <b>Note</b> This flag is always OFF for range comparison. <b>ON:</b> Target value comparison is being performed for CTBL(882). <b>Note</b> Target comparison is continued without interruption once it has been started (as opposed to range comparison), so this flag can be used to check whether target comparison is in progress.	Module
	01		PV Overflow/Underflow Flag  <b>OFF:</b> There is no counter overflow or underflow in Linear Counter Mode. This flag will always be OFF in Circular Counter Mode. <b>ON:</b> There is a counter overflow or underflow in Linear Counter Mode. The counter PV will be fixed at the overflow or underflow limit. This flag will be cleared when the High-speed Counter Start Bit is turned OFF.	
	02	Reserved	---	
	03	Phase Z Input Reset Flag (ON for one cycle)	<b>ON</b> for one cycle when the counter PV is reset with the counter reset method set to a phase Z + software reset. <b>Note</b> This flag will turn ON for one cycle after the counter PV is reset if the phase Z signal (reset input) turns ON while the High-speed Counter Reset Bit (A610.01) is ON.	
	04	Absolute No. of Rotations Read Error Flag	<b>OFF:</b> No error <b>ON:</b> Error	
	05	Absolute No. of Rotations Read Completed Flag	<b>OFF:</b> Rotations being read or reading has not been executed. <b>ON:</b> Reading has been completed (Turned ON when serial reception of the number of rotations has been completed.)	
	06	Measuring Flag (measurement mode 1 or 2)	<b>OFF:</b> Changes in the counter PV or the counter frequency is not being measured. <b>ON:</b> Changes in the counter PV or the counter frequency is being measured.  In measurement mode 1, this flag will turn ON at the beginning of the sampling time after the Measurement Start Bit (A610.02) is turned ON. <b>Note</b> Valid when Counter Data Display in System Setup is set to Counter Movements (mode 1) or Frequency (mode 2).	
	07	High-speed Counter Operating Flag	<b>OFF:</b> Counter is not operating. <b>ON:</b> Counter is operating.	
	08	Count Latched Flag	<b>OFF:</b> Count has not been latched. <b>ON:</b> Latching the count has been completed for the latch input.	
	09 to 11	Reserved	---	
	12	Absolute Offset Preset Error Flag	<b>OFF:</b> No error occurred when saving the absolute offset. <b>ON:</b> An error occurred when saving the absolute offset.	
	13 to 15	Reserved	---	

Address	Bits	Name	Function	Controlled by	
A609	00	High-speed counter 2 status	Target Comparison In-progress Flag	Same as for high-speed counter 1.	Module
	01		PV Overflow/Underflow Flag		
	02		Reserved		
	03		Phase Z Input Reset Flag (ON for one cycle)		
	04		Absolute No. of Rotations Read Error Flag		
	05		Absolute No. of Rotations Read Completed Flag		
	06		Measuring Flag (measurement mode 1 or 2)		
	07		High-speed Counter Operating Flag		
	08		Count Latched Flag		
	09 to 11		Reserved		
	12		Absolute Offset Preset Error Flag		
	13 to 15		Reserved		

Address	Bits	Name	Function	Controlled by	
A610	00	High-speed counter 1 command bits	Start Bit	OFF: Stops counter operation. The counter PV will be maintained. ON: Starts counter operation. The counter PV will not be reset.	User
	01		Reset Bit	OFF: If a software reset is set in the System Setup, the counter PV will not be reset when internal I/O is refreshed in the Motion Control Module. If a phase Z + software reset is set, disables the phase Z input. ON: If a software reset is set in the System Setup, resets the counter PV to 0 when internal I/O is refreshed in the Motion Control Module. If a phase Z + software reset is set, enables the phase Z input.	
	02		Measurement Start Bit	OFF: Disables measuring changes in counter PV or the counter frequency. ON: Starts measuring changes in counter PV or the counter frequency. <b>Note</b> Measuring the high-speed counter frequency is possible only for high-speed counter 1. <b>Note</b> Valid when Counter Data Display in System Setup is set to Counter Movements (mode 1) or Frequency (mode 2).	
	03		Measurement Direction Bit (measurement mode 2)	OFF: Forward (up) ON: Reverse (down) This bit specifies the up/down direction of the pulse input for frequency measurement. <b>Note</b> Always set this bit before turning ON the Measurement Start Bit.	
	04		Range Comparison Results Clear Bit	OFF: Does not clear the execution results (A612) or output bit pattern (A613) from CTBL(882) execution for range comparison for the counter. ON: Clears the execution results (A612) or output bit pattern (A613) from CTBL(882) execution for range comparison for the counter.	
	05		Absolute Offset Preset Bit	OFF: Does not preset the offset. OFF to ON: Stores the number of multi-turns read from the Servo Driver and the number of initial incremental pulses as an offset in the Absolute Offset value in the System Setup. When establishing the machine origin, the position from the absolute encoder origin is set as the Absolute Offset in the System Setup as the machine origin.	
	06		Absolute Present Value Preset Bit	OFF: Disables the absolute present value preset. OFF to ON: Stores the Absolute PV in the counter 1 PV (A600 and A601). <b>Note</b> Refer to 7-7-6 Absolute Present Value for details on the absolute PV.	
	07		Absolute Number of Rotations Read Bit	OFF: Disables reading the number of rotations data from the Servo Driver. OFF to ON: Outputs the SEN output to the Servo Driver and receives the number of rotations data on the phase A input.	
	08		Latch Input 1 Enable Bit	OFF: Disables the exterior latch input 1 signal. ON: Enables the exterior latch input 1 signal.	
	09		Latch Input 2 Enable Bit	OFF: Disables the exterior latch input 2 signal. ON: Enables the exterior latch input 2 signal.	
	10 to 15	Reserved	---		

Address	Bits	Name	Function	Controlled by	
A611	00	High-speed counter 2 command bits	Start Bit	Same as command bits for high-speed counter 1.	User
	01		Reset Bit		
	02		Measurement Start Bit		
	03		Reserved		
	04		Range Comparison Results Clear Bit		
	05		Absolute Offset Preset Bit		
	06		Absolute Present Value Preset Bit		
	07		Absolute Number of Rotations Read Bit		
	08		Latch Input 1 Enable Bit		
	09		Latch Input 2 Enable Bit		
	10 to 15	Reserved			
A612	00 to 15	High-speed counter 1 monitor data	Range Comparison Execution Results Flags	Contains the CTBL(882) execution results for range comparison. Bits 00 to 15 correspond to ranges 1 to 16. OFF: No match ON: Match	Module
A613	00 to 15		Output Bit Pattern		
A614	00 to 15	High-speed counter 2 monitor data	Range Comparison Results	Same as for high-speed counter 1 monitor data.	
A615	00 to 15		Output Bit Pattern		

Address	Bits	Name	Function	Controlled by	
A620 to A621	00 to 15	Pulse Output 1 PV <b>Note</b> This item applies when the operation mode is relative pulse output, absolute pulse output in linear mode, absolute pulse output in circular mode, or electronic cam mode.	Contains the pulse output PV as an 8-digit hexadecimal number. Relative mode: 00000000 to FFFFFFFF hex Absolute linear mode: 80000000 to 7FFFFFFF hex Absolute circular mode: 00000000 to circular maximum count	Module	
		One-shot Pulse Output 1 ON Time <b>Note</b> This item applies when the operation mode is one-shot output mode.	Contains the time that the one-shot pulse output has been ON as an 8-digit hexadecimal number. 0000 0000 to 0000 270F (unit: set by STIM(980))		
		Pulse Time Measurement 1 <b>Note</b> This item applies when the operation mode is time measurement mode using a pulse counter.	Contains the time measured by the pulse counter as an 8-digit hexadecimal number. 0000 0000 to FFFF FFFF hex (unit: set by STIM(980))		
A622 to A623	00 to 15	Pulse Output 2 PV	Same as for Pulse Output 1 PV.		
		One-shot Pulse Output 2 ON Time	Same as for One-shot Pulse Output 1 ON time.		
		Pulse Time Measurement 2	Same as for Pulse Time Measurement 1.		
A624	00	Pulse Output 1 Status	Pulse Output Completed Flag	OFF: Pulse output not completed (OFF during pulse output). ON: Pulse output completed (ON when pulse distribution has been completed).	
	01		Pulse Output Set Flag	OFF: Pulse output amount not set by PULS(886). ON: Pulse output amount set by PULS(886).	
	02		Target Frequency Not Reached Flag	OFF: Target speed has been reached during pulse output for PLS2(887). ON: Decelerated before reaching the target speed during pulse output for PLS2(887).	
	03		Target Comparison Flag	OFF: Comparison stopped. ON: Comparison in progress.	
	04		Independent Pulse Output Flag	OFF: Pulses not being output or being output continuously. ON: Pulses being output.	
	05		PLS2 Positioning Flag	OFF: Not positioning. ON: Positioning in progress.	
	06		Accelerating/Decelerating Flag	OFF: No output or constant-speed output. ON: Acceleration or deceleration in progress for ACC(888) or PLS2(887).	
	07		Pulse Output Flag	OFF: Pulse output stopped. ON: Pulse output in progress.	
	08 to 15		Reserved	---	
A625	00	Pulse Output 2 Status	Pulse Output Completed Flag	Same as for Pulse Output 1 Status.	
	01		Pulse Output Set Flag		
	02		Target Frequency Not Reached Flag		
	03		Target Comparison Flag		
	04		Independent Pulse Output Flag		
	05		PLS2 Positioning Flag		
	06		Accelerating/Decelerating Flag		
	07		Pulse Output Flag		
	08 to 15		Reserved		

Address	Bits	Name	Function	Controlled by	
A626	00	Pulse Output 1 Command Bits	PV Reset Bit	OFF: Pulse output 1 PV not reset. ON: Resets pulse output 1 PV.	User
	01		Range Comparison Results Clear Bit	OFF: Does not clear the execution results (A630) or output bit pattern (A631) from CTBL(882) execution for range comparison for the pulse output PV. ON: Clears the execution results (A630) or output bit pattern (A631) from CTBL(882) execution for range comparison for the pulse output PV.	
	02 to 15		Reserved	---	
A627	00	Pulse Output 2 Command Bits	PV Reset Bit	Same as for Pulse Output 1 Command Bits.	
	01		Range Comparison Results Clear Bit		
	02 to 15		Reserved		
A628	00 to 06	Pulse Output Control Bits (Apply to both pulse outputs 1 and 2.)	Reserved	---	
	07		Speed Change Cycle Bit	OFF: Sets the speed change cycle to 2 ms during pulse output for ACC(888) or PLS2(887). ON: Sets the speed change cycle to 1 ms during pulse output for ACC(888) or PLS2(887).	
	08 to 13		Reserved	---	
	14		PLS2 Pulse Output Direction Priority Mode Bit	OFF: Sets Direction Priority Mode. In Direction Priority Mode, pulses are output only when the pulse output direction and the direction of the specified absolute position are the same. ON: Sets Absolute Position Priority Mode. In Absolute Position Priority Mode, pulses are always output in the direction of the specified absolute position.	
	15		Reserved	---	
A629	00 to 15	Reserved	---	---	
A630	00 to 15	Pulse Output 1 Monitor Data	Range Comparison Results	Contains the CTBL(882) execution results for range comparison. Bits 00 to 15 correspond to ranges 1 to 16. OFF: No match ON: Match	Module
A631	00 to 15		Output Bit Pattern	Contains the output bit pattern when a match is found for CTBL(882) execution results for range comparison <b>Note</b> If more than one match is found, an OR of the output bit patterns with matches will be stored here.	
A632	00 to 15	Pulse Output 2 Monitor Data	Range Comparison Results	Same as for Pulse Output 1 Monitor Data.	
A633	00 to 15		Output Bit Pattern		

## FQM1-MMA21 Motion Control Modules with Analog I/O

Address	Bits	Name	Function	Controlled by
A550	00 to 15	Analog Input PV	Contains the value input from the analog input port (using either the END refresh or immediate refresh) in 4-digit hexadecimal. The PV range depends on the input range: <ul style="list-style-type: none"> <li>• 0 to 10 V: FE70 to 20D0 hex</li> <li>• 0 to 5 V or 1 to 5 V: FF38 to 1068 hex</li> <li>• -10 to 10 V: DDA0 to 2260 hex</li> </ul>	Module
A552	00	Analog Input Status	User Adjustment Completed	OFF: Not adjusted ON: Adjustment completed
	01 to 06		Reserved	
	07		Analog Sampling Started	OFF: Not started ON: Started
	08		Factory Adjustment Data Error	OFF: No Error ON: Error (Checked at power ON.)
	09		User Adjustment Data Error	OFF: No Error ON: Error (Checked at power ON.)
	10 to 14		Reserved	
	15		Analog Sampling Overlap	OFF: Normal sampling ON: The next sampling operation occurred before the present sampling operation completed.
A559	01 to 15	Number of Analog Samples	Indicates the number of data samples actually input since sampling started.	
A560	00 to 15	Analog Output 1 Output Value	When an END refresh is selected, the 4-digit hexadecimal value set here by the user is output from analog output port 1. When immediate refreshing is selected, the 4-digit hexadecimal value being output from analog output port 1 is stored here for monitoring. The output value range depends on the output range, as shown below. <ul style="list-style-type: none"> <li>• 0 to 10 V, 0 to 5 V or 1 to 5 V: FF38 to 1068 hex</li> <li>• -10 to 10 V: EA84 to 157C hex</li> </ul> <b>Note</b> 1. Set the analog output method (END or immediate refreshing) with the System Setup's output method setting. A setting of 0 hex specifies an END refresh. This setting applies to both analog output 1 and 2. 2. Specify the output range with the output 1 setting.	With immediate refresh: Module With END refresh: User
A561	00 to 15	Analog Output 2 Output Value	This word has the same settings as the analog output 1 output value (A560), above. (When an END refresh is selected, set the value to output from analog output port 2. When an immediate refresh is selected, the output value is stored here for monitoring.) <b>Note</b> 1. Set the analog output method (END or immediate refresh) with the System Setup's output method setting. A setting of 0 hex specifies an END refresh. This setting applies to both analog output 1 and 2. 2. Specify the output range with the output 2 setting.	



Address	Bits	Name	Function		Controlled by
A562	00	Analog Output 1 Flags	User Adjustment Completed	Initial value is 0. Set to 1 if user performs offset/gain adjustment and Returns to factory default setting of 0 if adjustment value is cleared.	Module
	01 to 03		Reserved	---	
	04		Operating	ON: ON while the analog output is being changed by ACC(888). OFF: Turned OFF when target value is reached.	
	05 to 07		Reserved	---	
	08		Output SV Error	ON: ON when the output SV setting is outside of the allowed setting range. OFF: OFF when the output SV is within range. <b>Note</b> Only for END refresh.	
	09 to 11		Reserved	---	
	12		Factory Adjustment Value Error	ON: ON when the factory-set data stored in flash memory is invalid. OFF: OFF when the factory-set data stored in flash memory is normal.	
	13		Reserved	---	
	14		User Adjustment Value Error	ON: ON when the user-set adjustment value stored in flash memory is invalid. OFF: OFF when the user-set adjustment value stored in flash memory is normal.	
	15		Reserved	---	
A563	00	Analog Output 2 Flags	User Adjustment Completed	Same as for Analog Output 1 Flags.	
	01 to 03		Reserved		
	04		Operating		
	05 to 07		Reserved		
	08		Output SV Error		
	09 to 11		Reserved		
	12		Factory Adjustment Value Error		
	13		Reserved		
	14		User Adjustment Value Error		
	15		Reserved		

Address	Bits	Name		Function		Controlled by	
A564	00	Analog Output 1	Conversion Enable Bit	ON: Enables D/A conversion (enables analog output). OFF: Disables DA conversion (analog values output according to Output Stop Function specification in System Setup). <b>Note</b> This bit is cleared when the Modules operating mode is changed between RUN or MONITOR mode and PROGRAM mode.		User	
	01 to 15	Reserved		---		---	
A565	00	Analog Output 2	Conversion Enable Bit	ON: Enables D/A conversion (enables analog output). OFF: Disables DA conversion (analog values output according to Output Stop Function specification in System Setup). <b>Note</b> This bit is cleared when the Modules operating mode is changed between RUN or MONITOR mode and PROGRAM mode.		User	
	01 to 15	Reserved		---		---	
A570	00	Adjustment Mode Command Bits (Effective only when A575 is 5A5A hex.)	Adjustment Enable	Analog Input	OFF: Adjustment disabled. ON: Adjustment enabled.	User	
	01			Reserved	When one of these bits is turned ON, the default value (offset or gain value) corresponding to the selected I/O signal range is transferred to Adjustment Mode Monitor Area (A572 and A573).		
	02			Analog Output 1			
	03			Analog Output 2			
	04 to 06		Reserved				
	07		Adjustment Mode Specifier	OFF: Offset adjustment ON: Gain adjustment			
	08 to 11		Reserved				
	12		Adjustment Value Increment	While this bit is ON, the offset or gain value will be incremented by one resolution unit each 0.5 ms.			
	13		Adjustment Value Decrement	While this bit is ON, the offset or gain value will be decremented by one resolution unit each 0.5 ms.			
	14		Adjustment Value Clear	OFF to ON: Clears the adjustment data to the factory defaults.			
	15		Adjustment Value Set	OFF to ON: Reads the present value in the Adjustment Mode Monitor Area (A572 and A573) and saves this value to flash memory. This adjustment value will be used for the next normal mode operation.			
A571	00	Adjustment Mode Status	Adjustment Operation Error	ON when an operational error has been made, such as turning ON both the Analog Input and Analog Output 2 Adjustment Enable Bits at the same time.		Module	
	01 to 14		Reserved				
	15		Adjustment Mode Started	ON during adjustment mode operation (when A575 contains 5A5A hex).			
A572	00 to 15	Adjustment Mode Monitor (Effective only when A575 is 5A5A hex.)	Both Analog Input and Analog Outputs	Setting Offset Monitor	The values in these words can be overwritten directly, without using the Adjustment Value Increment/Decrement Bits.  • -10 to 10 V: FE0C to 01F4 hex • 0 to 10 V, 0 to 5 V, 1 to 5 V: FF38 to 00C8 hex	Module/User	
A573	00 to 15			Gain Value Monitor			• -10 to 10 V: 1194 to 157C hex • 0 to 10 V, 0 to 5 V, 1 to 5 V: 0ED8 to 1068 hex
A574	00 to 15		Analog Inputs	Number of Average Value Samples in Adjustment Mode			Indicates the number of values to be averaged to obtain the Offset/Gain Value Monitor values in adjustment mode. The number of samples can be set between 0000 and 0040 hex (0 to 64). Set this parameter before turning ON the Adjustment Enable Bit.
A575	00 to 15	Adjustment Mode Password		5A5A hex: Adjustment mode enabled. Other value: Adjustment mode disabled.		User	

Address	Bits	Name			Function	Controlled by
A600	00 to 15	High-speed Counter 1 PV			Range: 8000 0000 to 7FFF FFFF <b>Note</b> For a Linear Counter, high-speed counter overflows/underflows are checked when the PV is read (i.e., when Module internal I/O is refreshed).	Module
A601	00 to 15					
A602	00 to 15	High-speed Counter 2 PV				
A603	00 to 15					
A604 to A605	00 to 15	High-speed Counter 1	For following counter modes	PV of absolute number of rotations	Contains the number of rotations data (PV) read from the Encoder when the SEN signal is input to the Servo Driver. 8000 0000 to 7FFF FFFF hex	
			<ul style="list-style-type: none"> <li>• Absolute linear (CW-)</li> <li>• Absolute circular</li> <li>• Absolute linear (CW+)</li> </ul>			
			For following counter modes	Monitor data	<ul style="list-style-type: none"> <li>• When monitoring counter movements (mode 1), contains the absolute value of the amount of change in the PV of the high-speed counter over the specified sampling time as a 8-digit hexadecimal value (0000 0000 to FFFF FFFF hex).</li> <li>• When monitoring the counter frequency (mode 2), contains the frequency of the high-speed counter calculated from the PV of the high-speed counter between 0 and 7A120 hex (0 and 500 kHz).</li> </ul>	
A606 to A607	00 to 15	High-speed Counter 2	For following counter modes	PV of absolute number of rotations	Same as for A604 and A605 for high-speed counter 1 except that measuring the high-speed counter frequency is not possible for high-speed counter 2.	
			<ul style="list-style-type: none"> <li>• Absolute linear (CW-)</li> <li>• Absolute circular</li> <li>• Absolute linear (CW+)</li> </ul>			
			For following counter modes	Monitor data		
			<ul style="list-style-type: none"> <li>• Linear counter</li> <li>• Circular counter</li> </ul>			

Address	Bits	Name	Function	Controlled by
A608	00	High-speed counter 1 status	Target Comparison In-progress Flag  <b>OFF:</b> Target value comparison is not being performed for CTBL(882). <b>Note</b> This flag is always OFF for range comparison. <b>ON:</b> Target value comparison is being performed for CTBL(882). <b>Note</b> Target comparison is continued without interruption once it has been started (as opposed to range comparison), so this flag can be used to check whether target comparison is in progress.	Module
	01		PV Overflow/Underflow Flag  <b>OFF:</b> There is no counter overflow or underflow in Linear Counter Mode. This flag will always be OFF in Circular Counter Mode. <b>ON:</b> There is a counter overflow or underflow in Linear Counter Mode. The counter PV will be fixed at the overflow or underflow limit. This flag will be cleared when the High-speed Counter Start Bit is turned OFF.	
	02	Reserved	---	
	03	Phase Z Input Reset Flag (ON for one cycle)	<b>ON</b> for one cycle when the counter PV is reset with the counter reset method set to a phase Z + software reset. <b>Note</b> This flag will turn ON for one cycle after the counter PV is reset if the phase Z signal (reset input) turns ON while the High-speed Counter Reset Bit (A610.01) is ON.	
	04		Absolute No. of Rotations Read Error Flag <b>OFF:</b> No error <b>ON:</b> Error	
	05	Absolute No. of Rotations Read Completed Flag <b>OFF:</b> Rotations being read or reading has not been executed. <b>ON:</b> Reading has been completed (Turned ON when serial reception of the number of rotations has been completed.)		
	06	Measuring Flag (measurement mode 1 or 2)  <b>OFF:</b> Changes in the counter PV or the counter frequency is not being measured. <b>ON:</b> Changes in the counter PV or the counter frequency is being measured.  In measurement mode 1, this flag will turn ON at the beginning of the sampling time after the Measurement Start Bit (A610.02) is turned ON. <b>Note</b> Valid when Counter Data Display in System Setup is set to Counter Movements (mode 1) or Frequency (mode 2).		
	07	High-speed Counter Operating Flag <b>OFF:</b> Counter is not operating. <b>ON:</b> Counter is operating.		
	08	Count Latched Flag <b>OFF:</b> Count has not been latched. <b>ON:</b> Latching the count has been completed for the latch input.		
	09 to 11	Reserved	---	
	12	Absolute Offset Preset Error Flag <b>OFF:</b> No error occurred when saving the absolute offset. <b>ON:</b> An error occurred when saving the absolute offset.		
	13 to 15	Reserved	---	

Address	Bits	Name	Function	Controlled by	
A609	00	High-speed counter 2 status	Target Comparison In-progress Flag	Same as for high-speed counter 1.	Module
	01		PV Overflow/Underflow Flag		
	02		Reserved		
	03		Phase Z Input Reset Flag (ON for one cycle)		
	04		Absolute No. of Rotations Read Error Flag		
	05		Absolute No. of Rotations Read Completed Flag		
	06		Measuring Flag (measurement mode 1 or 2)		
	07		High-speed Counter Operating Flag		
	08		Count Latched Flag		
	09 to 11		Reserved		
	12		Absolute Offset Preset Error Flag		
	13 to 15		Reserved		

Address	Bits	Name	Function	Controlled by	
A610	00	High-speed counter 1 command bits	Start Bit	OFF: Stops counter operation. The counter PV will be maintained. ON: Starts counter operation. The counter PV will not be reset.	User
	01		Reset Bit	OFF: If a software reset is set in the System Setup, the counter PV will not be reset when internal I/O is refreshed in the Motion Control Module. If a phase Z + software reset is set, disables the phase Z input. ON: If a software reset is set in the System Setup, resets the counter PV to 0 when internal I/O is refreshed in the Motion Control Module. If a phase Z + software reset is set, enables the phase Z input.	
	02		Measurement Start Bit	OFF: Disables measuring changes in counter PV or the counter frequency. ON: Starts measuring changes in counter PV or the counter frequency. <b>Note</b> Measuring the high-speed counter frequency is possible only for high-speed counter 1. <b>Note</b> Valid when Counter Data Display in System Setup is set to Counter Movements (mode 1) or Frequency (mode 2).	
	03		Measurement Direction Bit (measurement mode 2)	OFF: Forward (up) ON: Reverse (down) This bit specifies the up/down direction of the pulse input for frequency measurement. <b>Note</b> Always set this bit before turning ON the Measurement Start Bit.	
	04		Range Comparison Results Clear Bit	OFF: Does not clear the execution results (A612) or output bit pattern (A613) from CTBL(882) execution for range comparison for the counter. ON: Clears the execution results (A612) or output bit pattern (A613) from CTBL(882) execution for range comparison for the counter.	
	05		Absolute Offset Preset Bit	OFF: Does not preset the offset. OFF to ON: Stores the number of multi-turns read from the Servo Driver and the number of initial incremental pulses as an offset in the Absolute Offset value in the System Setup. When establishing the machine origin, the position from the absolute encoder origin is set as the Absolute Offset in the System Setup as the machine origin.	
	06		Absolute Present Value Preset Bit	OFF: Disables the absolute present value preset. OFF to ON: Stores the Absolute PV in the counter 1 PV (A600 and A601). <b>Note</b> Refer to 7-7-6 <i>Absolute Present Value</i> for details on the absolute PV.	
	07		Absolute Number of Rotations Read Bit	OFF: Disables reading the number of rotations data from the Servo Driver. OFF to ON: Outputs the SEN output to the Servo Driver and receives the number of rotations data on the phase A input.	
	08		Latch Input 1 Enable Bit	OFF: Disables the external latch input 1 signal. ON: Enables the external latch input 1 signal.	
	09		Latch Input 2 Enable Bit	OFF: Disables the external latch input 2 signal. ON: Enables the external latch input 2 signal.	
	10 to 15	Reserved	---		

Address	Bits	Name	Function	Controlled by	
A611	00	High-speed counter 2 command bits	Start Bit	Same as command bits for high-speed counter 1.	User
	01		Reset Bit		
	02		Measurement Start Bit		
	03		Reserved		
	04		Range Comparison Results Clear Bit		
	05		Absolute Offset Preset Bit		
	06		Absolute Present Value Preset Bit		
	07		Absolute Number of Rotations Read Bit		
	08		Latch Input 1 Enable Bit		
	09		Latch Input 2 Enable Bit		
	10 to 15	Reserved			
A612	00 to 15	High-speed counter 1 monitor data	Range Comparison Execution Results Flags	Contains the CTBL(882) execution results for range comparison. Bits 00 to 15 correspond to ranges 1 to 16. OFF: No match ON: Match	Module
A613	00 to 15		Output Bit Pattern		
A614	00 to 15	High-speed counter 2 monitor data	Range Comparison Results	Same as for high-speed counter 1 monitor data.	
A615	00 to 15		Output Bit Pattern		

## Allocations Related to Built-in Inputs

### Input Interrupts

Address	Bits	Name	Function	Controlled by
A520	00 to 15	Interrupt Counter 0 Counter SV	Used for interrupt input 0 in counter mode. Sets the count value at which the interrupt task will start. Interrupt task 000 will start when interrupt counter 0 has counted this number of pulses. Setting range: 0000 to FFFF	User
A521	00 to 15	Interrupt Counter 1 Counter SV	Used for interrupt input 1 in counter mode. Sets the count value at which the interrupt task will start. Interrupt task 001 will start when interrupt counter 1 has counted this number of pulses. Setting range: 0000 to FFFF	
A522	00 to 15	Interrupt Counter 2 Counter SV	Used for interrupt input 2 in counter mode. Sets the count value at which the interrupt task will start. Interrupt task 002 will start when interrupt counter 2 has counted this number of pulses. Setting range: 0000 to FFFF	
A523	00 to 15	Interrupt Counter 3 Counter SV	Used for interrupt input 3 in counter mode. Sets the count value at which the interrupt task will start. Interrupt task 003 will start when interrupt counter 3 has counted this number of pulses. Setting range: 0000 to FFFF	

Address	Bits	Name	Function	Controlled by
A524	00 to 15	Interrupt Counter 0 Counter PV	These words contain the interrupt counter PVs for interrupt input 0 to 3 operating in counter mode. The counter PV starts decrementing from the counter SV. When the counter PV reaches the 0, the PV is automatically reset to the SV. Range: 0000 to FFFF	Module
A525	00 to 15	Interrupt Counter 1 Counter PV		
A526	00 to 15	Interrupt Counter 2 Counter PV		
A527	00 to 15	Interrupt Counter 3 Counter PV		

## Allocations That Are the Same for the Coordinator Module and Motion Control Modules

### System Flags

Address	Bits	Name	Function	Controlled by																					
A000 to A015	00 to 15	Subroutine Input Condition Flags	<p>These flags contain the status of the input condition for JSB(982) when JSB(982) is used to call a subroutine.</p> <table border="1"> <thead> <tr> <th colspan="2">Address</th> <th>Corresponding subroutines</th> </tr> <tr> <th>Word</th> <th>Bits</th> <td></td> </tr> </thead> <tbody> <tr> <td>A000</td> <td>00 to 15</td> <td>SBN000 to SBN015</td> </tr> <tr> <td>A001</td> <td>00 to 15</td> <td>SBN016 to SBN031</td> </tr> <tr> <td>A002</td> <td>00 to 15</td> <td>SBN032 to SBN047</td> </tr> <tr> <td>to</td> <td>to</td> <td>to</td> </tr> <tr> <td>A015</td> <td>00 to 15</td> <td>SBN240 to SBN255</td> </tr> </tbody> </table>	Address		Corresponding subroutines	Word	Bits		A000	00 to 15	SBN000 to SBN015	A001	00 to 15	SBN016 to SBN031	A002	00 to 15	SBN032 to SBN047	to	to	to	A015	00 to 15	SBN240 to SBN255	Module
Address		Corresponding subroutines																							
Word	Bits																								
A000	00 to 15	SBN000 to SBN015																							
A001	00 to 15	SBN016 to SBN031																							
A002	00 to 15	SBN032 to SBN047																							
to	to	to																							
A015	00 to 15	SBN240 to SBN255																							
A206 to A207	00 to 15	Maximum Cycle Time	These words store the maximum cycle time every cycle. The cycle time is recorded in 8-digit hexadecimal (unit: 0.01 ms).																						
A208 to A209	00 to 15	Present Cycle Time	These words store the present cycle time every cycle in 8-digit hexadecimal (unit: 0.01 ms).																						

### Program Error Flags

Address	Bits	Name	Function	Controlled by
A401	09	Program Error Flag (fatal error)	ON when program contents are incorrect. Module operation will stop.	Module
A405	11	No END Error Flag	ON when there isn't an END(001) instruction in each program within a task.	
	12	Task Error Flag	ON when a task error has occurred. The following conditions generate a task error. There isn't a program allocated to the task.	
	13	Differentiation Overflow Error Flag	The allowed value for Differentiation Flags which correspond to differentiation instructions has been exceeded.	
	14	Illegal Instruction Error Flag	ON when a program that cannot be executed has been stored.	
	15	UM Overflow Error Flag	ON when the last address in UM (User Memory) has been exceeded.	

### Other Error Flags and Bits

#### Error Log and Error Code

Address	Bits	Name	Function	Controlled by
A100 to A199	00 to 15	Error Log Area	When an error has occurred, the error code and error contents are stored in the Error Log Area.	Module
A408	00 to 15	Error Log Pointer	When an error occurs, the Error Log Pointer (binary) is incremented by 1 to indicate the location where the next error will be recorded as an offset from the beginning of the Error Log Area (A100 to A199).	



Address	Bits	Name	Function	Controlled by
A500	14	Error Log Pointer Reset and Memory Not Held Flag OFF Bit	The error log pointer in A408 is reset to 0000 hex and Memory Not Held Flag (A404.14) is turned OFF when this bit is turned ON.	User
A400	00 to 15	Error code	When a non-fatal error (user-defined FAL(006) or system error) or a fatal error (user-defined FALS(007) or system error) occurs, the hexadecimal error code is written to this word.	Module

**FAL/FALS Errors**

Address	Bits	Name	Function	Controlled by
A401	06	FALS Error Flag (fatal error)	Turns ON when a non-fatal error is generated by the FALS(006) instruction. The FQM1 will stop operating.	Module
A402	15	FAL Error Flag (non-fatal error)	Turns ON when a non-fatal error is generated by executing FAL(006). The FQM1 will continue operating.	

**Memory Errors**

Address	Bits	Name	Function	Controlled by
A401	15	Memory Error Flag (fatal error)	Turns ON when there is an error in the memory. FQM1 operation will stop and the ERR indicators on the front of the Modules will light.	Module
A403	00	UM Error Flag	Turns ON when there is an error in the user memory.	
	04	System Setup Error Flag	Turns ON when there is an error in the System Setup in the Coordinator Module or Motion Control Module.	
	10	Flash Memory Error Flag	Turns ON when the flash memory is physically destroyed.	
	13	Analog Offset/Gain Error Flag	Turns ON when there is an error in the analog I/O offset/gain adjustment value in flash memory.	
	14	Flash Memory DM Checksum Error Flag	Turns ON when there is an error in the DM Area data backed up in flash memory in the Coordinator Module.	
A404	14	Memory Not Held Flag	Turns ON when corruption is found in the check performed after turning ON power in the areas backed up during power interruptions (DM Area (Coordinator Module only) and Error Log Area).	

**System Setup**

Address	Bits	Name	Function	Controlled by
A402	10	System Setup Error Flag	Turns ON when there is a setting error in the System Setup.	Module
A409	00 to 15	System Setup Error Location	When there is a setting error in the System Setup, the location of that error is written to A409 in 4-digit hexadecimal.	

**I/O Errors**

Address	Bits	Name	Function	Controlled by
A401	10	I/O Setting Error Flag	Turns ON when more than four Motion Control Modules are connected to the Coordinator Module.	Module

**Module Errors**

Address	Bits	Name	Function	Controlled by
A402	05	Motion Control Module Monitoring Error Flag (Coordinator Module only)	Turns ON in the Coordinator Module when a system error, such as a WDT error, occurs in any of the Motion Control Modules.	Module
	13	Coordinator Module WDT Error Flag (Motion Control Modules only)	Turns ON in the Motion Control Modules when a WDT error occurs in the Coordinator Module.	
	14	Coordinator Module Fatal Error Flag (Motion Control Modules only)	Turns ON in the Motion Control Modules when a fatal error occurs in the Coordinator Module.	

**Other**

Address	Bits	Name	Function	Controlled by
A401	08	Cycle Time Too Long Flag (fatal error)	Turns ON if the cycle time exceeds the maximum cycle time set in the System Setup (the Watch Cycle Time).	Module
A404	05	Constant Cycle Time Exceeded Flag	Turns ON when the actual cycle time exceeds the specified constant (minimum) cycle time.	
	06	Sync Cycle Time Too Long Flag	Turns ON when one of the Modules exceeds the specified sync cycle time. (Coordinator Module only)	
A509	15	Constant Cycle Time Exceeded Error Clear Bit	Used to enable the constant cycle time function again after the constant cycle time has been exceeded.	User

**Allocations Related to DM Data Transfer (Coordinator Module Only)**

Address	Bits	Name	Function	Controlled by
A530	00	DM Write Request Bit (Coordinator Module to Motion Control Module)	DM data transfer is executed from the Coordinator Module to Motion Control Module when this bit turns ON.	User
	01	DM Read Request Bit (Motion Control Module to Coordinator Module)	DM data transfer is executed from the Motion Control Module to Coordinator Module when this bit turns ON.	
A531	00 to 15	Slot No. of Motion Control Module for DM Transfer	Specifies the slot number (in 4-digit hexadecimal) for the Motion Control Module with which DM data is to be transferred. 0001: Motion Control Module #1 0002: Motion Control Module #2 0003: Motion Control Module #3 0004: Motion Control Module #4	
A532	00 to 15	DM Transfer Size (number of words)	Specifies the size, in number of words, of the DM data to be transferred. 0001 to 01F3 hex (1 to 499 words)	
A533	00 to 15	First DM Transfer Source Word	Specifies the first address of the DM transfer source in the Coordinator Module or Motion Control Module. 0000 to 7FFF hex	
A534	00 to 15	First DM Transfer Destination Word	Specifies the first address of the DM transfer destination in the Coordinator Module or Motion Control Module. 0000 to 7FFF hex	
A535	14	Transfer Error Flag	Turns ON when a DM data transfer error occurs.	
	15	Transfer Busy Flag	Turns ON during DM data transfer and turns OFF when the transfer has been completed.	

**Communications****Peripheral Port**

Address	Bits	Name	Function	Controlled by
A412	02 to 05	Peripheral Port Error Flags	Indicates the status of the error flags that turn ON when an error has occurred at the peripheral port.	Module
	08	Peripheral Port Communications Error Flag	Turns ON when a communications error has occurred at the peripheral port.	
	15	Peripheral Port Settings Changing Flag	Turns ON while the peripheral port's communications settings are being changed.	
A502	01	Peripheral Port Restart Bit	Turn this bit ON to restart the peripheral port. This bit is turned OFF automatically when the restart processing is completed.	User

**RS-232C Port**

Address	Bits	Name	Function	Controlled by
A410	02 to 05	RS-232C Port Error Flags	Indicates the status of the error flags that turn ON when an error has occurred at the RS-232C port.	Module
	08	RS-232C Port Communications Error Flag	Turns ON when a communications error has occurred at the RS-232C port.	
	09	RS-232C Port Send Ready Flag (no-protocol mode)	Turns ON when the RS-232C port is ready to send data in no-protocol mode.	
	10	RS-232C Port Reception Completed Flag (no-protocol mode)	Turns ON when the RS-232C port has completed the reception in no-protocol mode.	
	11	RS-232C Port Reception Overflow Flag (no-protocol mode)	Turns ON when a data overflow occurred during reception through the RS-232C port in no-protocol mode.	
	15	RS-232C Port Settings Changing Flag	Turns ON while the RS-232C port's communications settings are being changed.	
A411	00 to 15	RS-232C Port Reception Counter (no-protocol mode)	Indicates (in binary) the number of bytes of data received when the RS-232C port is in no-protocol mode.	
A502	00	RS-232C Port Restart Bit	Turn this bit ON to restart the RS-232C port. This bit is turned OFF automatically when the restart processing is completed.	User

**RS-422A Port**

Address	Bits	Name	Function	Controlled by
A414	02 to 05	RS-422A Port Error Flags	Indicates the status the error flags that turn ON when an error has occurred at the RS-422A port.	Module
	08	RS-422A Port Communications Error Flag	Turns ON when a communications error has occurred at the RS-422A port.	
	09	RS-422A Port Send Ready Flag (no-protocol mode)	Turns ON when the RS-422A port is ready to send data in no-protocol mode.	
	10	RS-422A Port Reception Completed Flag (no-protocol mode)	Turns ON when the RS-422A port has completed the reception in no-protocol mode.	
	11	RS-422A Port Reception Overflow Flag (no-protocol mode)	Turns ON when a data overflow occurred during reception through the RS-422A port in no-protocol mode.	
	15	RS-422A Port Settings Changing Flag	Turns ON while the RS-422A port's communications settings are being changed.	
A415	00 to 15	RS-422A Port Reception Counter (no-protocol mode)	Indicates (in binary) the number of bytes of data received when the RS-422A port is in no-protocol mode.	
A502	02	RS-422A Port Restart Bit	Turn this bit ON to restart the RS-422A port. This bit is turned OFF automatically when the restart processing is completed.	User

**Allocations Directly Related to Instructions**

Address	Bits	Name	Function	Controlled by
A200	11	First Cycle Flag	ON for one cycle after FQM1 operation begins.	Module
	12	Step Flag	ON for one cycle when step execution is started with STEP(008).	
A510 to A514	00 to 15	Macro Area Input Words	Before the subroutine specified in MCRO(099) is executed, the contents of the five words specified in the operand to be passed to the subroutine are stored here.	
A515 to A519	00 to 15	Macro Area Output Words	After the subroutine specified in MCRO(099) has been executed, the results of the subroutine are transferred to these five words.	

## Built-in I/O Allocations

The Coordinator Module and Motion Control Modules all have built-in I/O. The I/O Area allocations to the contacts on the Modules are given in the following tables.

### Coordinator Module Built-in I/O Allocations

#### Inputs (40-pin General-purpose I/O Connector)

Name	I/O Area allocations
External input 0	CIO 0000.00
External input 1	CIO 0000.01
to	to
External input 15	CIO 0000.15

#### Outputs (40-pin General-purpose I/O Connector)

Name	I/O Area allocations
External output 0	CIO 0001.00
External output 1	CIO 0001.01
to	to
External output 7	CIO 0010.07

### Motion Control Module Built-in I/O Allocations

#### Inputs (26-pin General-purpose I/O Connector)

Name	I/O Area allocations
External input 0 (interrupt)	CIO 0000.00
External input 1 (interrupt)	CIO 0000.01
External input 2 (interrupt)	CIO 0000.02
External input 3 (interrupt)	CIO 0000.03
to	to
External input 11	CIO 0000.11

#### Outputs (26-pin General-purpose I/O Connector)

Name	I/O Area allocations
External output 0	CIO 0001.00
External output 1	CIO 0001.01
to	to
External output 7	CIO 0001.07

# Appendix D

## Auxiliary Area Allocations

### Auxiliary Area Allocations in Order of Address

The following table lists the Auxiliary Area allocations in order of address. Refer to *Auxiliary Area Allocations by Function* on page 327 for a list of allocations by function.

Read-only Words: A000 to A447, Read/Write Words: A448 to A649

Address	Bits	Name	Function																				
A000 to A015	00 to 15	Subroutine Input Condition Flags	<p>These flags contain the status of the input condition for JSB(982) when JSB(982) is used to call a subroutine.</p> <table border="1" style="width: 100%; border-collapse: collapse;"> <thead> <tr> <th colspan="2">Address</th> <th rowspan="2">Corresponding subroutines</th> </tr> <tr> <th>Word</th> <th>Bits</th> </tr> </thead> <tbody> <tr> <td>A000</td> <td>00 to 15</td> <td>SBN000 to SBN015</td> </tr> <tr> <td>A001</td> <td>00 to 15</td> <td>SBN016 to SBN031</td> </tr> <tr> <td>A002</td> <td>00 to 15</td> <td>SBN032 to SBN047</td> </tr> <tr> <td>to</td> <td>to</td> <td>to</td> </tr> <tr> <td>A015</td> <td>00 to 15</td> <td>SBN240 to SBN255</td> </tr> </tbody> </table>	Address		Corresponding subroutines	Word	Bits	A000	00 to 15	SBN000 to SBN015	A001	00 to 15	SBN016 to SBN031	A002	00 to 15	SBN032 to SBN047	to	to	to	A015	00 to 15	SBN240 to SBN255
				Address			Corresponding subroutines																
				Word	Bits																		
				A000	00 to 15	SBN000 to SBN015																	
				A001	00 to 15	SBN016 to SBN031																	
				A002	00 to 15	SBN032 to SBN047																	
to	to	to																					
A015	00 to 15	SBN240 to SBN255																					
A100 to A199	00 to 15	Error Log Area	When an error has occurred, the error code and error contents are stored in the Error Log Area.																				
A200	11	First Cycle Flag	ON for one cycle after FQM1 operation begins.																				
	12	Step Flag	ON for one cycle when step execution is started with STEP(008).																				
A202	00	Motion Control Module slot 1	ON if the Motion Control Module is in slot 1.																				
	01	Motion Control Module slot 2	ON if the Motion Control Module is in slot 2.																				
	02	Motion Control Module slot 3	ON if the Motion Control Module is in slot 3.																				
	03	Motion Control Module slot 4	ON if the Motion Control Module is in slot 4.																				
A206 to A207	00 to 15	Maximum Cycle Time	These words store the maximum cycle time every cycle. The cycle time is recorded in 8-digit hexadecimal (unit: 0.01 ms).																				
A208 to A209	00 to 15	Present Cycle Time	These words stores the present cycle time every cycle in 8-digit hexadecimal (unit: 0.01 ms).																				
A400	00 to 15	Error code	When a non-fatal error (user-defined FAL(006) or system error) or a fatal error (user-defined FALS(007) or system error) occurs, the hexadecimal error code is written to this word.																				
A401	06	FALS Error Flag (fatal error)	Turns ON when a non-fatal error is generated by the FALS(006) instruction. The FQM1 will stop operating.																				
	08	Cycle Time Too Long Flag (fatal error)	Turns ON if the cycle time exceeds the maximum cycle time set in the System Setup (the Watch Cycle Time).																				
	09	Program Error Flag (fatal error)	ON when program contents are incorrect. Module operation will stop.																				
	10	I/O Setting Error Flag	Turns ON when more than four Motion Control Modules are connected to the Coordinator Module.																				
	14	I/O Bus Error Flag	Turns ON when an error occurs in transferring data between the Coordinator Module and Motion Control Modules. Module operation will stop.																				
	15	Memory Error Flag (fatal error)	Turns ON when there is an error in the memory. FQM1 operation will stop and the ERR indicators on the front of the Modules will light.																				
A402	05	Motion Control Module Monitoring Error Flag (Coordinator Module only)	Turns ON in the Coordinator Module when a system error, such as a WDT error, occurs in any of the Motion Control Modules.																				
	10	System Setup Error Flag	Turns ON when there is a setting error in the System Setup.																				
	13	Coordinator Module WDT Error Flag (Motion Control Modules only)	Turns ON in the Motion Control Modules when a WDT error occurs in the Coordinator Module.																				
	14	Coordinator Module Fatal Error Flag (Motion Control Modules only)	Turns ON in the Motion Control Modules when a fatal error occurs in the Coordinator Module.																				
	15	FAL Error Flag (non-fatal error)	Turns ON when a non-fatal error is generated by executing FAL(006). The FQM1 will continue operating.																				

Address	Bits	Name	Function	
A403	00	UM Error Flag	Turns ON when there is an error in the user memory.	
	04	System Setup Error Flag	Turns ON when there is an error in the System Setup in the Coordinator Module or Motion Control Module.	
	10	Flash Memory Error Flag	Turns ON when the flash memory is physically destroyed.	
	13	Analog Offset/Gain Error Flag	Turns ON when there is an error in the analog I/O offset/gain adjustment value in flash memory.	
	14	Flash Memory DM Checksum Error Flag (Coordinator Module only)	Turns ON when there is an error in the DM Area data backed up in flash memory in the Coordinator Module.	
A404	05	Constant Cycle Time Exceeded Flag	Turns ON when the actual cycle time exceeds the specified constant (minimum) cycle time.	
	06	Sync Cycle Time Too Long Flag	Turns ON when one of the Modules exceeds the specified sync cycle time. (Coordinator Module only)	
	14	Memory Not Held Flag	Turns ON when corruption is found in the check performed after turning ON power in the areas backed up during power interruptions (DM Area (Coordinator Module only) and Error Log Area).	
A405	11	No END Error Flag	ON when there isn't an END(001) instruction in each program within a task.	
	12	Task Error Flag	ON when a task error has occurred. The following conditions generate a task error. There isn't a program allocated to the task.	
	13	Differentiation Overflow Error Flag	The allowed value for Differentiation Flags which correspond to differentiation instructions has been exceeded.	
	14	Illegal Instruction Error Flag	ON when a program that cannot be executed has been stored.	
	15	UM Overflow Error Flag	ON when the last address in UM (User Memory) has been exceeded.	
A408	00 to 15	Error Log Pointer	When an error occurs, the Error Log Pointer (binary) is incremented by 1 to indicate the location where the next error will be recorded as an offset from the beginning of the Error Log Area (A100 to A199).	
A409	00 to 15	System Setup Error Location	When there is a setting error in the System Setup, the location of that error is written to A409 in 4-digit hexadecimal.	
A410	02	RS-232C Port Error Flags	Parity Error Flag	These error flags turn ON when an error has occurred at the RS-232C port.
	03		Framing Error Flag	
	04		Overrun Error Flag	
	05		Timeout Error Flag	
	08	RS-232C Port Communications Error Flag	Turns ON when a communications error has occurred at the RS-232C port.	
	09	RS-232C Port Send Ready Flag (no-protocol mode)	Turns ON when the RS-232C port is ready to send data in no-protocol mode.	
	10	RS-232C Port Reception Completed Flag (no-protocol mode)	Turns ON when the RS-232C port has completed the reception in no-protocol mode.	
	11	RS-232C Port Reception Overflow Flag (no-protocol mode)	Turns ON when a data overflow occurred during reception through the RS-232C port in no-protocol mode.	
15	RS-232C Port Settings Changing Flag	Turns ON while the RS-232C port's communications settings are being changed.		
A411	00 to 15	RS-232C Port Reception Counter (no-protocol mode)	Indicates (in binary) the number of bytes of data received when the RS-232C port is in no-protocol mode.	
A412	02	Peripheral Port Error Flags	Parity Error Flag	These error flags turn ON when an error has occurred at the peripheral port.
	03		Framing Error Flag	
	04		Overrun Error Flag	
	05		Timeout Error Flag	
	08	Peripheral Port Communications Error Flag	Turns ON when a communications error has occurred at the peripheral port.	
	15	Peripheral Port Settings Changing Flag	Turns ON while the peripheral port's communications settings are being changed.	

Address	Bits	Name	Function	
A414	02	RS-422A Port Error Flags	Parity Error Flag	
	03		Framing Error Flag	
	04		Overrun Error Flag	
	05		Timeout Error Flag	
	08	RS-422A Port Communications Error Flag		Turns ON when a communications error has occurred at the RS-422A port.
	09	RS-422A Port Send Ready Flag (no-protocol mode)		Turns ON when the RS-422A port is ready to send data in no-protocol mode.
	10	RS-422A Port Reception Completed Flag (no-protocol mode)		Turns ON when the RS-422A port has completed the reception in no-protocol mode.
	11	RS-422A Port Reception Overflow Flag (no-protocol mode)		Turns ON when a data overflow occurred during reception through the RS-422A port in no-protocol mode.
	15	RS-422A Port Settings Changing Flag		Turns ON while the RS-422A port's communications settings are being changed.
A415	00 to 15	RS-422A Port Reception Counter (no-protocol mode)		Indicates (in binary) the number of bytes of data received when the RS-422A port is in no-protocol mode.
A500	14	Error Log Pointer Reset and Memory Not Held Flag OFF Bit		The error log pointer in A408 is reset to 0000 hex and Memory Not Held Flag (A404.14) is turned OFF when this bit is turned ON.
A502	00	RS-232C Port Restart Bit		Turn this bit ON to restart the RS-232C port. This bit is turned OFF automatically when the restart processing is completed.
	01	Peripheral Port Restart Bit		Turn this bit ON to restart the peripheral port. This bit is turned OFF automatically when the restart processing is completed.
	02	RS-422A Port Restart Bit		Turn this bit ON to restart the RS-422A port. This bit is turned OFF automatically when the restart processing is completed.
A507	00 to 15	Data Trace Period		Data will be traced using the period specified here when tracing each cycle is specified from the CX-Programmer. 0000 hex: Each cycle 0001 to 000F hex: Every 2 to 16 cycles
A508	09	Differentiate Monitor Completed Flag		Turns ON when the differentiate monitor condition has been established during execution of differentiation monitoring. (This flag will be turned OFF when differentiation monitoring starts.)
	11	Trace Trigger Monitor Flag		Turns ON when a trigger condition is established by the Trace Start Bit (A508.14). OFF when the next Data Trace is started by the Sampling Start bit (A508.15).
	12	Trace Completed Flag		Turns ON when sampling of a region of trace memory has been completed during execution of a Trace. Turns OFF when the next time the Sampling Start Bit (A508.15) is turned from OFF to ON.
	13	Trace Busy Flag		Turns ON when the Sampling Start Bit (A508.15) is turned from OFF to ON. Turns OFF when the trace is completed.
	14	Trace Start Bit		Turn this bit ON to establish the trigger condition. The offset indicated by the delay value (positive or negative) determines which data samples are valid.
	15	Sampling Start Bit		When a data trace is started by turning this bit from OFF to ON from the CX-Programmer, the FQM1 will begin storing data in Trace Memory by one of the three following methods: 1) Data is sampled at regular intervals (10 to 2,550 ms). 2) Data is sampled when TRSM(045) is executed in the program. 3) Data is sampled at the end of every cycle. The operation of A508.15 can be controlled only from the CX-Programmer.
A509	15	Constant Cycle Time Exceeded Error Clear Bit		Used to enable the constant cycle time function again after the constant cycle time has been exceeded.
A510 to A514	00 to 15	Macro Area Input Words		Before the subroutine specified in MCRO(099) is executed, the contents of the five words specified in the operand to be passed to the subroutine are stored here.
A515 to A519	00 to 15	Macro Area Output Words		After the subroutine specified in MCRO(099) has been executed, the results of the subroutine are transferred to these five words.

Address	Bits	Name	Function
A520	00 to 15	Interrupt Counter 0 Counter SV	Used for interrupt input 0 in counter mode. Sets the count value at which the interrupt task will start. Interrupt task 000 will start when interrupt counter 0 has counted this number of pulses. Setting range: 0000 to FFFF
A521	00 to 15	Interrupt Counter 1 Counter SV	Used for interrupt input 1 in counter mode. Sets the count value at which the interrupt task will start. Interrupt task 001 will start when interrupt counter 1 has counted this number of pulses. Setting range: 0000 to FFFF
A522	00 to 15	Interrupt Counter 2 Counter SV	Used for interrupt input 2 in counter mode. Sets the count value at which the interrupt task will start. Interrupt task 002 will start when interrupt counter 2 has counted this number of pulses. Setting range: 0000 to FFFF
A523	00 to 15	Interrupt Counter 3 Counter SV	Used for interrupt input 3 in counter mode. Sets the count value at which the interrupt task will start. Interrupt task 003 will start when interrupt counter 3 has counted this number of pulses. Setting range: 0000 to FFFF
A524	00 to 15	Interrupt Counter 0 Counter PV	These words contain the interrupt counter PVs for interrupt input 0 to 3 operating in counter mode. The counter PV starts decrementing from the counter SV. When the counter PV reaches the 0, the PV is automatically reset to the SV. Range: 0000 to FFFF
A525	00 to 15	Interrupt Counter 1 Counter PV	
A526	00 to 15	Interrupt Counter 2 Counter PV	
A527	00 to 15	Interrupt Counter 3 Counter PV	
A530	00	DM Write Request Bit (Coordinator Module to Motion Control Module)	
A530	01	DM Read Request Bit (Motion Control Module to Coordinator Module)	DM data transfer is executed from the Motion Control Module to Coordinator Module when this bit turns ON.
A531	00 to 15	Slot No. of Motion Control Module for DM Transfer	Specifies the slot number (in 4-digit hexadecimal) for the Motion Control Module with which DM data is to be transferred. 0001: Motion Control Module #1 0002: Motion Control Module #2 0003: Motion Control Module #3 0004: Motion Control Module #4
A532	00 to 15	DM Transfer Size (number of words)	Specifies the size, in number of words, of the DM data to be transferred. 0001 to 01F3 hex (1 to 499 words)
A533	00 to 15	First DM Transfer Source Word	Specifies the first address of the DM transfer source in the Coordinator Module or Motion Control Module. 0000 to 7FFF hex
A534	00 to 15	First DM Transfer Destination Word	Specifies the first address of the DM transfer destination in the Coordinator Module or Motion Control Module. 0000 to 7FFF hex
A535	14	Transfer Error Flag	Turns ON when a DM data transfer error occurs.
A535	15	Transfer Busy Flag	Turns ON during DM data transfer and turns OFF when the transfer has been completed.
A550	00 to 15	Analog Input PV	Contains the value input from the analog input port (using either the END refresh or immediate refresh) in 4-digit hexadecimal. The PV range depends on the input range: • 0 to 10 V: FE70 to 20D0 hex • 0 to 5 V or 1 to 5 V: FF38 to 1068 hex • -10 to 10 V: DDA0 to 2260 hex
A552	00	Analog Input Status	User Adjustment Completed OFF: Not adjusted ON: Adjustment completed
A552	07		Analog Sampling Started OFF: Not started ON: Started
A552	08		Factory Adjustment Data Error OFF: No Error ON: Error (Checked at power ON.)
A552	09		User Adjustment Data Error OFF: No Error ON: Error (Checked at power ON.)
A552	15		Analog Sampling Overlap OFF: Normal sampling ON: The next sampling operation occurred before the present sampling operation completed.



Address	Bits	Name	Function	
A559	00 to 15	Number of Analog Samples	Indicates the number of data samples actually input since sampling started.	
A560	00 to 15	Analog Output 1 Output Value	<p>When an END refresh is selected, the 4-digit hexadecimal value set here by the user is output from analog output port 1. When immediate refreshing is selected, the 4-digit hexadecimal value being output from analog output port 1 is stored here for monitoring. The output value range depends on the output range, as shown below.</p> <ul style="list-style-type: none"> <li>• 0 to 10 V, 0 to 5 V or 1 to 5 V: FF38 to 1068 hex</li> <li>• -10 to 10 V: EA84 to 157C hex</li> </ul> <p><b>Note</b></p> <ol style="list-style-type: none"> <li>1. Set the analog output method (END or immediate refreshing) with the System Setup's output method setting. A setting of 0 hex specifies an END refresh. This setting applies to both analog output 1 and 2.</li> <li>2. Specify the output range with the output 1 setting.</li> </ol>	
A561	00 to 15	Analog Output 2 Output Value	<p>This word has the same settings as the analog output 1 output value (A560), above. (When an END refresh is selected, set the value to output from analog output port 2. When an immediate refresh is selected, the output value is stored here for monitoring.)</p> <p><b>Note</b></p> <ol style="list-style-type: none"> <li>1. Set the analog output method (END or immediate refresh) with the System Setup's output method setting. A setting of 0 hex specifies an END refresh. This setting applies to both analog output 1 and 2.</li> <li>2. Specify the output range with the output 2 setting.</li> </ol>	
A562	00	Analog Output 1 Flags	User Adjustment Completed	Initial value is 0. Set to 1 if user performs offset/gain adjustment and Returns to factory default setting of 0 if adjustment value is cleared.
	04		Operating	ON: ON while the analog output is being changed by ACC(888). OFF: Turned OFF when target value is reached.
	08		Output SV Error	ON: ON when the output SV setting is outside of the allowed setting range. OFF: OFF when the output SV is within range.
	12		Factory Adjustment Value Error	ON: ON when the factory-set data stored in flash memory is invalid. OFF: OFF when the factory-set data stored in flash memory is normal.
	14		User Adjustment Value Error	ON: ON when the user-set adjustment value stored in flash memory is invalid. OFF: OFF when the user-set adjustment value stored in flash memory is normal.
A563	00	Analog Output 2 Flags	User Adjustment Completed	Same as for Analog Output 1 Flags.
	04		Operating	
	08		Output SV Error	
	12		Factory Adjustment Value Error	
	14		User Adjustment Value Error	
A564	00	Analog Output 1 Conversion Enable Bit	<p>ON: Enables D/A conversion (enables analog output). OFF: Disables D/A conversion (analog values output according to Output Stop Function specification in System Setup).</p> <p><b>Note</b> This bit is cleared when the Modules operating mode is changed between RUN or MONITOR mode and PROGRAM mode.</p>	
A565	00	Analog Output 2 Conversion Enable Bit	<p>ON: Enables D/A conversion (enables analog output). OFF: Disables D/A conversion (analog values output according to Output Stop Function specification in System Setup).</p> <p><b>Note</b> This bit is cleared when the Modules operating mode is changed between RUN or MONITOR mode and PROGRAM mode.</p>	

Address	Bits	Name		Function	
A570	00	Adjustment Mode Command Bits (Effective only when A575 is 5A5A hex.)	Adjustment Enable	Analog Input	OFF: Adjustment disabled. ON: Adjustment enabled.  When one of these bits is turned ON, the default value (offset or gain value) corresponding to the selected I/O signal range is transferred to Adjustment Mode Monitor Area (A572 and A573).
	02			Analog Output 1	
	03			Analog Output 2	
	07			Adjustment Mode Specifier	OFF: Offset adjustment ON: Gain adjustment
	12			Adjustment Value Increment	While this bit is ON, the offset or gain value will be incremented by one resolution unit each 0.5 ms.
	13			Adjustment Value Decrement	While this bit is ON, the offset or gain value will be decremented by one resolution unit each 0.5 ms.
	14			Adjustment Value Clear	OFF to ON: Clears the adjustment data to the factory defaults.
	15		Adjustment Value Set	OFF to ON: Reads the present value in the Adjustment Mode Monitor Area (A572 and A573) and saves this value to flash memory. This adjustment value will be used for the next normal mode operation.	
A571	00	Adjustment Mode Status	Adjustment Operation Error	ON when an operational error has been made, such as turning ON both the Analog Input and Analog Output 2 Adjustment Enable Bits at the same time.	
	15		Adjustment Mode Started	ON during adjustment mode operation (when A575 contains 5A5A hex).	
A572	00 to 15	Adjustment Mode Monitor (Effective only when A575 is 5A5A hex.)	Both Analog Input and Analog Outputs	Setting Offset Monitor	<ul style="list-style-type: none"> <li>• -10 to 10 V: FE0C to 01F4 hex</li> <li>• 0 to 10 V, 0 to 5 V, 1 to 5 V: FF38 to 00C8 hex</li> <li>• -10 to 10 V: 1194 to 157C hex</li> <li>• 0 to 10 V, 0 to 5 V, 1 to 5 V: 0ED8 to 1068 hex</li> </ul>
A573	00 to 15			Gain Value Monitor	
A574	00 to 15		Analog Inputs	Number of Average Value Samples in Adjustment Mode	
A575	00 to 15	Adjustment Mode Password		5A5A hex: Adjustment mode enabled. Other value: Adjustment mode disabled.	
A600	00 to 15	High-speed Counter 1 PV		Range: 8000 0000 to 7FFF FFFF	
A601	00 to 15			<b>Note</b> For a Linear Counter, high-speed counter overflows/underflows are checked when the PV is read (i.e., when Module internal I/O is refreshed).	
A602	00 to 15	High-speed Counter 2 PV			
A603	00 to 15				
A604 to A605	00 to 15	High-speed Counter 1	For following counter modes	PV of absolute number of rotations	Contains the number of rotations data (PV) read from the Encoder when the SEN signal is input to the Servo Driver. 8000 0000 to 7FFF FFFF hex
			<ul style="list-style-type: none"> <li>• Absolute linear (CW-)</li> <li>• Absolute circular</li> <li>• Absolute linear (CW+)</li> </ul>		
			For following counter modes	Monitor data	<ul style="list-style-type: none"> <li>• When monitoring counter movements (mode 1), contains the absolute value of the amount of change in the PV of the high-speed counter over the specified sampling time as a 8-digit hexadecimal value (0000 0000 to FFFF FFFF hex).</li> <li>• When monitoring the counter frequency (mode 2), contains the frequency of the high-speed counter calculated from the PV of the high-speed counter between 0 and 7A120 hex (0 and 500 kHz).</li> </ul>

Address	Bits	Name		Function	
A606 to A607	00 to 15	High-speed Counter 2	For following counter modes • Absolute linear (CW-) • Absolute circular • Absolute linear (CW+)	PV of absolute number of rotations	Same as for A604 and A605 for high-speed counter 1 except that measuring the high-speed counter frequency is not possible for high-speed counter 2.
			For following counter modes • Linear counter • Circular counter	Monitor data	
A608	00	High-speed counter 1 status	Target Comparison In-progress Flag		OFF: Target value comparison is not being performed for CTBL(882). <b>Note</b> This flag is always OFF for range comparison. ON: Target value comparison is being performed for CTBL(882). <b>Note</b> Target comparison is continued without interruption once it has been started (as opposed to range comparison), so this flag can be used to check whether target comparison is in progress.
	01		PV Overflow/Underflow Flag		OFF: There is no counter overflow or underflow in Linear Counter Mode. This flag will always be OFF in Circular Counter Mode. ON: There is a counter overflow or underflow in Linear Counter Mode. The counter PV will be fixed at the overflow or underflow limit. This flag will be cleared when the High-speed Counter Start Bit is turned OFF.
	03		Phase Z Input Reset Flag (ON for one cycle)		ON for one cycle when the counter PV is reset with the counter reset method set to a phase Z + software reset. <b>Note</b> This flag will turn ON for one cycle after the counter PV is reset if the phase Z signal (reset input) turns ON while the High-speed Counter Reset Bit (A610.01) is ON.
	04		Absolute No. of Rotations Read Error Flag		OFF: No error ON: Error
	05		Absolute No. of Rotations Read Completed Flag		OFF: Rotations being read or reading has not been executed. ON: Reading has been completed (Turned ON when serial reception of the number of rotations has been completed.)
	06		Measuring Flag (measurement mode 1 or 2) <b>Note</b> Valid when Counter Data Display in System Setup is set to Counter Movements (mode 1) or Frequency (mode 2).		OFF: Changes in the counter PV or the counter frequency is not being measured. ON: Changes in the counter PV or the counter frequency is being measured. In measurement mode 1, this flag will turn ON at the beginning of the sampling time after the Measurement Start Bit (A610.02) is turned ON.
	07		High-speed Counter Operating Flag		OFF: Counter is not operating. ON: Counter is operating.
	08		Count Latched Flag		OFF: Count has not been latched. ON: Latching the count has been completed for the latch input.
	12		Absolute Offset Preset Error Flag		OFF: No error occurred when saving the absolute offset. ON: An error occurred when saving the absolute offset.
A609	00	High-speed counter 2 status	Target Comparison In-progress Flag		Same as for high-speed counter 1.
	01		PV Overflow/Underflow Flag		
	03		Phase Z Input Reset Flag (ON for one cycle)		
	04		Absolute No. of Rotations Read Error Flag		
	05		Absolute No. of Rotations Read Completed Flag		
	06		Measuring Flag (measurement mode 1 or 2)		
	07		High-speed Counter Operating Flag		
	08		Count Latched Flag		
	12		Absolute Offset Preset Error Flag		

Address	Bits	Name	Function	
A610	00 01 02 03 04 05 06 07 08 09	High-speed counter 1 command bits	Start Bit	OFF: Stops counter operation. The counter PV will be maintained. ON: Starts counter operation. The counter PV will be reset.
			Reset Bit	OFF: If a software reset is set in the System Setup, the counter PV will not be reset when internal I/O is refreshed in the Motion Control Module. If a phase Z + software reset is set, disables the phase Z input. ON: If a software reset is set in the System Setup, resets the counter PV to 0 when internal I/O is refreshed in the Motion Control Module. If a phase Z + software reset is set, enables the phase Z input.
			Measurement Start Bit	OFF: Disables measuring changes in counter PV or the counter frequency. ON: Starts measuring changes in counter PV or the counter frequency. <b>Note</b> Measuring the high-speed counter frequency is possible only for high-speed counter 1. <b>Note</b> Valid when Counter Data Display in System Setup is set to Counter Movements (mode 1) or Frequency (mode 2).
			Measurement Direction Bit (measurement mode 2)	OFF: Forward (up) ON: Reverse (down) This bit specifies the up/down direction of the pulse input for frequency measurement. <b>Note</b> Always set this bit before turning ON the Measurement Start Bit.
			Range Comparison Results Clear Bit	OFF: Does not clear the execution results (A612) or output bit pattern (A613) from CTBL(882) execution for range comparison for the counter. ON: Clears the execution results (A612) or output bit pattern (A613) from CTBL(882) execution for range comparison for the counter.
			Absolute Offset Preset Bit	OFF: Does not preset the offset. OFF to ON: Stores the number of multi-turns read from the Servo Driver and the number of initial incremental pulses as an offset in the Absolute Offset value in the System Setup. When establishing the machine origin, the position from the absolute encoder origin is set as the Absolute Offset in the System Setup as the machine origin.
			Absolute Present Value Preset Bit	OFF: Disables the absolute present value preset. OFF to ON: Stores the Absolute PV in the counter 1 PV (A600 and A601). <b>Note</b> Refer to 7-7-6 <i>Absolute Present Value</i> for details on the absolute PV.
			Absolute Number of Rotations Read Bit	OFF: Disables reading the number of rotations data from the Servo Driver. OFF to ON: Outputs the SEN output to the Servo Driver and receives the number of rotations data on the phase A input.
			Latch Input 1 Enable Bit	OFF: Disables the external latch input 1 signal. ON: Enables the external latch input 1 signal.
			Latch Input 2 Enable Bit	OFF: Disables the external latch input 2 signal. ON: Enables the external latch input 2 signal.
A611	00 01 02 03 04 05 06 07 08 09	High-speed counter 2 command bits	Start Bit	Same as command bits for high-speed counter 1.
			Reset Bit	
			Measurement Start Bit	
			Reserved	
			Range Comparison Results Clear Bit	
			Absolute Offset Preset Bit	
			Absolute Present Value Preset Bit	
			Absolute Number of Rotations Read Bit	
			Latch Input 1 Enable Bit	
			Latch Input 2 Enable Bit	

Address	Bits	Name		Function
A612	00 to 15	High-speed counter 1 monitor data	Range Comparison Execution Results Flags	Contains the CTBL(882) execution results for range comparison. Bits 00 to 15 correspond to ranges 1 to 16. OFF: No match ON: Match
A613	00 to 15		Output Bit Pattern	Contains the output bit pattern when a match is found for CTBL(882) execution results for range comparison <b>Note</b> If more than one match is found, an OR of the output bit patterns with matches will be stored here.
A614	00 to 15	High-speed counter 2 monitor data	Range Comparison Results	Same as for high-speed counter 1 monitor data.
A615	00 to 15		Output Bit Pattern	
A620 to A621	00 to 15	Pulse Output 1 PV <b>Note</b> This item applies when the operation mode is relative pulse output, absolute pulse output in linear mode, absolute pulse output in circular mode, or electronic cam mode.		Contains the pulse output PV as an 8-digit hexadecimal number. Relative mode: 00000000 to FFFFFFFF hex Absolute linear mode: 80000000 to 7FFFFFFF hex Absolute circular mode: 00000000 to circular maximum count
		One-shot Pulse Output 1 ON Time <b>Note</b> This item applies when the operation mode is one-shot output mode.		Contains the time that the one-shot pulse output has been ON as an 8-digit hexadecimal number. 0000 0000 to 0000 270F (unit: set by STIM(980))
		Pulse Time Measurement 1 <b>Note</b> This item applies when the operation mode is time measurement mode using a pulse counter.		Contains the time measured by the pulse counter as an 8-digit hexadecimal number. 0000 0000 to FFFF FFFF hex (unit: set by STIM(980))
A622 to A623	00 to 15	Pulse Output 2 PV		Same as for Pulse Output 1 PV.
		One-shot Pulse Output 2 ON Time		Same as for One-shot Pulse Output 1 ON time.
		Pulse Time Measurement 2		Same as for Pulse Time Measurement 1.
A624	00	Pulse Output 1 Status	Pulse Output Completed Flag	OFF: Pulse output not completed (OFF during pulse output). ON: Pulse output completed (ON when pulse distribution has been completed).
	01		Pulse Output Set Flag	OFF: Pulse output amount not set by PULS(886). ON: Pulse output amount set by PULS(886).
	02		Target Frequency Not Reached Flag	OFF: Target speed has been reached during pulse output for PLS2(887). ON: Decelerated before reaching the target speed during pulse output for PLS2(887).
	03		Target Comparison Flag	OFF: Comparison stopped. ON: Comparison in progress.
	04		Independent Pulse Output Flag	OFF: Pulses not being output or being output continuously. ON: Pulses being output.
	05		PLS2 Positioning Flag	OFF: Not positioning. ON: Positioning in progress.
	06		Accelerating/Decelerating Flag	OFF: No output or constant-speed output. ON: Acceleration or deceleration in progress for ACC(888) or PLS2(887).
	07		Pulse Output Flag	OFF: Pulse output stopped. ON: Pulse output in progress.
A625	00	Pulse Output 2 Status	Pulse Output Completed Flag	Same as for Pulse Output 1 Status.
	01		Pulse Output Set Flag	
	02		Target Frequency Not Reached Flag	
	03		Target Comparison Flag	
	04		Independent Pulse Output Flag	
	05		PLS2 Positioning Flag	
	06		Accelerating/Decelerating Flag	
	07		Pulse Output Flag	

Address	Bits		Name	Function
A626	00	Pulse Output 1 Command Bits	PV Reset Bit	OFF: Pulse output 1 PV not reset. ON: Resets pulse output 1 PV.
	01		Range Comparison Results Clear Bit	OFF: Does not clear the execution results (A630) or output bit pattern (A631) from CTBL(882) execution for range comparison for the pulse output PV. ON: Clears the execution results (A630) or output bit pattern (A631) from CTBL(882) execution for range comparison for the pulse output PV.
A627	00	Pulse Output 2 Command Bits	PV Reset Bit	Same as for Pulse Output 1 Command Bits.
	01		Range Comparison Results Clear Bit	
A628	07	Pulse Output Control Bits (Apply to both pulse outputs 1 and 2.)	Speed Change Cycle Bit	OFF: Sets the speed change cycle to 2 ms during pulse output to ACC(888) or PLS2(887). ON: Sets the speed change cycle to 1 ms during pulse output to ACC(888) or PLS2(887).
	14		PLS2 Pulse Output Direction Priority Mode Bit	OFF: Sets Direction Priority Mode. In Direction Priority Mode, pulses are output only when the pulse output direction and the direction of the specified absolute position are the same. ON: Sets Absolute Position Priority Mode. In Absolute Position Priority Mode, pulses are always output in the direction of the specified absolute position.
A630	00 to 15	Pulse Output 1 Monitor Data	Range Comparison Results	Contains the CTBL(882) execution results for range comparison. Bits 00 to 15 correspond to ranges 1 to 16. OFF: No match ON: Match
A631	00 to 15		Output Bit Pattern	Contains the output bit pattern when a match is found for CTBL(882) execution results for range comparison <b>Note</b> If more than one match is found, an OR of the output bit patterns with matches will be stored here.
A632	00 to 15	Pulse Output 2 Monitor Data	Range Comparison Results	Same as for Pulse Output 1 Monitor Data.
A633	00 to 15		Output Bit Pattern	

## Detailed Explanations on the Auxiliary Area

### Error Log Area: A100 to A199

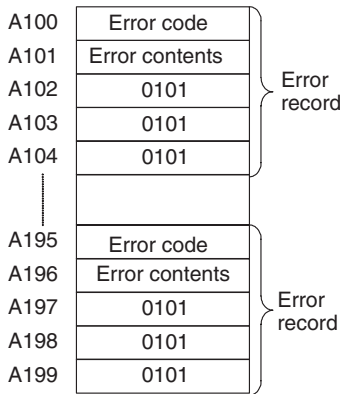

The following data would be generated in an error record if a memory error (error code 80F1) occurred with the error located in the System Setup (04 hex).

80 F1
00 04
01 01
01 01
01 01

The following data would be generated in an error record if an FALS error with FALS number 001 occurred

C1 01
00 00
01 01
01 01
01 01

## Error Codes and Error Flags

Classification	Error code	Meaning	Error flags
System-defined fatal errors	80F1	Memory error	A403
	80C0	I/O bus error	---
	80CE	No End Cover	---
	80CF	Sync bus error	---
	80E0	I/O setting error	---
	80F0	Program error	A405
	809F	Cycle time too long error	---
System-defined non-fatal errors	009B	System Setup setting error	A409
User-defined fatal errors	C101 to C2FF	FALS instruction executed (See note 1.)	---
User-defined non-fatal errors	4101 to 42FF	FAL instruction executed (See note 2.)	---

- Note**
- (1) Codes C101 to C2FF will be stored for FALS numbers 001 to 511.
  - (2) Codes 4101 to 42FF will be stored for FAL numbers 001 to 511.
  - (3) Only the contents of A405 is stored as the error flag contents for program errors.
  - (4) 0000 hex will be stored as the error flag contents.

## FQM1 Memory Addresses

FQM1 memory addresses are set in Index Registers (IR0 or IR1) to indirectly address I/O memory. Normally, FQM1 memory addresses are set into the Index Registers automatically when calling subroutines with JSB(982).

Some instructions, such as FIND MAXIMUM (MAX(182)) and FIND MINIMUM (MIN(183)), output the results of processing to an Index Register to indicate an FQM1 memory address.

There are also instructions for which Index Registers can be directly designated to use the FQM1 memory addresses stored in them by other instructions. These instructions include DOUBLE MOVE (MOVL(498)), some symbol comparison instructions (=L,<>L, <L, >L,<=L, and >=L), DOUBLE COMPARE (CMPL(060)), DOUBLE INCREMENT BINARY (++L(591)), DOUBLE DECREMENT BINARY (--L(593)), DOUBLE SIGNED BINARY ADD WITHOUT CARRY (+L(401)), and DOUBLE SIGNED BINARY SUBTRACT WITHOUT CARRY (-L(411)).

The FQM1 memory addresses all are continuous and the user must be aware of the order and boundaries of the memory areas. As reference, the FQM1 memory addresses are provided in the next page.

**Note** Directly setting FQM1 memory addresses in the program should be avoided whenever possible. If FQM1 memory addresses are set in the program, the program will be less compatible with new Modules for which changes have been made to the layout of the memory.

## Memory Configuration

There are two classifications of the RAM memory (with capacitor backup) in the FQM1.

**Parameter Areas:** These areas contain Coordinator Module system setting data, such as the System Setup. An illegal access error will occur if an attempt is made to access any of the parameter areas from an instruction in the user program.

**I/O Memory Areas:** These are the areas that can be specified as operands in the instructions in user programs.



## Memory Map

**Note** Do not access the areas indicated *Reserved for system*.

Classification	FQM1 memory addresses (hex)	User addresses	Area
Parameter areas	00000 to 0B0FF	---	System Setup Area Profile Area
I/O memory areas	0B100 to 0B1FF	---	Reserved for system.
	0B200 to 0B7FF	---	Reserved for system.
	0B800 to 0B801	TK0000 to TK0031	Task Flag Area
	0B802 to 0B83F	---	Reserved for system.
	0B840 to 0B9FF	A000 to A447	Read-only Auxiliary Area
	0BA00 to 0BACB	A448 to A649	Read/Write Auxiliary Area
	0BACA to 0BBFF	---	Reserved for system.
	0BC00 to 0BDFF	---	Reserved for system.
	0BE00 to 0BE0F	T0000 to T0255	Timer Completion Flags
	0BE10 to 0BEFF	---	Reserved for system.
	0BF00 to 0BF0F	C0000 to C0255	Counter Completion Flags
	0BF10 to 0BFFF	---	Reserved for system.
	0C000 to 0C0FF	CIO 0000 to CIO 0255	CIO Area
	0C100 to 0D7FF	---	Reserved for system.
	0D800 to 0D9FF	---	Reserved for system.
	0DA00 to 0DDFF	---	Reserved for system.
	0DE00 to 0DEFF	W000 to W255	Work Area
	0DF00 to 0DFFF	---	Reserved for system.
	0E000 to 0E0FF	T0000 to T0250	Timer PVs
	0E100 to 0EFFF	---	Reserved for system.
	0F000 to 0F0FF	C0000 to C0255	Counter PVs
	0F100 to 0FFFF	---	Reserved for system.
	10000 to 17FFF	D00000 to D32767	DM Area
18000 to FFFFF	---	Reserved for system.	

## FQM1 Instruction Execution Times and Number of Steps

The following table lists the execution times for all instructions that are available for the FQM1.

The total execution time of instructions within one whole user program is the process time for program execution when calculating the cycle time. (See note.)

**Note** User programs are allocated tasks that can be executed within cyclic tasks and interrupt tasks that satisfy interrupt conditions.

Execution times for most instructions differ depending on the conditions when the instruction is executed. The execution time can also vary when the execution condition is OFF.

The following table also lists the length of each instruction in the *Length (steps)* column. The number of steps required in the user program area for each of the instructions varies from 1 to 7 steps, depending upon the instruction and the operands used with it. The number of steps in a program is not the same as the number of instructions.

**Note** (1) Program capacity for the FQM1 is measured in steps. Basically speaking, 1 step is equivalent to 1 word.

Most instructions are supported in differentiated form (indicated with  $\uparrow$ ,  $\downarrow$ , @, and %). Specifying differentiation will increase the execution times by the following amounts.

Symbol	$\mu\text{s}$
$\uparrow$ or $\downarrow$	+0.5
@ or %	+0.5

(2) Use the following time as a guideline when instructions are not executed.  
Approx. 0.2 to 0.5  $\mu\text{s}$

### Sequence Input Instructions

Instruction	Mnemonic	Code	Length (steps) (See note.)	ON execution time ( $\mu\text{s}$ )	Hardware implementation	Conditions
LOAD	LD	---	1	0.10	Yes	---
LOAD NOT	LD NOT	---	1	0.10	Yes	---
AND	AND	---	1	0.10	Yes	---
AND NOT	AND NOT	---	1	0.10	Yes	---
OR	OR	---	1	0.10	Yes	---
OR NOT	OR NOT	---	1	0.10	Yes	---
AND LOAD	AND LD	---	1	0.05	Yes	---
OR LOAD	OR LD	---	1	0.05	Yes	---

**Note** When a double-length operand is used, add 1 to the value shown in the length column in the above table.

### Sequence Output Instructions

Instruction	Mnemonic	Code	Length (steps) (See note.)	ON execution time ( $\mu\text{s}$ )	Hardware implementation	Conditions
OUTPUT	OUT	---	1	0.35	Yes	---
OUTPUT NOT	OUT NOT	---	1	0.35	Yes	---
KEEP	KEEP	011	1	0.40	Yes	---
DIFFERENTIATE UP	DIFU	013	2	0.50	Yes	---
DIFFERENTIATE DOWN	DIFD	014	2	0.50	Yes	---
SET	SET	---	1	0.30	Yes	---
RESET	RSET	---	1	0.30	Yes	---

**Note** When a double-length operand is used, add 1 to the value shown in the length column in the above table.

**Sequence Control Instructions**

Instruction	Mnemonic	Code	Length (steps) (See note.)	ON execution time (μs)	Hardware implementation	Conditions
END	END	001	1	7.0	Yes	---
NO OPERATION	NOP	000	1	0.05	Yes	---
INTERLOCK	IL	002	1	0.15	Yes	---
INTERLOCK CLEAR	ILC	003	1	0.15	Yes	---
JUMP	JMP	004	2	0.95	Yes	---
JUMP END	JME	005	2	---	---	---

**Note** When a double-length operand is used, add 1 to the value shown in the length column in the above table.

**Timer and Counter Instructions**

Instruction	Mnemonic	Code	Length (steps) (See note.)	ON execution time (μs)	Hardware implementation	Conditions
TIMER	TIM	---	3	1.30	Yes	---
COUNTER	CNT	---	3	1.30	Yes	---
HIGH-SPEED TIMER	TIMH	015	3	1.80	Yes	---
ONE-MS TIMER	TMHH	540	3	1.75	Yes	---
REVERSIBLE COUNTER	CNTR	012	3	24.8	---	---

**Note** When a double-length operand is used, add 1 to the value shown in the length column in the above table.

**Comparison Instructions**

Instruction	Mnemonic	Code	Length (steps) (See note.)	ON execution time (μs)	Hardware implementation	Conditions
Input Comparison Instructions (unsigned)	LD, AND, OR +=	300	4	0.35	Yes	---
	LD, AND, OR + <>	305				
	LD, AND, OR + <	310				
	LD, AND, OR + <=	315				
	LD, AND, OR + >	320				
	LD, AND, OR + >=	325				
Input Comparison Instructions (double, unsigned)	LD, AND, OR +=+L	301	4	0.35	Yes	---
	LD, AND, OR +<>+L	306				
	LD, AND, OR +<+L	311				
	LD, AND, OR +<=+L	316				
	LD, AND, OR +>+L	321				
	LD, AND, OR +>=+L	326				
Input Comparison Instructions (signed)	LD, AND, OR +=+S	302	4	0.35	Yes	---
	LD, AND, OR +<>+S	307				
	LD, AND, OR +<+S	312				
	LD, AND, OR +<=+S	317				
	LD, AND, OR +>+S	322				
	LD, AND, OR +>=+S	327				

Instruction	Mnemonic	Code	Length (steps) (See note.)	ON execution time (μs)	Hardware implementation	Conditions
Input Comparison Instructions (double, signed)	LD, AND, OR +=+SL	303	4	0.35	Yes	---
	LD, AND, OR +<>+SL	308				
	LD, AND, OR +<+SL	313				
	LD, AND, OR +<=+SL	318				
	LD, AND, OR +>+SL	323				
	LD, AND, OR +>=+SL	328				
COMPARE	CMP	020	3	0.10	Yes	---
DOUBLE COMPARE	CMPL	060	3	0.50	Yes	---
SIGNED BINARY COMPARE	CPS	114	3	0.30	Yes	---
DOUBLE SIGNED BINARY COMPARE	CPSL	115	3	0.50	Yes	---
TABLE COMPARE	TCMP	085	4	30.3	---	---
MULTIPLE COMPARE	MCMP	019	4	47.5	---	---
UNSIGNED BLOCK COMPARE	BCMP	068	4	50.3	---	---
EXPANDED BLOCK COMPARE	BCMP2	502	4	15.3	---	Number of data words: 1
				689.1	---	Number of data words: 255
AREA RANGE COMPARE	ZCP	088	3	11.6	---	---
DOUBLE AREA RANGE COMPARE	ZCPL	116	3	11.4	---	---

**Note** When a double-length operand is used, add 1 to the value shown in the length column in the above table.

**Data Movement Instructions**

Instruction	Mnemonic	Code	Length (steps) (See note.)	ON execution time (μs)	Hardware implementation	Conditions
MOVE	MOV	021	3	0.30	Yes	---
DOUBLE MOVE	MOVL	498	3	0.60	Yes	---
MOVE NOT	MVN	022	3	0.35	Yes	---
DOUBLE MOVE NOT	MVNL	499	3	0.60	Yes	---
MOVE BIT	MOVB	082	4	0.50	Yes	---
MOVE DIGIT	MOVD	083	4	0.50	Yes	---
BLOCK TRANSFER	XFER	070	4	0.8	Yes	Transferring 1 word
				650.2	Yes	Transferring 1,000 words
BLOCK SET	BSET	071	4	0.55	Yes	Setting 1 word
				400.2	Yes	Setting 1,000 words
DATA EXCHANGE	XCHG	073	3	0.80	Yes	---
SINGLE WORD DISTRIBUTE	DIST	080	4	10.5	---	---
DATA COLLECT	COLL	081	4	10.5	---	---

**Note** When a double-length operand is used, add 1 to the value shown in the length column in the above table.

**Data Shift Instructions**

Instruction	Mnemonic	Code	Length (steps) (See note.)	ON execution time ( $\mu$ s)	Hardware implementation	Conditions
SHIFT REGISTER	SFT	010	3	12.4	---	Shifting 1 word
				368.1	---	Shifting 1,000 words
REVERSIBLE SHIFT REGISTER	SFTR	084	4	14.0	---	Shifting 1 word
				1.44 ms	---	Shifting 1,000 words
ASYNCHRONOUS SHIFT REGISTER	ASFT	017	4	13.9	---	Shifting 1 word
				3.915 ms	---	Shifting 1,000 words
WORD SHIFT	WSFT	016	4	9.7	---	Shifting 1 word
				728.1	---	Shifting 1,000 words
ARITHMETIC SHIFT LEFT	ASL	025	2	0.45	Yes	---
DOUBLE SHIFT LEFT	ASLL	570	2	0.80	Yes	---
ARITHMETIC SHIFT RIGHT	ASR	026	2	0.45	Yes	---
DOUBLE SHIFT RIGHT	ASRL	571	2	0.80	Yes	---
ROTATE LEFT	ROL	027	2	0.45	Yes	---
DOUBLE ROTATE LEFT	ROLL	572	2	0.80	Yes	---
ROTATE LEFT WITHOUT CARRY	RLNC	574	2	0.45	Yes	---
DOUBLE ROTATE LEFT WITHOUT CARRY	RLNL	576	2	0.80	Yes	---
ROTATE RIGHT	ROR	028	2	0.45	Yes	---
DOUBLE ROTATE RIGHT	RORL	573	2	0.80	Yes	---
ROTATE RIGHT WITHOUT CARRY	RRNC	575	2	0.45	Yes	---
DOUBLE ROTATE RIGHT WITHOUT CARRY	RRNL	577	2	0.80	Yes	---
ONE DIGIT SHIFT LEFT	SLD	074	3	10.1	---	Shifting 1 word
				1.208 ms	---	Shifting 1,000 words
ONE DIGIT SHIFT RIGHT	SRD	075	3	11.7	---	Shifting 1 word
				1.775 ms	---	Shifting 1,000 words

**Note** When a double-length operand is used, add 1 to the value shown in the length column in the above table.

**Increment/Decrement Instructions**

Instruction	Mnemonic	Code	Length (steps) (See note.)	ON execution time ( $\mu$ s)	Hardware implementation	Conditions
INCREMENT BINARY	++	590	2	0.45	Yes	---
DOUBLE INCREMENT BINARY	++L	591	2	0.80	Yes	---
DECREMENT BINARY	--	592	2	0.45	Yes	---
DOUBLE DECREMENT BINARY	--L	593	2	0.80	Yes	---
INCREMENT BCD	++B	594	2	12.1	---	---
DOUBLE INCREMENT BCD	++BL	595	2	9.37	---	---
DECREMENT BCD	--B	596	2	11.5	---	---
DOUBLE DECREMENT BCD	--BL	597	2	9.3	---	---

**Note** When a double-length operand is used, add 1 to the value shown in the length column in the above table.

### Symbol Math Instructions

Instruction	Mnemonic	Code	Length (steps) (See note.)	ON execution time ( $\mu$ s)	Hardware implementation	Conditions
SIGNED BINARY ADD WITHOUT CARRY	+	400	4	0.30	Yes	---
DOUBLE SIGNED BINARY ADD WITHOUT CARRY	+L	401	4	0.60	Yes	---
SIGNED BINARY ADD WITH CARRY	+C	402	4	0.40	Yes	---
DOUBLE SIGNED BINARY ADD WITH CARRY	+CL	403	4	0.60	Yes	---
BCD ADD WITHOUT CARRY	+B	404	4	16.3	---	---
DOUBLE BCD ADD WITHOUT CARRY	+BL	405	4	22.9	---	---
BCD ADD WITH CARRY	+BC	406	4	17.2	---	---
DOUBLE BCD ADD WITH CARRY	+BCL	407	4	24.1	---	---
SIGNED BINARY SUBTRACT WITHOUT CARRY	-	410	4	0.3	Yes	---
DOUBLE SIGNED BINARY SUBTRACT WITHOUT CARRY	-L	411	4	0.60	Yes	---
SIGNED BINARY SUBTRACT WITH CARRY	-C	412	4	0.40	Yes	---
DOUBLE SIGNED BINARY SUBTRACT WITH CARRY	-CL	413	4	0.60	Yes	---
BCD SUBTRACT WITHOUT CARRY	-B	414	4	16.3	---	---
DOUBLE BCD SUBTRACT WITHOUT CARRY	-BL	415	4	23.1	---	---
BCD SUBTRACT WITH CARRY	-BC	416	4	18.1	---	---
DOUBLE BCD SUBTRACT WITH CARRY	-BCL	417	4	24.2	---	---
SIGNED BINARY MULTIPLY	*	420	4	0.65	Yes	---
DOUBLE SIGNED BINARY MULTIPLY	*L	421	4	12.8	---	---
UNSIGNED BINARY MULTIPLY	*U	422	4	0.75	Yes	---
DOUBLE UNSIGNED BINARY MULTIPLY	*UL	423	4	12.4	---	---
BCD MULTIPLY	*B	424	4	16.9	---	---
DOUBLE BCD MULTIPLY	*BL	425	4	34.7	---	---
SIGNED BINARY DIVIDE	/	430	4	0.70	Yes	---
DOUBLE SIGNED BINARY DIVIDE	/L	431	4	11.9	---	---
UNSIGNED BINARY DIVIDE	/U	432	4	0.8	Yes	---
DOUBLE UNSIGNED BINARY DIVIDE	/UL	433	4	11.9	---	---

Instruction	Mnemonic	Code	Length (steps) (See note.)	ON execution time (μs)	Hardware implementation	Conditions
BCD DIVIDE	/B	434	4	18.3	---	---
DOUBLE BCD DIVIDE	/BL	435	4	26.7	---	---

**Note** When a double-length operand is used, add 1 to the value shown in the length column in the above table.

**Conversion Instructions**

Instruction	Mnemonic	Code	Length (steps) (See note.)	ON execution time (μs)	Hardware implementation	Conditions
BCD-TO-BINARY	BIN	023	3	0.40	Yes	---
DOUBLE BCD-TO-DOUBLE BINARY	BINL	058	3	7.4	---	---
BINARY-TO-BCD	BCD	024	3	8.0	---	---
DOUBLE BINARY-TO-DOUBLE BCD	BCDL	059	3	8.0	---	---
2'S COMPLEMENT	NEG	160	3	0.35	Yes	---
DOUBLE 2'S COMPLEMENT	NEGL	161	3	0.60	Yes	---
ASCII CONVERT	ASC	086	4	11.8	---	Converting 1 digit into ASCII
				18.1	---	Converting 4 digits into ASCII
ASCII TO HEX	HEX	162	4	12.2	---	Converting 1 digit

**Note** When a double-length operand is used, add 1 to the value shown in the length column in the above table.

**Logic Instructions**

Instruction	Mnemonic	Code	Length (steps) (See note.)	ON execution time (μs)	Hardware implementation	Conditions
LOGICAL AND	ANDW	034	4	0.30	Yes	---
DOUBLE LOGICAL AND	ANDL	610	4	0.60	Yes	---
LOGICAL OR	ORW	035	4	0.45	Yes	---
DOUBLE LOGICAL OR	ORWL	611	4	0.60	Yes	---
EXCLUSIVE OR	XORW	036	4	0.45	Yes	---
DOUBLE EXCLUSIVE OR	XORL	612	4	0.60	Yes	---
EXCLUSIVE NOR	XNRW	037	4	0.45	Yes	---
DOUBLE EXCLUSIVE NOR	XNRL	613	4	0.60	Yes	---
COMPLEMENT	COM	029	2	0.45	Yes	---
DOUBLE COMPLEMENT	COML	614	2	0.80	Yes	---

**Note** When a double-length operand is used, add 1 to the value shown in the length column in the above table.

**Special Math Instructions**

Instruction	Mnemonic	Code	Length (steps) (See note.)	ON execution time (μs)	Hardware implementation	Conditions
ARITHMETIC PROCESS	APR	069	4	24.3	---	Linear approximation specification, normal
				12.1	---	Linear approximation table transfer, 1 word
				126.1	---	Linear approximation table transfer, 128 words
				241.3	---	Linear approximation table transfer, 256 words
				21.5	---	Linear approximation buffer specification, 256 words, beginning
				186.9	---	Linear approximation buffer specification, 256 words, end
				104.5	---	Linear approximation buffer specification, 128 words, end
BIT COUNTER	BCNT	067	4	0.65	Yes	Counting 1 word
VIRTUAL AXIS	AXIS	981	4	47.9	---	Relative mode
				48.1	---	Absolute mode
				8.3	---	Stopping processing

**Note** When a double-length operand is used, add 1 to the value shown in the length column in the above table.

**Floating-point Math Instructions**

Instruction	Mnemonic	Code	Length (steps) (See note.)	ON execution time (μs)	Hardware implementation	Conditions
FLOATING TO 32-BIT	FIXL	451	3	7.4	---	---
32-BIT TO FLOATING	FLTL	453	3	7.0	---	---
FLOATING-POINT ADD	+F	454	4	11.4	---	---
FLOATING-POINT SUBTRACT	-F	455	4	11.0	---	---
FLOATING-POINT DIVIDE	/F	457	4	11.1	---	---
FLOATING-POINT MULTIPLY	*F	456	4	11.0	---	---
DEGREES TO RADIANS	RAD	458	3	9.7	---	---
RADIANS TO DEGREES	DEG	459	3	9.4	---	---
SINE	SIN	460	3	15.8	---	---
COSINE	COS	461	3	15.5	---	---
TANGENT	TAN	462	3	17.5	---	---
ARC SINE	ASIN	463	3	42.7	---	---
ARC COSINE	ACOS	464	3	42.5	---	---
ARC TANGENT	ATAN	465	3	21.3	---	---
SQUARE ROOT	SQRT	466	3	25.5	---	---
EXPONENT	EXP	467	3	18.1	---	---
LOGARITHM	LOG	468	3	16.1	---	---
EXPONENTIAL POWER	PWR	840	4	31.5	---	---



Instruction	Mnemonic	Code	Length (steps) (See note.)	ON execution time (μs)	Hardware implementation	Conditions
Floating Symbol Comparison	LD, AND, OR +=F	329	3	8.9	---	---
	LD, AND, OR +<>F	330				
	LD, AND, OR +<F	331				
	LD, AND, OR +<=F	332				
	LD, AND, OR +>F	333				
	LD, AND, OR +>=F	334				

**Note** When a double-length operand is used, add 1 to the value shown in the length column in the above table.

**Table Data Processing Instructions**

Instruction	Mnemonic	Code	Length (steps) (See note.)	ON execution time (μs)	Hardware implementation	Conditions
FIND MAXIMUM	MAX	182	4	13.0	---	Searching for 1 word
				1.41 ms	---	Searching for 1,000 words
FIND MINIMUM	MIN	183	4	12.8	---	Searching for 1 word
				1.412 ms	---	Searching for 1,000 words

**Note** When a double-length operand is used, add 1 to the value shown in the length column in the above table.

**Data Control Instructions**

Instruction	Mnemonic	Code	Length (steps) (See note.)	ON execution time (μs)	Hardware implementation	Conditions
SCALING	SCL	194	4	22.7	---	---
SCALING 2	SCL2	486	4	21.8	---	---
SCALING 3	SCL3	487	4	26.1	---	---
AVERAGE	AVG	195	4	27.9	---	Average of an operation
				27.9	---	Average of 64 operations

**Note** When a double-length operand is used, add 1 to the value shown in the length column in the above table.

**Subroutine Instructions**

Instruction	Mnemonic	Code	Length (steps) (See note.)	ON execution time (μs)	Hardware implementation	Conditions
SUBROUTINE CALL	SBS	091	2	25.5	Yes	---
SUBROUTINE ENTRY	SBN	092	2	---	---	---
SUBROUTINE RETURN	RET	093	1	21.9	Yes	---
MACRO	MCRO	099	4	47.4	---	---
JUMP TO SUBROUTINE	JSB	982	4	34.9	---	---

**Note** When a double-length operand is used, add 1 to the value shown in the length column in the above table.

**Interrupt Control Instructions**

Instruction	Mnemonic	Code	Length (steps) (See note.)	ON execution time (μs)	Hardware implementation	Conditions
SET INTERRUPT MASK	MSKS	690	3	7.6	---	---
READ INTERRUPT MASK	MSKR	692	3	5.2	---	---
CLEAR INTERRUPT	CLI	691	3	7.2	---	---
DISABLE INTERRUPTS	DI	693	1	5.3	---	---
ENABLE INTERRUPTS	EI	694	1	5.6	---	---
INTERVAL TIMER	STIM	980	4	9.5	---	One-shot timer
				11.0	---	One-shot pulse output
				9.5	---	Scheduled interrupt
				10.8	---	Reading timer PV
				7.4	---	Stopping timer
				17.8	---	Starting pulse counting
				14.7	---	Stopping pulse counting

**Note** When a double-length operand is used, add 1 to the value shown in the length column in the above table.

**High-speed Counter and Pulse Output Instructions**

Instruction	Mnemonic	Code	Length (steps) (See note.)	ON execution time (μs)	Hardware implementation	Conditions
MODE CONTROL	INI	880	4	16.7	---	Starting high-speed counter comparison
				12.7	---	Stopping high-speed counter comparison
				13.3	---	Changing pulse output PV
				10.9	---	Changing high-speed counter circular value
				16.7	---	Starting pulse output comparison
				12.6	---	Stopping pulse output comparison
				14.9	---	Changing pulse output PV
				13.1	---	Changing pulse output circular value
				12.5	---	Stopping pulse output
				10.1	---	Stopping sampling counter comparison
				14.5	---	Changing sampling counter PV
HIGH-SPEED COUNTER PV READ	PRV	881	4	13.5	---	Reading pulse output PV
				15.1	---	Reading high-speed counter PV
				50.8	---	Reading analog input PV
				14.3	---	Reading high-speed counter travel distance
				12.1	---	Reading high-speed counter latched value

Instruction	Mnemonic	Code	Length (steps) (See note.)	ON execution time (μs)	Hardware implementation	Conditions
COMPARISON TABLE LOAD	CTBL	882	4	36.5	---	Registering target value table and starting comparison for 1 target value
				259.6	---	Registering target value table and starting comparison for 48 target values
				22.1	---	Executing range comparison for 1 range
				113.7	---	Executing range comparison for 16 ranges
				22.1	---	Only registering target value table for 1 target value
				240.1	---	Only registering target value table for 48 target values
				20.9	---	Registering a sampling counter target value table and starting comparison
				42.8	---	Analog output
SPEED OUTPUT	SPED	885	4	23.7	---	Continuous mode
				32.7	---	Independent mode
				42.9	---	Analog output
SET PULSES	PULS	886	4	15.9	---	Setting pulse output in relative mode
				16.1	---	Setting pulse output in absolute mode
				31.5	---	Absolute output mode (electronic cam)
PULSE OUTPUT	PLS2	887	4	53.5	---	---
ACCELERATION CONTROL	ACC	888	4	42.5	---	Continuous mode
				44.1	---	Independent mode
				18.7	---	Analog output

**Step Instructions**

Instruction	Mnemonic	Code	Length (steps) (See note.)	ON execution time (μs)	Hardware implementation	Conditions
STEP DEFINE	STEP	008	2	24.3	---	Step control bit ON
				13.0	---	Step control bit OFF
STEP START	SNXT	009	2	9.1	---	---

**Note** When a double-length operand is used, add 1 to the value shown in the length column in the above table.

**I/O Refresh Instruction**

Instruction	Mnemonic	Code	Length (steps) (See note.)	ON execution time (μs)	Hardware implementation	Conditions
I/O REFRESH	IORF	097	3	7.7	---	Refreshing 1 input word
				7.6	---	Refreshing 1 output word

**Note** When a double-length operand is used, add 1 to the value shown in the length column in the above table.

**Serial Communications Instructions**

Instruction	Mnemonic	Code	Length (steps) (See note.)	ON execution time ( $\mu$ s)	Hardware implementation	Conditions
TRANSMIT	TXD	236	4	24.1	---	Sending 1 byte
				342.6	---	Sending 256 bytes
RECEIVE	RXD	235	4	36.2	---	Storing 1 byte
				348.9	---	Storing 256 bytes
CHANGE SERIAL PORT SETUP	STUP	237	3	441.1	---	---

**Note** When a double-length operand is used, add 1 to the value shown in the length column in the above table.

**Debugging Instructions**

Instruction	Mnemonic	Code	Length (steps) (See note.)	ON execution time ( $\mu$ s)	Hardware implementation	Conditions
TRACE MEMORY SAMPLING	TRSM	045	1	34.6	---	Sampling 1 bit and 0 words
				148.3	---	Sampling 31 bits and 6 words

**Note** When a double-length operand is used, add 1 to the value shown in the length column in the above table.

**Failure Diagnosis Instructions**

Instruction	Mnemonic	Code	Length (steps) (See note.)	ON execution time ( $\mu$ s)	Hardware implementation	Conditions
FAILURE ALARM	FAL	006	3	157.1	---	Recording errors
				56.0	---	Deleting errors (in order of priority)
				457.0	---	Deleting errors (all errors)
				53.6	---	Deleting errors (individually)
SEVERE FAILURE ALARM	FALS	007	3	---	---	---

**Note** When a double-length operand is used, add 1 to the value shown in the length column in the above table.

**Other Instructions**

Instruction	Mnemonic	Code	Length (steps) (See note.)	ON execution time ( $\mu$ s)	Hardware implementation	Conditions
SET CARRY	STC	040	1	0.15	Yes	---
CLEAR CARRY	CLC	041	1	0.15	Yes	---

**Note** When a double-length operand is used, add 1 to the value shown in the length column in the above table.

**Block Programming Instructions**

Instruction	Mnemonic	Code	Length (steps) (See note.)	ON execution time ( $\mu$ s)	Hardware implementation	Conditions
BLOCK PROGRAM BEGIN	BPRG	096	2	20.3	---	---
BLOCK PROGRAM END	BEND	801	1	17.2	---	---

Instruction	Mnemonic	Code	Length (steps) (See note.)	ON execution time (μs)		Conditions
Branching	IF (input condition)	802	1	6.8	Yes	IF true
				12.2		IF false
Branching	IF (relay number)	802	2	11.0	Yes	IF true
				16.5		IF false
Branching (NOT)	IF NOT (relay number)	802	2	11.5	Yes	IF true
				16.8		IF false
Branching	ELSE	803	1	11.4	Yes	IF true
				13.4		IF false
Branching	IEND	804	1	13.5	Yes	IF true
				7.0		IF false

**Note** When a double-length operand is used, add 1 to the value shown in the length column in the above table.



# Index

## A

- A/D conversion value, 222
- absolute encoder
  - absolute circular counter, 202
  - absolute linear counter, 202
  - absolute offset preset, 203
  - absolute present value, 202
  - absolute PV preset, 203
  - output data
    - acquisition, 207
    - format, 200
- Absolute No. of Rotations Read Completed Flag, 338, 339, 353
- Absolute No. of Rotations Read Error Flag, 338, 339, 353
- Absolute Offset Preset Error Flag, 338, 339, 353
- absolute position priority mode, 183
- absolute positioning (electronic cam control), 191
- ACC(888) instruction, 182, 190
  - and analog outputs, 229
  - pulse outputs, 170
  - setting speed-change cycle, 183
- Accelerating/Decelerating Flag, 355
- acceleration
  - trapezoidal, 193
- acceleration rate, 182
- Access Error Flag, 306
- addresses
  - memory map, 358
- addressing
  - BCD mode, 305
  - binary mode, 305
  - indirect addresses, 271
  - memory addresses, 269
  - operands, 270
- alarms
  - user-programmed alarms, 121
- Always OFF Flag, 306
- Always ON Flag, 306
- analog I/O
  - high-speed control, 26
- analog inputs, 215
  - Auxiliary Area, 219
  - connections, 74
  - specifications, 217
  - System Setup, 218
- Analog Offset/Gain Error Flag, 343, 348
- Analog Output 1 Flags, 335, 351
- Analog Output 2 Flags, 335, 351
- analog outputs
  - applicable instructions, 228
  - application examples, 230
  - Auxiliary Area, 219
  - connections, 74
  - details, 225
  - END refreshing, 226
  - functions, 227
  - immediate refreshing, 226
  - instructions, 228
  - number of, 226
  - procedure, 229
  - refresh methods, 226
  - signal ranges, 226
  - specifications, 226
  - System Setup, 218
  - used with ACC(888), 229
  - values, 226
- ASync Mode, 96, 104
- automatic backup
  - using flash memory, 119
- Auxiliary Area
  - allocations
    - for built-in inputs, 341
    - for Coordinator Modules and Motion Control Modules, 342
    - in address order, 347
    - Motion Control Modules, 327
    - related to DM data transfer, 344
    - related to instructions, 345
  - analog I/O, 219
  - Constant Cycle Time Exceeded Error Clear Bit, 115
  - Cycle Time PV, 116
  - detailed explanations, 357
  - DM Read Request Bit, 113
  - DM Transfer Size, 113
  - DM Write Request Bit, 113
  - First DM Transfer Destination Word, 113
  - First DM Transfer Source Word, 113
  - Maximum Cycle Time, 116
  - overview, 302
  - Slot No. of Motion Control Module for DM Transfer, 113
- AXIS instruction, 213
  - application example, 215

## B

- baud rate, 311, 316
  - detection, 35

- RS-232C port, 66, 134
  - serial data, 200
- BCD data, 274
- BCD-mode addressing, 305
- binary-mode addressing, 305
- block programs, 268, 284, 285
  - instruction execution times, 370

## C

- cables, 233
- Carry (CY) Flag, 268, 283, 306
- CIO Area, 300
  - Cyclic Refresh Bit Area, 300
  - I/O Bit Area, 300
  - Serial PLC Link Bit Area, 301
  - Synchronous Data Link Bit Area, 301
  - Work Areas, 301
- Circular Counter, 154, 202
- circular mode, 182
- CLC(041) instruction, 306
- Clock Pulses, 307
- communications
  - instruction execution times, 370
  - no-protocol, 10, 13
  - protocol support, 9
  - protocols, 9
  - See also* serial communications
- comparison instructions
  - execution times, 361, 362
- Completion Flags
  - reset timing, 304
- Condition Flags, 279, 305
  - list, 306
- connecting cables
  - list, 83
- connections
  - analog inputs, 74
  - analog outputs, 74
  - Host Link, 64
  - MIL connectors, 74
  - peripheral bus (Toolbus), 65
  - personal computers, 64
  - pulse inputs, 71
  - pulse outputs, 73
  - Servo Drivers, 70
  - wire size, 75
- connectors, 65
  - connections, 74
  - pin arrangement
    - Coordinator Modules, 67
    - Motion Control Modules, 68
- Connector-Terminal Block Conversion Units, 75
- constant cycle time, 19, 114
  - Sync Mode, 115
- Constant Cycle Time Exceeded Error Clear Bit, 115, 117
- Constant Cycle Time Exceeded Flag, 115, 344, 348
- constants
  - operands, 272
- control panels
  - installation, 53
- cooling
  - fan, 50
- Coordinator Module Fatal Error Flag, 248, 343, 347
- Coordinator Module WDT Error Flag, 248, 343, 347
- Coordinator Modules, 92
  - built-in I/O allocations, 346
  - connector pin arrangement, 67
  - connectors, 65
  - constant cycle time, 115
  - current consumption, 45
  - Cyclic Refresh Area, 107
  - data exchange with Motion Control Modules, 105
  - dimensions, 43
  - flash memory, 93
  - I/O memory, 92, 298
  - I/O response time, 291
  - indicators, 34
  - models, 32
  - nomenclature, 34
  - operation, 93
  - overview, 5, 7
  - System Setup, 93, 111, 309
  - troubleshooting, 254
  - user program, 92
- Count Latched Flag, 338, 339, 353
- Counter Area, 304
- Counter Completion Flags, 359
- counter mode, 143, 204
  - procedure, 144
- counters
  - execution times, 361
  - operations, 154, 201
  - reset method, 204
- CPU errors, 244
- CPU standby, 244
- crimp terminals, 61
- CTBL(882) instruction, 152, 223



- current consumption, 45
- CX-Programmer, 92, 95
  - Analog Input/Output Tab Page, 323
  - connecting cables, 232, 236
  - connections, 233
    - methods, 235
  - Cycle Time Settings, 310
  - Cycle Time Tab Page, 319
  - models, 32
  - Module Settings Tab Page, 319
  - Other Tab Page, 319
  - overview, 8, 232
  - Peripheral Port Settings, 311
  - Peripheral Port Settings for Host Link, 311
  - Peripheral Port Settings for NT Link, 312
  - Peripheral Port Settings for Peripheral Bus (ToolBus), 312
  - Peripheral Service Time Settings, 318
  - Pulse Input Tab Page, 320, 322
  - Pulse Output Tab Page, 321
  - RS-232 Port Settings for No-protocol Communications (RS-232C), 315
  - RS-232C Port Settings for Host Link, 313
  - RS-232C Port Settings for NT Link, 314
  - RS-232C Port Settings for Peripheral Bus (ToolBus), 314
  - RS-232C Port Settings for PLC Link (PC Link (Slave)), 316
  - RS-422A Port Settings for No-protocol Communications (Non-procedural), 317
  - RS-422A Port Settings for Serial Gateway, 317
  - Startup Mode Setting, 310
  - Sync Settings between Modules, 309
- cycle time, 19
  - computing, 286
  - errors, 247
  - maximum cycle time, 342, 347
  - present cycle time, 342, 347
  - settings, 324
- Cycle Time PV, 116
- Cycle Time Too Long Flag, 116, 247, 344, 347
- Cyclic Refresh Bit Area, 106, 107, 300
  - allocations, 108
- cyclic refreshing, 94, 105, 106

## **D**

- data areas
  - addressing, 269
- data control instructions
  - execution times, 367
- data exchange

- between Modules, 105
- data formats, 274
- Data Memory (DM) Area, 305
- data movement instructions
  - execution times, 362
- data shift instructions
  - execution times, 363
- debugging, 14, 120
- debugging instructions
  - execution times, 370
- deceleration
  - rate, 182
  - trapezoidal, 193
- decrement instructions
  - execution times, 363
- decrement pulse inputs, 153
- DI(802) instruction
  - disabling all interrupts, 141
- diagnosis, 120
- Differentiate Monitor Completed Flag, 349
- Differentiation Flags, 268
- Differentiation Overflow Error Flag, 342, 348
- dimensions, 43
  - Servo Relay Units, 79
- DIN Track, 57, 59
- DM data transfer, 105, 112
  - executing, 113
  - programming example, 114
- DM Read Request Bit, 113
- DM Transfer Size, 113
- DM Write Request Bit, 113
- downwardly differentiated instructions, 278
- ducts
  - wiring, 53

## **E**

- EC Directives, xix
- EI(694) instruction
  - enabling all interrupts, 141
- electrical noise, 85
- electronic cam control, 186
- End Modules
  - current consumption, 45
  - dimensions, 43
  - models, 32
  - overview, 6

Equals Flag, 283, 306  
error codes, 357  
Error Flag, 306  
error flags, 357  
error log, 120, 240  
Error Log Area, 240, 342, 347  
Error Log Pointer, 348  
error processing flowchart, 243  
errors  
    communications error, 248  
    Coordinator Module Fatal error, 248  
    Coordinator Module WDT error, 248  
    CPU error, 244  
    CPU standby, 244  
    cycle time overrun error, 247  
    error codes, 343, 347, 357  
    error log, 120, 240  
    fatal, 244  
    flags, 306  
    I/O Bus error, 246  
    I/O table setting error, 247  
    memory error, 246  
    Motion Control Module Monitor error, 247  
    non-fatal, 247  
    program error, 246  
    system FAL error, 247  
    system FALS error, 247  
    System Setup error, 247  
    troubleshooting, 241  
        Coordinator Module errors, 254  
        cycle time overrun error check, 251  
        environmental conditions check, 254  
        I/O check, 253  
        I/O setting error check, 252  
        input errors, 255  
        memory error check, 250  
        Motion Control Module errors, 255  
        output errors, 256  
        power supply check, 249  
        program error check, 250  
        System Setup error check, 251  
    user-programmed errors, 121, 240  
execution conditions  
    variations, 277

## **F**

failure alarms, 121  
failure diagnosis instructions  
    execution times, 370  
FAL Error Flag, 121, 247, 343, 347  
FAL errors, 247  
FAL(006) instruction, 121  
FALS Error Flag, 122, 247, 343, 347  
FALS errors, 247  
FALS(007) instruction, 122  
fatal errors, 244  
    (FALS(007)), 121  
FINS commands list, 128  
First Cycle Flag, 345, 347  
First DM Transfer Destination Word, 113  
First DM Transfer Source Word, 113  
flags, 268  
    Absolute No. of Rotations Read Completed Flag, 353  
    Absolute No. of Rotations Read Error Flag, 353  
    Absolute Offset Preset Error Flag, 353  
    Access Error Flag, 306  
    Always OFF Flag, 306  
    Always ON Flag, 306  
    Analog Offset/Gain Error Flag, 343, 348  
    Analog Output 1 Flags, 335, 351  
    Analog Output 2 Flags, 335, 351  
    Carry Flag, 306  
    Clock Pulses, 307  
    Condition Flags, 279, 305  
    Constant Cycle Time Exceeded Flag, 115, 344, 348  
    Coordinator Module Fatal Error Flag, 248, 343, 347  
    Coordinator Module WDT Error Flag, 248, 343, 347  
    Count Latched Flag, 353  
    Cycle Time Too Long Flag, 344, 347  
    Differentiate Monitor Completed Flag, 349  
    Differentiation Overflow Error Flag, 342, 348  
    Equals Flag, 306  
    Error Flag, 306  
    FAL Error Flag, 121, 247, 343, 347  
    FALS Error Flag, 121, 247, 343, 347  
    First Cycle Flag, 345, 347  
    Flash Memory DM Checksum Error Flag, 343, 348  
    Flash Memory Error Flag, 120, 343, 348  
    Greater Than Flag, 306  
    Greater Than or Equals Flag, 306  
    High-speed Counter 1 Status, 353  
    High-speed Counter 2 Status, 353  
    High-speed Counter Operating Flag, 353  
    I/O Bus Error Flag, 246, 347  
    I/O Setting Error Flag, 247, 343, 347  
    Illegal Instruction Error Flag, 342, 348  
    Less Than Flag, 306  
    Less Than or Equals Flag, 306  
    Measuring Flag, 353

Memory Error Flag, 246, 343, 347  
Memory Not Held Flag, 343, 348  
Motion Control Module Monitor Error Flag, 247  
Motion Control Module Monitoring Error Flag, 343, 347  
Negative Flag, 306  
No END Error Flag, 342, 348  
Not Equal Flag, 306  
Overflow Flag, 306  
Peripheral Port Error Flags, 348  
Peripheral Port Settings Changing Flag, 344  
Phase Z Input Reset Flag, 353  
Program Error Flag, 246, 342, 347  
Pulse Output 1 Status, 355  
Pulse Output 2 Status, 355  
Pulse Output Status, 332  
PV Overflow/Underflow Flag, 353  
Range Comparison Execution Results Flags, 341  
RS-232C Port Error Flags, 348  
RS-232C port related, 345, 348  
RS-422A port related, 345, 349  
Step Flag, 345, 347  
Subroutine Input Condition Flags, 263, 342, 347  
Sync Cycle Time Too Long Flag, 344, 348  
System Flags, 342  
System Setup Error Flag, 247, 343, 347, 348  
System Setup Error Location, 343  
Target Comparison In-progress Flag, 353  
Task Error Flag, 342, 348  
Trace Busy Flag, 349  
Trace Completed Flag, 349  
Trace Trigger Monitor Flag, 349  
Transfer Busy Flag, 113, 350  
Transfer Error Flag, 113, 344, 350  
UM Error Flag, 343, 348  
UM Overflow Error Flag, 342, 348  
Underflow Flag, 306

flash memory, 47  
    automatic backup, 119  
    Coordinator Modules, 93

Flash Memory DM Checksum Error Flag, 343, 348  
Flash Memory Error Flag, 120, 343, 348

floating-point decimal, 274  
floating-point math instructions  
    execution times, 366

flowchart  
    PLC cycle, 286

FQM1 Flexible Motion Controller Set  
    models, 32

FQM1 Patch Software, 32, 92, 232

Framing Error Flag, 348, 349

functions  
    list, 139

## **G**

Greater Than Flag, 283, 306  
Greater Than or Equals Flag, 306  
grounding, 61

## **H**

high-speed analog sampling, 223  
high-speed counter instructions  
    execution times, 368  
High-speed Counter Operating Flag, 338, 339, 353  
High-speed Counter Reset Bit, 155  
high-speed counters, 153  
    bit pattern output, 164  
    interrupts, 140, 155  
    latching PV, 159, 166  
    monitoring frequency, 158  
    monitoring movement, 157  
    procedure, 160  
        mode 1, 161  
        mode 2, 162  
    PV, 205  
    range comparison, 164  
    target-value comparison, 162

Host Link (SYSMAC WAY), 9, 124  
    commands, 127

Host Link System, 10

Host Link(SYSMAC WAY)  
    communications functions, 126

## **I**

I/O Bit Area, 300  
I/O Bus Error Flag, 246, 347  
I/O memory, 96  
    addresses, 358  
    addressing, 269  
    areas, 359  
    Coordinator Modules, 298  
    Motion Control Modules, 299  
    overview, 297  
    structure, 298, 299  
        Motion Control Modules, 299

I/O refreshing, 94, 301

- END refresh, 301
  - immediate refresh, 302
  - Motion Control Modules, 98
    - using IORF(097) instruction, 302
  - I/O response time, 291
    - calculating, 291
    - Coordinator Modules, 291
    - Motion Control Modules, 292
  - I/O Setting Error Flag, 247, 343, 347
  - I/O Table Setting error, 247
  - Illegal Instruction Error Flag, 342, 348
  - increment instructions
    - execution times, 363
  - increment pulse inputs, 153
  - Independent Pulse Output Flag, 355
  - indicators
    - error indications, 241
    - Motion Control Indicators, 38
  - inductive loads
    - surge suppressor, 86
  - INI(880) instruction, 152
    - pulse outputs, 170
  - initialization, 94, 98
  - input devices
    - wiring, 87
  - input instructions
    - execution times, 360
  - input interrupts, 140, 142, 341
    - application example, 145
    - modes, 142
      - procedure, 143
    - procedure, 143
    - specifications, 142
  - input pulses
    - frequency, 204
    - measuring, 25
  - inputs
    - pulse frequency, 204
  - inspections
    - procedures, 258
    - required tools, 259
  - installation, 13, 15
    - control panels, 53
    - DIN Track, 57
    - environment, 50
      - ambient conditions, 50
      - cooling, 50
    - precautions, 50
  - instructions
    - basic information, 267
    - block programs, 285
    - execution conditions, 277
    - execution times, 360
    - input and output instructions, 267, 269
    - input conditions, 277
    - input-differentiated, 277
    - instruction conditions, 267
    - loops, 268
    - non-differentiated, 277
    - operands, 268
    - programming locations, 269
    - variations, 277
  - interlocks, 268, 284
  - interrupt control instructions
    - execution times, 368
  - interrupt modes, 142
  - interrupt response time, 293
    - calculation example, 295
  - interrupts
    - clearing, 142
    - disabling, 141
    - enabling, 141
    - high-speed counter, 140
    - input, 140, 142
    - interval timer, 140, 146
    - priority, 140
    - processing time
      - Motion Control Modules, 294
    - pulse output, 140
  - interval timer interrupts, 140, 146
    - application example, 147
    - one-shot mode, 146
    - scheduled interrupt mode, 146
    - using, 146
  - isolation transformer, 60
- ## J
- JSB(982) instruction, 263
- ## L
- latch inputs
    - applicable instructions, 152
    - specifications, 152
  - leakage current
    - output, 90
  - Less Than Flag, 283, 306

Less Than or Equals Flag, 306

Linear Counter, 154

linear counter

    CCW rotation, 201

    CW rotation, 201

Linear Counter Mode, 205

linear mode, 180

logic instructions

    execution times, 365

## M

Maximum Cycle Time, 116

MCRO(099) instruction, 263

Measuring Flag, 338, 339, 353

Memory Backup Status Window, 119

Memory Error Flag, 246, 343, 347

memory map, 359

Memory Not Held Flag, 343, 348

momentary power interruption, 100

MONITOR mode, 99

monitoring, 14

Motion Control Module Monitoring Error Flag, 247, 343, 347

Motion Control Modules, 95

    built-in I/O refreshing, 98

    connections, 70

    connectors

        pin arrangement, 68

    constant cycle time, 115

    current consumption, 46

    Cyclic Refresh Area, 107

    data exchange with Coordinator Modules, 105

    dimensions, 43

    I/O memory, 299

    I/O memory structure, 299

    I/O response time, 292

    indicators, 38

    interrupt processing time, 294

    interrupt response time, 293

    models, 32

    overview, 5, 7

    specifications, 37

    System Setup, 112

    troubleshooting, 255

## N

Negative Flag, 283, 306

No END Error Flag, 342, 348

noise reduction

    electrical noise, 85

    external wiring, 86

non-fatal errors, 121, 247

no-protocol communications, 9, 10, 13, 124, 129

    end code, 130

    RS-232C port, 129

    RS-422A port, 136

    start code, 130

Not Equal Flag, 306

NT Links, 9, 10, 124

    1-to-N mode, 131

## O

one-shot pulse outputs, 167, 176, 188

    example, 194

    specifications, 169, 177

operands

    constants, 272

    description, 268

    specifying, 270

    text strings, 273

operating modes, 99

    effects of mode changes on counters, 304

    effects of mode changes on timers, 304

operation

    checking, 16

    checking operation, 14

    preparations, 13

    testing, 14, 17

output instructions

    execution times, 360

Overflow Flag, 306

Overrun Error Flag, 348, 349

## P

Parameter Area, 308, 359

    overview, 297

Parity Error Flag, 348, 349

password protection, 119

Peripheral Bus (Toolbus), 9, 125

    connections, 65

- Peripheral Devices, 6
- peripheral port
  - connecting a personal computer, 233
- Peripheral Port Communications Error Flag, 344, 348
- Peripheral Port Error Flags, 344, 348
- Peripheral Port Settings Changing Flag, 344, 348
- peripheral servicing, 94, 98
  - settings, 325
- personal computers
  - connecting, 233
  - connectors, 65
- phase differential inputs, 153
- Phase Z Input Reset Flag, 338, 339, 353
- phase-Z signal, 155
- PLC Setup, 14, 16
  - errors, 247
- PLCs
  - cooling, 50
- PLS2 Positioning Flag, 355
- PLS2(887) instruction, 182, 196
  - absolute position priority mode, 183
  - pulse output direction priority mode, 183
  - pulse outputs, 170
  - setting speed change cycle, 183
  - trapezoidal pulse output with acceleration/deceleration, 187
- Polled Units
  - settings, 133
- Polling Unit
  - setting, 133
- position control
  - operations, 21
- power flow
  - description, 267
- Power Holding Time, 101
- power interruptions
  - CPU operation for power interruptions, 100, 286
  - holding time, 101
  - instruction execution, 102
  - momentary interruptions, 100
- Power OFF Detection Time, 101
- power OFF operation, 100
- power OFF processing, 100
- power OFF timing chart, 101
- power supply
  - CPU processing for power interruptions, 100
- Power Supply Units
  - dimensions, 44
  - overview, 5
  - specifications, 33
  - wiring, 60
- precautions
  - general, xiv
  - output surge current, 90
  - output wiring, 89
  - periodic inspections, 258
  - programming, 279
  - replacing Modules, 259
  - safety, xiv
  - two-wire DC sensors, 88
  - using pulse outputs, 175
  - wiring, 85
- printing, 18
- Program Error Flag, 246, 342, 347
- PROGRAM mode, 99
- Programmable Terminals, 10
  - connection example, 66
- programming, 14, 16
  - basic information, 267
  - block programs, 268, 284
    - restrictions, 285
  - error flag, 347
  - error flags, 342
  - errors, 246
  - instruction locations, 269
  - power flow, 267
  - precautions, 279
  - printing the program, 18
  - running the program, 18
  - saving the program, 18
  - step programming, 284
    - restrictions, 285
  - subroutines, 262
  - tasks, 261
  - transferring the program, 14, 17
- Programming Devices
  - models, 32
- protection
  - using passwords, 118
- protocols, 9
- PRV(881) instruction, 152, 222
  - pulse outputs, 170
- PULS(886) instruction, 184, 196
  - pulse outputs, 170
- pulse and direction inputs, 153
- pulse counter timer, 178, 188
  - example, 194
  - specifications, 179

pulse inputs, 148  
    applicable instructions, 152  
    application examples, 162  
    connections, 71  
    high-speed counter, 153  
    internal circuit configuration, 152  
    mode, 204  
    specifications, 148, 150

Pulse Output Completed Flag, 355

pulse output direction priority mode, 183

Pulse Output Flag, 355

pulse output instructions  
    execution times, 368

Pulse Output Set Flag, 355

Pulse Output Status Flags, 332

pulse outputs, 167  
    accelerating frequency, 190  
    applicable instructions, 170  
    bit pattern outputs, 182  
    changing frequency, 190  
    connections, 73  
    details, 167  
    instructions, 170  
    interrupts, 140  
    modes, 168  
    number of, 169  
    one-shot, 169, 176, 188  
    operation modes, 194  
    operations, 173  
    precautions, 175  
    PV storage location, 169  
    range comparison, 182  
    signals, 169  
    specifications, 168, 169  
    startup conditions, 194, 196  
    target-value comparison interrupts, 179  
    with acceleration/deceleration, 185  
        trapezoidal, 187  
    without acceleration/deceleration, 184, 186  
        absolute positioning, 191  
        positioning, 189

PV Overflow/Underflow Flag, 338, 339, 353

## R

RAM memory, 358

range comparison, 156  
    bit pattern outputs, 182

Range Comparison Execution Results Flags, 341

read protection using passwords, 118

Read/Write DM Area, 96

refreshing  
    END, 222, 228  
    immediate, 222, 228  
    immediate refreshing, 277

Relative Pulse Output, 21

replacing Modules, 259

RS, 345

RS-232C port  
    connecting a personal computer, 233  
    specifications, 66  
    wiring, 64

RS-232C Port Communications Error Flag, 345, 348

RS-232C Port Error Flags, 345

RS-232C Port Reception Completed Flag, 345, 348

RS-232C Port Reception Overflow Flag, 345, 348

RS-232C Port Send Ready Flag, 345, 348

RS-232C Port Settings Changing Flag, 345, 348

RS-422A Port Communications Error Flag, 345, 349

RS-422A Port Error Flags, 345, 349

RS-422A Port Reception Completed Flag, 345, 349

RS-422A Port Reception Overflow Flag, 345, 349

RS-422A Port Send Ready Flag, 345

RS-422A Port Settings Changing Flag, 345, 349

RUN mode, 99

## S

safety precautions  
    *See* precautions

sample programs  
    connecting W-series Servo Driver, 209

Screw-less Clamp Terminal Blocks  
    wiring, 76, 79

sequence control instructions  
    execution times, 361

serial communications, 9  
    functions, 124  
    protocols, 9

serial communications instructions  
    execution times, 370

Serial Gateway, 3, 9, 12, 125, 134  
    Smart Active Parts, 135  
    system configuration, 134  
    System Setup, 135

Serial PLC Link Bit Area, 301

Serial PLC Links, 9, 11, 124, 132

- operation procedure, 133
- PLC Setup (Master), 134
- System Setup (Slave), 134
- Servo Drivers
  - compatible with absolute encoder, 207
  - compatible with absolute encoders
    - timing chart, 209
  - functions
    - compatible with absolute encoders, 199
- Servo Relay Units, 6
  - dimensions, 45, 79
  - functions, 76
  - models, 32
  - nomenclature, 76
  - wiring, 75
    - example, 82
- setup
  - initial setup, 14
  - preparations for operation, 13
- short-circuit protection, 89
- signed binary data, 274
- Slot No. of Motion Control Module for DM Transfer, 113
- Smart Active Parts, 12
  - communications settings, 135
- SMARTSTEP Servo Drivers, 6, 12
- software reset, 155
- special math instructions
  - execution times, 366
- specifications
  - functions, 35
  - general, 32
  - I/O, 37, 40
  - Motion Control Modules, 37
  - performance, 39
  - Power Supply Unit, 33
  - RS-232C port, 66
- SPED(885) instruction, 184, 190
  - pulse outputs, 170
- speed change cycle, 183
- speed control
  - operations, 21
- stack processing
  - execution times, 367
- startup, 94
- startup mode
  - specifying, 118
- STC(040) instruction, 306
- Step Flag, 345, 347
- step instructions
  - execution times, 369
  - step programming, 284
- STIM(980) instruction, 188
- Subroutine Input Condition Flags, 263, 342, 347
- subroutine instructions
  - execution times, 367
- subroutines, 284
- super capacitors, 47
- Support Software
  - See* personal computer
- switch settings, 15
- symbol math instructions
  - execution times, 364
- Sync Cycle Time, 19, 111
- Sync Cycle Time Too Long Flag, 344, 348
- sync cycles, 19
- Sync Mode, 19, 96, 97, 104, 109
  - constant cycle time, 115
- synchronization
  - between Modules, 109
  - operations, 19
- Synchronization between Modules, 111
- synchronous data
  - selecting, 112
- Synchronous Data Link Bit Area, 19, 20, 106, 109, 110, 301
- synchronous refreshing, 105
- system configuration, 4
  - Host Link, 10
  - NT Links, 10
  - serial communications, 9
- System Flags, 342
- System Setup, 93, 96, 308
  - analog I/O, 218
  - constant cycle time, 324
  - Coordinator Modules, 111, 309
  - fixed peripheral servicing time, 325
  - Motion Control Modules, 112
  - overview, 309
  - peripheral port settings, 323
  - RS-232C port settings, 323
  - Serial Gateway, 135
  - startup mode, 323
  - watch cycle time, 324
- System Setup Error Flag, 247, 343, 347, 348
- System Setup Error Location, 343



**T**

- table data processing instructions
  - execution times, 367
- Target Comparison Flag, 355
- Target Comparison In-progress Flag, 338, 339, 353
- Target Frequency Not Reached Flag, 355
- target-value comparison, 155
  - interrupts, 162, 179
- Task Error Flag, 342, 348
- Temporary Relay Area, 302
- terminal screws, 61
- text strings
  - operands, 273
- Timeout Error Flag, 348, 349
- Timer Area, 303
- Timer Completion Flags, 359
- timer instructions
  - execution times, 361
- timing
  - controlling, 28
- Toolbus (Peripheral Bus), 9, 125
  - connections, 65
- Trace Busy Flag, 349
- Trace Completed Flag, 349
- Trace Trigger Monitor Flag, 349
- Transfer Busy Flag, 113, 344, 350
- Transfer Error Flag, 113, 344, 350
- trapezoidal acceleration/deceleration, 193
- two-wire DC sensors
  - precautions, 88

**U**

- UM Error Flag, 343, 348
- UM Overflow Error Flag, 342, 348
- Underflow Flag, 306
- unsigned binary data, 274
- upwardly differentiated instructions, 277

**V**

- virtual pulse outputs, 212
  - application example, 215
  - AXIS instruction, 213

**W**

- watch cycle time, 116
- Windows, 233
- wiring, 13, 15
  - examples, 71
  - I/O devices, 87
  - installing wiring ducts, 53
  - methods, 74
  - noise reduction, 86
  - Power Supply Units, 60
  - precautions, 50, 85, 89
    - output surge current, 90
  - RS-232C port, 64
  - Screw-less Clamp Terminal Blocks, 76, 79
  - wire size, 75
- Work Area, 302
- Work Areas (in CIO Area), 301
- W-series Servo Drivers, 6, 12
  - absolute encoder type
    - connections, 72
  - sample program, 209



## Revision History

A manual revision code appears as a suffix to the catalog number on the front cover of the manual.

Cat. No. O010-E1-01

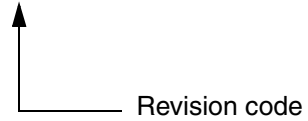

The following table outlines the changes made to the manual during each revision. Page numbers refer to the previous version.

Revision code	Date	Revised content
01	December 2004	Original production



**OMRON CORPORATION**

FA Systems Division H.Q.  
66 Matsumoto  
Mishima-city, Shizuoka 411-8511  
Japan  
Tel: (81)55-977-9181/Fax: (81)55-977-9045

**Regional Headquarters**

**OMRON EUROPE B.V.**

Wegalaan 67-69, NL-2132 JD Hoofddorp  
The Netherlands  
Tel: (31)2356-81-300/Fax: (31)2356-81-388

**OMRON ELECTRONICS LLC**

1 East Commerce Drive, Schaumburg, IL 60173  
U.S.A.  
Tel: (1)847-843-7900/Fax: (1)847-843-8568

**OMRON ASIA PACIFIC PTE. LTD.**

83 Clemenceau Avenue,  
#11-01, UE Square,  
Singapore 239920  
Tel: (65)6835-3011/Fax: (65)6835-2711

# OMRON

**Authorized Distributor:**