

**Omron TM Collaborative  
Robot S Series: TM5S /  
TM6S / TM7S / TM12S /  
TM14S / TM20S  
Hardware Installation  
Manual**



Original Instruction

This Manual contains information of the Techman Robot product series (hereinafter referred to as the TM Robot). The information contained herein is the property of Techman Robot Inc. (hereinafter referred to as the Corporation). No part of this publication may be reproduced or copied in any way, shape or form without prior authorization from the Corporation. No information contained herein shall be considered an offer or commitment. It may be subject to change without notice. This Manual will be reviewed periodically. The Corporation will not be liable for any error or omission.

**TM** logo is registered trademark of TECHMAN ROBOT INC. in Taiwan and other countries and the company reserves the ownership of this manual and its copy and its copyrights.

# Terms and Conditions Agreement

## Warranty Limitations of Liability

### Warranties

---

- Exclusive Warranty

Omron's exclusive warranty is that the Products will be free from defects in materials and workmanship for a period of twelve months from the date of sale by Omron (or such other period expressed in writing by Omron). Omron disclaims all other warranties, express or implied.

- Limitations

OMRON MAKES NO WARRANTY OR REPRESENTATION, EXPRESS OR IMPLIED, ABOUT NON-INFRINGEMENT, MERCHANTABILITY OR FITNESS FOR A PARTICULAR PURPOSE OF THE PRODUCTS. BUYER ACKNOWLEDGES THAT IT ALONE HAS DETERMINED THAT THE PRODUCTS WILL SUITABLY MEET THE REQUIREMENTS OF THEIR INTENDED USE.

Omron further disclaims all warranties and responsibility of any type for claims or expenses based on infringement by the Products or otherwise of any intellectual property right.

- Buyer Remedy

Omron's sole obligation hereunder shall be, at Omron's election, to (i) replace (in the form originally shipped with Buyer responsible for labor charges for removal or replacement thereof) the non-complying Product, (ii) repair the non-complying Product, or (iii) repay or credit Buyer an amount equal to the purchase price of the non-complying Product; provided that in no event shall Omron be responsible for warranty, repair, indemnity or any other claims or expenses regarding the Products unless Omron's analysis confirms that the Products were properly handled, stored, installed and maintained and not subject to contamination, abuse, misuse or inappropriate modification. Return of any Products by Buyer must be approved in writing by Omron before shipment. Omron Companies shall not be liable for the suitability or unsuitability or the results from the use of Products in combination with any electrical or electronic components, circuits, system assemblies or any other materials or substances or environments. Any advice, recommendations or information given orally or in writing, are not to be construed as an amendment or addition to the above warranty.

See <http://www.omron.com/global/> or contact your Omron representative for published information.

### Limitations of Liability: Etc.

OMRON COMPANIES SHALL NOT BE LIABLE FOR SPECIAL, INDIRECT, INCIDENTAL, OR CONSEQUENTIAL DAMAGES, LOSS OF PROFITS OR PRODUCTION OR COMMERCIAL LOSS IN ANY WAY CONNECTED WITH THE PRODUCTS, WHETHER SUCH CLAIM IS BASED IN CONTRACT, WARRANTY, NEGLIGENCE OR STRICT LIABILITY.

Further, in no event shall liability of Omron Companies exceed the individual price of the Product on which liability is asserted.

### Application Considerations

#### Suitability of Use

Omron Companies shall not be responsible for conformity with any standards, codes or regulations which apply to the combination of the Product in the Buyer's application or use of the Product. At Buyer's request, Omron will provide applicable third party certification documents identifying ratings and limitations of use which apply to the Product. This information by itself is not sufficient for a complete determination of the suitability of the Product in combination with the end product, machine, system, or other application or use. Buyer shall be solely responsible for determining appropriateness of the particular Product with respect to Buyer's application, product or system. Buyer shall take application responsibility in all cases.

NEVER USE THE PRODUCT FOR AN APPLICATION INVOLVING SERIOUS RISK TO LIFE OR PROPERTY WITHOUT ENSURING THAT THE SYSTEM AS A WHOLE HAS BEEN DESIGNED TO ADDRESS THE RISKS, AND THAT THE OMRON PRODUCT(S) IS PROPERLY RATED AND INSTALLED FOR THE INTENDED USE WITHIN THE OVERALL EQUIPMENT OR SYSTEM.

#### Programmable Products

Omron Companies shall not be responsible for the user's programming of a programmable Product, or any consequence thereof.

### Disclaimers

#### Performance Data

Data presented in Omron Company websites, catalogs and other materials is provided as a guide for the user in determining suitability and does not constitute a warranty. It may represent the result of Omron's test conditions and the user must correlate it to actual application requirements. Actual performance is subject to the Omron's Warranty and Limitations of Liability.

---

- Change in Specifications

Product specifications and accessories may be changed at any time based on improvements and other reasons. It is our practice to change part numbers when published ratings or features are changed, or when significant construction changes are made. However, some specifications of the Product may be changed without any notice. When in doubt, special part numbers may be assigned to fix or establish key specifications for your application. Please consult with your Omron representative at any time to confirm actual specifications of purchased Product.

### Errors and Omissions

---

Information presented by Omron Companies has been checked and is believed to be accurate; however, no responsibility is assumed for clerical, typographical or proofreading errors or omissions.

Revision History Table.....	12
1. Product Description.....	13
1.1 Product Description.....	13
1.2 How Can I Get Help?.....	13
1.3 Disposal and Environment.....	13
2. Safety Information.....	15
2.1 Overview.....	15
2.2 Warning and Caution Symbols.....	15
2.3 Limitations on Liability.....	15
2.4 Safety Precautions.....	15
2.5 Validation and Liability.....	16
2.6 Statement of Responsibilities for Cybersecurity Threats.....	17
2.7 General Safety Warning.....	18
2.8 Risk Assessment.....	18
2.9 Emergency Stop.....	18
2.10 Joint Movement without Drive Power.....	19
2.11 Labels.....	20
3. Transportation and Storage.....	22
4. System Hardware.....	23
4.1 Overview.....	23
4.2 System Overview.....	23
4.2.1 Robot Arm.....	24
4.2.1.1 Dimension Drawings of Robot.....	24
4.2.1.2 Robot Assembly Diagram.....	34
4.2.1.3 Range of Motion.....	36
4.2.1.4 Payload and Torque.....	44
4.2.1.5 Robot Arm Installation.....	49
4.2.2 Robot End Module.....	52
4.2.2.1 End Module Components.....	52
4.2.2.2 Flange Surface of the Robot End.....	54
4.2.2.3 End Mounting Caution.....	55
4.2.2.4 End Indication Light Ring Table.....	55
4.2.3 Control Box.....	56
4.2.3.1 Robot Stick.....	61
4.2.3.2 TM Screen (Optional).....	65
4.2.4 Robot Light Module.....	67

4.2.4.1 Light Module Surface.....	67
4.2.4.2 Install Light Module.....	67
4.3 Operating Position of TM Robot with AGV/AIV.....	69
4.4 Working distance and field of view of TM Robot's EIH camera.....	69
5. Electrical Interface.....	71
5.1 Overview.....	71
5.2 Electrical Warnings and Cautions.....	71
5.3 Control Box.....	71
5.3.1 Safety Connector.....	72
5.3.1.1 Safety Input Connector.....	72
5.3.1.2 Safety Output Connector.....	74
5.3.2 Power Connector.....	75
5.3.3 Digital In/Out.....	76
5.3.3.1 Digital Input.....	76
5.3.3.2 Digital Output.....	79
5.3.4 Analog In/Out.....	83
5.3.5 System Remote Power ON/OFF.....	84
5.3.6 AUTO MODE Play Confirm Port.....	87
5.3.7 EtherCAT: For EtherCAT Slave I/O Expansion.....	88
5.3.8 USB Port.....	89
5.3.9 COM Port.....	89
5.4 Tool End I/O Interface.....	89
5.4.1 I/O Terminals.....	89
5.4.2 Connecting Tool End Digital Output.....	91
5.4.3 Connecting Tool End Digital Input.....	91
5.4.4 Connecting Tool End Analog Input.....	91
5.5 Control Box Interfaces.....	93
5.6 Control Box Power Interface and Robot Interface.....	97
5.6.1 Control Box Power Interface.....	97
5.6.2 Robot Interface.....	101
5.6.3 SEMI Emergency Off Interfaces (SEMI series exclusive).....	102
5.6.3.1 TM5S-M SEMI / TM5S-MX SEMI / TM7S-M SEMI / TM7S-MX SEMI / TM6S-M SEMI / TM6S-MX SEMI / TM12S-M SEMI / TM12S-MX SEMI / TM14S-M SEMI / TM14S-MX SEMI Series.....	102
6. Unboxing & Installation.....	103
6.1 Overview.....	103
6.2 Inspecting the Equipment.....	103
6.2.1 Before Unpacking.....	103

6.2.2 Upon Unpacking .....	103
6.3 Unboxing .....	104
6.3.1 Carton Types .....	104
6.3.2 Contents of Each Carton .....	105
6.4 Installing Your Robot .....	108
6.4.1 Remove the Control Box .....	109
6.4.2 Verification Before Removal of the Robot Arm .....	111
6.4.3 Removal of the Robot Arm and Tightening .....	112
6.4.4 Connect the Robot and the Control Box .....	114
6.4.5 Installing the Control Box and Power Supply Unit Separately (for Nano DC only) .....	115
6.4.6 Mounting Direction .....	117
7. Maintenance and Repair .....	118
Appendix A. Technical Specifications .....	121

## Tables

Table 1: Manual Title & Description .....	13
Table 2: Danger, Warning, and Caution Symbols .....	15
Table 3: Denotation of Labels .....	20
Table 4: Rated Torque and Limit for Repeated Peak Torque of TM5S, TM7S, TM6S, TM12S, TM14S, and TM20S Robot Series .....	48
Table 5: Specifications of the Robot Stick .....	61
Table 6: Robot Stick Basic Functions .....	64
Table 7: Robot Stick Advanced Functions .....	64
Table 8: Reference of the Symbol and Unit in Calculation the Torque Load of the Light Module .....	67
Table 9: Electrical Specification of the Light Module .....	68
Table 10: The Relation between the Working Distance and the Field of View .....	70
Table 11: Analog In & Analog Out .....	84
Table 12: 8-pin Digital I/O Connectors of Cable .....	90
Table 13: 8-pin Digital I/O Connector of Robot .....	90
Table 14: Analog Input Range .....	91
Table 15: TM5S / TM7S / TM5S-X / TM7S-X Electrical Specifications .....	99
Table 16: TM6S / TM12S / TM14S / TM20S / TM6S-X / TM12S-X / TM14S-X / TM20S-X Electrical Specifications .....	99
Table 17: TM5S-M / TM7S-M / TM5S-MX / TM7S-MX Series Electrical Specifications .....	99
Table 18: TM6S-M / TM12S-M / TM14S-M / TM6S-MX / TM12S-MX / TM14S-MX Series Electrical Specifications .....	100
Table 19: TM5S-NM / TM5S-NMX / TM7S-NM / TM7S-NMX / TM6S-NM / TM6S-NMX / TM12S-NM /	

TM12S-NMX / TM14S-NM / TM14S-NMX / TM20S-NM / TM20S-NMX Series Electrical Specifications

(Nano DC) .....	100
Table 20: The Robot Arm Carton Contents.....	105
Table 21: The Control Box Carton Contents.....	108
Table 22: The SEMI Emergency OFF Switch Carton Contents.....	108
Table 23: Summary of the Preventive Maintenance Procedures and Guidelines .....	118
Table 24: Technical Specifications (TM5S / TM7S / TM6S Series) .....	122
Table 25: Technical Specifications (TM12S / TM14S / TM20S Series) .....	124

**Figures**

Figure 1: Pin position for brake releasing .....	19
Figure 2: Locations of Labels .....	21
Figure 3: System Overview.....	23
Figure 4: Dimension of TM5S / TM5S-M / TM5S-NM.....	24
Figure 5: Dimension of TM7S / TM7S-M / TM7S-NM.....	25
Figure 6: Dimension of TM6S / TM6S-M / TM6S-NM.....	26
Figure 7: Dimension of TM12S / TM12S-M / TM12S-NM / TM20S / TM20S-NM .....	27
Figure 8: Dimension of TM14S / TM14S-M / TM14S-NM.....	28
Figure 9: Dimension of TM5S-X / TM5S-MX / TM5S-NMX .....	29
Figure 10: Dimension of TM7S-X / TM7S-MX / TM7S-NMX .....	30
Figure 11: Dimension of TM6S-X / TM6S-MX / TM6S-NMX .....	31
Figure 12: Dimension of TM12S-X / TM20S-X / TM12S-MX / TM12S-NMX / TM20S-NMX .....	32
Figure 13: Dimension of TM14S-X / TM14S-MX / TM14S-NMX .....	33
Figure 14: Side View of TM5S Series Movement Range Diagram .....	36
Figure 15: Pictorial view of TM5S Series Movement Range Diagram .....	37
Figure 16: Top View of TM5S Series Movement Range.....	37
Figure 17: Side View of TM7S Series Movement Range Diagram .....	38
Figure 18: Pictorial View of TM7S Series Movement Range.....	38
Figure 19: Top View of TM7S Series Movement Range.....	39
Figure 20: Side View of TM6S Series X Movement Range Diagram .....	39
Figure 21: Pictorial view of TM6S Series Movement Range Diagram .....	40
Figure 22: Top View of TM6S Series Movement Range.....	40
Figure 23: Side View of TM12S / TM20S Series Movement Range Diagram.....	41
Figure 24: Pictorial view of TM12S / TM20S Series Movement Range Diagram.....	41
Figure 25: Top view of TM12S / TM20S Series Movement Range Diagram.....	42
Figure 26: Side view of TM14S Series Movement Range Diagram .....	43
Figure 27: Pictorial view of TM14S Series Movement Range Diagram .....	43

Figure 28: Top View of TM14S Series Movement Range Diagram .....	44
Figure 29: Relationship between Payload and the Center of Gravity Offset in TM5S Series .....	45
Figure 30: Relationship between Payload and the Center of Gravity Offset in TM7S Series .....	45
Figure 31: Relationship between Payload and the Center of Gravity Offset in TM6S Series .....	46
Figure 32: Relationship between Payload and the Center of Gravity Offset in TM12S Series .....	46
Figure 33: Relationship between Payload and the Center of Gravity Offset in TM14S Series .....	47
Figure 34: Relationship between Payload and the Center of Gravity Offset in TM20S / TM20S-X .....	47
Figure 35: Relationship between Payload and the Center of Gravity Offset in TM20S-NMX/ TM20S-NM.....	48
Figure 36: Bottom View of Robot Base (for TM5S / TM7S Series) .....	50
Figure 37: Bottom View of Robot Base (for TM6S / TM12S / TM14S / TM20S Series) .....	50
Figure 38: Grounding position for the robot.....	51
Figure 39: References of TM5S / TM7S / TM6S / TM12S / TM14S / TM20S Series End Module Components .....	52
Figure 40: References of TM5S-X / TM7S-X / TM6S-X / TM12S-X / TM14S-X / TM20S-X Series End Module Components .....	53
Figure 41: References of the Flange Surface of the Robot End .....	54
Figure 42: The Exterior and Diagram of the Control Box .....	56
Figure 43: Dimensions of the DC Control Box.....	57
Figure 44: Dimensions of the DC SEMI Control Box.....	58
Figure 45: Dimensions of the Nano DC Control Box.....	59
Figure 46: Grounding position for the Control Box .....	60
Figure 47: Waterproof Rubber Plugs of the Control Box .....	60
Figure 48: Dimensions of the Robot Stick .....	61
Figure 49: Robot Stick (front) .....	62
Figure 50: Robot Stick (back) .....	62
Figure 51: Operation of the Enabling Switch .....	63
Figure 52: TM Teach Pendant (consisting of the TM Screen and Robot Stick).....	65
Figure 53: Light Module Surface .....	67
Figure 54: Calculation the Torque Load of the Light Module .....	68
Figure 55: Electrical Polarity of Fill Light Cable .....	68
Figure 56: Top View of TM Robot Mounted on the AGV/AIV .....	69
Figure 57: Working Distance and Field of View of TM Robot's EIH camera .....	70
Figure 58: Control Box I/O Configuration .....	71
Figure 59: Safety Input Connector.....	72
Figure 60: The Wiring Diagram Example of Switch Type Safety Device.....	73
Figure 61: The Wiring Diagram Example of PNP Output Type Safety Device (1/2).....	73
Figure 62: The Wiring Diagram Example of PNP Output Type Safety Device (2/2).....	74

Figure 63: Safety Output Connector .....	74
Figure 64: Safety Output Connector Wiring Diagram .....	75
Figure 65: Power Connector .....	76
Figure 66: Digital Input.....	77
Figure 67: Set to Sink Input Type .....	78
Figure 68: Set to Source Input Type .....	79
Figure 69: Digital Output.....	80
Figure 70: Set to Sink Output Type .....	81
Figure 71: Set to Source Output Type .....	82
Figure 72: Analog In.....	83
Figure 73: Analog Out.....	84
Figure 74: Remote Power ON/OFF of AC Control Box (via RMT2 interface) .....	85
Figure 75: Remote Power ON/OFF of DC Control Box, connected with push-button switches (via RMT1 and RMT2 interfaces).....	86
Figure 76: Remote Power ON/OFF of DC Control Box, connected with a relay switch (via RMT1 and RMT2 interfaces).....	87
Figure 77: AUTO MODE Play Confirm Port.....	88
Figure 78: EtherCAT .....	88
Figure 79: Connecting Tool End Digital Output .....	91
Figure 80: Connecting Tool End Digital Input .....	91
Figure 81: Connecting Tool End Analog Input .....	92
Figure 82: Front View of the Control Box (AC).....	94
Figure 83: Front View of the Control Box (DC).....	94
Figure 84: Side View of the Control Box (DC).....	94
Figure 85: Front View of the Control Box (DC SEMI).....	95
Figure 86: Side View of the Control Box (DC SEMI).....	95
Figure 87: Interfaces of Control Box (AC) .....	96
Figure 88: Interfaces of the Control Box (DC and DC SEMI).....	96
Figure 89: Interfaces of the Control Box (Nano DC) .....	97
Figure 90: Control Box Power Interfaces (AC, DC, and DC SEMI).....	98
Figure 91: Control Box Power Interfaces (Nano DC) .....	98
Figure 92: Robot Interface .....	101
Figure 93: TM5S-M SEMI / TM5S-MX SEMI / TM7S-M SEMI / TM7S-MX SEMI / TM6S-M SEMI / TM6S-MX SEMI / TM12S-M SEMI / TM12S-MX SEMI / TM14S-M SEMI / TM14S-MX SEMI Emergency Off Interface .....	102
Figure 94: Robot Arm Carton.....	104
Figure 95: Control Box Carton (AC) .....	104

---

Figure 96: Control Box Carton (DC and DC SEMI) .....	105
Figure 97: Nano DC Control Box Carton .....	105
Figure 98: Moving the Control Box (1/2).....	109
Figure 99: Moving the Control Box (2/2).....	110
Figure 100: Mounting Points and Recommended Cooling Clearance for Nano DC Control Boxes .....	111
Figure 101: Moving the Robot Arm (1/2) .....	112
Figure 102: Moving the Robot Arm (2/2) .....	112
Figure 103: Connecting the Robot and the Control Box.....	114
Figure 104: Connecting a Nano DC Control Box to its Power Supply Unit .....	115
Figure 105: Mounting Holes for Nano DC Power Supply Unit.....	116
Figure 106: Air Filter Tray (the circled parts) .....	120

## Revision History Table

Revision	Date	Revised Content
A	October, 2025	Original release
B	May, 2026	Minor revision

# 1. Product Description

## 1.1 Product Description

The TM Robot is a six-axis robot with power and force limiting function featuring simple programming, innovative integrated vision capabilities together with the latest safety functionality to run at full speed with barriers and operate in collaborative workspace.

## 1.2 How Can I Get Help?

You can access information sources on the corporate website:

<http://www.ia.omron.com/>

### Related Manuals

This manual covers the hardware installation, operation and user maintenance of TM Robot. See the following table for additional available manuals.

Manual Title	Description
Omron TM Collaborative Robot S Series: Safety Manual (Cat. No. I688)	Contains safety information for TM Robots.
Omron TM Collaborative Robot: Software Manual TMFlow, Version 2 (Cat. No. I689)	Instructions for use of TMflow software.
Omron TM Collaborative Robot TMVision Software Manual (Cat. No. I690)	Instructions for use of TMvision software.

Table 1: Manual Title & Description

## 1.3 Disposal and Environment

TM Robots must be disposed of in accordance with the applicable legislation, regulations, and codes by the authorities.

TM Robots are produced with restricted used of hazardous substances to protect the environment; as defined by the Europe RoHS directive 2011/65/EU. These substances include cadmium, lead, mercury, hexavalent chromium, polybrominated biphenyls (PBBs), polybrominated diphenyl ethers (PBDEs), butyl benzyl phthalate (BBP), dibutyl phthalate (DBP), bis(2-ethylhexyl) phthalate (DEHP), and diisobutyl phthalate (DIBP).

To ensure the accuracy and timeliness of substance identification information, please consult the latest lists and identification information specified in the RoHS directive and the European Chemicals Agency's announcements.

RoHS Directive 2011/65/EU and its amendments: <https://eur-lex.europa.eu/eli/dir/2011/65>

---

The following symbols are affixed on the respective manuals to indicate conformity with the above legislation.



## 2. Safety Information

### 2.1 Overview

Users should read, understand and abide by the safety information provided in this manual before using the TM Robot.

### 2.2 Warning and Caution Symbols

The table below shows the definitions of the warning and caution levels used in this manual. Pay close attention to them when reading the manual, and observe them to avoid personal injuries or equipment damage.



**DANGER:**

Identifies an imminently hazardous situation which, if not avoided, is likely to result in serious injury, and might result in death or severe property damage.



**WARNING:**

Identifies a potentially hazardous situation which, if not avoided, will result in minor or moderate injury, and might result in serious injury, death, or significant property damage.



**CAUTION:**

Identifies a potentially hazardous situation which, if not avoided, might result in minor injury, moderate injury, or property damage.

Table 2: Danger, Warning, and Caution Symbols

### 2.3 Limitations on Liability

Even if the safety instructions are followed, any safety information in the manual shall not be considered as a guarantee that the product will not cause any personal injury or property damage.

### 2.4 Safety Precautions




**DANGER:**

This product can cause serious injury or death, or damage to itself and other equipment, if the following safety precautions are not observed.

- All personnel who install, operate, teach, program, or maintain the system must read the *Hardware installation Manual*, *Omron TM Collaborative Robot: Software Manual TMFlow, Version 2 (Cat. No. I689)*, and *Omron TM Collaborative Robot S Series: Safety Manual (Cat. No. I688)* according to the software and hardware version of this product, and complete a training course for their responsibilities in regard to the robot.



Read Manual and Impact Warning Labels

- All personnel who design the robot system must read the *Hardware installation Manual, Omron TM Collaborative Robot: Software Manual TMFlow, Version 2 (Cat. No. I689)*, and *Omron TM Collaborative Robot S Series: Safety Manual (Cat. No. I688)* according to the software and hardware version of this product, and must comply with all local and national safety regulations for the location in which the robot is installed.
- The TM Robot must be used according to its intended use.
- Results of the risk assessment may require the use of additional risk reduction measures.
- Power to the robot and its power supply must be locked out and tagged out or have means to control hazardous energy or implement energy isolation before any maintenance is performed.
-  Dispose of the product in accordance with the relevant rules and regulations of the country or area where the product is used.

## 2.5 Validation and Liability

The information contained herein neither includes how to design, install, and operate a complete robotic arm system, nor involves the peripherals that may affect the safety of the complete system. The integrators of the robot should understand the safety laws and regulations in their countries and prevent hazards from occurring in the complete system.

This includes but is not limited to:

- Risk assessment of the whole system
- Adding other machines and additional risk reduction measures based on the results of the risk assessment
- Using appropriate software safety features
- Ensuring Users will not modify any safety measures
- Ensuring all systems are correctly designed and installed
- Clearly labeling user instructions
- Clearly marking the contact information for the integrator
- Making relevant documents accessible, including the risk assessment, and this manual



### **CAUTION:**

This product is a partly complete machine. The design and installation of the complete system must comply with the safety standards and regulations in the country of use. Users and integrators of the robot should understand the safety laws and regulations in their countries and prevent major hazards from occurring in the complete system.

## 2.6 Statement of Responsibilities for Cybersecurity Threats

To maintain the security and reliability of the system, a robust cybersecurity defense program should be implemented, which may include some or all of the following:

### **Anti-virus protection**

- Install the latest commercial-quality anti-virus software on the computer connected to the control system and keep the software and virus definitions up-to-date.
- Scan USB drives or other external storage devices before connecting them to control systems and equipment.

### **Security measures to prevent unauthorized network access**

- Install physical controls so that only authorized personnel can access control systems and equipment.
- Reduce connections to control systems and equipment via networks to prevent access from untrusted devices.
- Install firewalls to block unused communications ports and limit communication between systems. Limit access between control systems and systems from the IT network.
- Control remote access and adopt multifactor authentication to devices with remote access to control systems and equipment.
- Set strong password policies and monitor for compliance frequently.

### **Data input and output protection**

- Backup data and keep the data up-to-date periodically to prepare for data loss.
- Validate backups and retention policies to cope with unintentional modification of input/output data to control systems and equipment.
- Validate the scope of data protection regularly to accommodate changes.
- Check validity of backups by scheduling test restores to ensure successful recovery from incidents.
- Safety design, such as emergency shutdown and fail-soft operations in case of data tampering and incidents.

### **Additional recommendations**

- When using an external network environment to connect to an unauthorized terminal such as a SCADA, HMI or to an unauthorized server may result in network security issues such as spoofing and tampering.
- You must take sufficient measures such as restricting access to the terminal, using a terminal equipped with a secure function, and locking the installation area by yourself.
- When constructing network infrastructure, communication failure may occur due to cable disconnection or the influence of unauthorized network equipment.
- Take adequate measures, such as restricting physical access to network devices, by means such as locking the installation area.
- When using devices equipped with an SD Memory Card, there is a security risk that a third party may acquire, alter, or replace the files and data in the removable media by removing or unmounting the media.

- Please take sufficient measures, such as restricting physical access to the Controller or taking appropriate management measures for removable media, by means of locking and controlling access to the installation area.
- Educate employees to help them identify phishing scams received via email on systems that will connect to the control network.

## 2.7 General Safety Warning

1. The measured noise level does not exceed 70 dB(A).
2. Environmental Conditions:
  - Ambient air temperature: 0°C ~ +50°C
  - Ambient relative humidity: < 85%
  - Transportation & Storage condition: -20°C ~ +60°C
  - Transportation & Storage humidity: < 75%
  - The robot needs to be protected from shock or vibration
  - Observe ESD precautions when installing or removing robot



### **DANGER:**

Power off the robot before removing the joint covers to prevent electric shock and arc flash hazard.

## 2.8 Risk Assessment

Before installing or using this product, users must first carry out the necessary risk assessment based on the conditions of use, and pay attention to the potential remaining risk addressed by the Corporation. Refer to and abide by the relevant chapters in *Omron TM Collaborative Robot S Series: Safety Manual (Cat. No. I688)* in accordance with its software and hardware version.

## 2.9 Emergency Stop

If any accidents occur during the operation of the robot, Users can stop all movement by pressing the Emergency Stop switch. When the robot stops, users must ensure that all hazards are eliminated before manually restarting the robot. The Emergency Stop switch is only for use in critical conditions. To stop the robot during normal operations use the Stop Button on the system controller. When users press the Emergency Stop switch, the TM Robot will disconnect power from the robot and activate the brakes after the robot motion is stopped. The indication light ring of the robot will not display light.

Once the risk assessment has been conducted, if an Emergency Stop switch needs to be installed, the selected device must comply with the requirements of IEC 60204-1. After an Emergency Stop, factory reset, or any other safety incident, refer and abide by the relevant chapters in *Omron TM Collaborative Robot S Series: Safety Manual (Cat. No. I688)* in accordance with its software and hardware version.

## 2.10 Joint Movement without Drive Power

When there is no drive power in the robot, this means the robot is powered off or has power loss. These situations occur when the robot loses external power entirely. Regarding how to operate a robot without drive power as well as what safety precautions should be taken when using such a robot, refer to the relevant chapters in the *Omron TM Collaborative Robot S Series: Safety Manual (Cat. No. I688)* and follow the instructions. If it is necessary to move the robot arm or joint manually, users can release the brake of each joint manually.

To release the brake of each joint manually:

1. Initiate shutdown of the robot system and ensure the robot is powered OFF. If it is an emergency situation, proceed to step 2 while the robot is shutting down.
2. Remove the joint cover screws (M3, Torx-T10) and then remove joint cover.
3. Release the brake by pushing the pin on the brake solenoid and move the joint in the desired direction.
4. When finished moving the joint, reengage the brake by releasing the pin on the brake solenoid.
5. Place the cover onto the joint and tighten the joint cover screws.

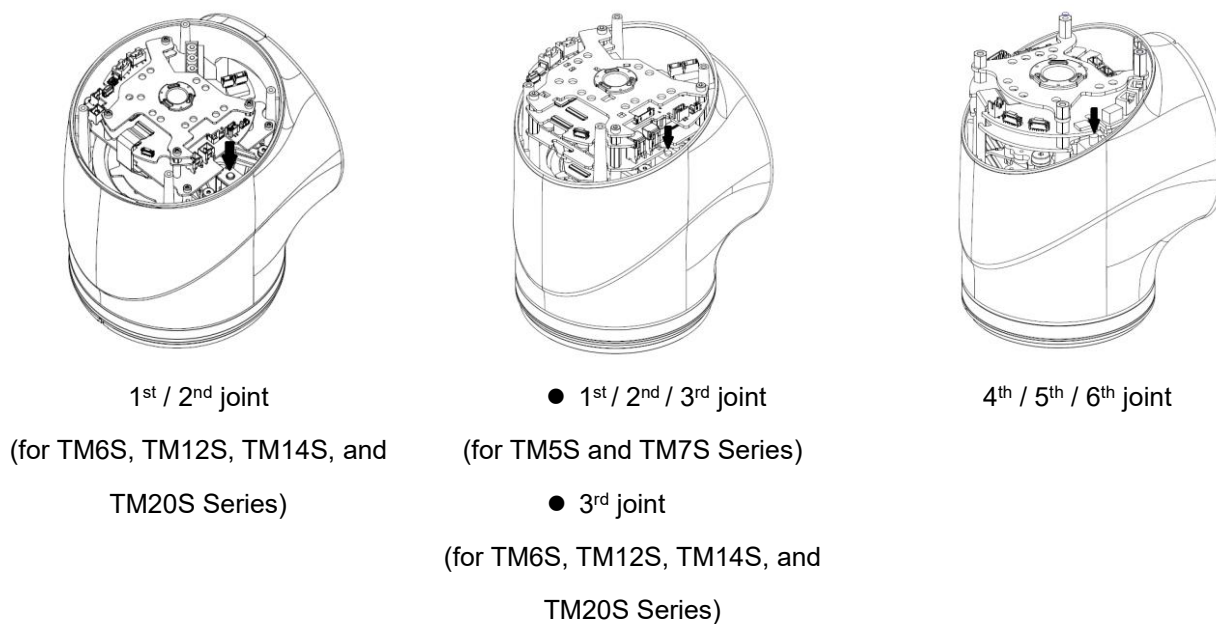


Figure 1: Pin position for brake releasing



### **DANGER:**

There is no force compensation during joint movement without drive power, which means more force is required to move each joint directly against the motor drive.



### **IMPORTANT:**

Always replace the gasket and fasteners after removing any joint cover. Failure to replace these items will degrade the IP65 rating of the product.



**WARNING:**

- Due to gravity, additional supports are recommended when manually releasing the brake.
- When manually moving each robot joint, the movement angle must be within a range of +/- 45°.
- Users should be well trained and pay attention to moving the robot without drive power during any emergency and abnormal situations.

2.11 Labels

The following labels, especially the warning ones, are attached to the locations where specific dangers may occur. Be sure to comply with description and warnings of the labels when operating to avoid accidents. Do not tear, damage, or remove the labels. Be very careful if you need to handle the parts where the labels are attached.




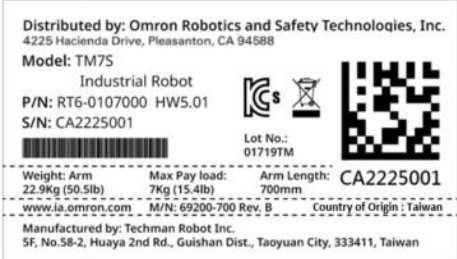
A		Do not put your hand or fingers close to moving parts.
B		Be careful not to be close to the moving parts and nearby areas to avoid impact.
C		<ul style="list-style-type: none"> <li>● Do not touch any internal electric parts to avoid electric shock.</li> <li>● Arc flash hazard, appropriate PPE required. Failure to comply can result in death or injury. Refer to NFPA 70 E.</li> <li>● Risk of fire or electric shock. The door lock is not interlocked with the machine supply circuit disconnect. An unlocking or opening of doors does not de-energize exposed live parts.</li> </ul>
D		Product label

Table 3: Denotation of Labels

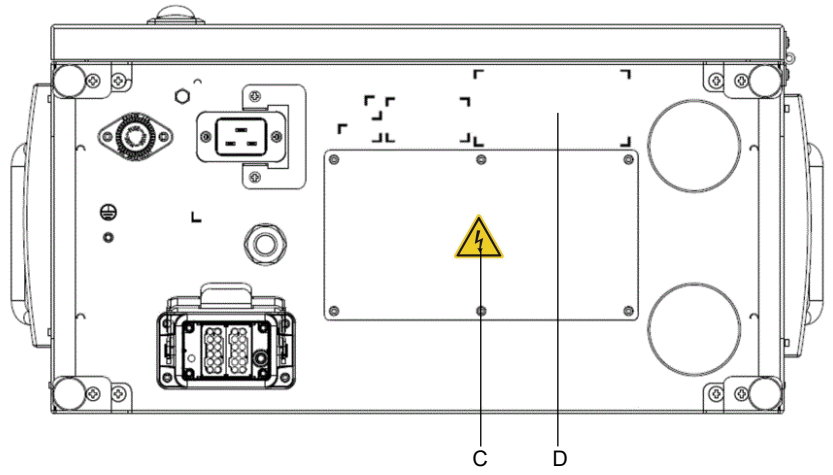
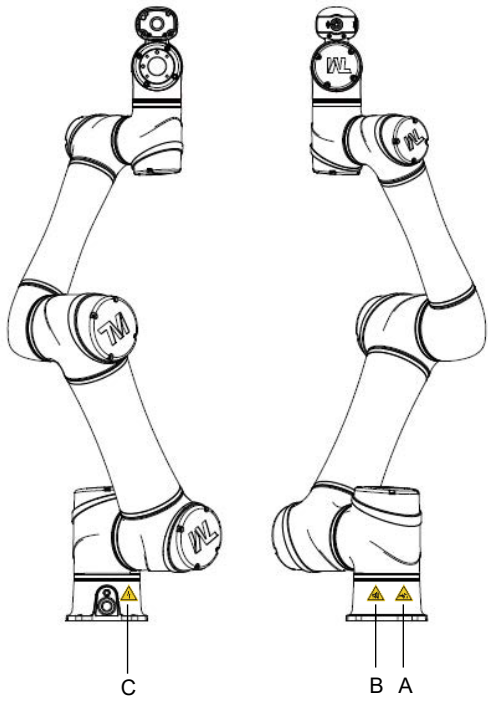


Figure 2: Locations of Labels

### 3. Transportation and Storage

Transport the TM Robot using its original packing materials. If you will need to transport the TM Robot after unpacking, store the packing materials in a dry place. Hold both arms of the TM Robot during transportation. Support the arms while tightening the base screws.

Lift the Control Box by its handles. Store the cables before transportation.



**WARNING:**

Pay attention to your posture when moving the arm and Control Box cartons to avoid back injury. The Corporation will not be liable for any injuries caused during transportation.



**WARNING:**

If the robot has not moved for a period of time, the base oil may be separated and leaked due to the influence of gravity. It is recommended to let the joints of the robot move at a slow speed (less than 10%) for at least 30 minutes every other month to make the base oil circulates effectively in the joints.



**WARNING:**

This product must be shipped and stored in a temperature-controlled environment, within the range -20°C to 60°C (-4°F to 140°F). The recommended humidity is up to 75 percent, non-condensing. It should be shipped and stored in the supplied package, which is designed to prevent damage from normal shock and vibration, You should protect the package from excessive shock and vibration.

The product must always be stored and shipped in an upright position in a clean, dry area that is free from condensation. Do not lay the package on its side or any other non-upright position. This could damage the product.

## 4. System Hardware

### 4.1 Overview

This chapter introduces the mechanical interface of the TM Robot System.

### 4.2 System Overview

TM Robot is made up of the robot arm and Control Box (including the Robot Stick).

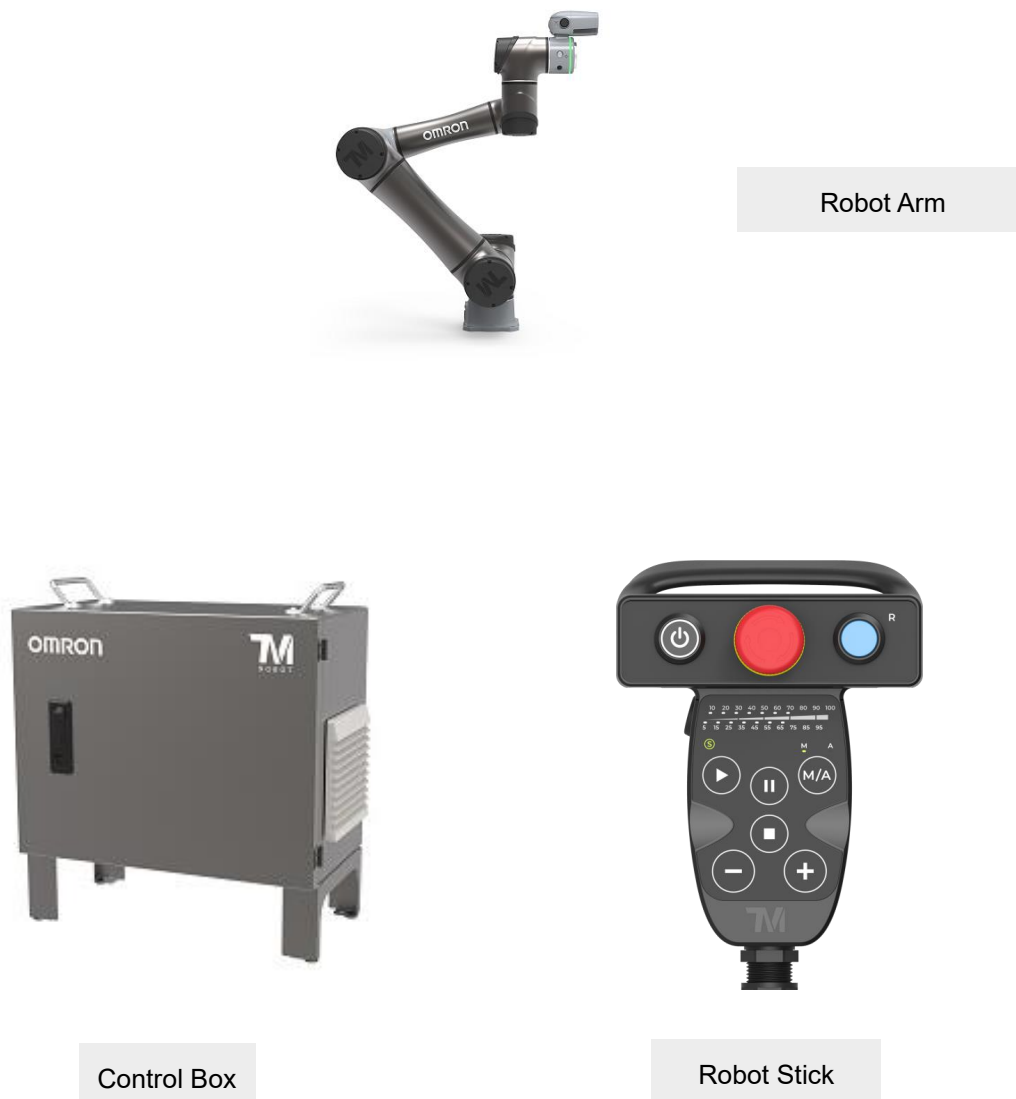


Figure 3: System Overview

## 4.2.1 Robot Arm

### 4.2.1.1 Dimension Drawings of Robot

Shown below is the dimension drawing of the robot

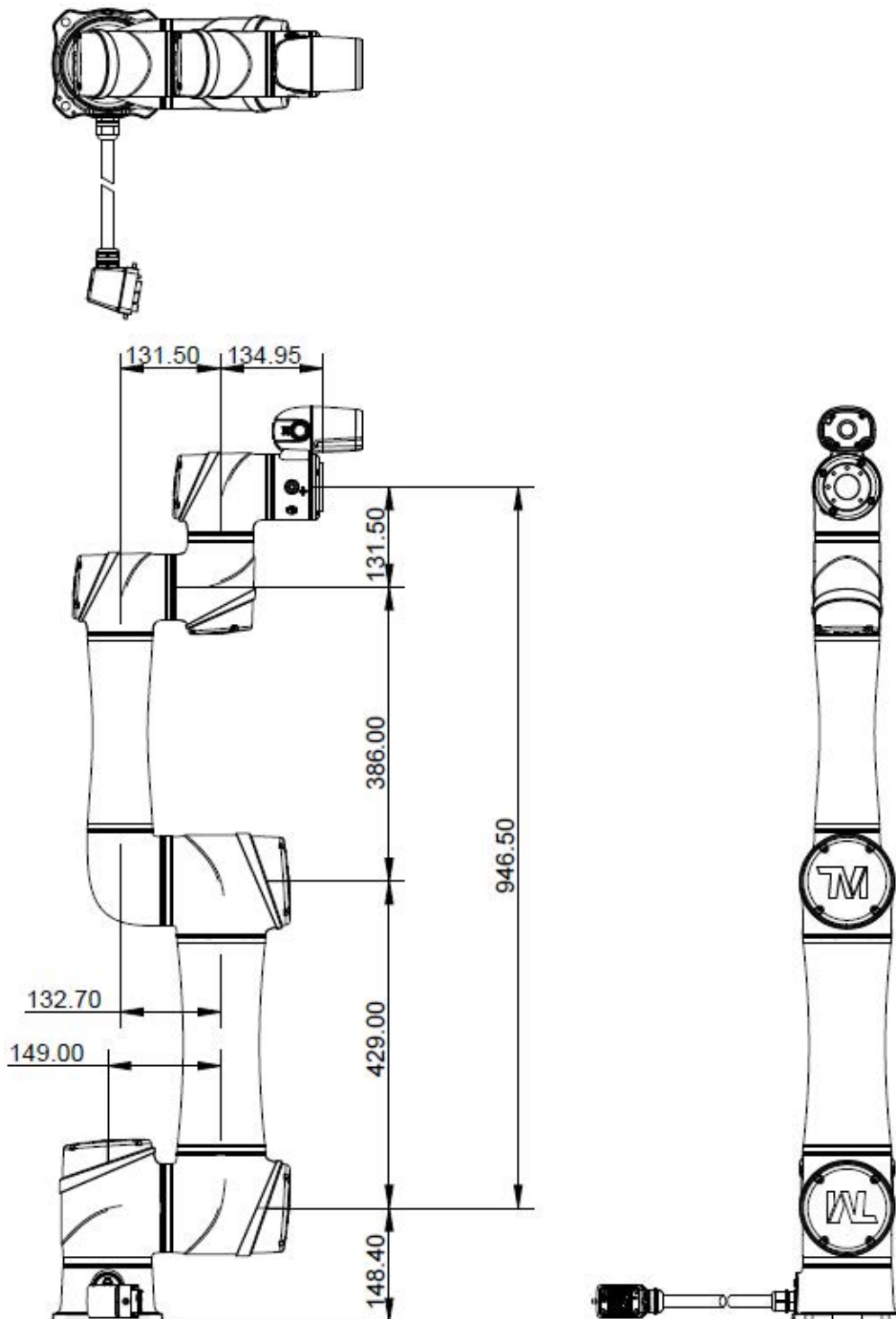


Figure 4: Dimension of TM5S / TM5S-M / TM5S-NM

\*All measures are in mm.

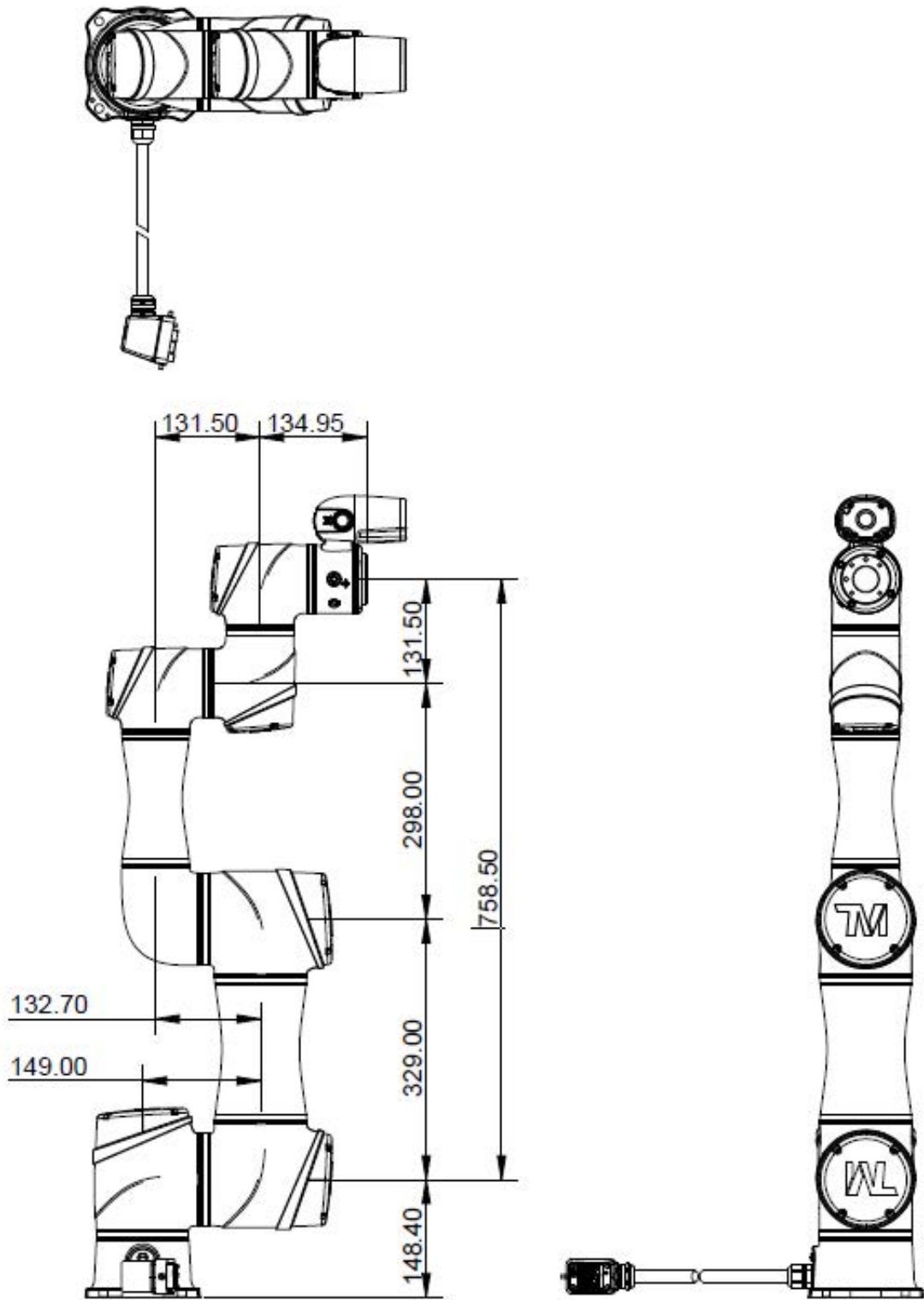


Figure 5: Dimension of TM7S / TM7S-M / TM7S-NM

\*All measures are in mm.

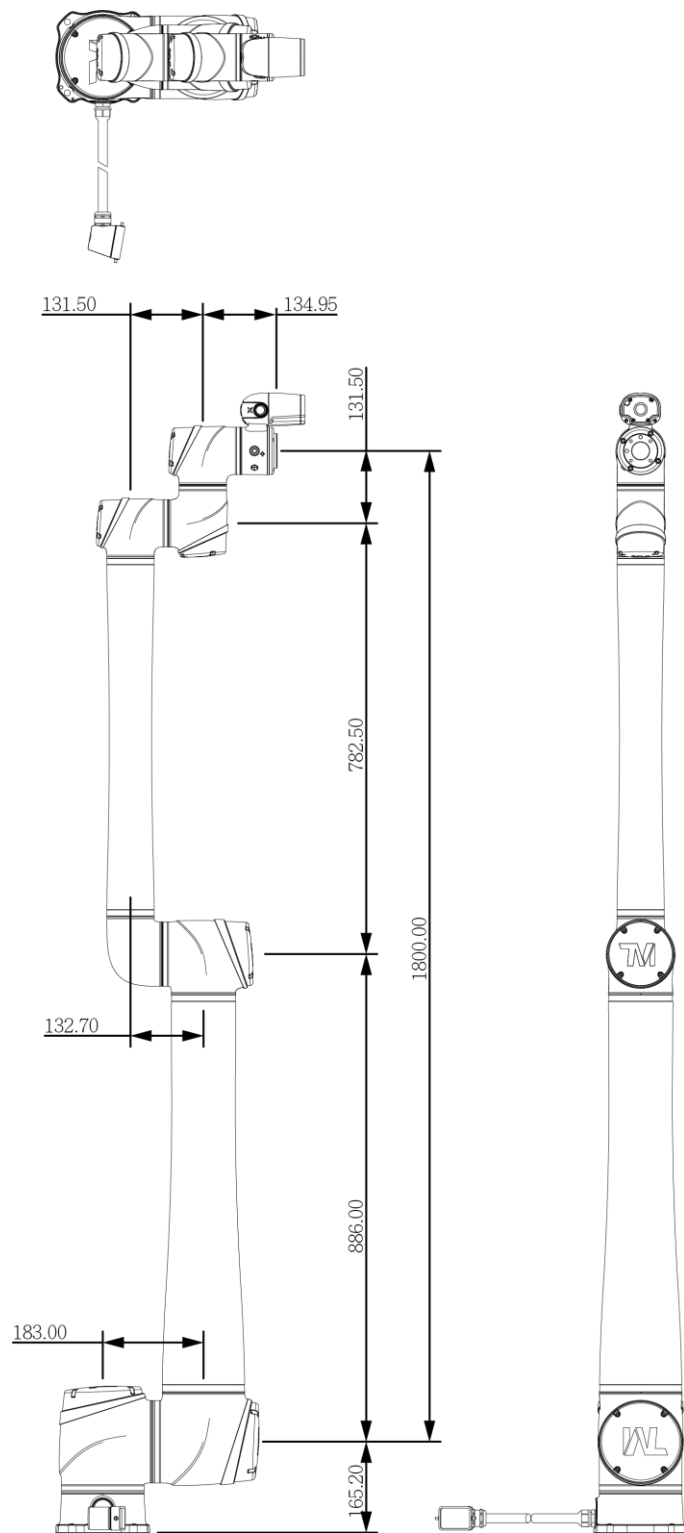


Figure 6: Dimension of TM6S / TM6S-M / TM6S-NM

\*All measures are in mm.

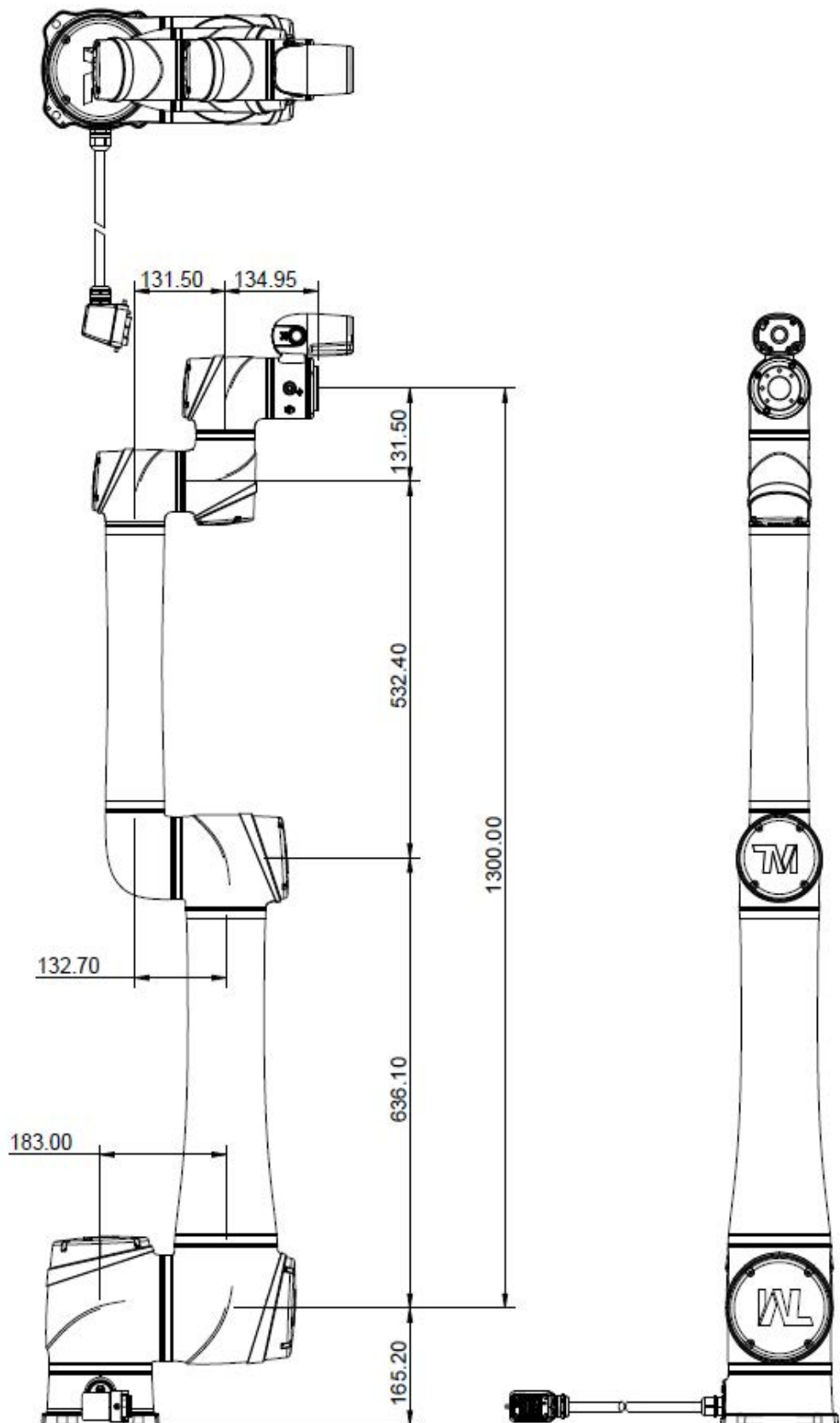


Figure 7: Dimension of TM12S / TM12S-M / TM12S-NM / TM20S / TM20S-NM

\*All measures are in mm.

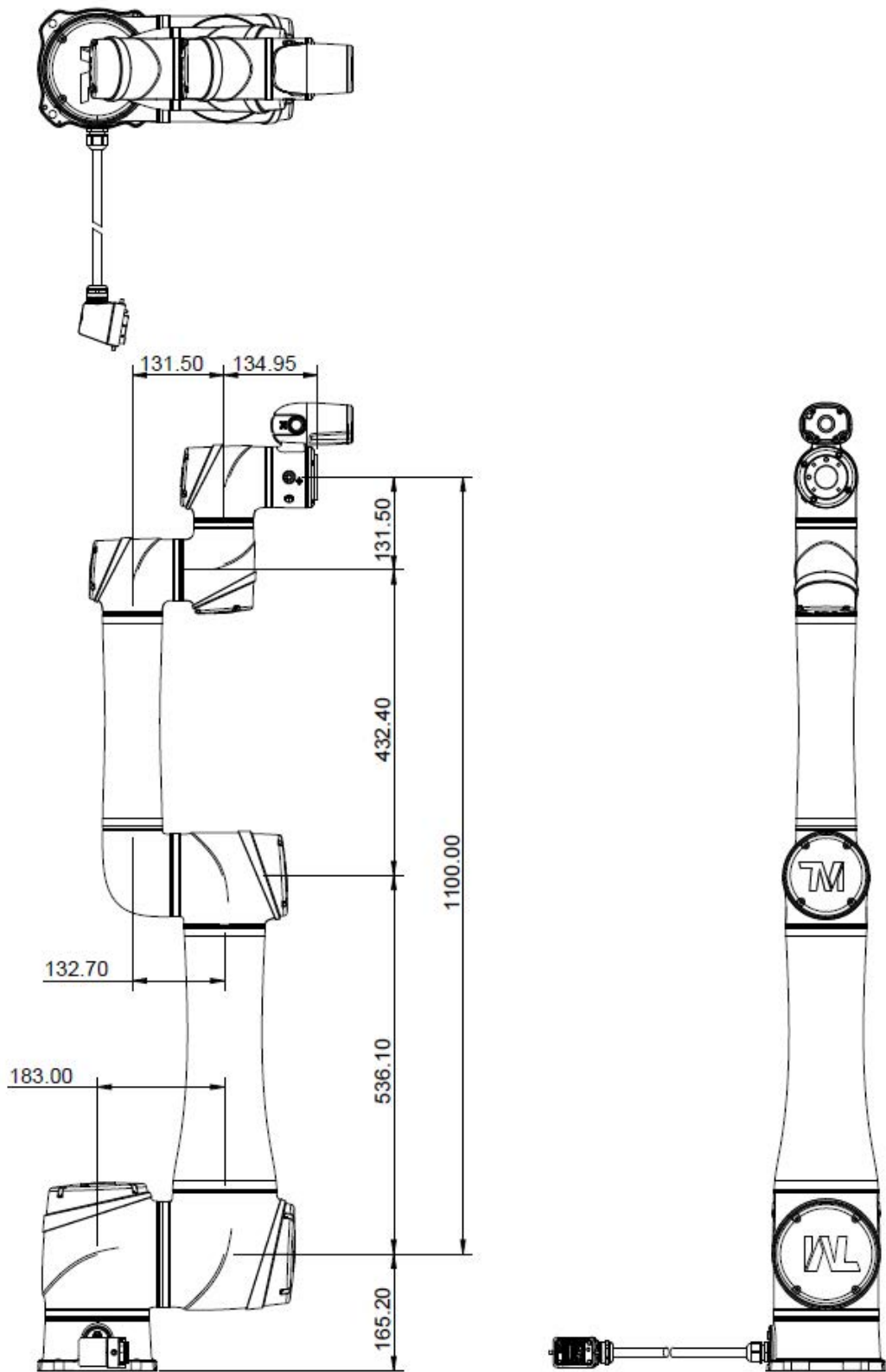


Figure 8: Dimension of TM14S / TM14S-M / TM14S-NM

\*All measures are in mm.

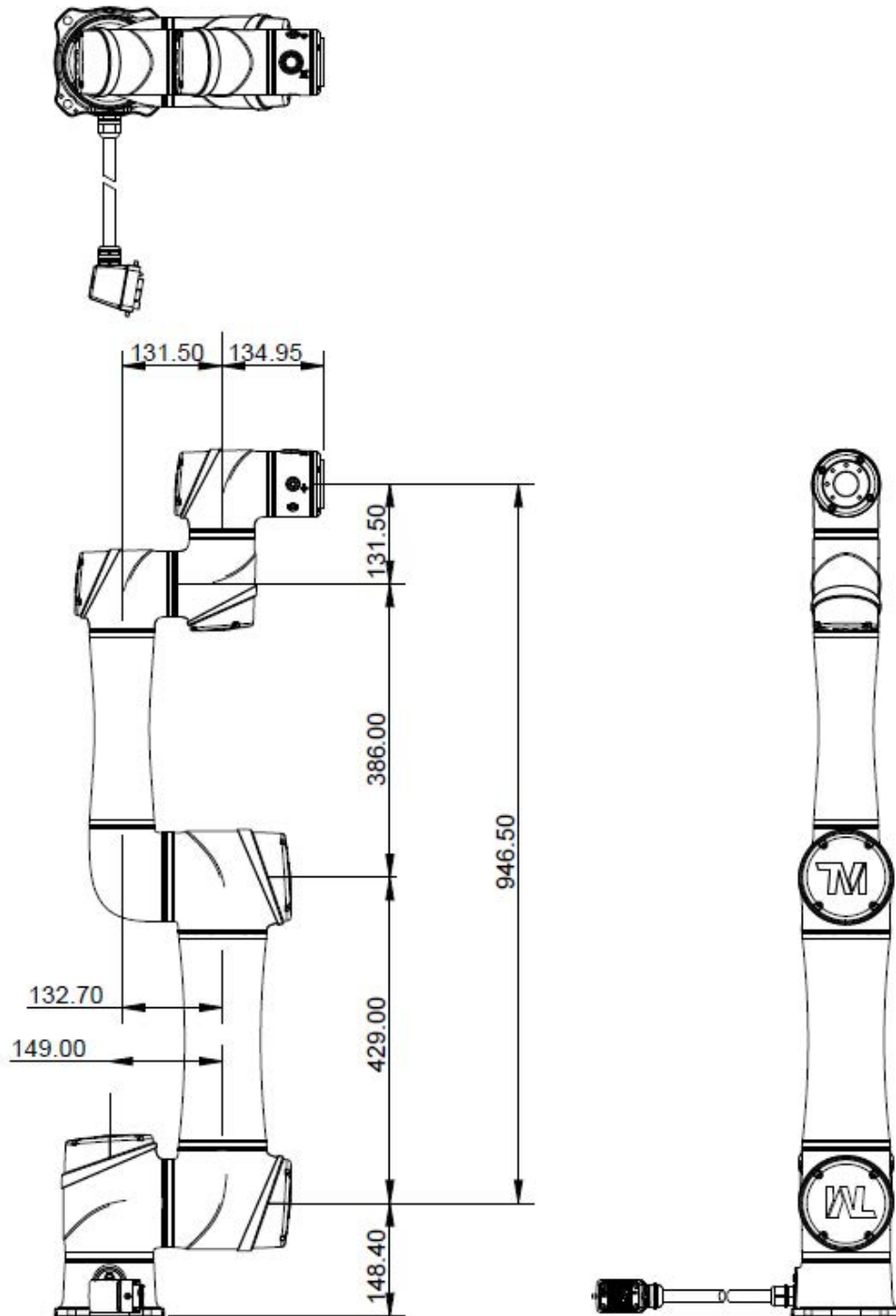


Figure 9: Dimension of TM5S-X / TM5S-MX / TM5S-NMX

\*All measures are in mm.

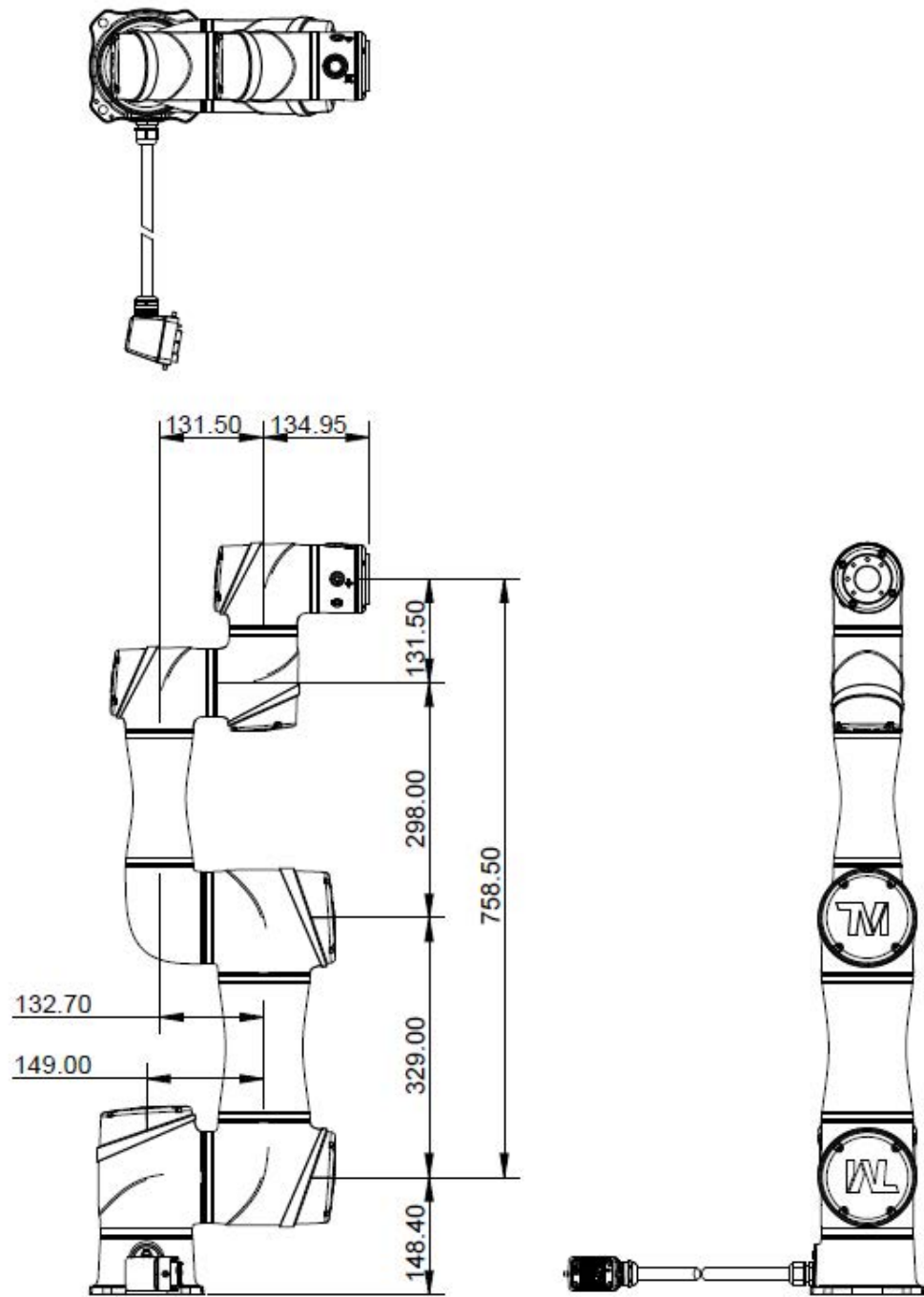


Figure 10: Dimension of TM7S-X / TM7S-MX / TM7S-NMX

\*All measures are in mm.

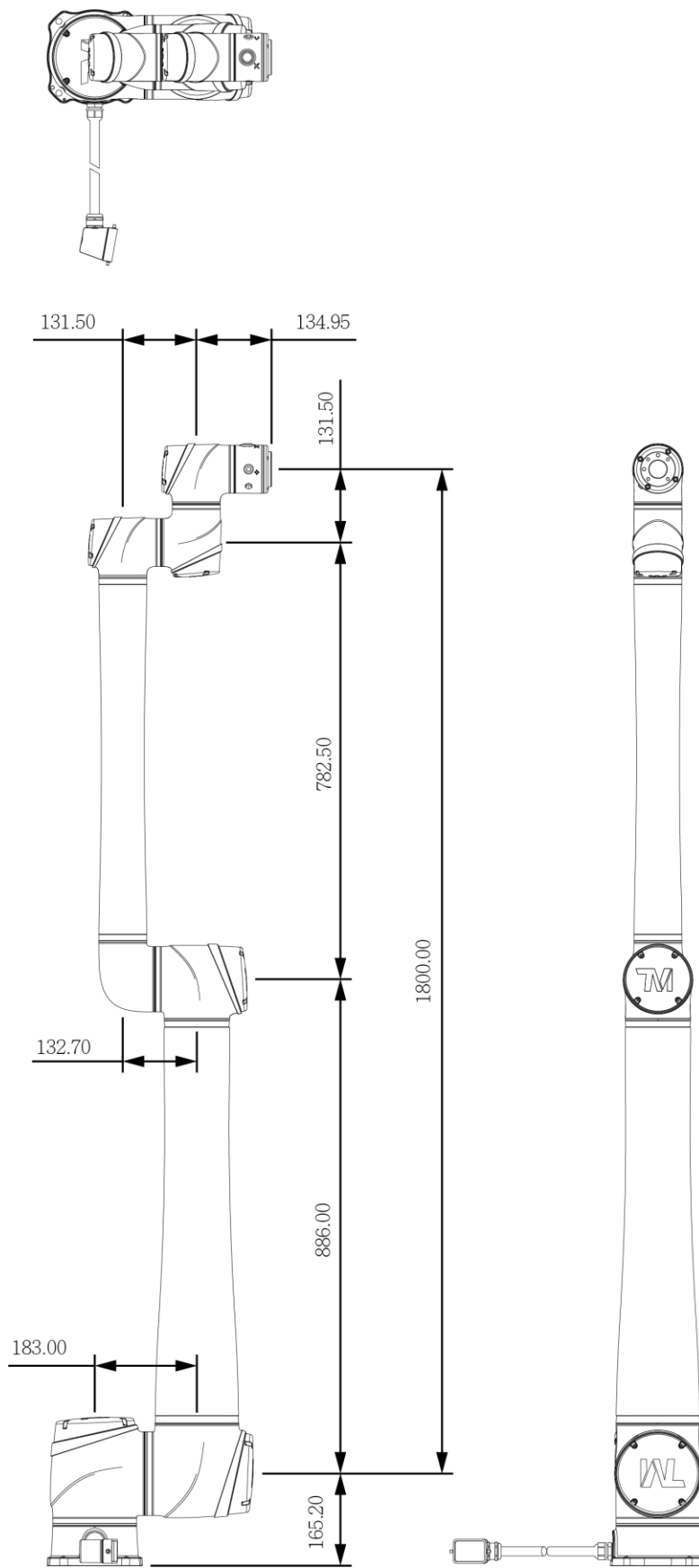


Figure 11: Dimension of TM6S-X / TM6S-MX / TM6S-NMX

\*All measures are in mm.

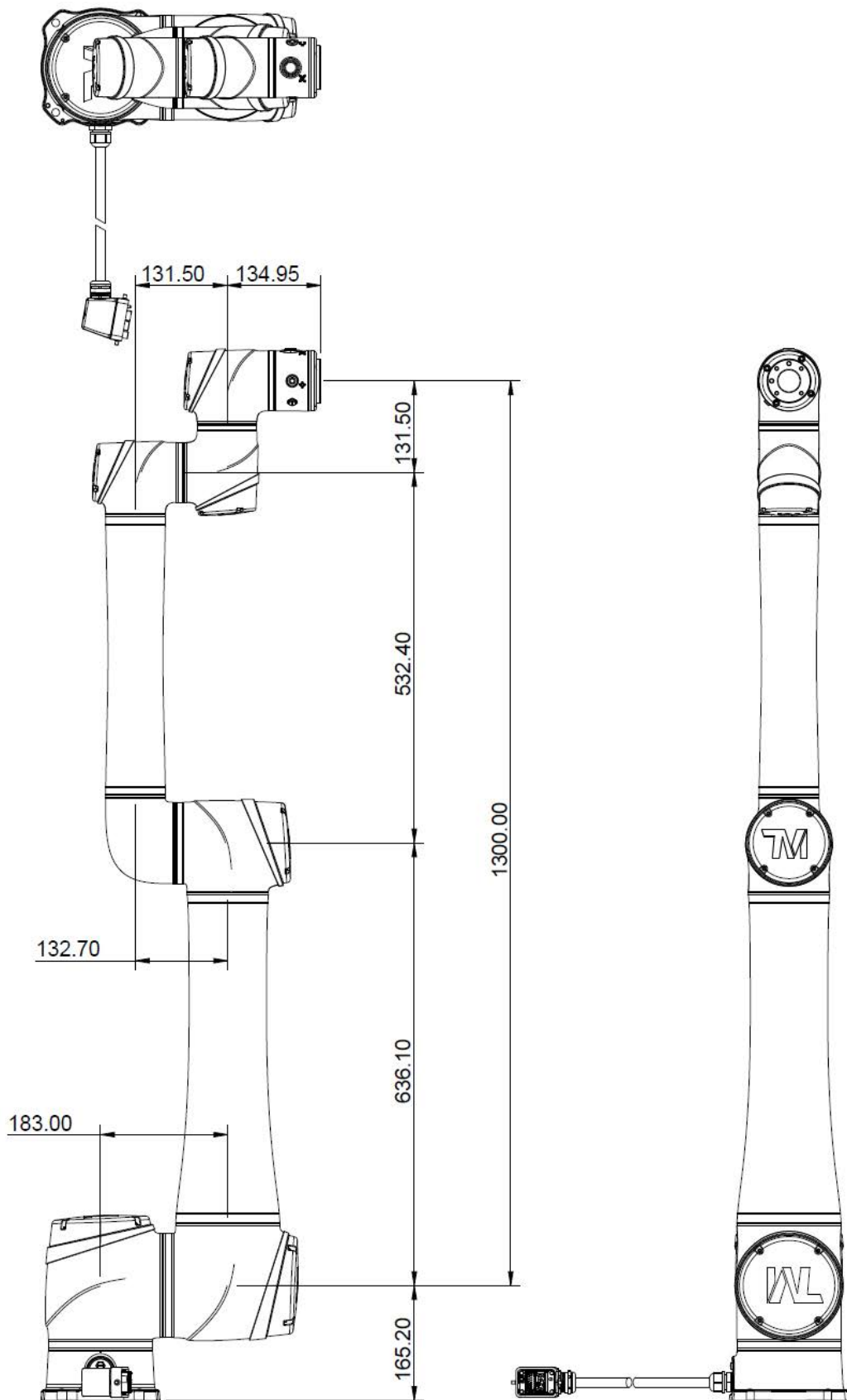


Figure 12: Dimension of TM12S-X / TM20S-X / TM12S-MX / TM12S-NMX / TM20S-NMX

\*All measures are in mm.

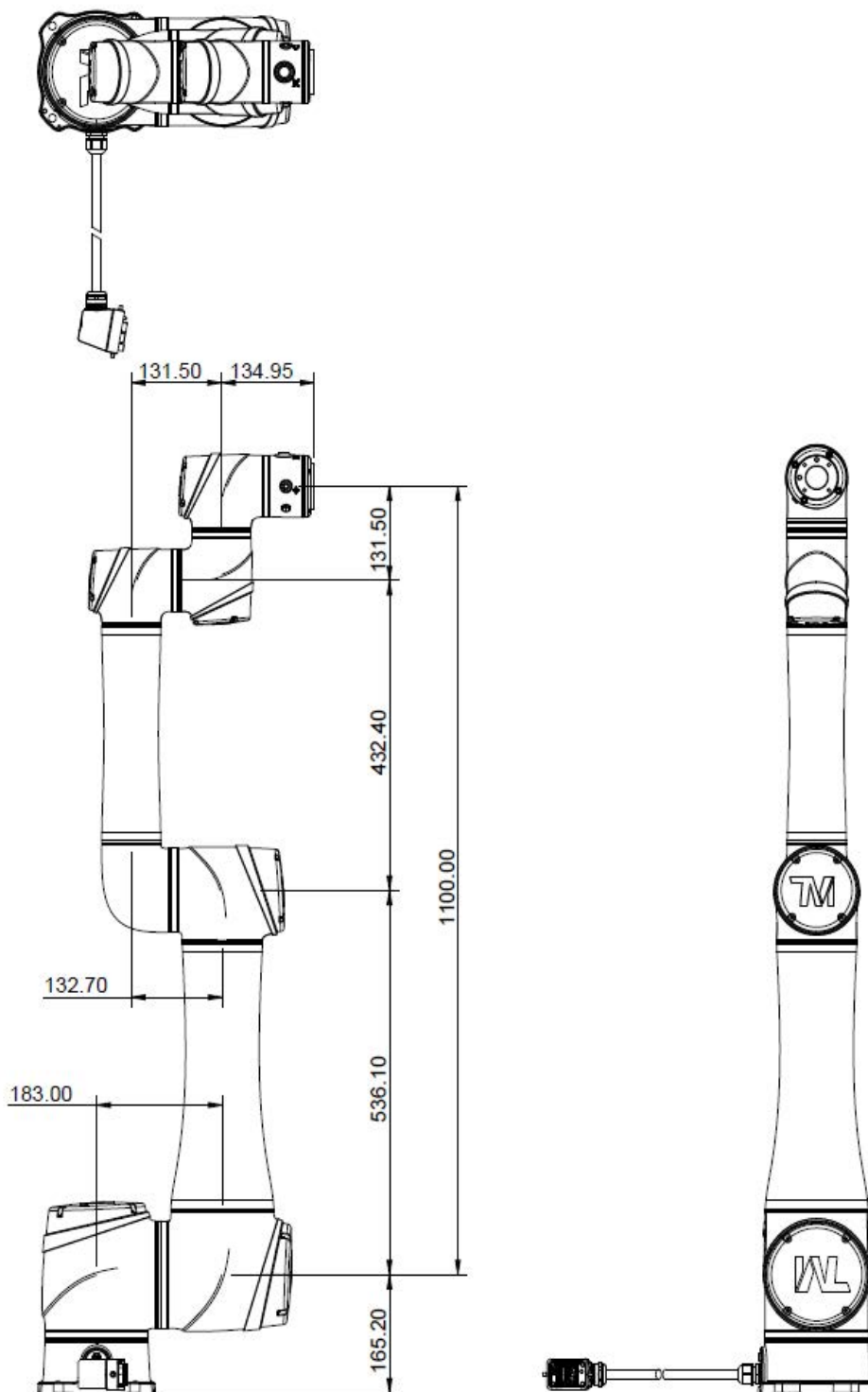
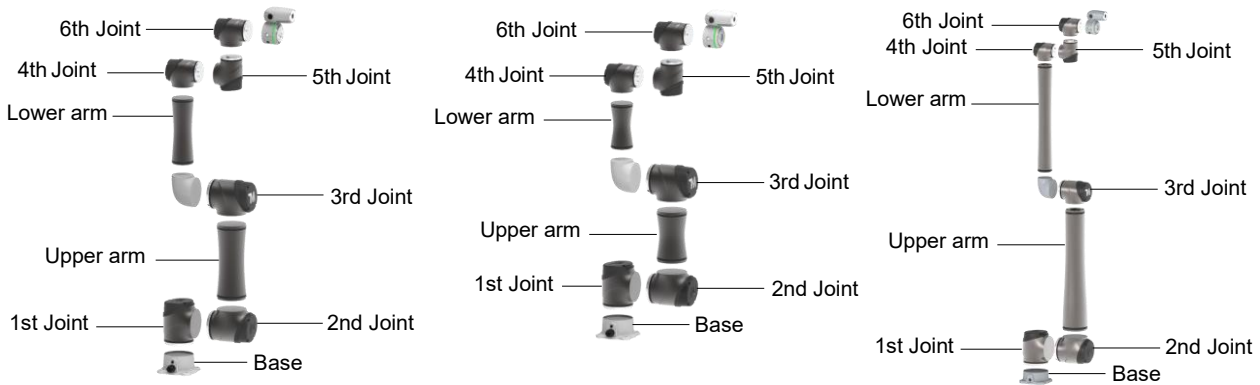


Figure 13: Dimension of TM14S-X / TM14S-MX / TM14S-NMX

\*All measures are in mm.

#### 4.2.1.2 Robot Assembly Diagram

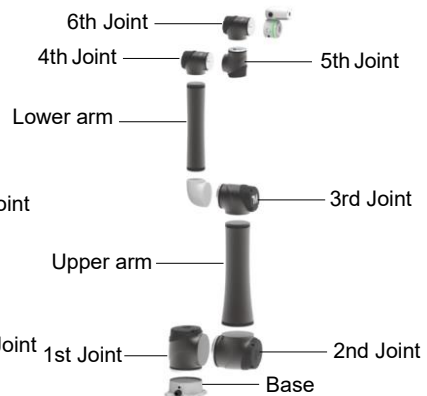
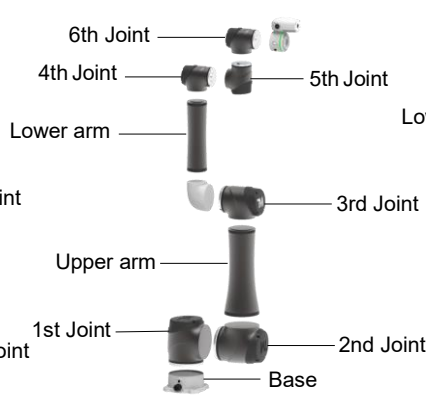
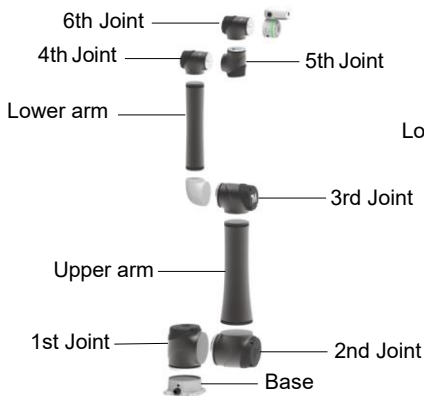
Shown below is an illustration of the robot components. To avoid safety risks, do not attempt to disassemble any component on your own. Contact your local corporation support for any service request.



TM5S / TM5S-M / TM5S-NM

TM7S / TM7S-M / TM7S-NM

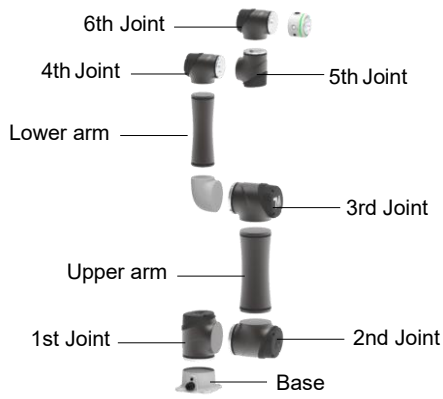
TM6S / TM6S-M / TM6S-NM



TM12S / TM12S-M /  
TM12S-NM

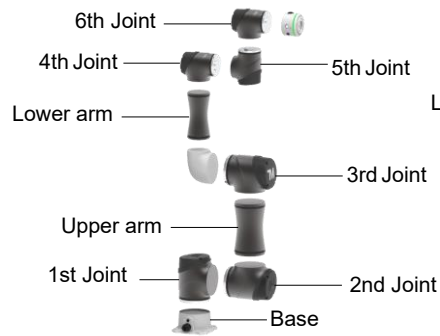
TM14S / TM14S-M /  
TM14S-NM

TM20S / TM20S-NM



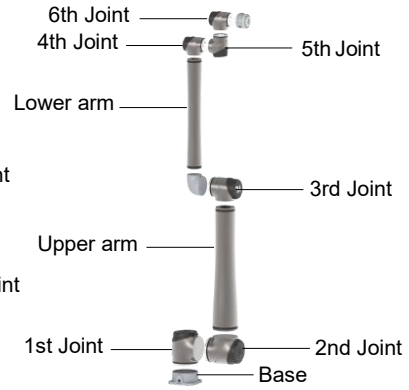
TM5S-X / TM5S-MX /

TM5S-NMX



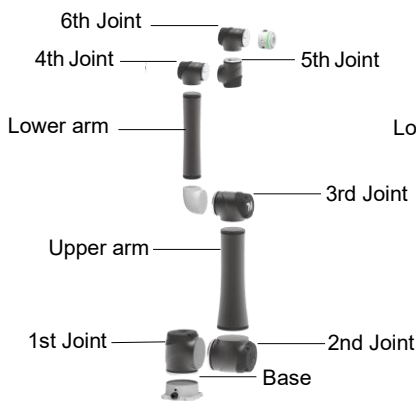
TM7S-X / TM7S-MX /

TM7S-NMX



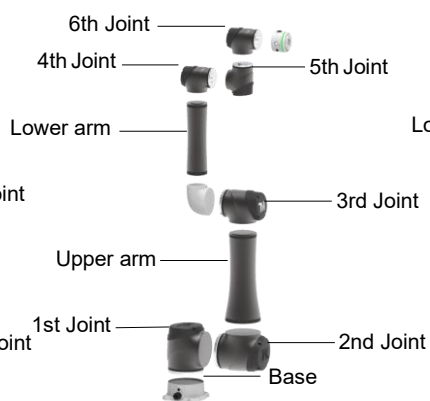
TM6S-X / TM6-MX /

TM6S-NMX



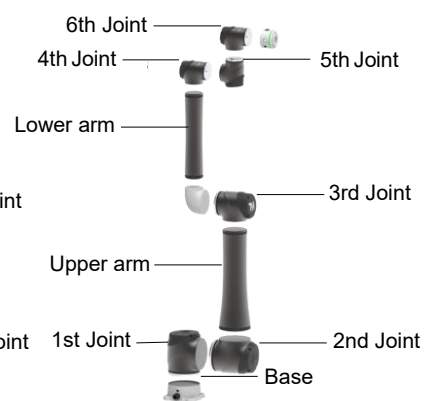
TM12S-X / TM12S-MX /

TM12S-NMX



TM14S-X / TM14S-MX /

TM14S-NMX



TM20S-X / TM20S-NMX

#### 4.2.1.3 Range of Motion

The working spherical (radius) range from the base is 946 mm for the TM5S series, 758 mm for the TM7S series, 1800 mm for the TM6S series, 1300 mm for the TM12S series and TM20S series, and 1100 mm for the TM14S series.

#### **DANGER:**

With the exception of an individual being in full control of robot motion during hand-guiding, personnel shall be outside the safeguarded space when the robot is in motion while in manual mode (i.e. teaching).



The emergency stop on the robot stick must be readily accessible during manual mode. At least one emergency switch is installed outside of the motion range of the robot. When no motion limit is set for the robot, the motion range of the robot is equal to the maximum motion range of the robot arm. You can set a motion limit to avoid the situation whereby all operators have to be outside of the maximum motion range of the robot arm.

The robot stick should be placed in an area that the robot cannot reach. Users should also make sure that the movement of the robot will not be within any area where personnel will enter to press any buttons on the robot stick.

TM5S Series Movement Range Diagram

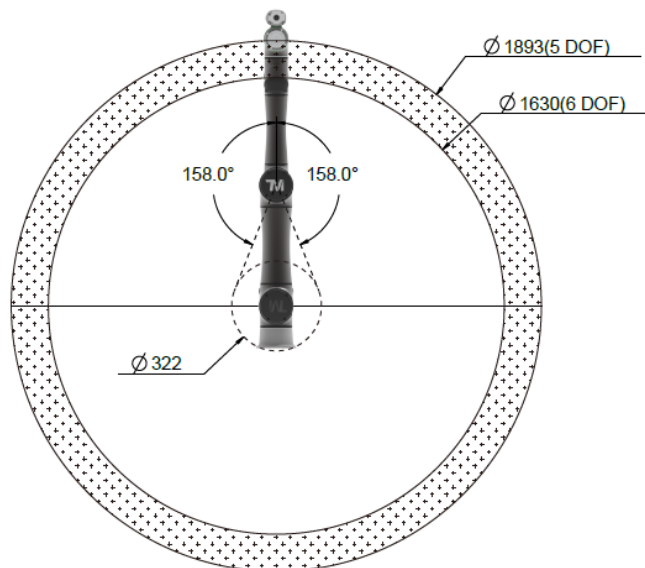


Figure 14: Side View of TM5S Series Movement Range Diagram

\*All measures are in mm.

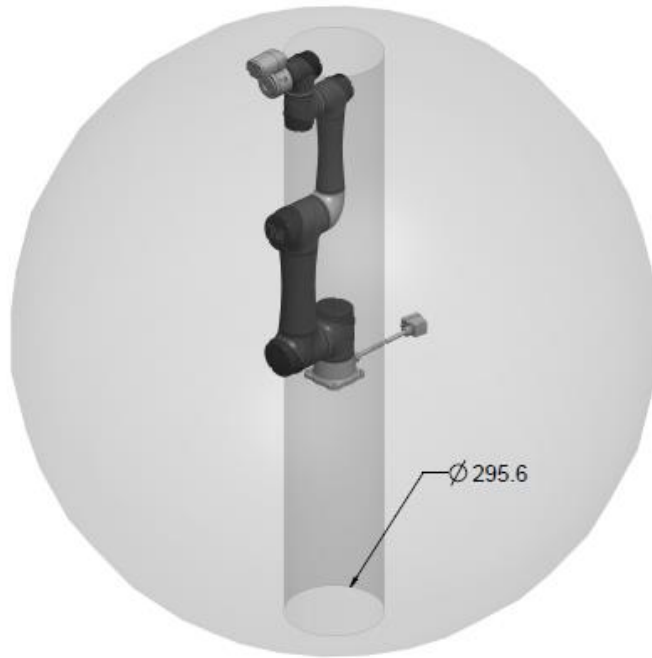
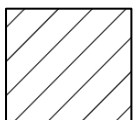
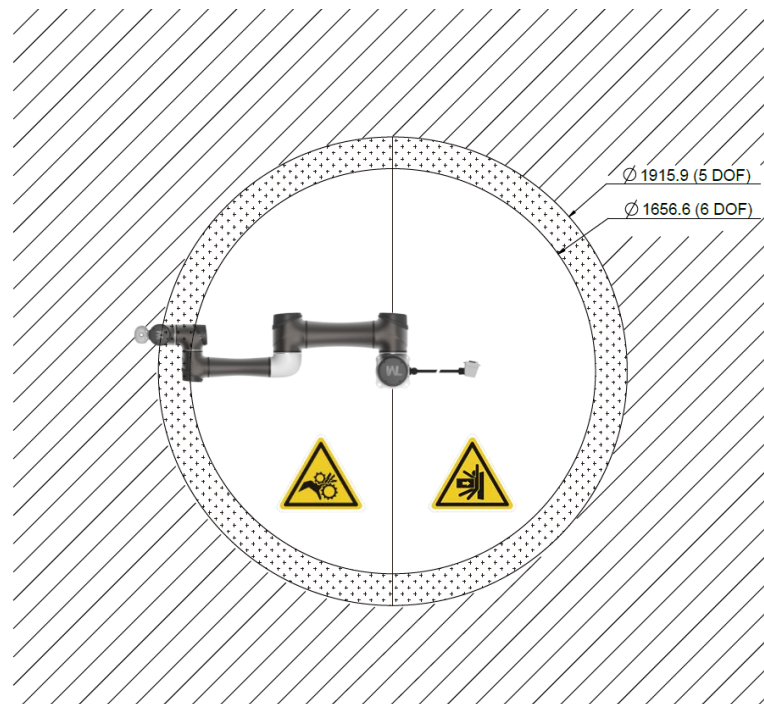


Figure 15: Pictorial view of TM5S Series Movement Range Diagram



Operator  
Position



Warning: Risk of crushing  
within the operating area of  
the arm.



Warning: Risk of collision  
within the operating area of the  
arm.

Figure 16: Top View of TM5S Series Movement Range

\*All measures are in mm.

TM7S Series Movement Range

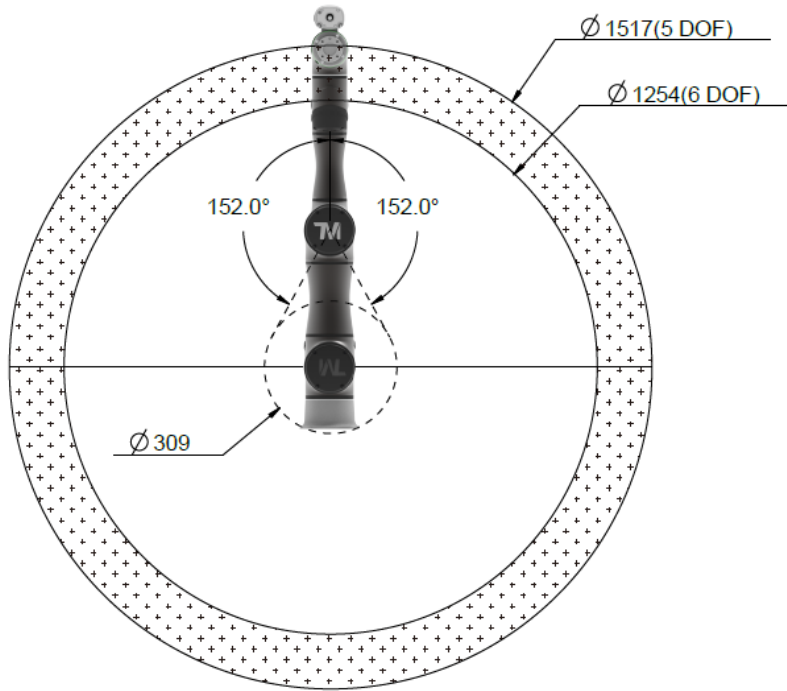


Figure 17: Side View of TM7S Series Movement Range Diagram  
\*All measures are in mm.

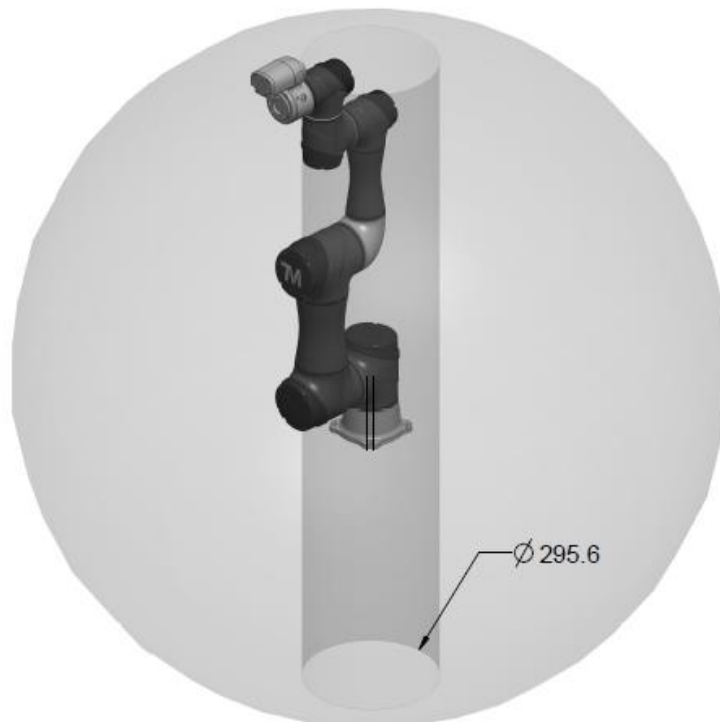
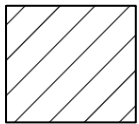
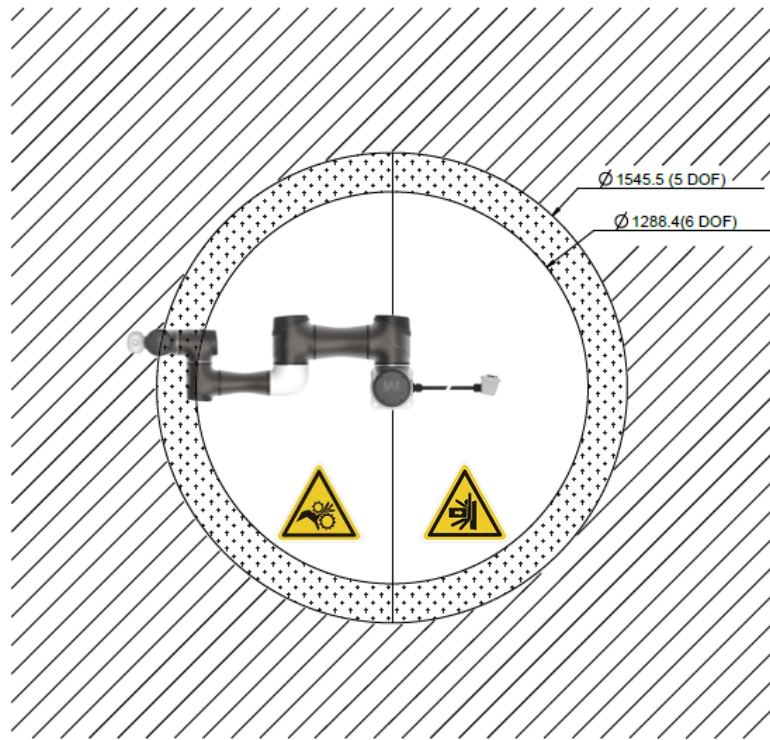


Figure 18: Pictorial View of TM7S Series Movement Range



Operator  
Position



Warning: Risk of crushing within  
the operating area of the arm.



Warning: Risk of collision within  
the operating area of the arm.

Figure 19: Top View of TM7S Series Movement Range

\*All measures are in mm.

### TM6S Series Movement Range Diagram

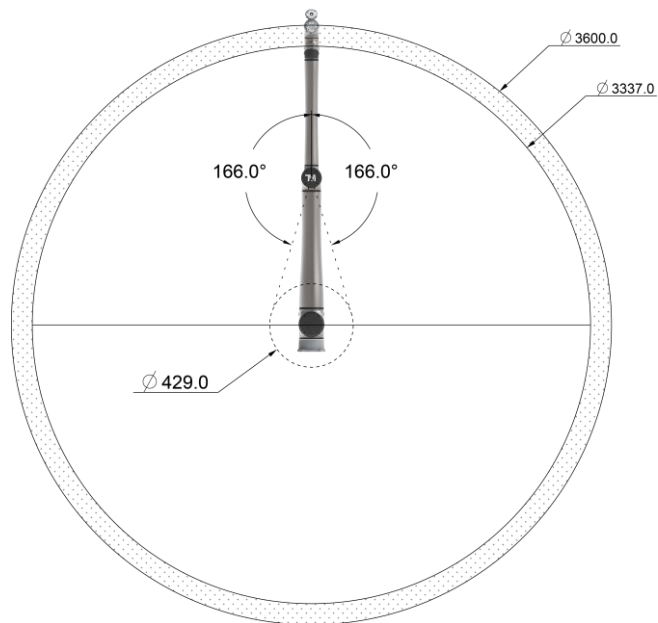
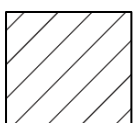
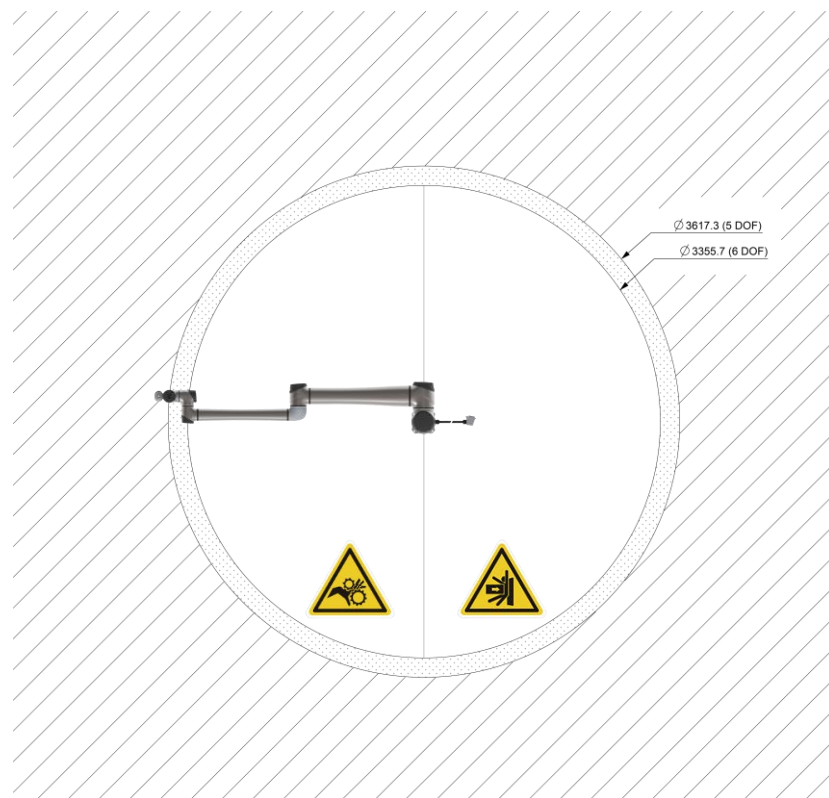


Figure 20: Side View of TM6S Series X Movement Range Diagram

\*All measures are in mm.



Figure 21: Pictorial view of TM6S Series Movement Range Diagram



Operator  
Position



Warning: Risk of crushing within  
the operating area of the arm.



Warning: Risk of collision within  
the operating area of the arm.

Figure 22: Top View of TM6S Series Movement Range

\*All measures are in mm.

TM12S / TM20S Series Movement Range Diagram

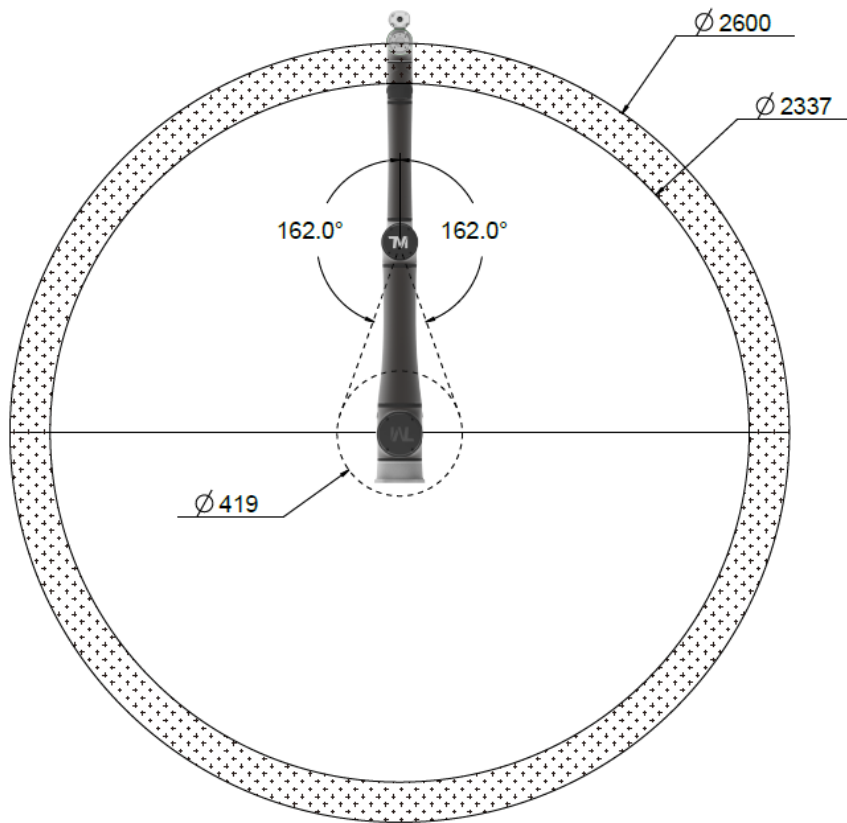


Figure 23: Side View of TM12S / TM20S Series Movement Range Diagram

\*All measures are in mm.

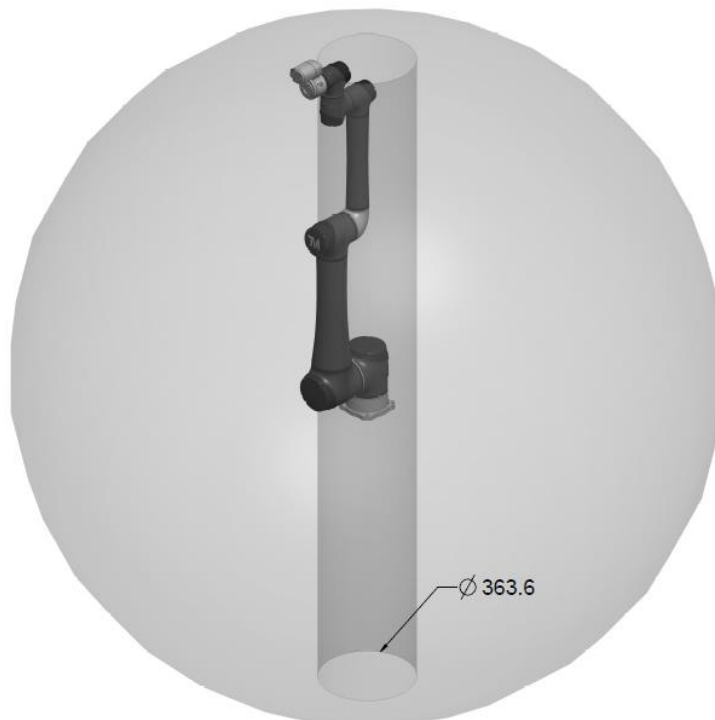
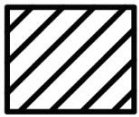
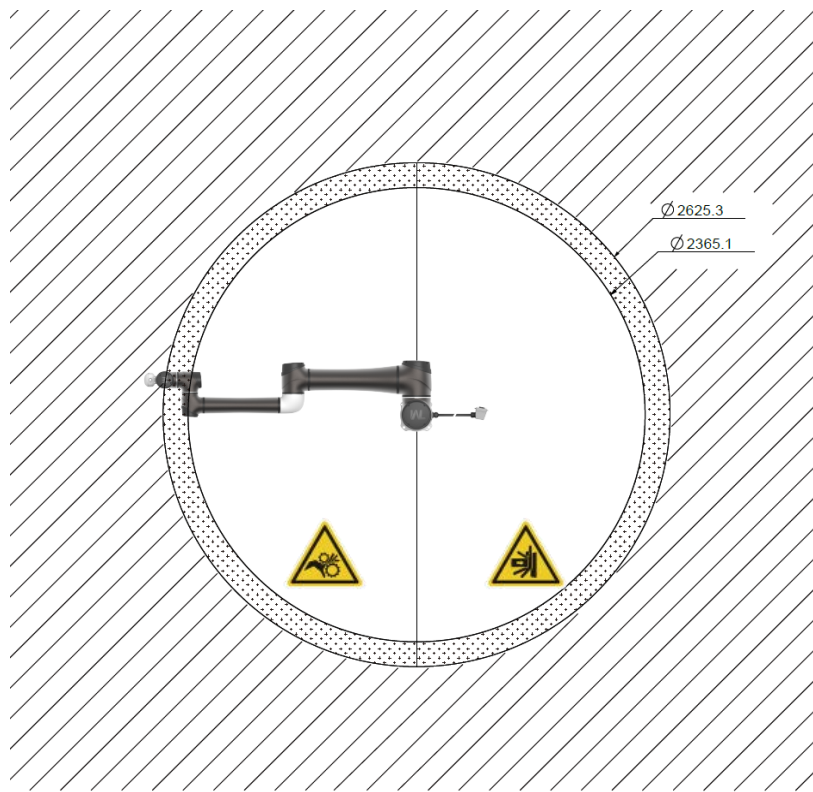


Figure 24: Pictorial view of TM12S / TM20S Series Movement Range Diagram



Operator Position



Warning: Risk of crushing within the operating area of the arm.



Warning: Risk of collision within the operating area of the arm.

Figure 25: Top view of TM12S / TM20S Series Movement Range Diagram

\*All measures are in mm.

TM14S Series Movement Range Diagram

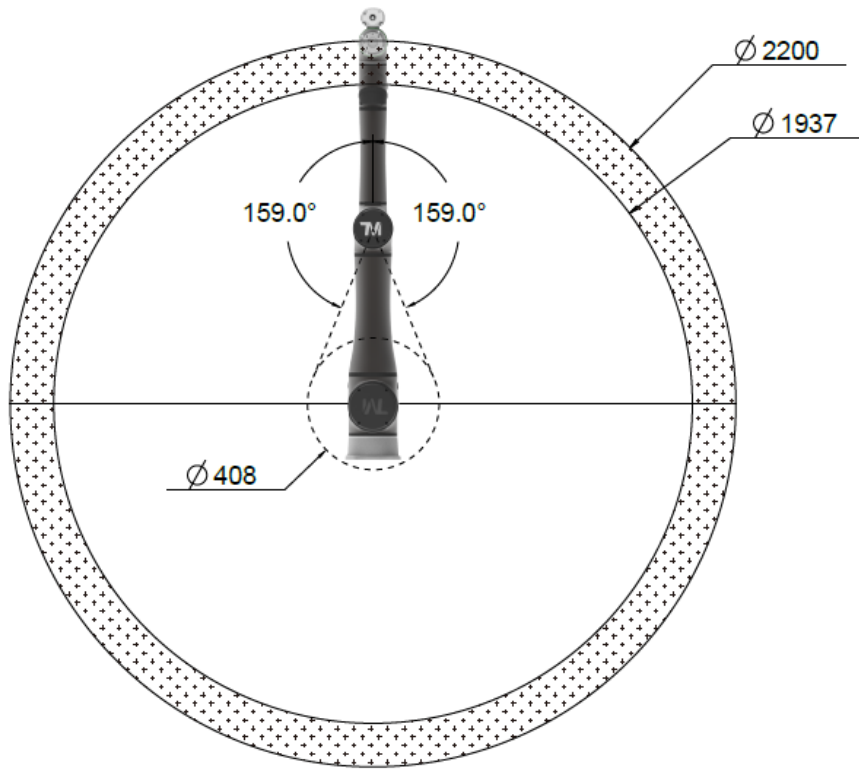


Figure 26: Side view of TM14S Series Movement Range Diagram

\*All measures are in mm.

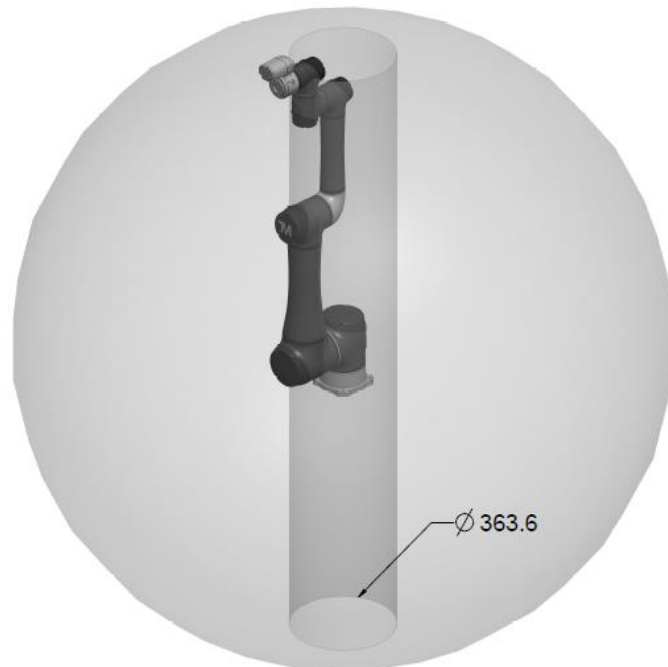
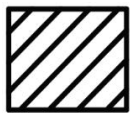
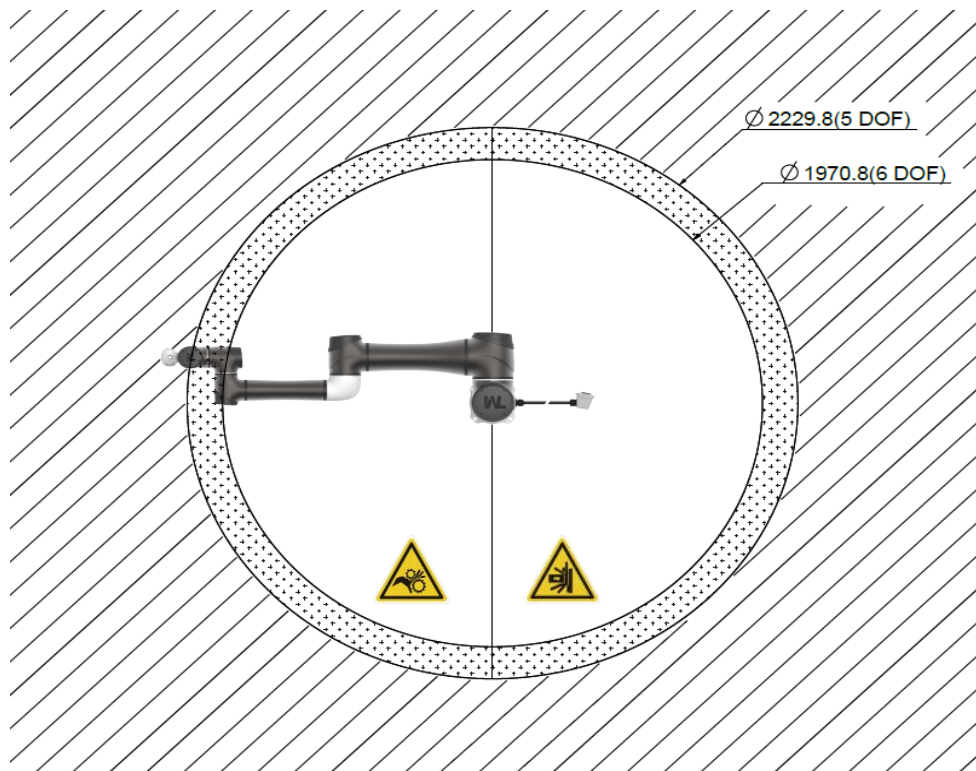


Figure 27: Pictorial view of TM14S Series Movement Range Diagram



Operator



Warning: Risk of crushing within



Warning: Risk of collision within the operating area of the arm.

Figure 28: Top View of TM14S Series Movement Range Diagram

\*All measures are in mm.

#### 4.2.1.4 Payload and Torque

The maximum allowed payload of the robot arm is related to its center of gravity offset, which is defined as the distance from the center point of the robot end of the flange to the payload's center of gravity.

The following figure shows the relationship between payload and the center of gravity offset:

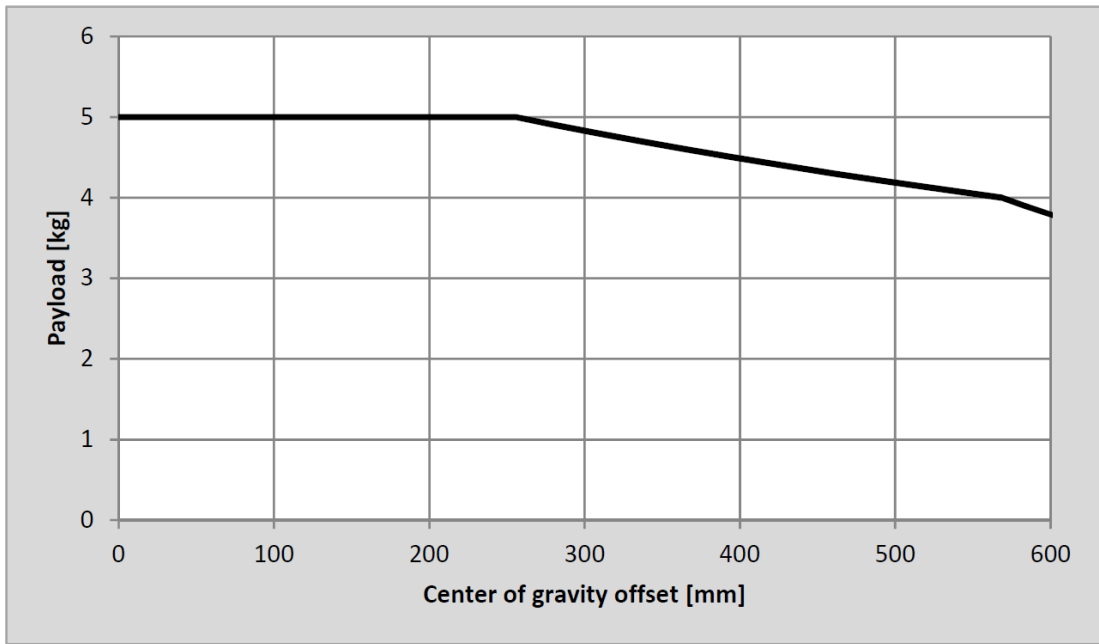


Figure 29: Relationship between Payload and the Center of Gravity Offset in TM5S Series

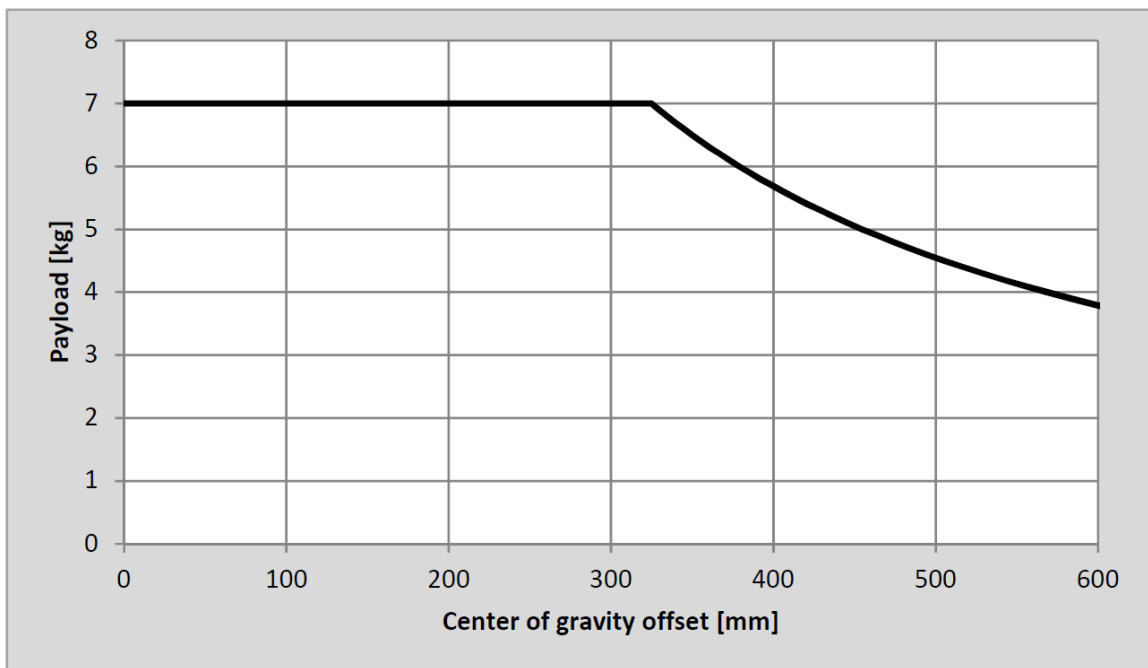


Figure 30: Relationship between Payload and the Center of Gravity Offset in TM7S Series

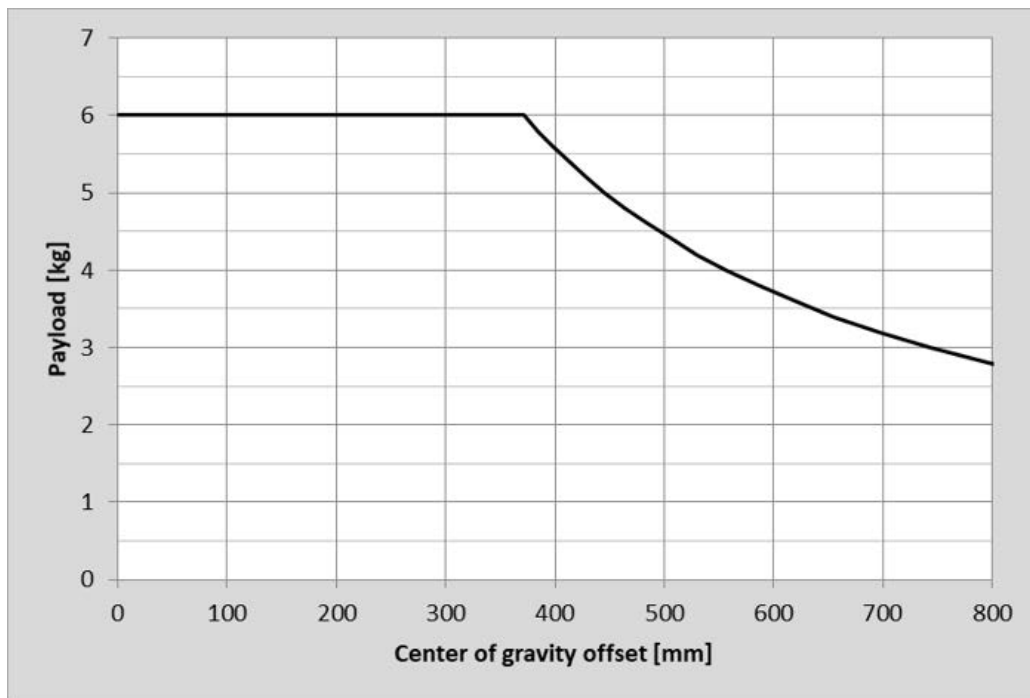


Figure 31: Relationship between Payload and the Center of Gravity Offset in TM6S Series

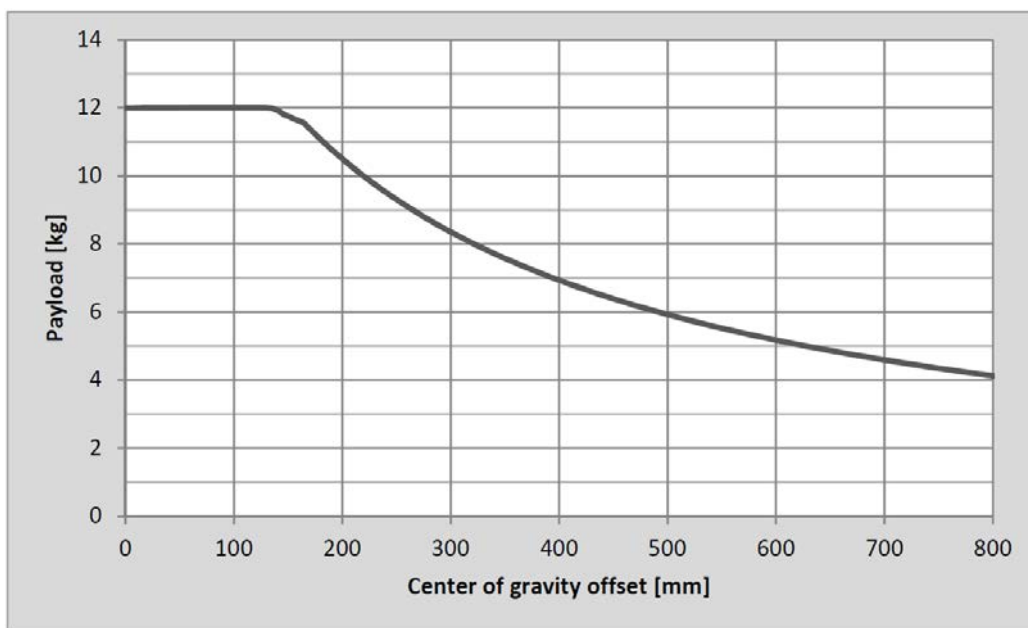


Figure 32: Relationship between Payload and the Center of Gravity Offset in TM12S Series

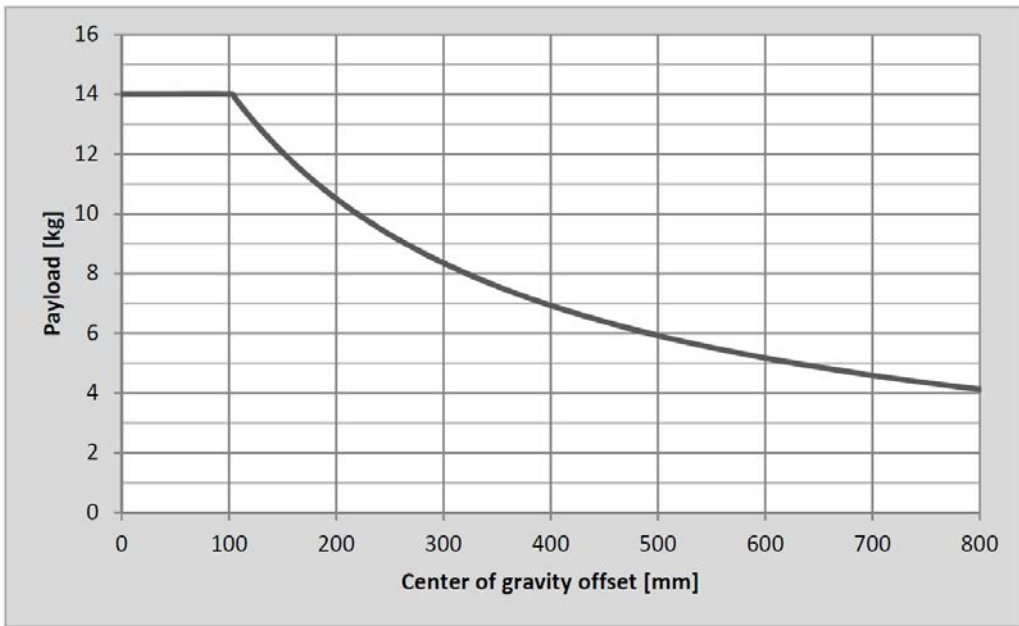


Figure 33: Relationship between Payload and the Center of Gravity Offset in TM14S Series

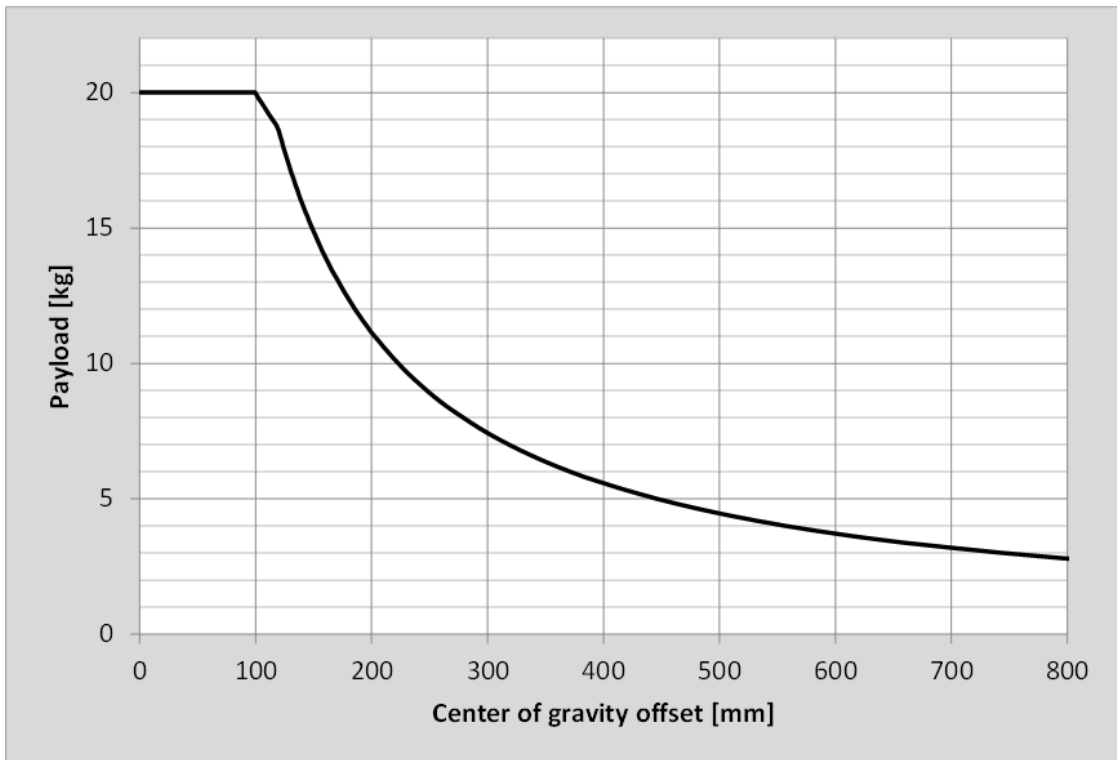


Figure 34: Relationship between Payload and the Center of Gravity Offset in TM20S / TM20S-X

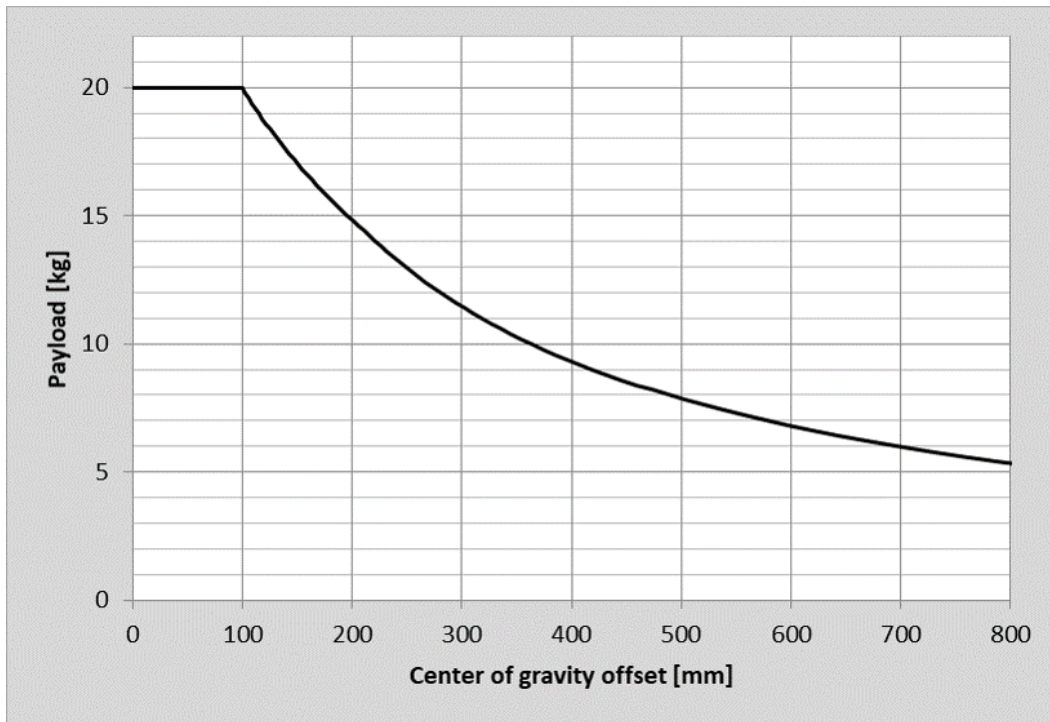


Figure 35: Relationship between Payload and the Center of Gravity Offset in TM20S-NMX/ TM20S-NM

Refer the table below for the rated torque and the limit of repeated peak torque of the robot. Exceeding torque may reduce the life of the robot or damage the robot.

Model	TM5S & TM7S Series		TM6S & TM12S Series		TM14S Series		TM20S / TM20S-X		TM20S-NM / TM20S-NMX	
	Rated torque	Limit for repeated peak torque	Rated torque	Limit for repeated peak torque	Rated torque	Limit for repeated peak torque	Rated torque	Limit for repeated peak torque	Rated torque	Limit for repeated peak torque
J1	108	157	216	353	216	353	281	459	281	459
J2	108	157	216	353	216	353	281	484	281	484
J3	108	157	108	157	108	157	140	229	140	229
J4	39	54	39	54	39	54	51	70	51	70
J5	39	54	39	54	39	54	39	54	39	54
J6	22	34	22	34	22	34	22	34		

Unit: Nm

Table 4: Rated Torque and Limit for Repeated Peak Torque of TM5S, TM7S, TM6S, TM12S, TM14S, and TM20S Robot Series

**WARNING:**

Use the total weight of the end-effector and the payload to stay within the payload rating of the robot. Ensure that the system never exceeds that maximum payload. Users should perform a full risk assessment that includes the end-effector and payload samples to prevent hazards such as shocks, vibrations, collisions, entanglements, stabbings, and piercings to secure the entire system.

#### 4.2.1.5 Robot Arm Installation

The robot can be secured to another surface with the use of four M10 screws and washers. The mounting pattern is shown below. The recommended tightening torque is 40 Nm.

Optional - Two openings for 6 mm position pins are provided for more secure position mounting.

Ensure the strength of the mounting surface and its surround area before installations for upside down mounting and side mounting such as on the ceiling or the wall.

**DANGER:**

1. The TM Robot must be securely and tightly screwed down before use. The strength of the mounting surface must be sufficient.  
When operating at high speed, the robot can generate up to 350 N (for TM5S and TM7S series) or 710 N (for TM6, TM12S, TM14S, and TM20S series) reaction force to the mounting surface and screws. In order to avoid decreased performance caused by robot slip or vibration, the recommended mounting surface should be a steel plate at least 20 mm thick, its flatness should be 0.1 mm or less, its surface roughness should be Rz25 or less. The recommended screw should be M10 x L30 mm, with a strength class of at least 8.8.
2. Do not immerse TM Robot in water. Installation in an environment with a relative humidity of higher than 85% can result in permanent damage to the system.
3. Do not side-mount the TM20S series. To ensure proper operation, install upright or inverted (with an angle of 0°–30° or 150°–180° relative to gravity).

**WARNING:**

Contact with liquids with chemical substances such as chemical solvents, lubricants, sanitizers, cleansers, etc. may cause damage to the joint covers or other components of the robot.

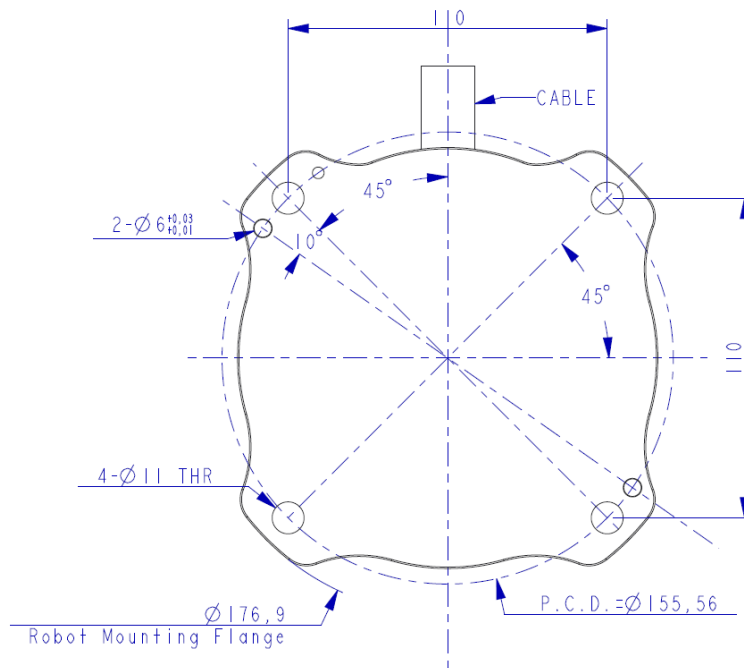


Figure 36: Bottom View of Robot Base (for TM5S / TM7S Series)

\*All measures are in mm.

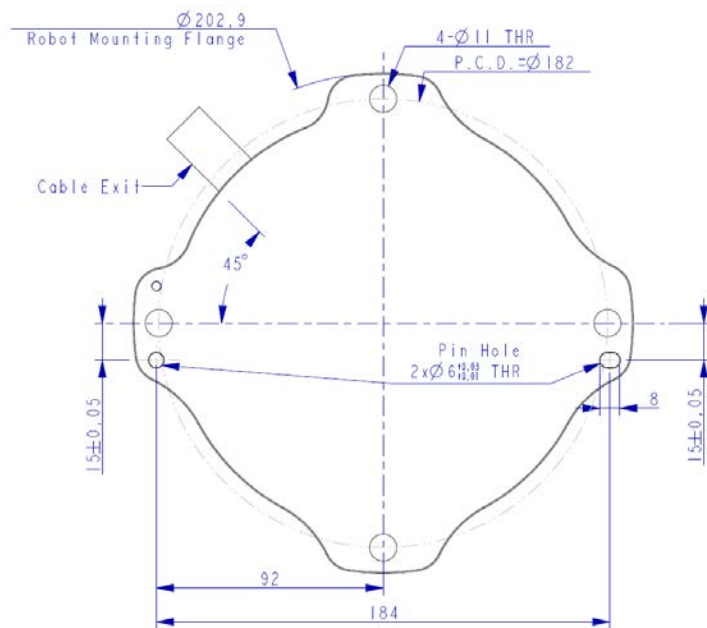


Figure 37: Bottom View of Robot Base (for TM6S / TM12S / TM14S / TM20S Series)

\*All measures are in mm.

Use the M4L5 pan head screw to secure the ground wire with the robot as shown below.



Figure 38: Grounding position for the robot

## 4.2.2 Robot End Module

### 4.2.2.1 End Module Components

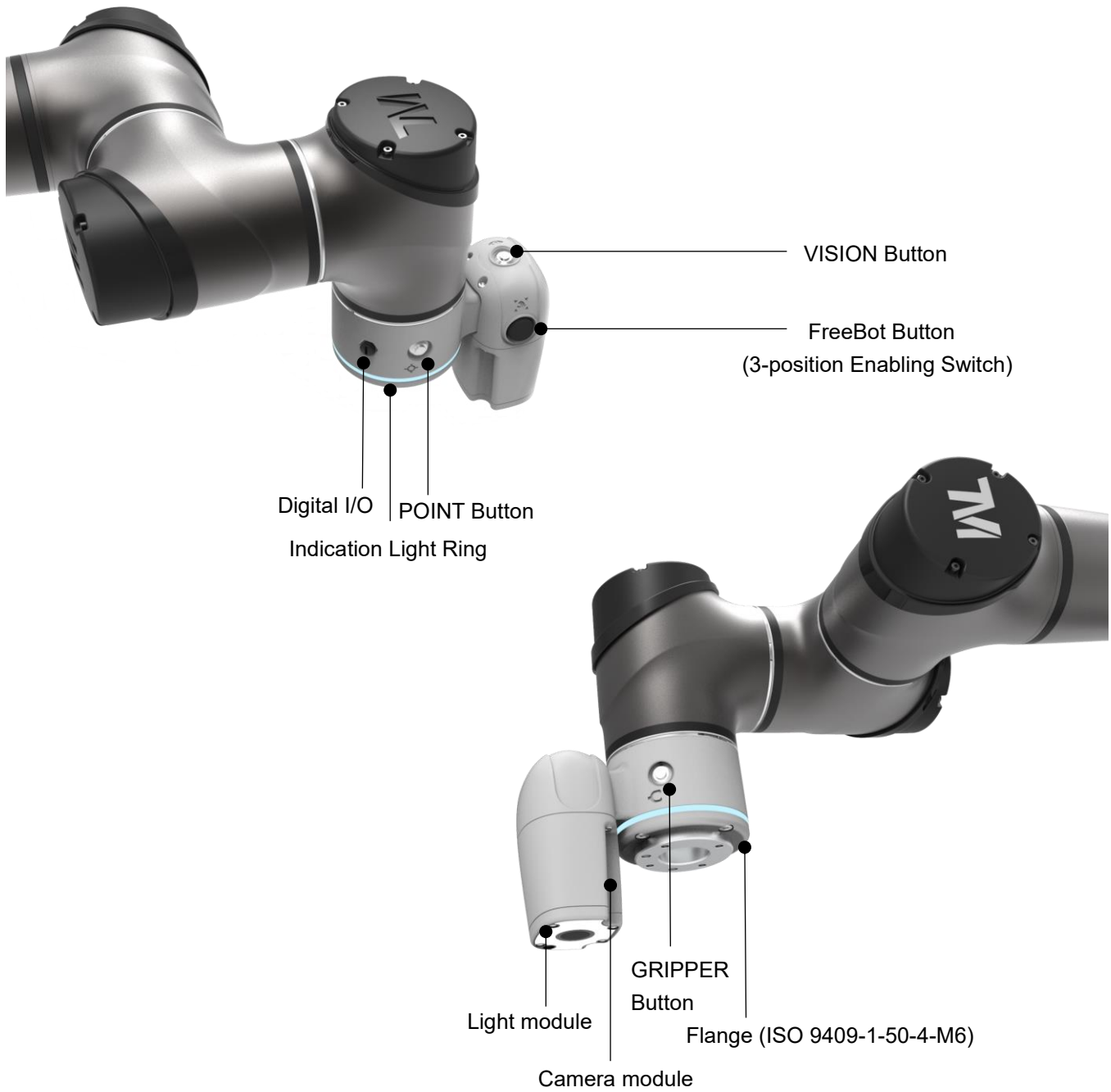


Figure 39: References of TM5S / TM7S / TM6S / TM12S / TM14S / TM20S Series End Module Components

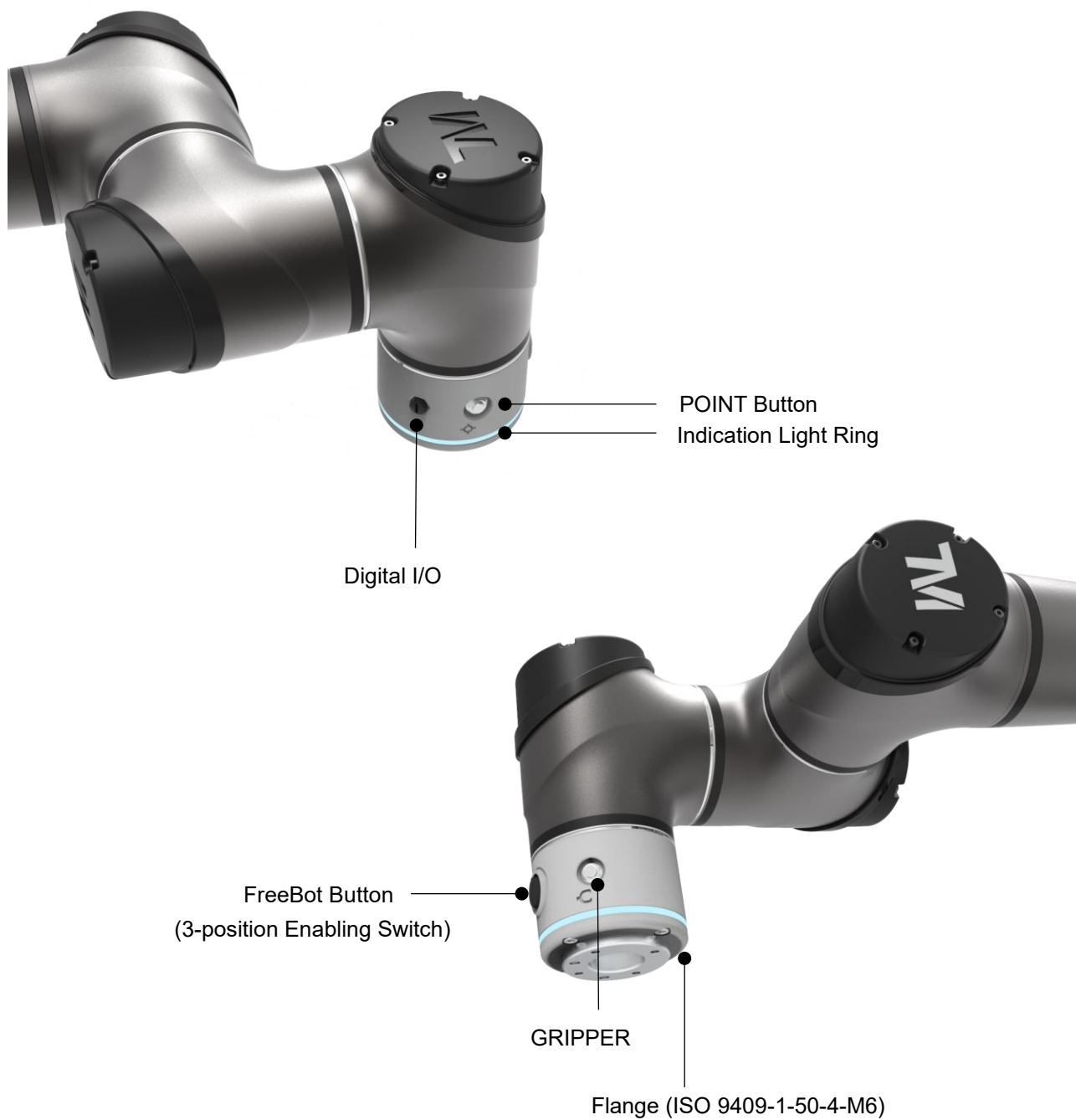


Figure 40: References of TM5S-X / TM7S-X / TM6S-X / TM12S-X / TM14S-X / TM20S-X Series End Module Components



**NOTE:**

There are two contacts in the Enabling Switch (FreeBot Button) that are designed to operate independently. Pressing the edge of the Enabling Switch causes one contact to engage earlier than the other contact, which results in a discrepancy in the timing of the dual-channel enable signal. A safety protection mechanism will be initiated after the discrepancy occurs. To reset the error, hold the Enabling Switch in the middle position for one second, then release it, and hold the Reset button for at least one second. The robot should release the brakes and resume normal operation.

#### 4.2.2.2 Flange Surface of the Robot End

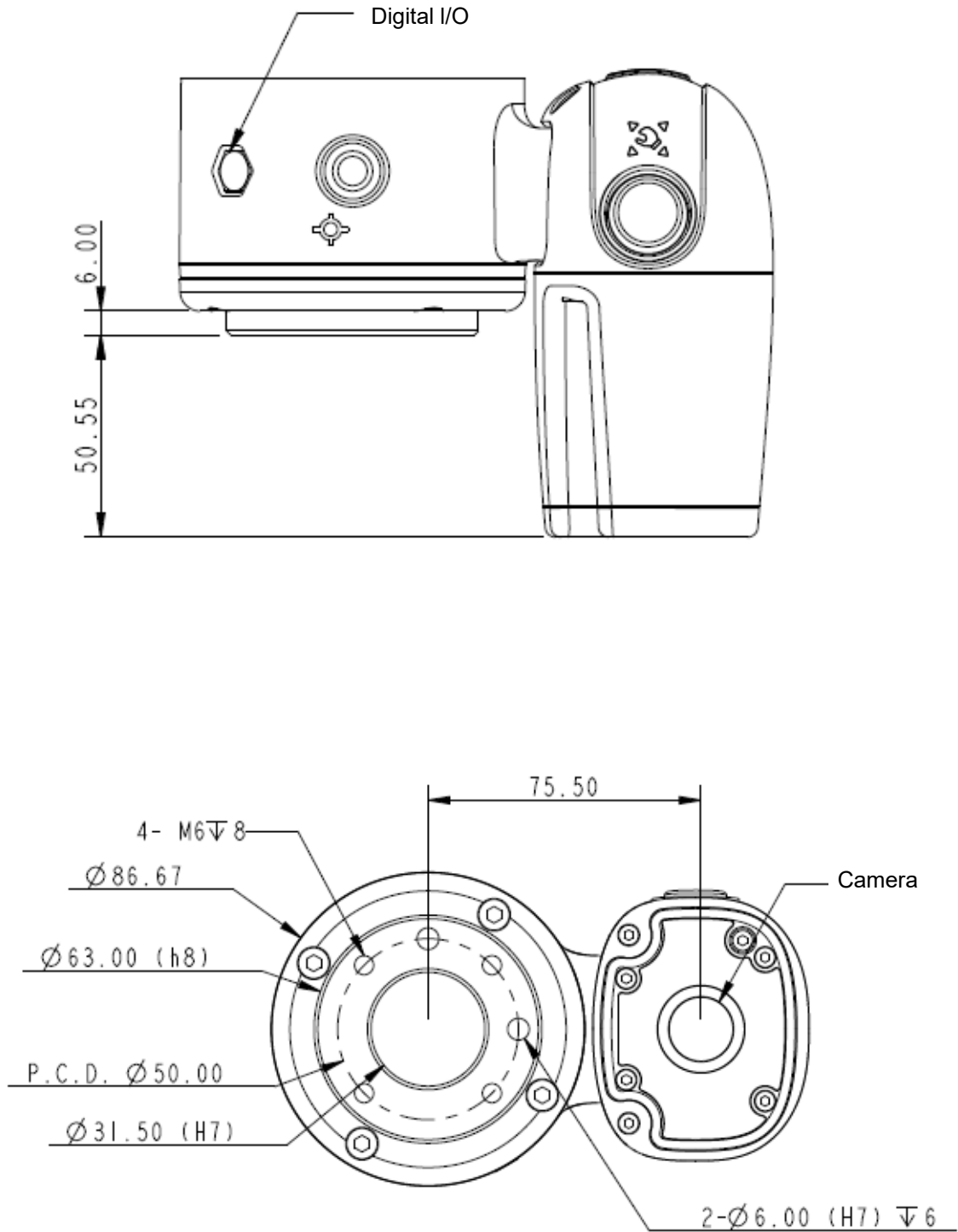


Figure 41: References of the Flange Surface of the Robot End

\*All measures are in mm.

#### 4.2.2.3 End Mounting Caution

The TM5S, TM6S, TM7S, TM12S, TM14S, and TM20S Series use four M6 threaded holes on the robot end of the flange and four M6 screws for mounting tools. The strength class of the M6 screw should be 8.8 or above, and the tightening torque of 9 Nm is recommended. If your application requires higher precision, you can use two positioning pins with a diameter of 6 mm for more secure mounting.



**DANGER:**

1. Tools must be properly tightened when using this product. Improper tightening may cause the tool or part to fall out, or even cause personal injury and death.
2. Follow the rule  $L \leq 8 + T$  to choose the screw to secure tools at the robot end of the flange, otherwise it may result in short circuits or irreparable damages at the bottom of the flange leading to the relevant parts replacement.

L	Length of the screw to secure tools. Unit: mm
8	Depth of the thread in the screw hole at the robot end of the flange. Unit: mm
T	Thickness of the object to be fixed. Unit: mm



**CAUTION:**

The application of mounting an actuator in the tool end with high vibration or impact may cause damage to the robot. Design the tool with proper anti-vibration/impact such as damping/cushion or shock absorber, or use low impact actuator such as pneumatic cylinder/system with shock absorb/buffer/cushion design to prevent this.

#### 4.2.2.4 End Indication Light Ring Table

The Indication Light Ring of the TM Robot has several colors which represent different modes and error status. Refer to the *Omron TM Collaborative Robot: Software Manual TMFlow, Version 2 (Cat. No. I689)* for the definition of the light colors.

### 4.2.3 Control Box

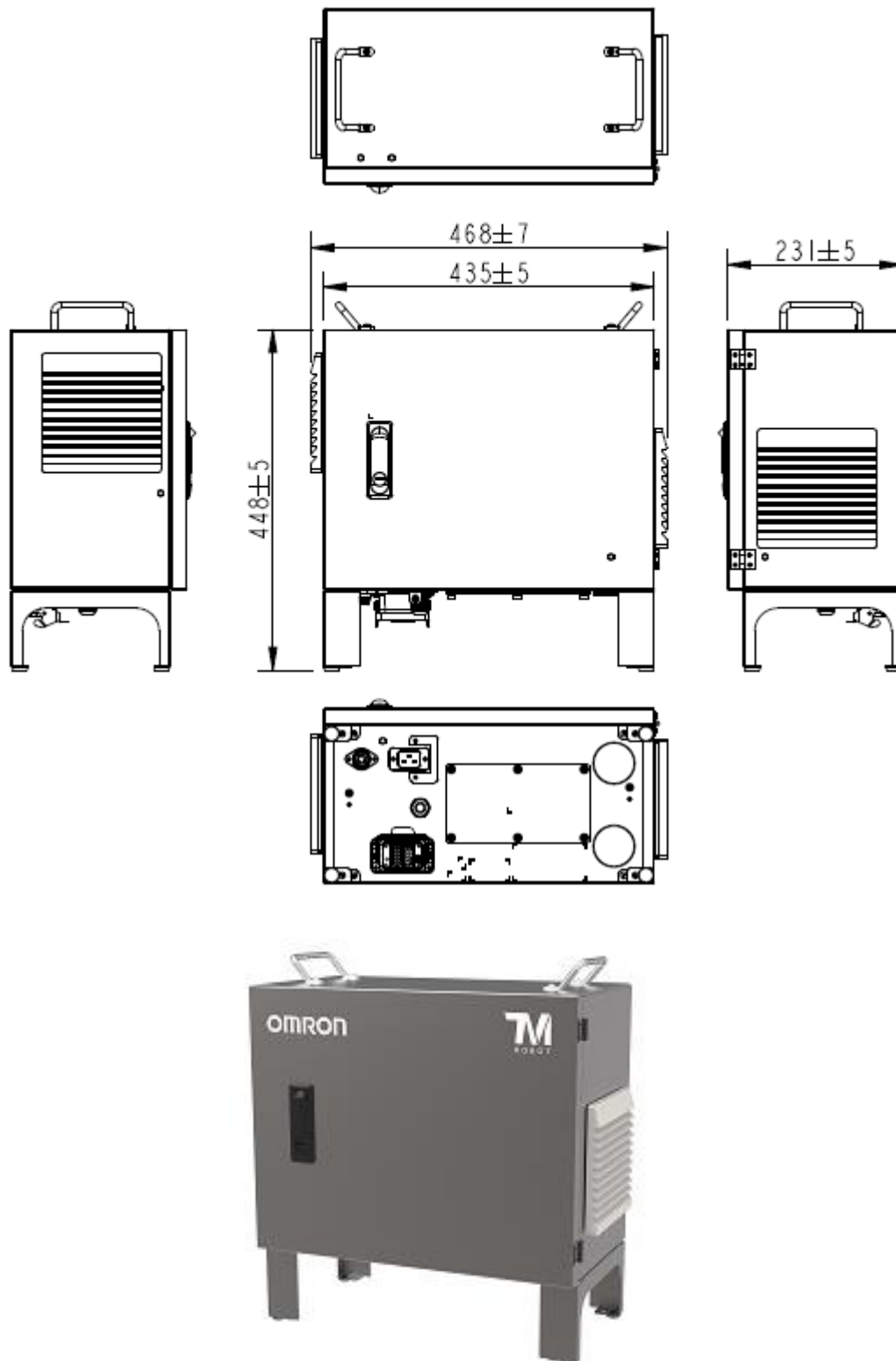


Figure 42: The Exterior and Diagram of the Control Box  
\*All measures are in mm.

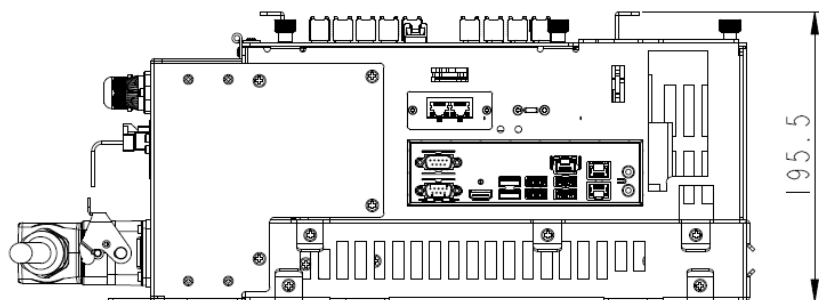
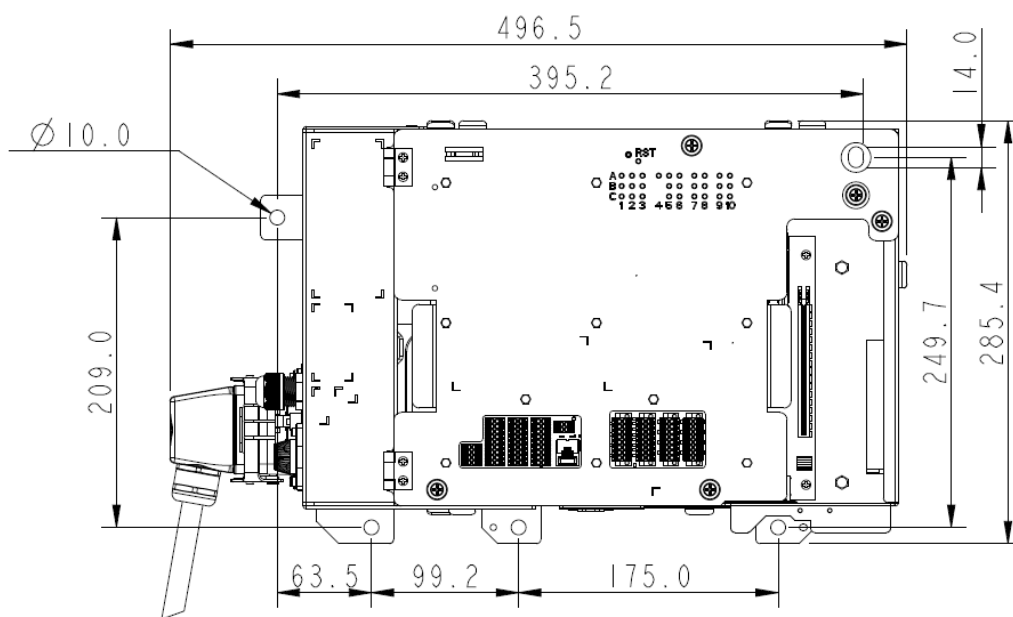


Figure 43: Dimensions of the DC Control Box

\*All measures are in mm.

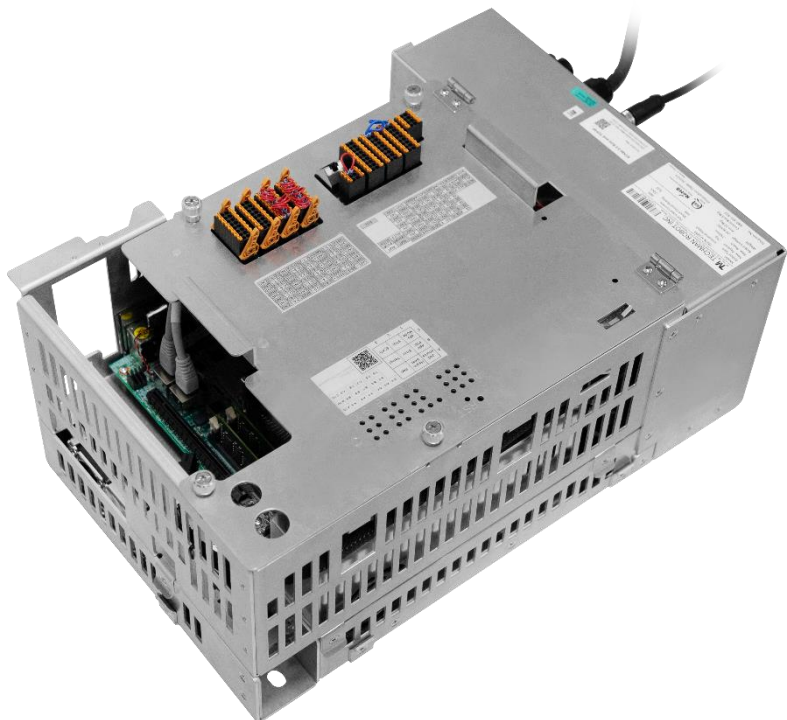
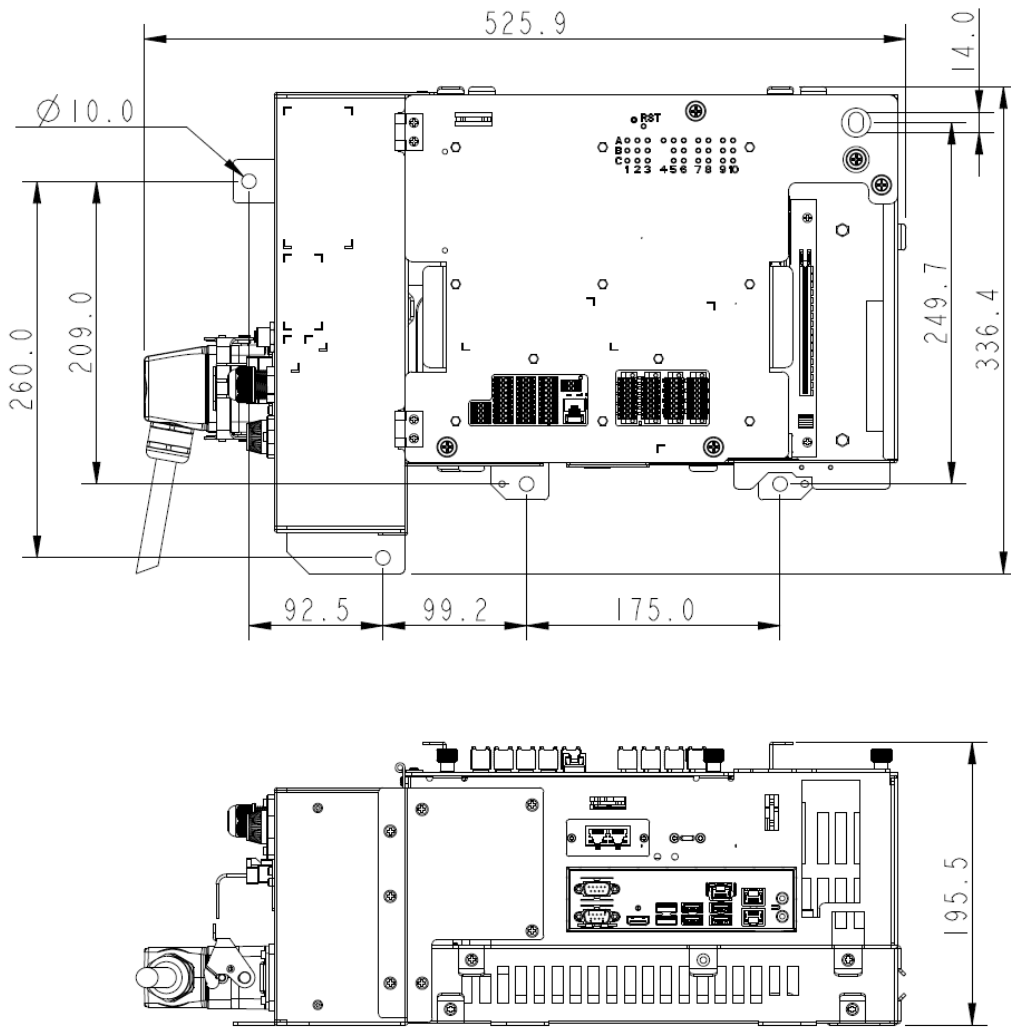


Figure 44: Dimensions of the DC SEMI Control Box  
 \*All measures are in mm.

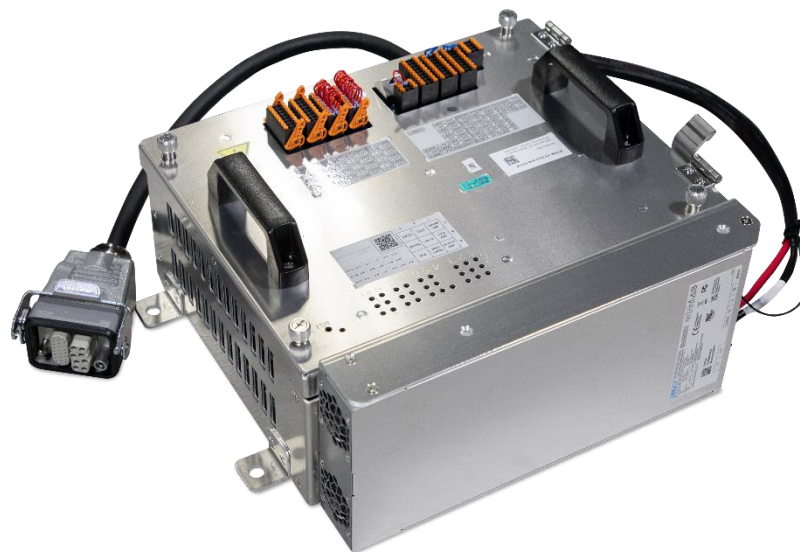
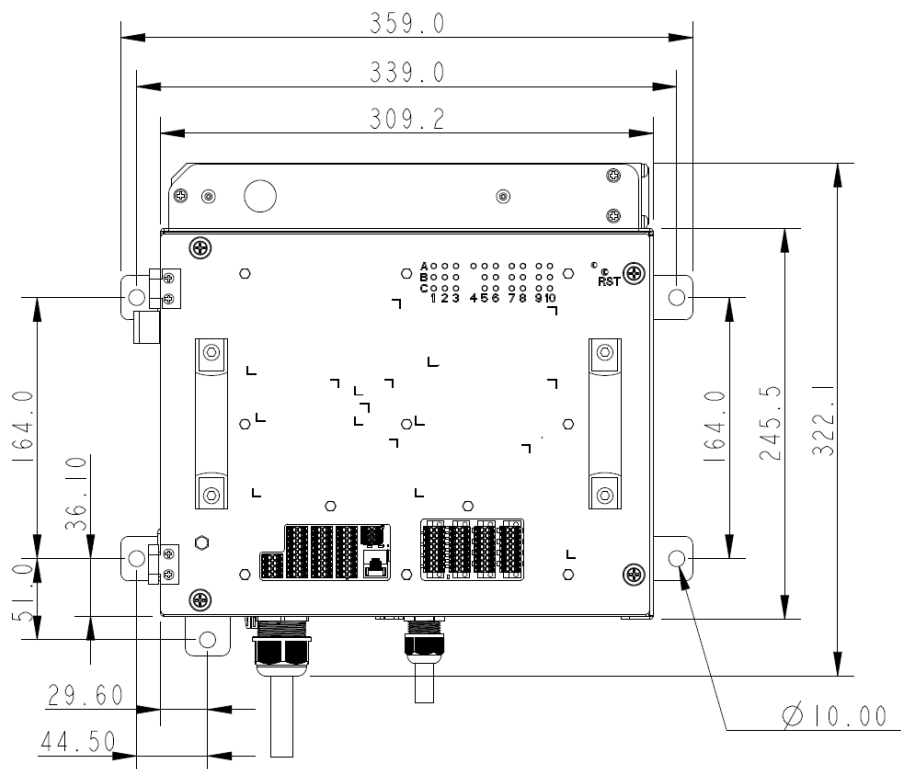


Figure 45: Dimensions of the Nano DC Control Box

\*All measures are in mm.

Use the M4L6 screw to secure the ground wire with the Control Box as shown below.



Figure 46: Grounding position for the Control Box

**CAUTION:**

- Before any cable is plugged into the Control Box, replace the waterproof rubber plugs at the base of the box with compatible cable glands.
- Recommended cable gland: BG-48 (manufactured by KSS)

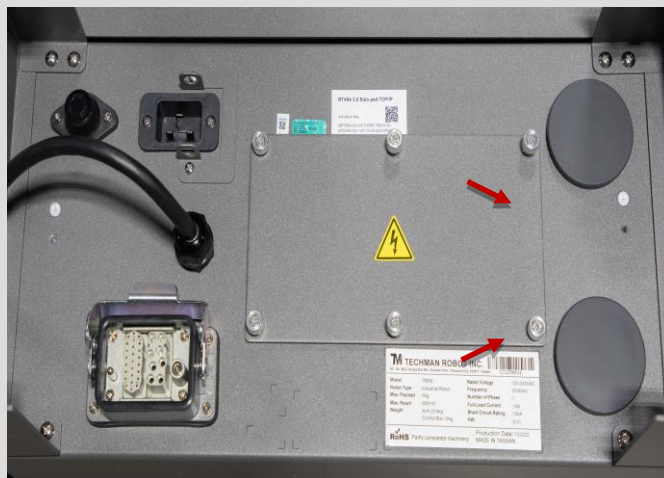
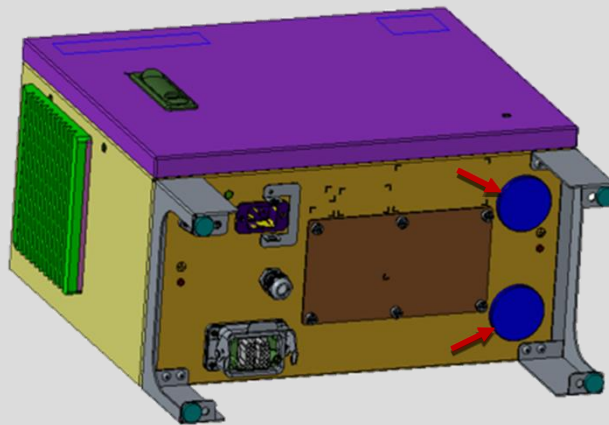


Figure 47: Waterproof Rubber Plugs of the Control Box

#### 4.2.3.1 Robot Stick

The Robot Stick has 1 Power Button (combined with an indicator), 1 Emergency Stop button, 1 Reset button, 1 Enabling Switch (combined with 1 mode indicator), 6 function buttons (Play, Pause, Stop, M/A, +, -), 3 light indicators and 1 set of speed indicators. Their functions are defined as follow:

<b>Dimensions</b>	130.00×163.72×105.00 mm
<b>Weight</b>	360g without cable 480g with 1-meter cable
<b>IP Classification</b>	IP54

Table 5: Specifications of the Robot Stick

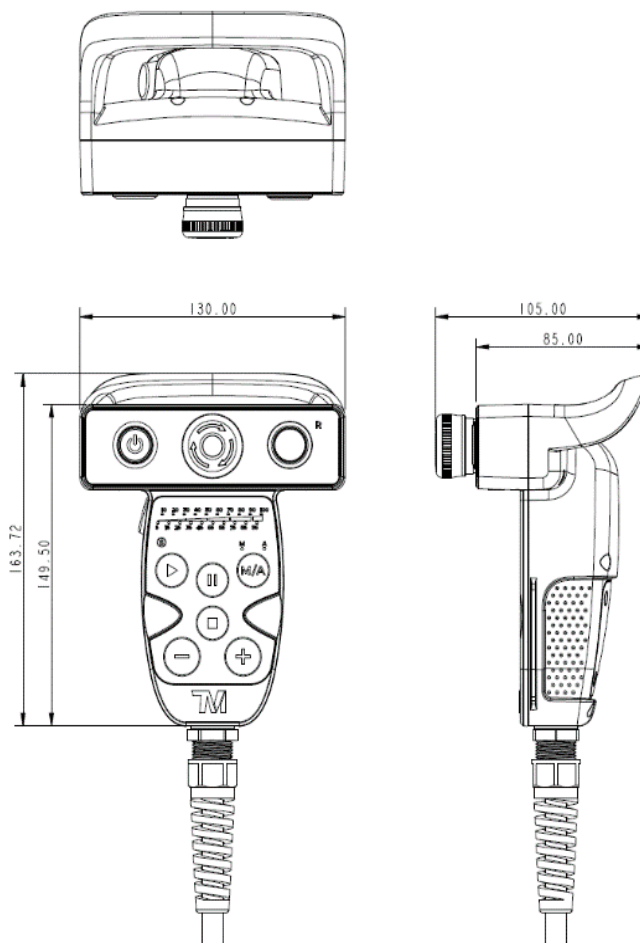


Figure 48: Dimensions of the Robot Stick



Figure 49: Robot Stick (front)



Figure 50: Robot Stick (back)

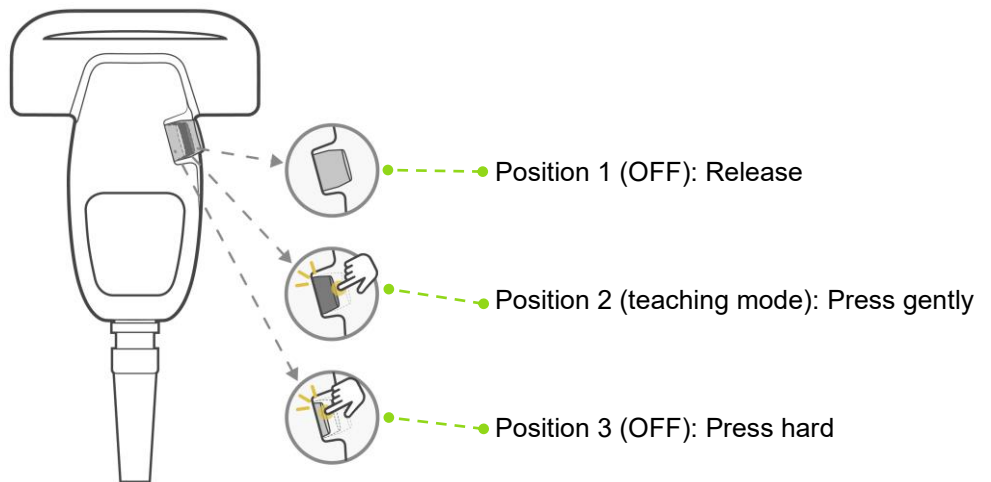


Figure 51: Operation of the Enabling Switch

**NOTE:**

- To ensure the operator's safety, the Enabling Switch on the Robot Stick can only be activated at Position 2, when the robot enters the teaching mode. If the switch is instead pressed at Position 1 or 3, the robot enters the non-teaching mode and does not move.
- There are two contacts in the Enabling Switch and the Reset Button that are designed to operate independently. Pressing the edge of the Enabling Switch turns on one contact earlier than the other contact, causing a discrepancy in the enable signals. A safety protection mechanism will be initiated after the discrepancy occurs. Users are required to resume following the instruction log from HMI.



**CAUTION:**

When operating the robot stick, do not use other objects than fingers to press the robot stick.



**CAUTION:**

There are notable differences in robot stopping behavior between pausing the robot with the Play/Pause Button and stopping the robot with the Stop Button. Please refer to the *Omron TM Collaborative Robot S Series: Safety Manual (Cat. No. I688)* for more information on the robot's ESTOP behavior.

- When the Play/Pause Button is used, the robot takes more time to decelerate to a complete stop, allowing for a more smooth transition from the moving state to the paused state.
- When the Stop Button is used, the robot must decelerate to a stop quickly, which can result in an abrupt stopping behavior. This could lead to high torque on the joints, especially with higher speed and payload.



Items	Basic Function
Power Button (with indicator)	Power initiation (single press)/ Shutdown (long press) OFF: Switched off Constant: Startup completed
Emergency Stop button	Default Emergency Stop button for the robot. Stop robot motion when emergency situation occurs. See <i>Omron TM Collaborative Robot S Series: Safety Manual (Cat. No. I688)</i> for details.
Reset Button	Default Reset button for the robot. Recover the robot from latching safety or error statuses. See <i>Omron TM Collaborative Robot S Series: Safety Manual (Cat. No. I688)</i> for details.
Speed Indicator	Display the current executing project override speed.
Enabling Switch	Default Enabling Switch for the robot. Manual control operations are permitted when continuously hold at the center position. See <i>Omron TM Collaborative Robot S Series: Safety Manual (Cat. No. I688)</i> for details.
Play Button	Play project (single press)
Pause Button	Pause project (single press)
Stop Button	Stop project (single press)
M/A Button	Default MODE switch function for the robot. See <i>Omron TM Collaborative Robot S Series: Safety Manual (Cat. No. I688)</i> for details.
+/- Button	Adjust project override speed (single press) during project execution. See <i>Omron TM Collaborative Robot: Software Manual TMFlow, Version 2 (Cat. No. I689)</i> for details.
Robot Stick Enable Indicator	This indicator shows the Enable/Disable of Robot Stick: Constant: Robot Stick enable Flashing: 6 function buttons of Robot Stick locked, See Advanced Function below OFF: Robot Stick disable See <i>Omron TM Collaborative Robot S Series: Safety Manual (Cat. No. I688)</i> for details.
MODE Indicator	One is MANUAL MODE; the other is AUTO MODE. They show the robot's current Operation Mode. Once boot up is complete, only one indicator will always be on.

Table 6: Robot Stick Basic Functions

Items	Advanced Function
Play Button	<ul style="list-style-type: none"> <li>- Activate visual calibration operation (single press)</li> <li>- Record the project's override speed during project execution under AUTO MODE (long press)</li> </ul>
Stop Button	Stop visual calibration operation (single press)
+/- Button	<ul style="list-style-type: none"> <li>- Hold to run to jog the robot at the HMI robot controller page (long press). See <i>Omron TM Collaborative Robot: Software Manual TMFlow, Version 2 (Cat. No. I689)</i> for details.</li> <li>- Lock/Unlock 6 function buttons of Robot Stick: press and hold the - button until the Robot Stick Enable Indicator flashes, then follow the sequence "-", "+, -, -, +" to lock/unlock the 6 function buttons of Robot Stick.</li> </ul>

Table 7: Robot Stick Advanced Functions

**CAUTION:**

Secure the Robot Stick on a hookable surface where screws are fastened. Do not place it without proper fixation. Arrange the Robot Stick and its signal cable properly to prevent damage from pulling or tugging.

**DANGER:**

1. The Control Box, cables, power signal cables, and Robot Stick cannot be used when any of them is in contact with liquids. This may result in personal injury or death.
2. The Control Box comes with the IP54 rating, but it is not recommended to use the box in dusty and humid environments. Pay extra attention to environments with conductive dust (such as metal particles).
3. The Control Box can be placed in the standing posture.

#### 4.2.3.2 TM Screen (Optional)

The Robot Stick can be assembled into the TM Screen to create the TM Teach Pendant. Due to this design, the 6 function buttons of the Robot Stick (Play, Pause, Stop, M/A, +, -) will be hidden by the TM Screen after the assembly, but the 6 buttons will be displayed on the UI.

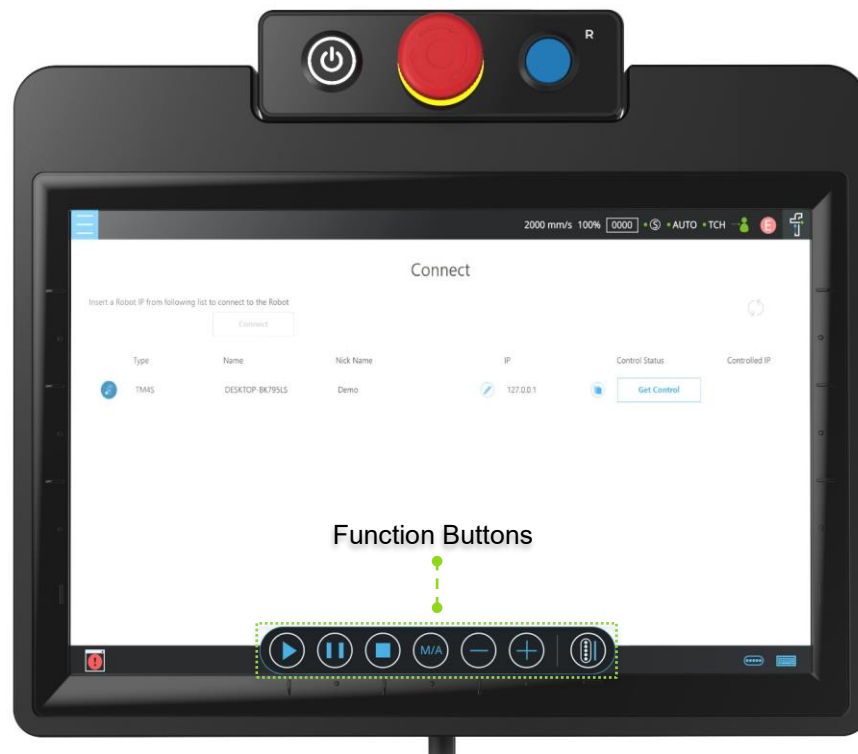


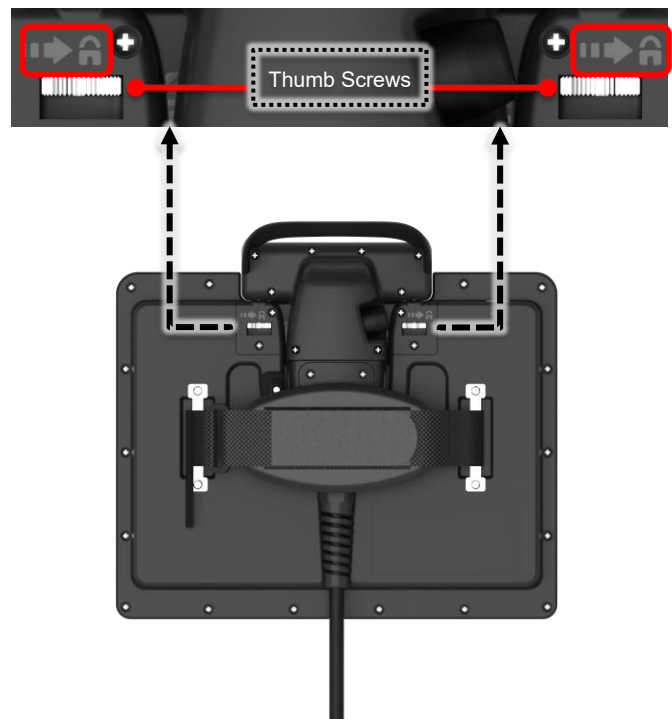
Figure 52: TM Teach Pendant (consisting of the TM Screen and Robot Stick)

The installation of the TM Teach Pendant is described as follows:

1. Plug the TM Screen onto the Robot Stick along its side tracks.



2. Rotate to tighten both thumb screws on the back of the TM Screen to make sure the module are firmly combined with the Robot Stick.



**DANGER:**

When using the TM Teach Pendant, it is forbidden to integrate the robot with Screen/Keyboard/Mouse. This may cause the robot under multi-control situation. The system integrator is responsible for ensuring that the robot is under only one control source.

## 4.2.4 Robot Light Module

### 4.2.4.1 Light Module Surface

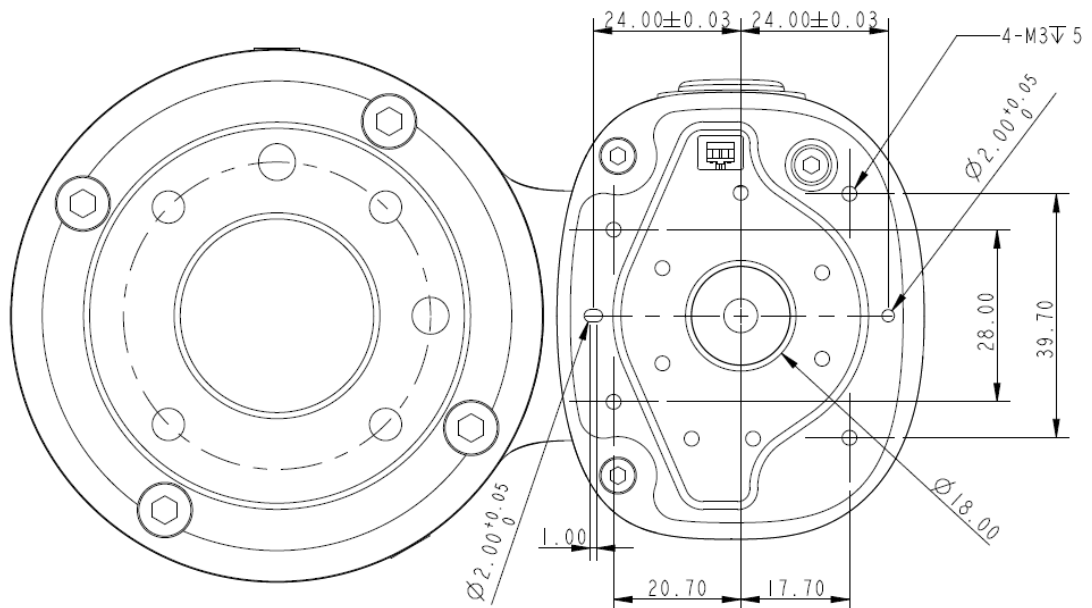


Figure 53: Light Module Surface

\*All measures are in mm.

### 4.2.4.2 Install Light Module

The light module uses 4 of M3 screws to fix, and the recommended tightening torque is 1 Nm. For higher accuracy on usages in demand, use both of the 2 mm diameter openings with the positioning pins to get the better steadiness. Users can replace the light module by applications in demand. The choice depends on the torque load of the light module, the available load of the robot, the possible influence the other light module made to the camera's field of view, and the electrical specifications.

1. The torque load of the light module (M): this torque load must be lower than 900 kgf-mm, which is the available strength of the camera module M3 screw can be loaded.

Calculation formula:  $M = (L+59.2)*W$

The weight of the light module	W	kgf
The center of gravity of the light module	L	mm

Table 8: Reference of the Symbol and Unit in Calculation the Torque Load of the Light Module

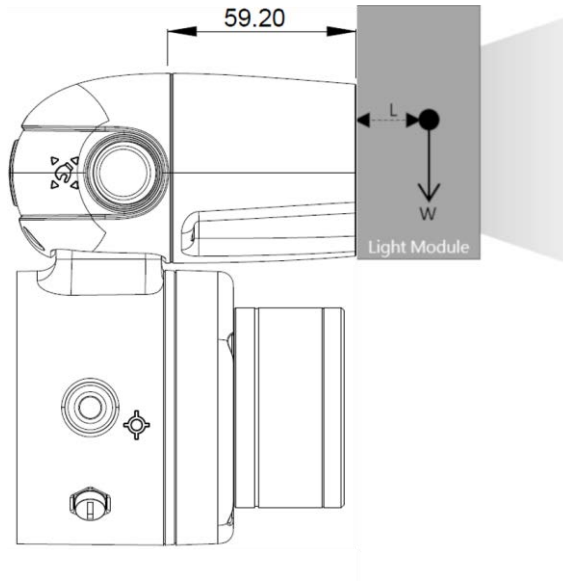


Figure 54: Calculation the Torque Load of the Light Module

\*All measures are in mm.

2. The maximum allowed payload of the robot: the weight of the light module must match the relative relationship between the maximum allowed payload and the center of gravity offset distance. If the robot end of the flange goes with additional applications, it is required to generate the equivalent center of gravity for its position and total load from the combination of the light module and the application tool as well as follow 4.2.1.4 Payload and Torque of this manual.
3. For the working distance and field of view of TM Robot's EIH camera, refer to 4.4.
4. Electrical Specification of the Light Module

<b>Voltage:</b>	24V	<b>Current (only for TM Robot's light module):</b>	< 100 mA
		<b>Current (for light modules from other manufacturers):</b>	< 900 mA

Table 9: Electrical Specification of the Light Module

**Fill light cable:**

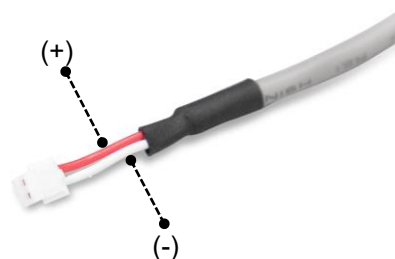


Figure 55: Electrical Polarity of Fill Light Cable

**Connector:** 2P/1.5 mm pin pitch. Refer to JST model ZHR-4 series.

**Dimming mode:** PWM control

**NOTE:**

The robot comes with the IP65 rating, but the Corporation does not guarantee this rating if users replace with the other light modules.

**DANGER:**

Be aware that the tool must be correctly and firmly secured to use with this product; otherwise, personal injuries or death may occur should the tool or the workpiece fall.

#### 4.3 Operating Position of TM Robot with AGV/AIV

When TM Robot is placed on an AGV/AIV in operation, the TM Robot should be paused and should not exceed the footprint of the AGV/AIV.

AGV/AIV Footprint



Figure 56: Top View of TM Robot Mounted on the AGV/AIV

#### 4.4 Working distance and field of view of TM Robot's EIH camera

The field of view of TM Robot's EIH camera varies linearly in accordance with the working distance. The minimum working distance is about 100 mm and the maximum working distance is about 300 mm. The zero working distance point is approximately 44.76 mm in front of the flange surface and right behind the center of the protection lens.

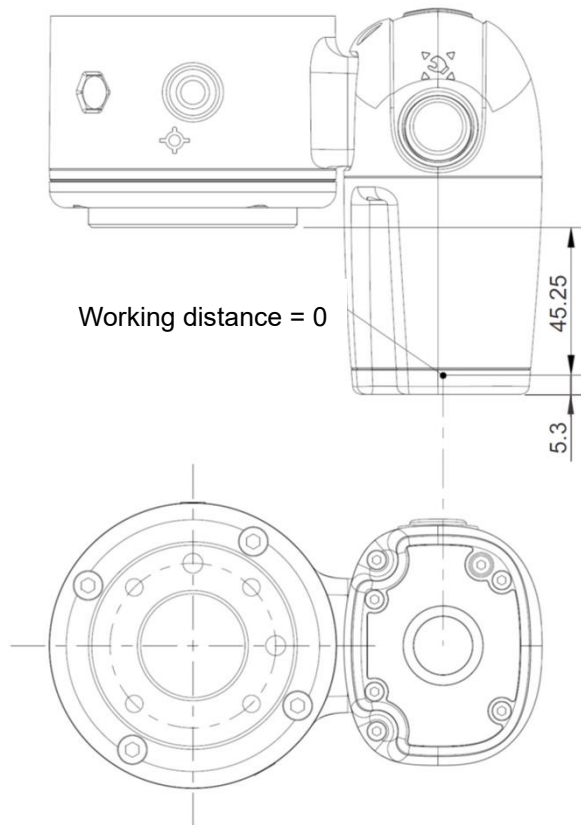


Figure 57: Working Distance and Field of View of TM Robot's EIH camera

\*All measures are in mm.

The relation between the working distance and the field of view is listed below.

<b>Working distance (mm)</b>	300	100
<b>Field of view (mm)</b>		
<b>Width</b>	281.6	96.9
<b>Height</b>	211.2	72.7

Table 10: The Relation between the Working Distance and the Field of View

## 5. Electrical Interface

### 5.1 Overview

This chapter introduces all electrical interfaces of the robot arm and Control Box.

### 5.2 Electrical Warnings and Cautions

The application design and installation of the robot should comply with the following warnings.



#### DANGER:

1. Ensure all pieces of the equipment are kept dry. If water enters the equipment, disconnect the power and contact your supplier.
2. Only use the original cables included with the robot. If you need longer cables, contact your supplier.
3. Ensure that the robot is properly grounded. If the grounding is not correct, it may cause a fire or electric shock.



#### WARNING:

The I/O cables used for the link between the Control Box and other pieces of equipment should not be longer than 30 meters, unless testing shows that longer cables are feasible.

### 5.3 Control Box

#### Control Box I/O configuration

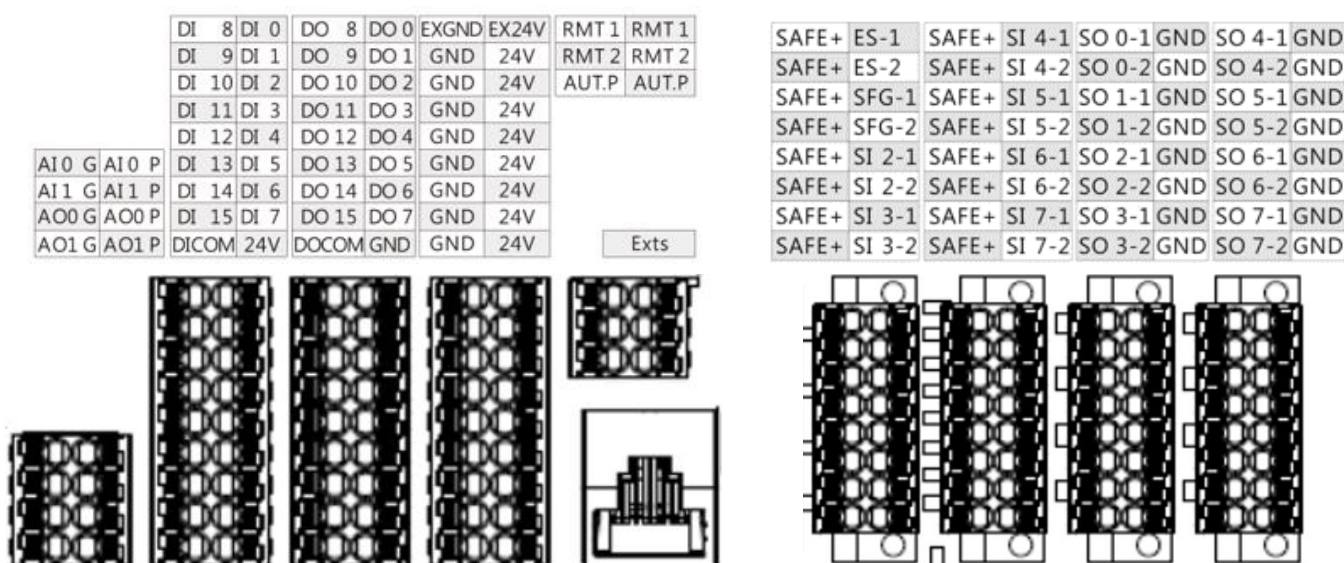


Figure 58: Control Box I/O Configuration

### 5.3.1 Safety Connector

Safety I/O comes with dual redundant channel connector and has to keep both channel input/output the same value simultaneously. Single fault on either one of the single channels will not result in failure of safety functions.

#### 5.3.1.1 Safety Input Connector

1. ES-1/ ES-2 are N.C. contact (Normally closed). When this Safety Input Port is OPEN, the robot initiates a Category 1 Stop.
2. SFG-1/ SFG-2 are a N.C. contact (Normally closed). When this Safety Input Port is OPEN, the robot initiates a Category 2 Stop.
3. SI 2-1/ SI 2-2 to SI 7-1/ SI 7-2 are user defined Safety Input Port. Safety functions can be assigned to these ports.

For details about the safety functions, please refer to the *Omron TM Collaborative Robot S Series: Safety Manual (Cat. No. I688)*.

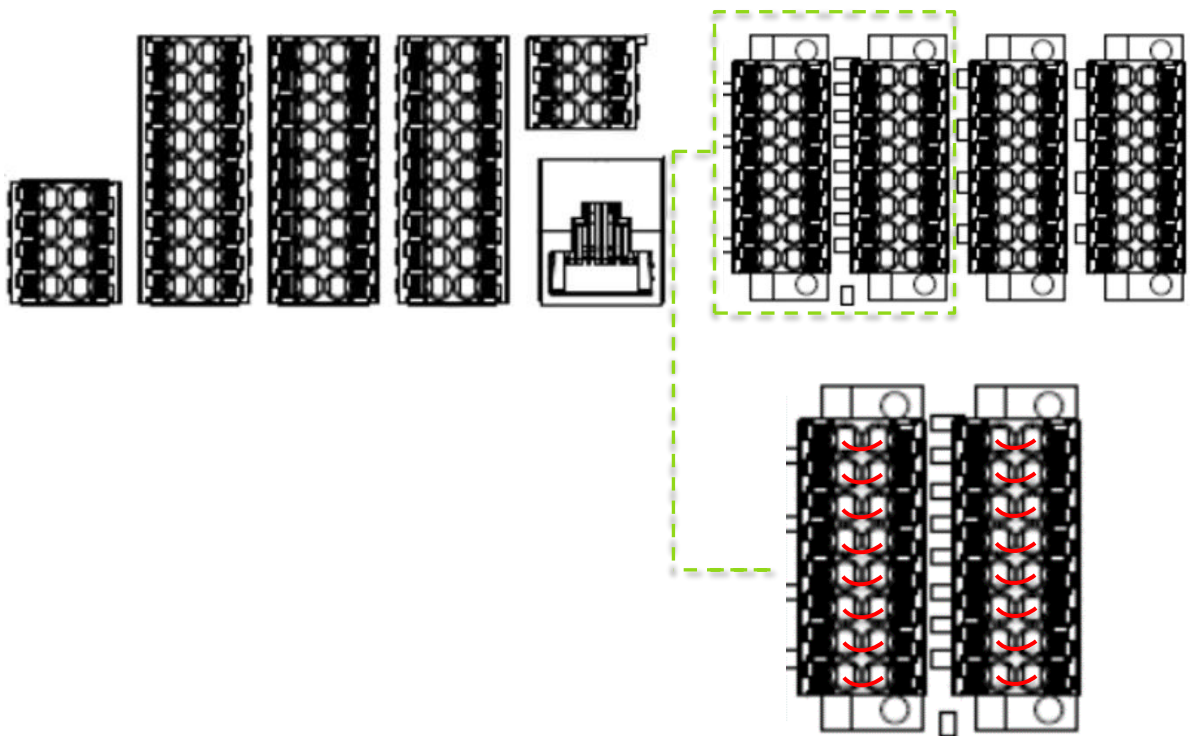


Figure 59: Safety Input Connector

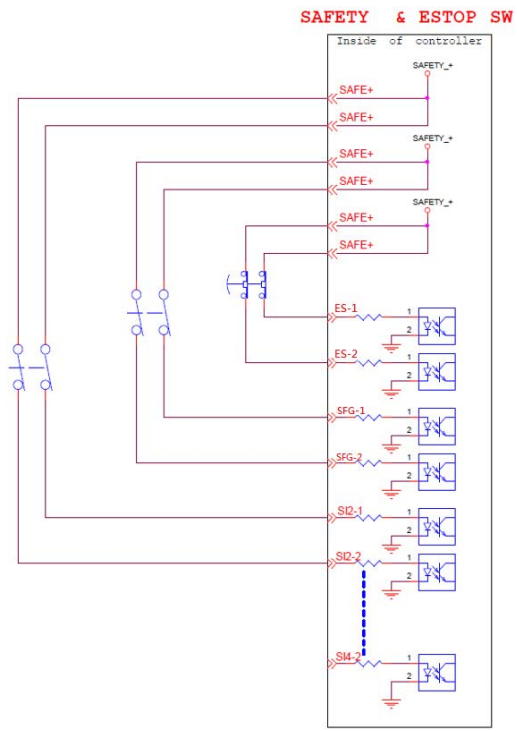


Figure 60: The Wiring Diagram Example of Switch Type Safety Device.

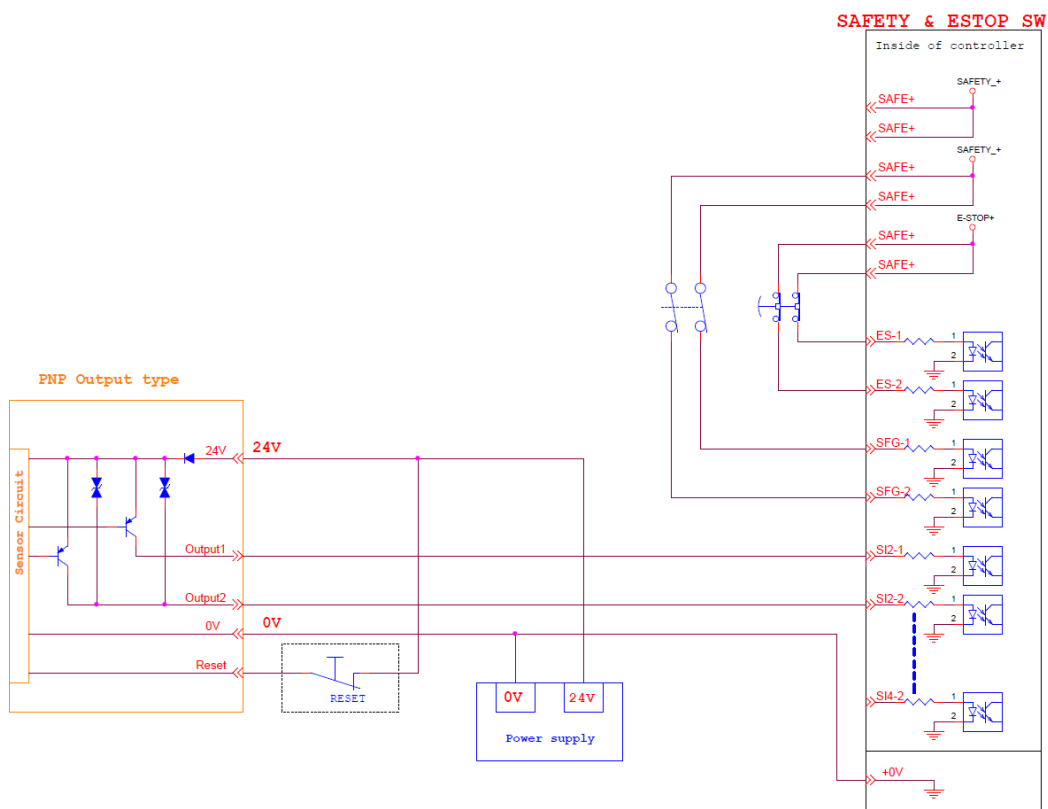


Figure 61: The Wiring Diagram Example of PNP Output Type Safety Device (1/2)

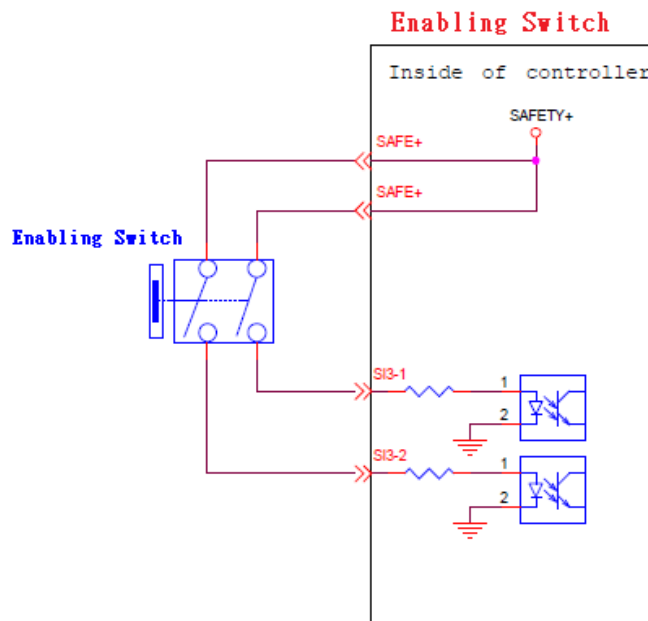


Figure 62: The Wiring Diagram Example of PNP Output Type Safety Device (2/2)

### 5.3.1.2 Safety Output Connector

1. SO 0-1/ SO 0-2 to SO 7-1/ SO 7-2 are user defined Safety Output Port. Safety functions can be assigned to these ports.

For details about the safety functions, please refer to the *Omron TM Collaborative Robot S Series: Safety Manual (Cat. No. I688)*.

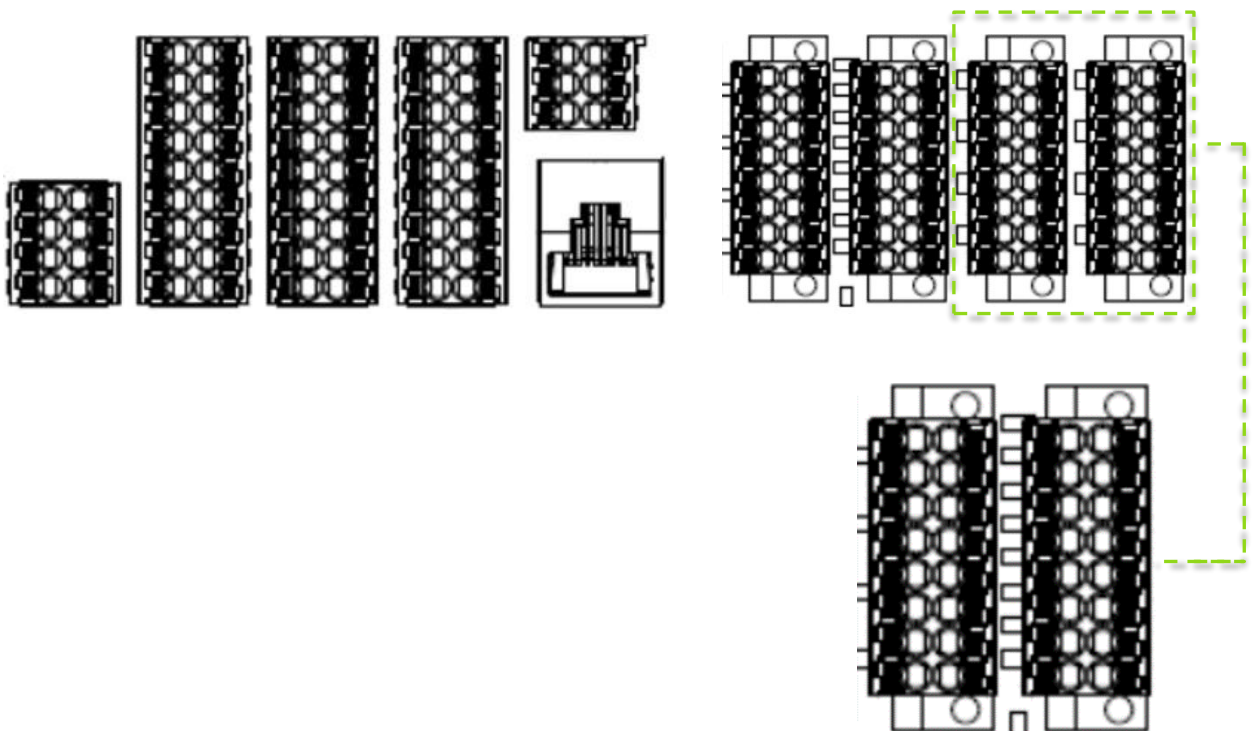


Figure 63: Safety Output Connector

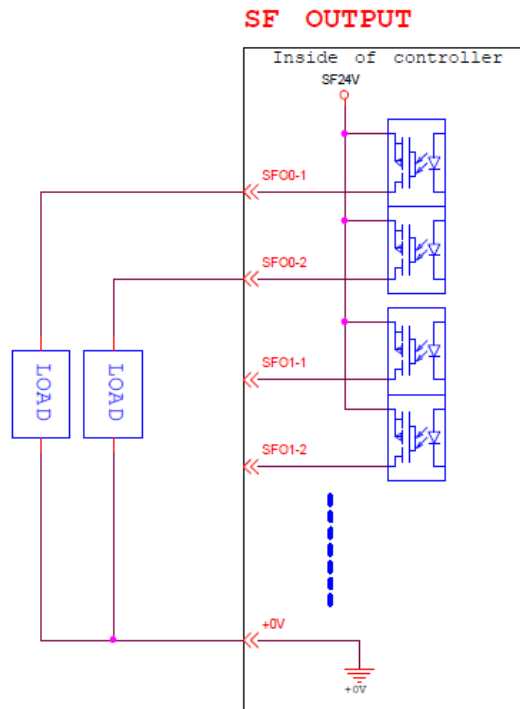


Figure 64: Safety Output Connector Wiring Diagram



**DANGER:**

1. Do not connect the safety signals to a non-safety device without the fulfilled safety level. Failure to do so may result in injury or death due to a malfunction of the safety stop.
2. All safety I/Os come with dual redundant channel connectors. Maintain both redundant channels while they are paired and connected, so that any single fault on either channel will not result in failure of safety functions.
3. Before putting the robot to use, be sure to check the safety functions and check the safety functions on a regular basis.

5.3.2 Power Connector

1. During boot, the Control Box will check for an external 24V input. If none is found, then it will switch to the internal 24V supply.
2. The Control Box itself offers a 24V/2A output. If the 24V load exceeds 2A, it enters Safe Mode and disables the 24V output.
3. EX24V provides an external 24V input port. If the load exceeds 2A an external power supply can be used instead. The load on EX24V must not exceed 3.5A.

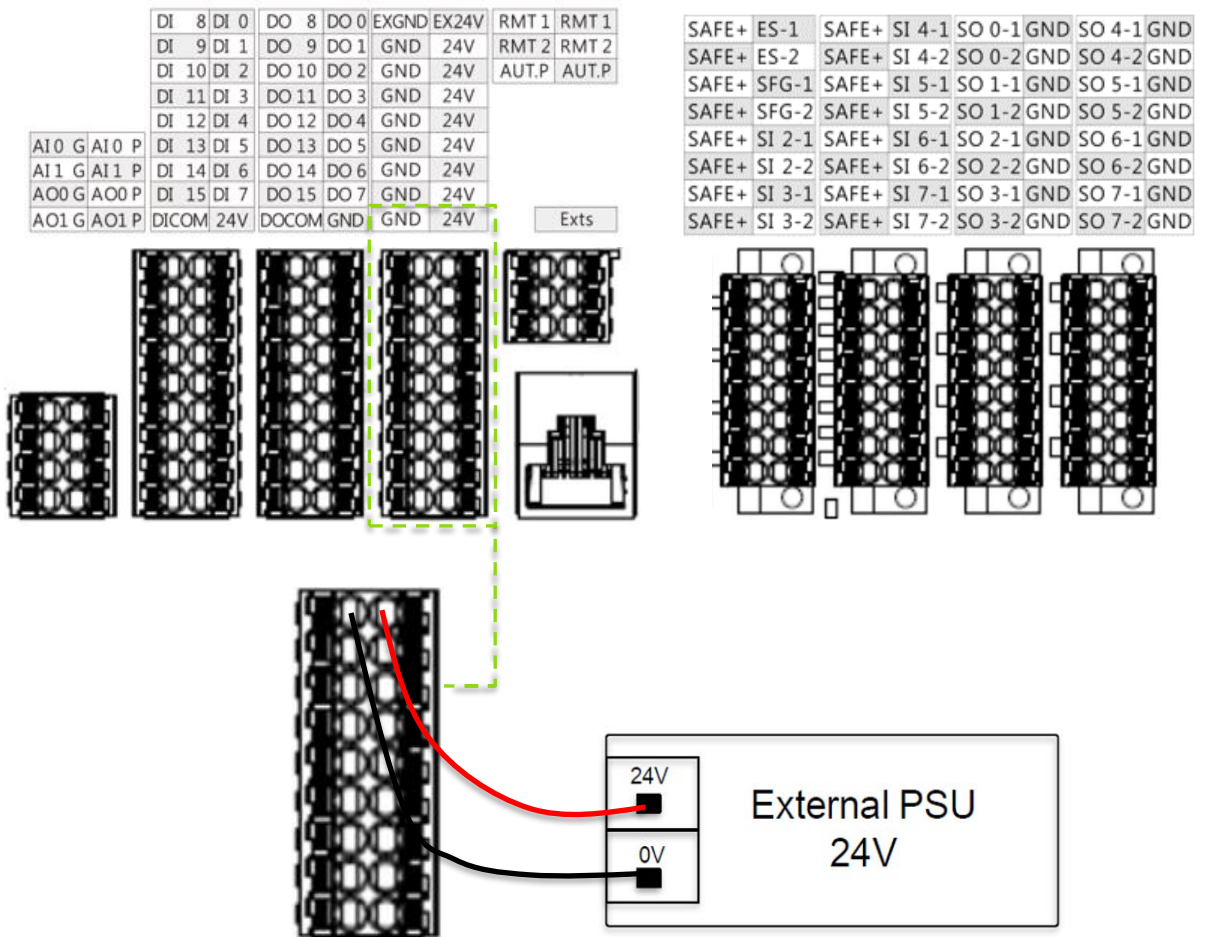


Figure 65: Power Connector

### 5.3.3 Digital In/Out

Digital input/output each has 16 channels, and its application is connected to the following sections.

#### 5.3.3.1 Digital Input

Inputs can be set to either sink input or source input by selection.

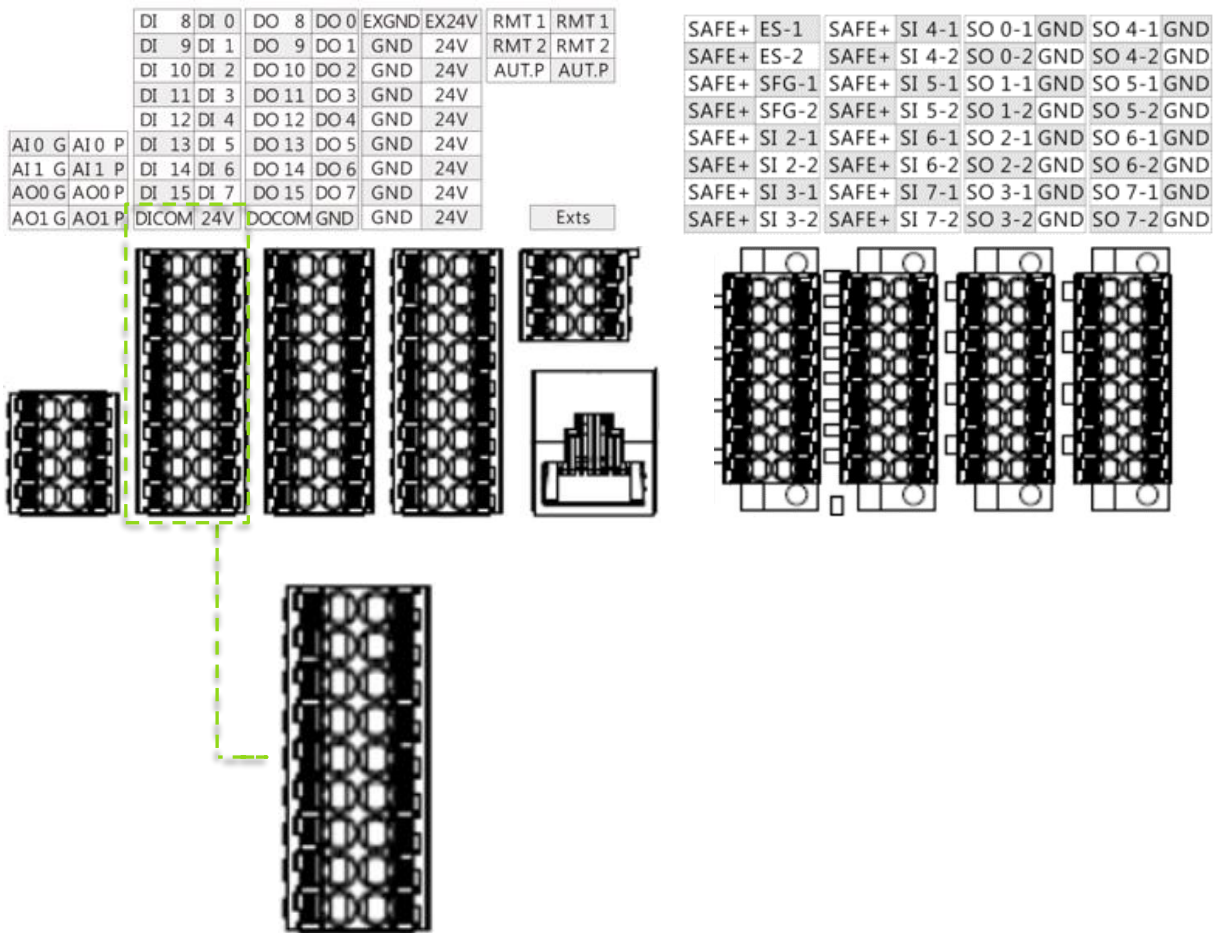


Figure 66: Digital Input

- Set to sink input type

When a device such as a transistor output sensor is connected, NPN open collector transistor output can be used.

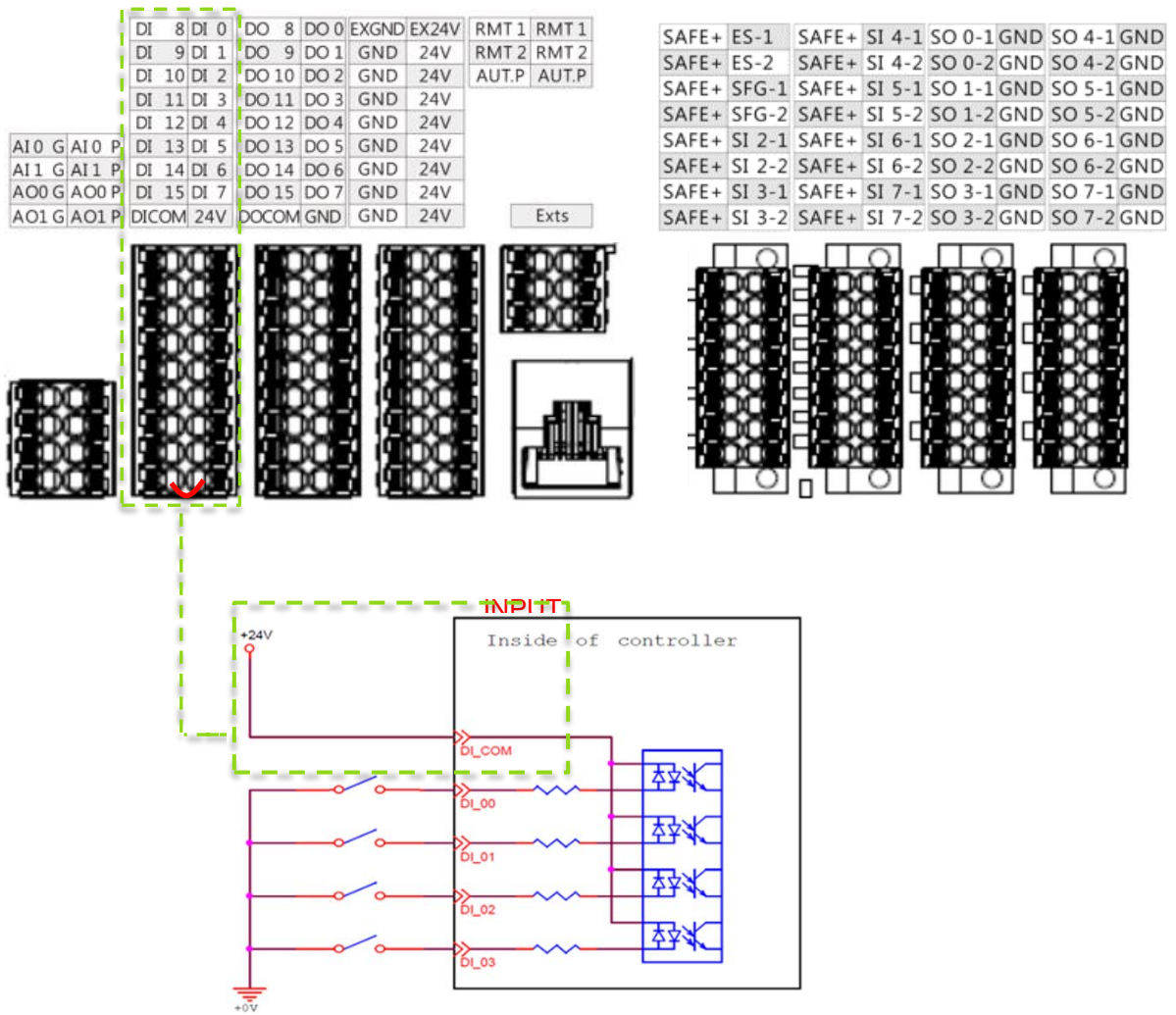


Figure 67: Set to Sink Input Type

- Set to Source input type

When a device such as a transistor output sensor is connected, PNP open collector transistor output can be used.

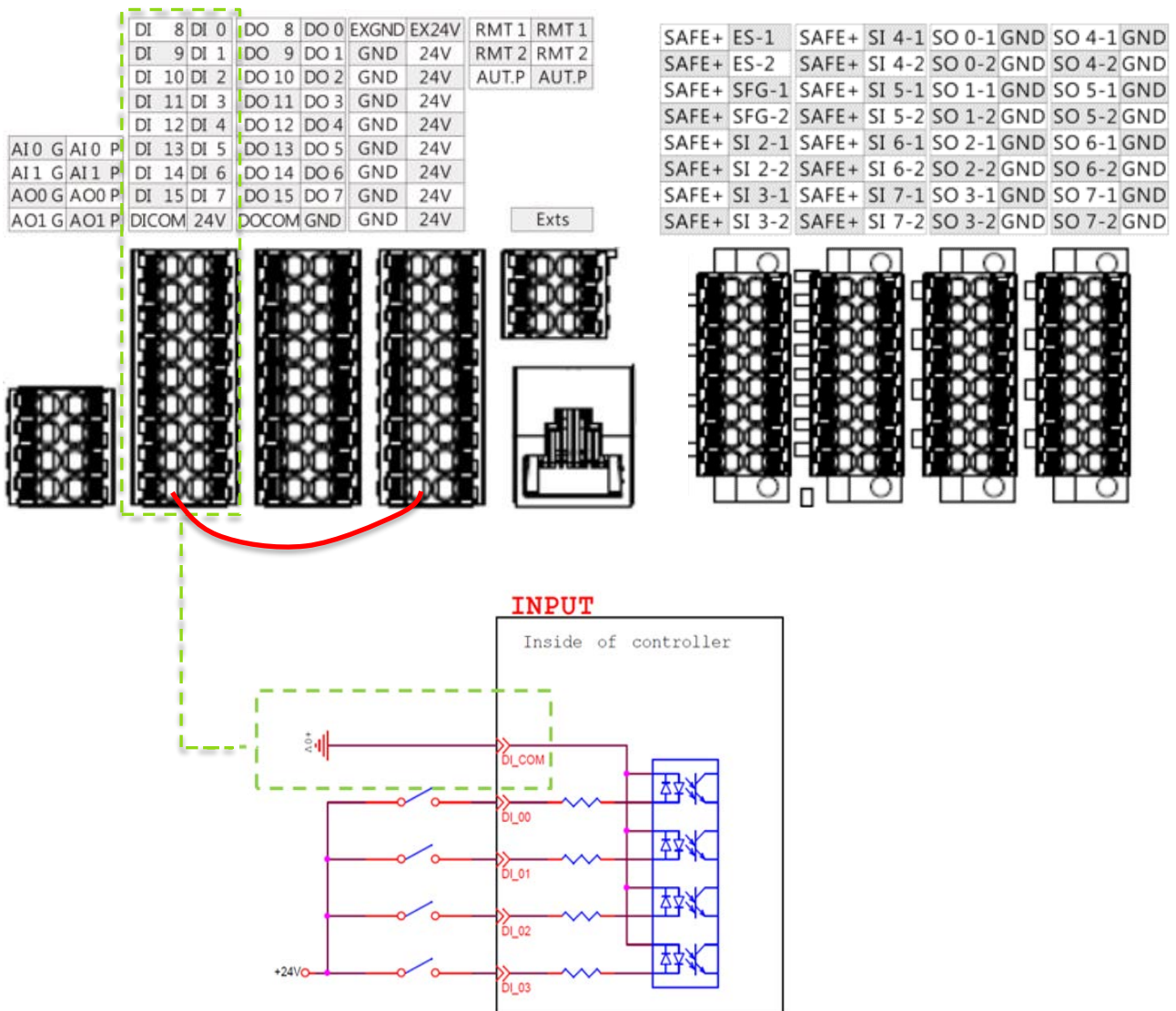


Figure 68: Set to Source Input Type

### 5.3.3.2 Digital Output

Outputs can be set to either sink output or source output by selection.

The maximum drive current is 300mA per channel. If the voltage generated by a load of over 300 mA or through counter-electromotive force from an external device exceeds what the Control Box can accommodate and damages the digital output devices, a relay should be used to provide driving force or an isolation mechanism be implemented.

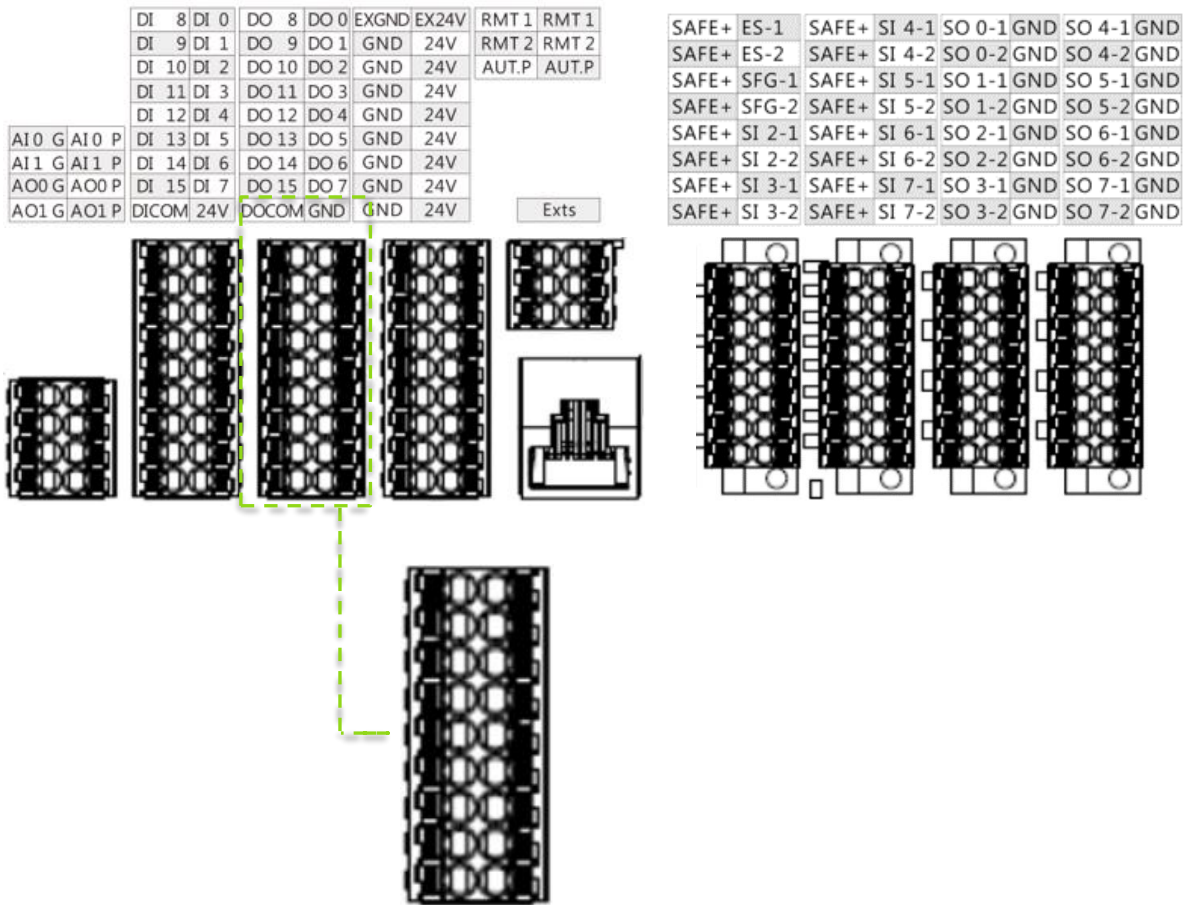


Figure 69: Digital Output

- Set to sink output type

Connect DO\_COM terminal to the minus side of the power supply.

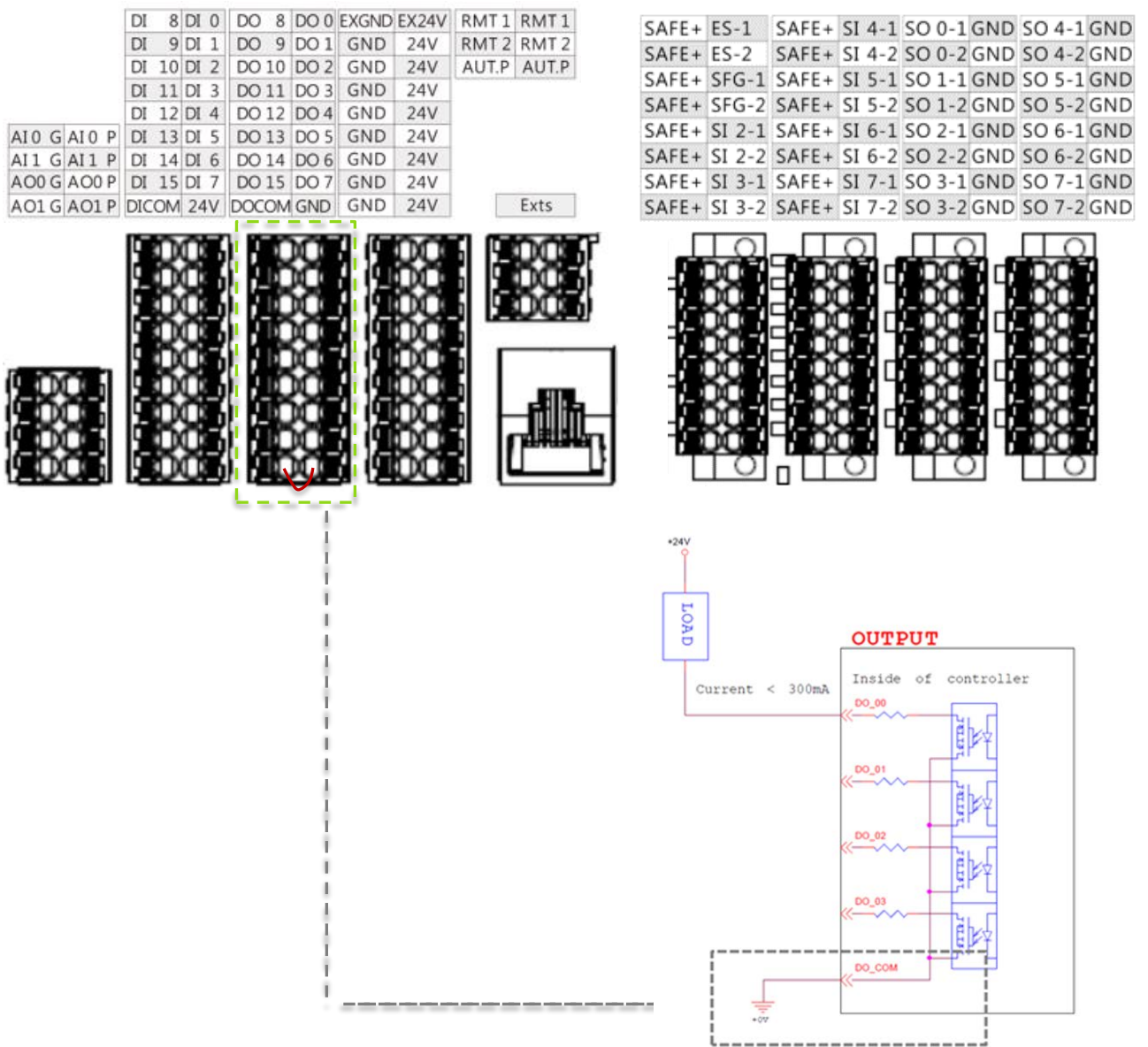


Figure 70: Set to Sink Output Type

- Set to source output type

Connect DO\_COM terminal to the plus side of the power supply.

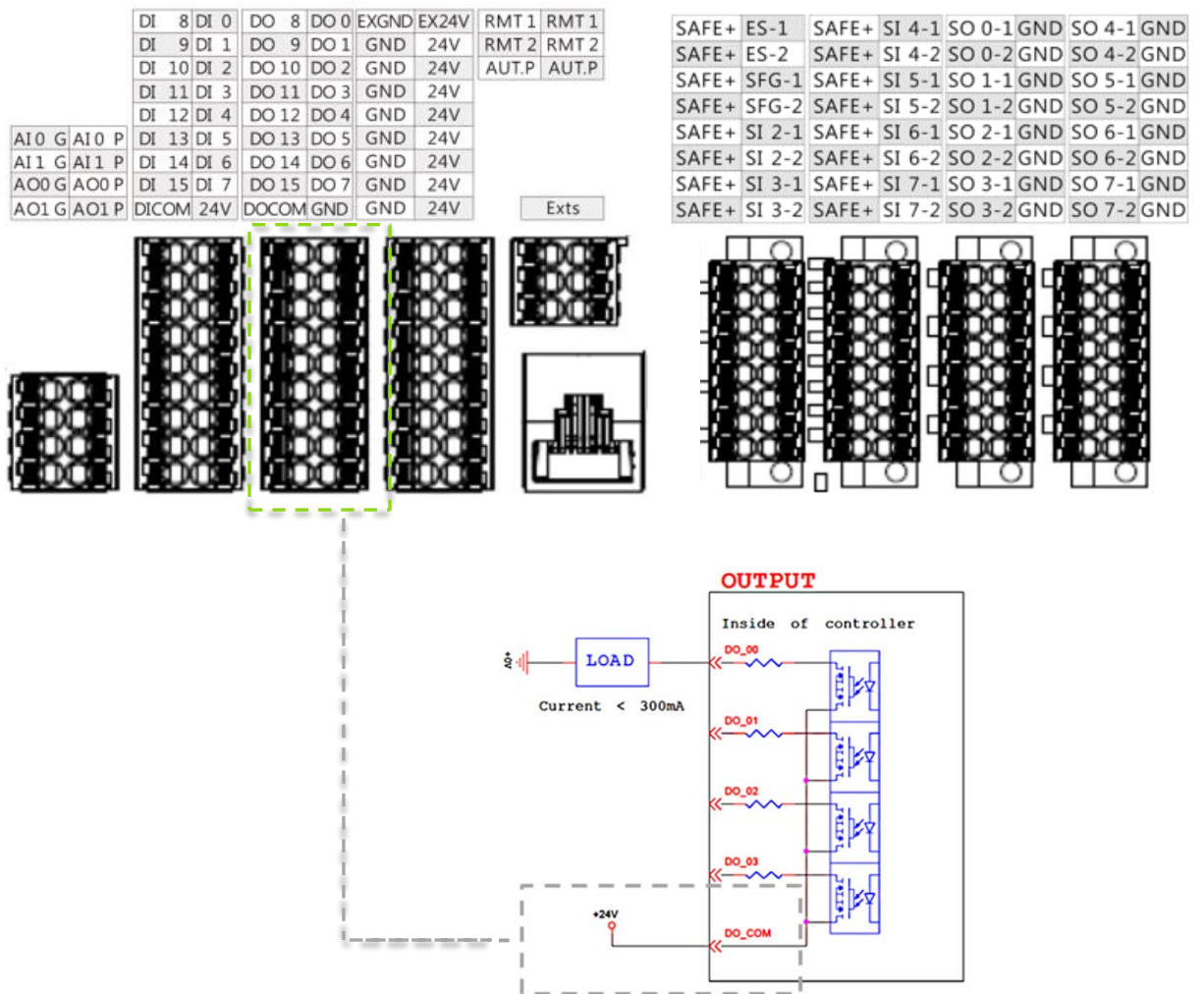


Figure 71: Set to Source Output Type

### 5.3.4 Analog In/Out

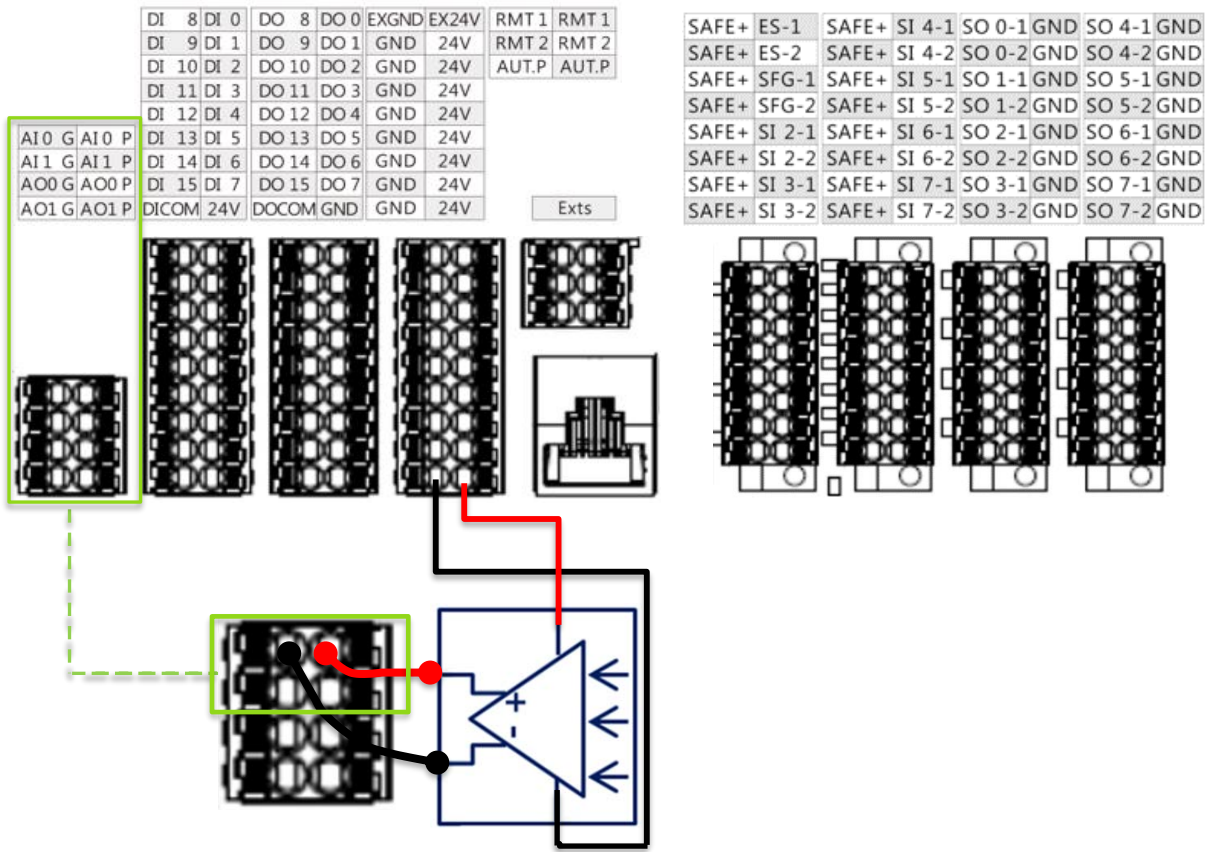


Figure 72: Analog In

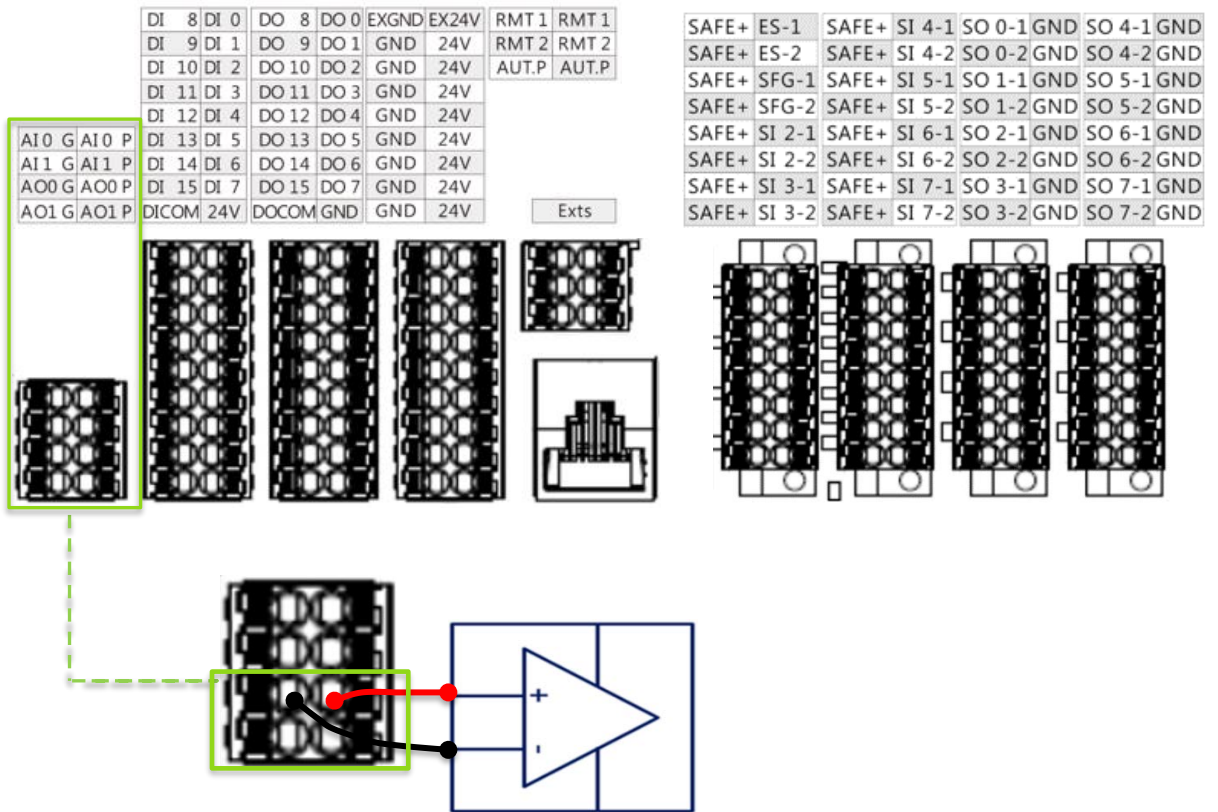


Figure 73: Analog Out

	Range	Resolution	Accuracy	Conversion Time	Max. Current	Min. Resistance	Absolute Maximum Rating
Analog In	+10.00V to -10.00V	11bit	≤ 0.2%	1 ms	X		+11V to -11V
Analog Out	+10.00V to -10.00V	11bit	± 0.07%	1 ms	10 mA	1000 Ω	X

Table 11: Analog In & Analog Out

### 5.3.5 System Remote Power ON/OFF

The function of Remote ON/OFF shares the same functionality of the Robot Stick Power Button. To power on the system, hold the Remote ON/OFF function for at least 1 sec. To shut down the system, hold the Remote ON/OFF function for at least 5 sec.

The respective remote ON/OFF circuit configurations of AC and DC Control Boxes are described below:

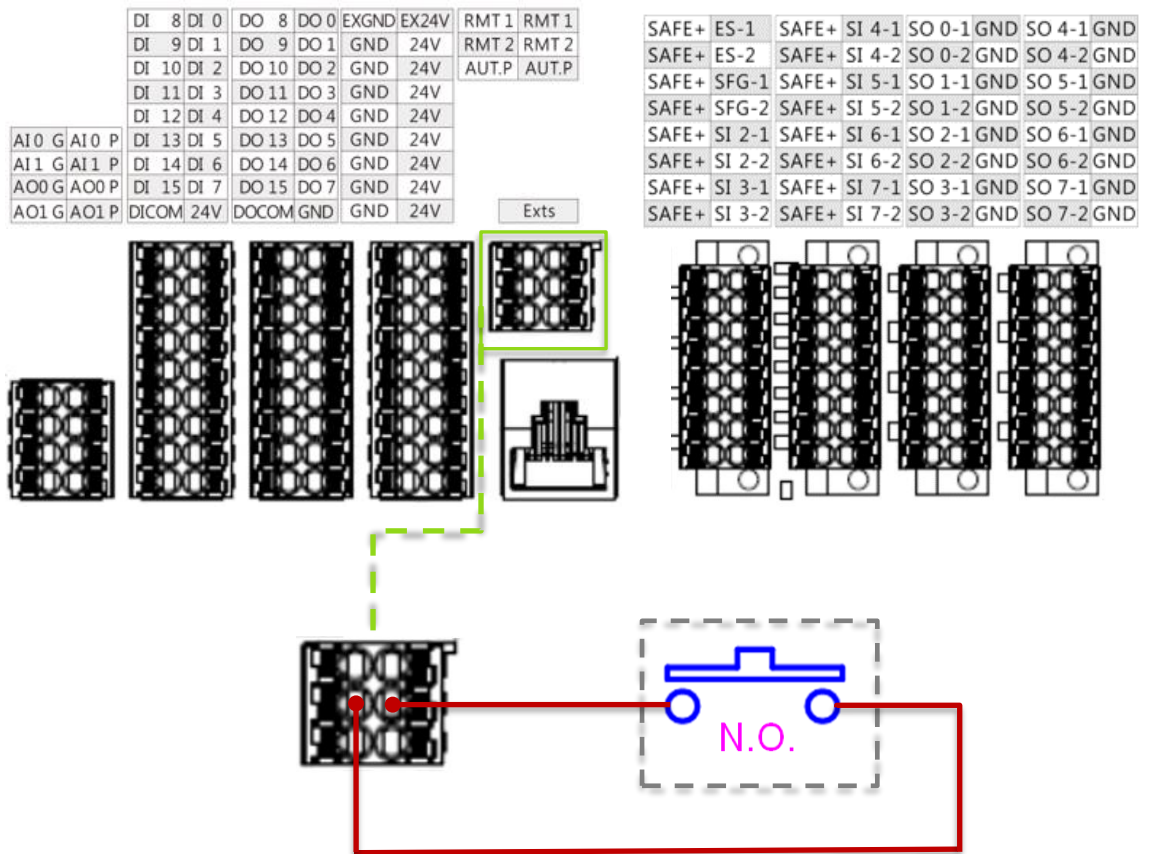


Figure 74: Remote Power ON/OFF of AC Control Box (via RMT2 interface)

The Remote Power ON/OFF of the DC Control Box requires two separate switches to operate. If only one switch is connected, the Control Box cannot start properly.

- Remote Power ON/OFF connected with push-button switches

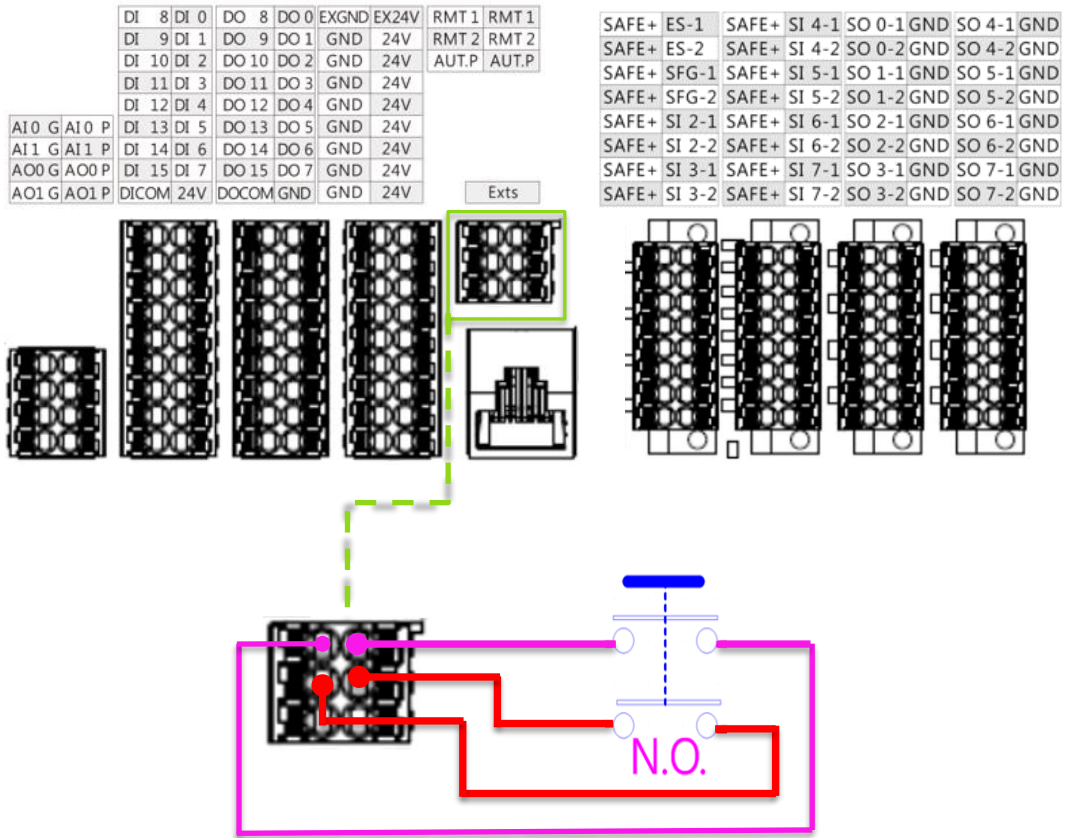


Figure 75: Remote Power ON/OFF of DC Control Box, connected with push-button switches (via RMT1 and RMT2 interfaces)

- Remote Power ON/OFF connected with a relay switch

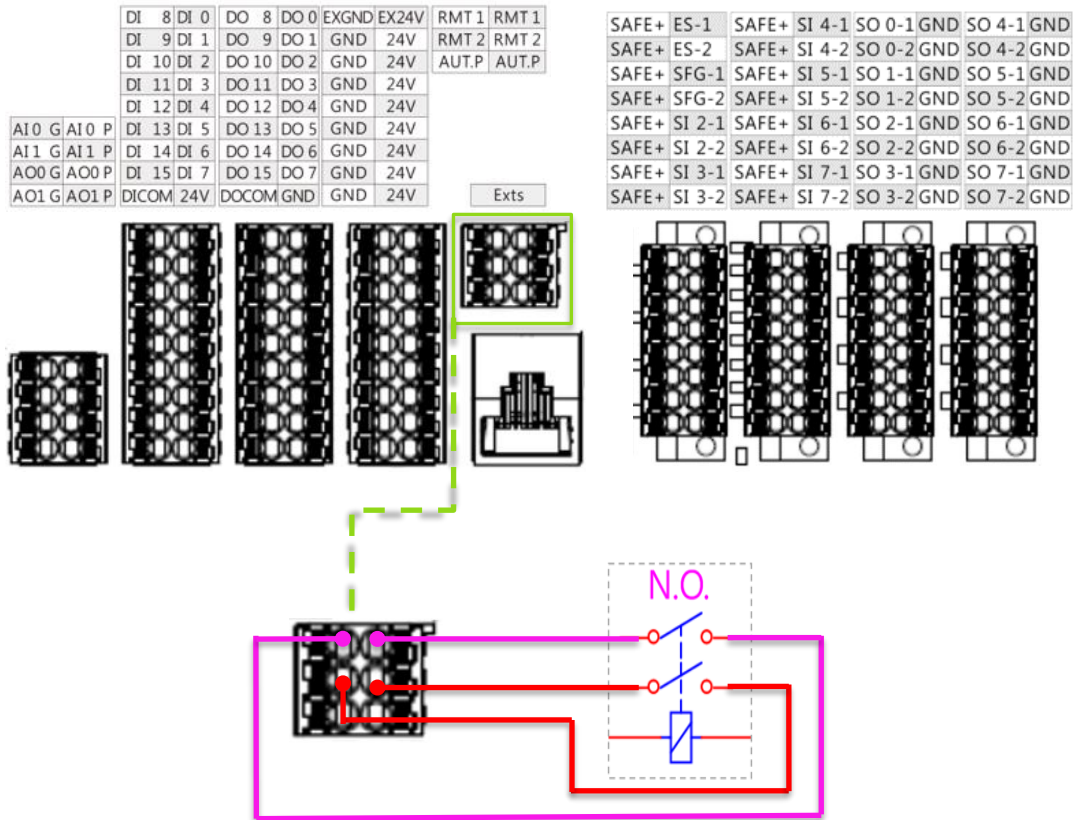


Figure 76: Remote Power ON/OFF of DC Control Box, connected with a relay switch (via RMT1 and RMT2 interfaces)

### 5.3.6 AUTO MODE Play Confirm Port

The AUTO MODE play confirm port “AUT.P” is used for connection to a push button located outside of the safeguarded space to prevent a person from executing any project near the robot under AUTO MODE.

The project can only be executed while “AUT.P” is in Close Status.

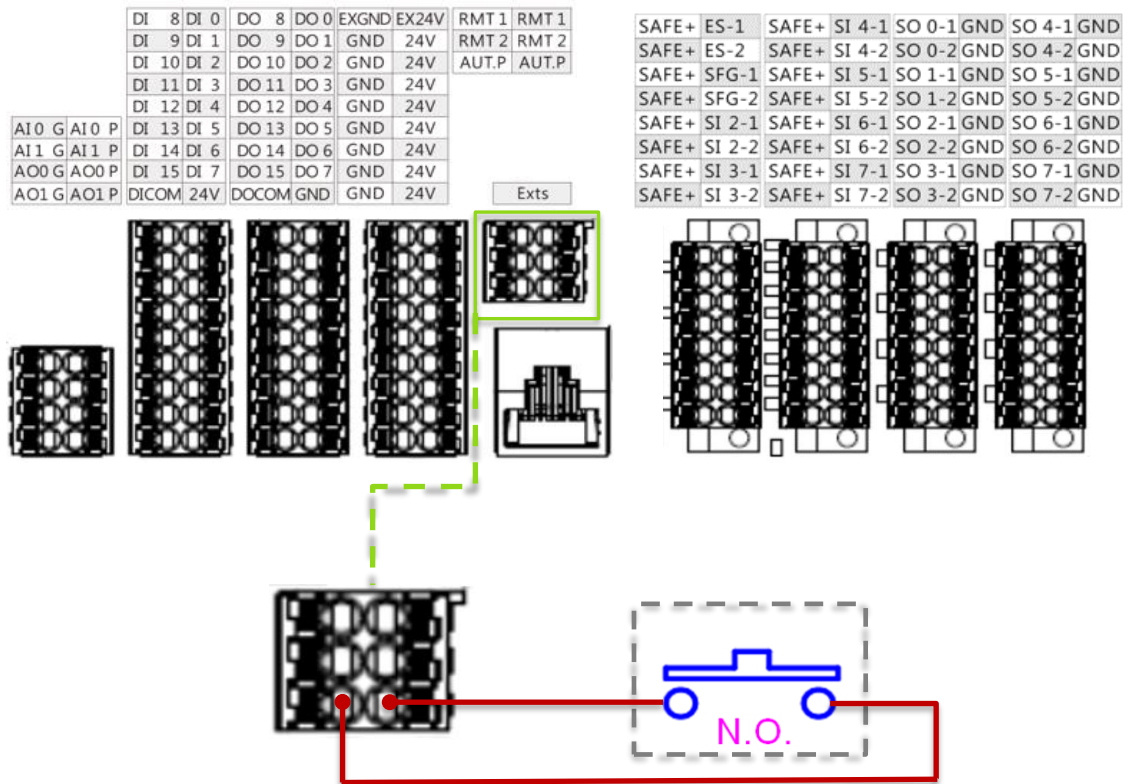


Figure 77: AUTO MODE Play Confirm Port

**WARNING:**



The additional separate confirmation action of a push button connected to “AUT.P” should be taken only when the push button is located outside the safeguarded space. This ensures that users will not execute the project near the robot. Users are still required to ensure all persons are outside the safeguarded space before activating the automatic mode and operation.

5.3.7 EtherCAT: For EtherCAT Slave I/O Expansion



Figure 78: EtherCAT

**WARNING:**



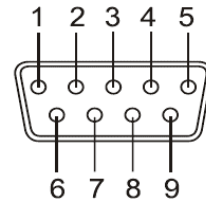
The robot must be powered off when installing the EtherCAT Slave. Do not plug or unplug the connector while the robot is on.

### 5.3.8 USB Port

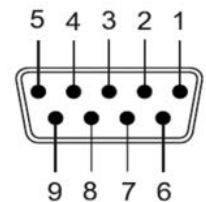
The USB port of the Control Box is used for connecting a keyboard, mouse and external storage device. External storage devices should only be used for the import/export functions of TMflow. No other device than those listed above should be connected. Be noted that the external storage device should be labelled **TMROBOT**.

### 5.3.9 COM Port

Type: DB9			
BAUD: 300 to 921600			
Pin Number	RS-232	RS-485/422 Full Duplex	RS-485 Half Duplex
1	DCD	TX-	Data-
2	RXD	TX+	Data+
3	TXD	RX+	
4	DTR	RX-	
5	GND	GND	GND
6	DSR		
7	RTS		
8	CTS		
9	RI		



Pin definition of DB9 male connector  
(from Control Box)



Pin definition of DB9 female connector  
(from the cable or device)

## 5.4 Tool End I/O Interface

There is one small connector on the tool end of the robot: The 8-pin connector can be used to configure digital I/O, analog Input, and RS485.

### 5.4.1 I/O Terminals

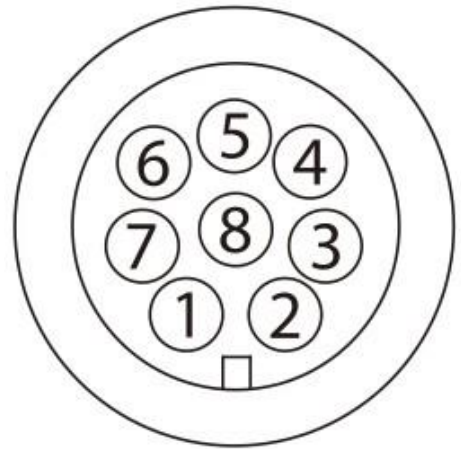
Output specifications of the tool end 24V:

Voltage:	24V	Typical:	1.5A
		Max:	2.0A (*)

(\*Do not output 2A for a duration of > 10 sec. The maximum duty cycle is limited to 10%. The average current should not exceed 1.5 A)

In the case of overloading, overload protection will be activated and the robot will turn off the 24V output power.

Pin	Wire color	Pin define	
1	Brown	+24v	24V output
2	Red	DI_0	Digital Input0
3	Orange	DI_1	Digital Input1
4	Yellow	DI_2	Digital Input2
5	Green	DO_0 AI	Digital Output0 Analog Input
6	Blue	DO_1 RS485-	Digital Output1 RS485-
7	Purple	DO_2 RS485+	Digital Output RS485+
8	Black	+0V	+0v



\*The M8/8PIN connector complies with the regulation of IEC 61076-2-104.

Table 12: 8-pin Digital I/O Connectors of Cable

Pin	Wire Color	Pin Define	
1	Brown	+24v	24V output
2	Red	DI_0	Digital input0
3	Orange	DI_1	Digital input1
4	Yellow	DI_2	Digital input2
5	Green	DO_0 AI	Digital Output0 Analog Input
6	Blue	DO_1 RS485-	Digital Output1 RS485-
7	Purple	DO_2 RS485+	Digital Output RS485+
8	Black	+0V	+0V



Table 13: 8-pin Digital I/O Connector of Robot



**NOTE:**  
While DO1 and DO2 of the end connector are set to RS485, it is the extension of COM2.

### 5.4.2 Connecting Tool End Digital Output

The following figure shows how to connect the tool end digital output:

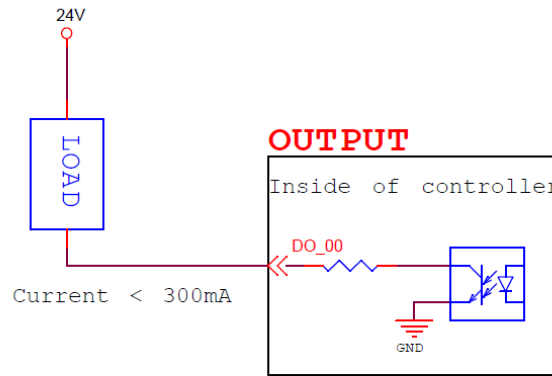


Figure 79: Connecting Tool End Digital Output

### 5.4.3 Connecting Tool End Digital Input

The following figure shows how to connect the tool end digital input:

NOTE: If sensors are connected directly then they should be NPN.

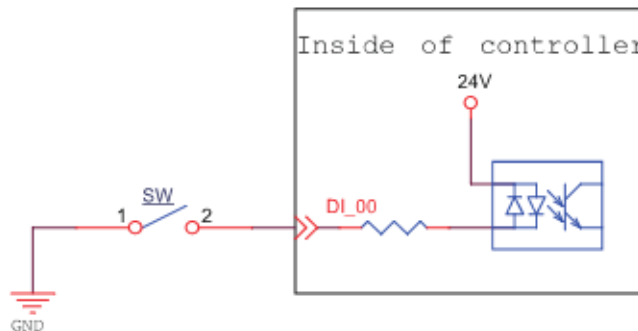


Figure 80: Connecting Tool End Digital Input

### 5.4.4 Connecting Tool End Analog Input

Range	Resolution	Accuracy	Conversion Time
+10.00V~-10.00V	11bit	≤ 0.2%	1 ms

Table 14: Analog Input Range

The following figure shows how to connect the tool end Analog input:

(Because AIN\_GND is connected to ground, when AIN is a dead contact, a pressure difference will occur, which is a normal phenomenon.)

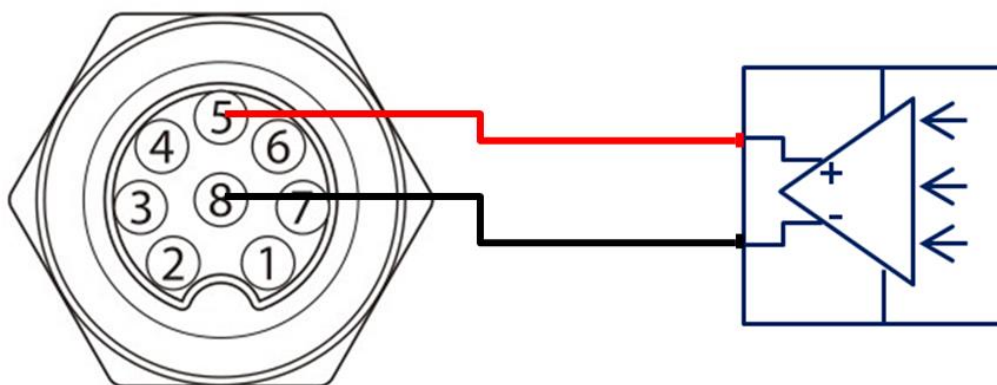


Figure 81: Connecting Tool End Analog Input

## 5.5 Control Box Interfaces

Control Box Model	Compatible Robot Model
AC	TM5S/TM5S-X TM7S/TM7S-X TM6S/TM6S-X TM12S/TM12S-X TM14S/TM14S-X TM20S/TM20S-X
DC	TM5S-M/TM5S-MX TM7S-M/TM7S-MX TM6S-M/TM6S-MX TM12S-M/TM12S-MX TM14S-M/TM14S-MX
DC SEMI	TM5S-M SEMI/TM5S-MX SEMI TM7S-M SEMI/TM7S-MX SEMI TM6S-M SEMI/TM6S-MX SEMI TM12S-M SEMI/TM12S-MX SEMI TM14S-M SEMI/TM14S-MX SEMI
Nano DC	TM5S-NM/TM5S-NMX TM7S-NM/TM7S-NMX TM6S-NM/TM6S-NMX TM12S-NM/TM12S-NMX TM14S-NM/TM14S-NMX TM20S-NM/TM20S-NMX

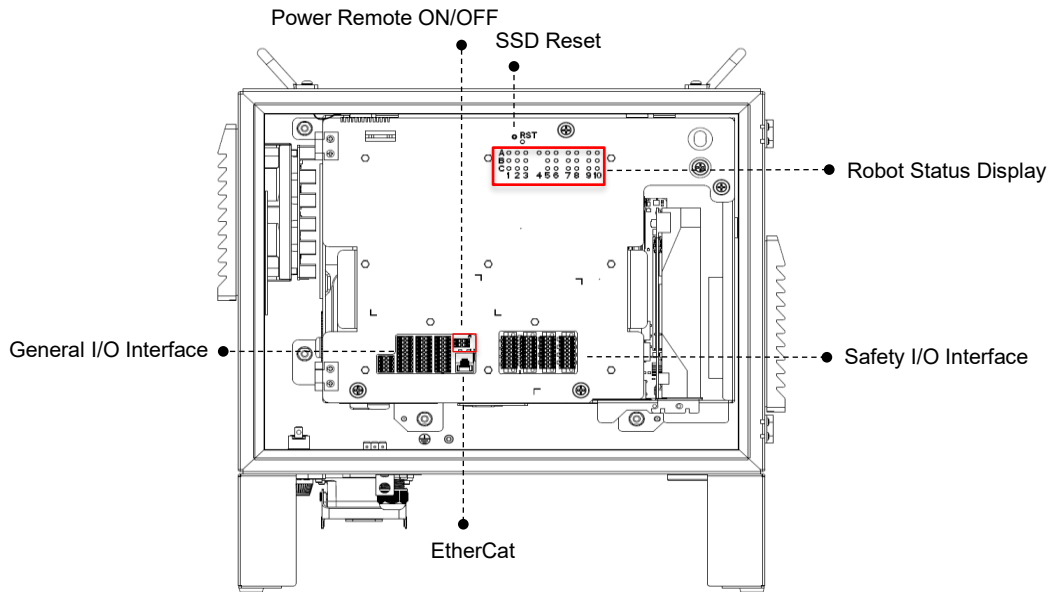


Figure 82: Front View of the Control Box (AC)

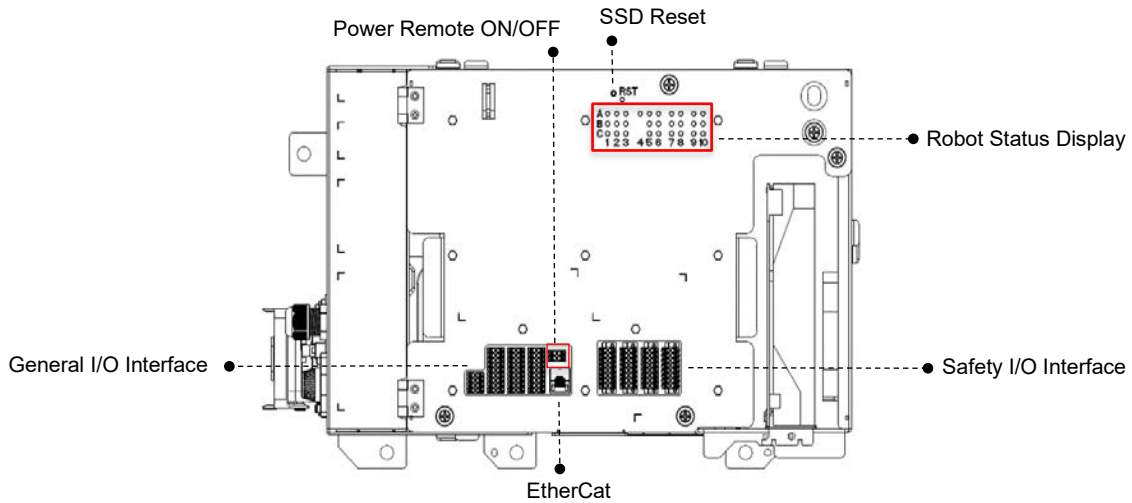


Figure 83: Front View of the Control Box (DC)

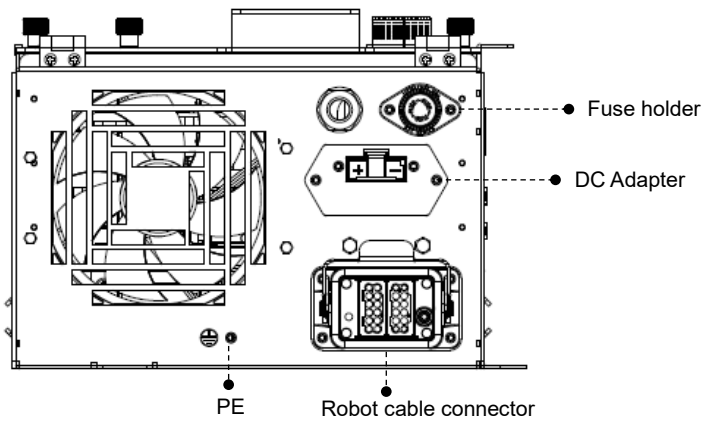


Figure 84: Side View of the Control Box (DC)

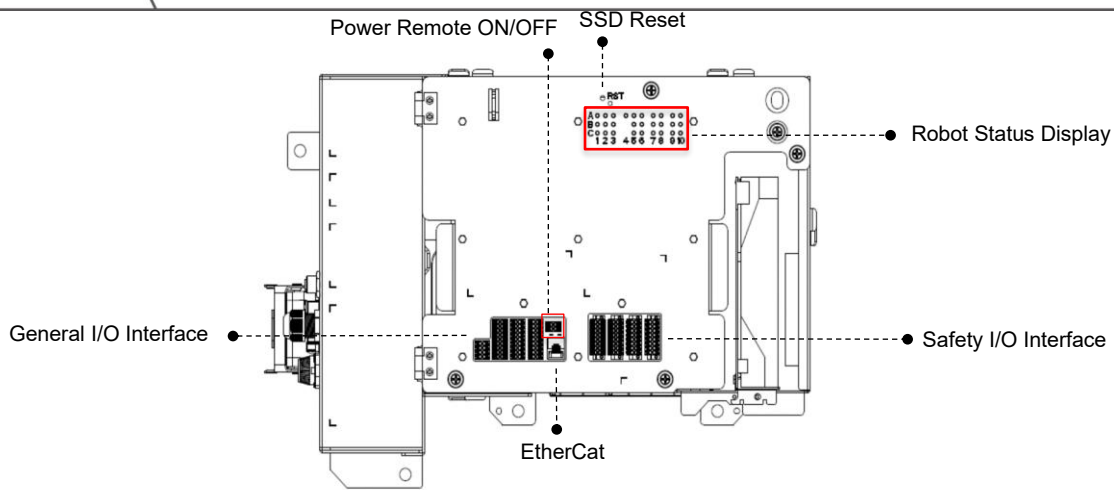


Figure 85: Front View of the Control Box (DC SEMI)

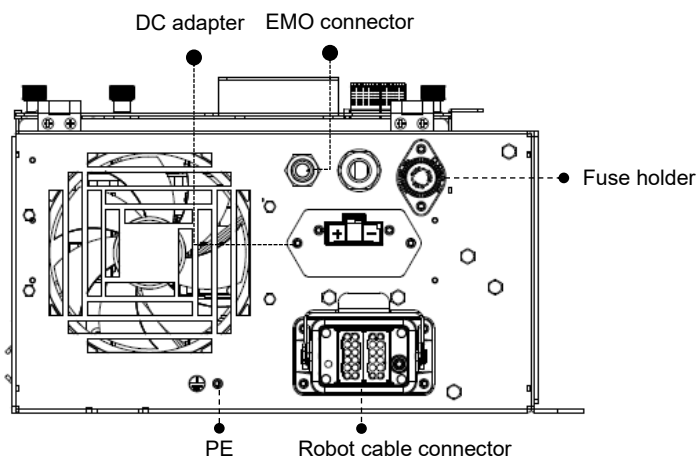


Figure 86: Side View of the Control Box (DC SEMI)



**CAUTION:**

1. The ETHERCAT interface can only be used to connect ETHERCAT devices. Improper connection may cause the robot to stop.
2. The SSD Reset button on the Control Box must only be used by a qualified or authorized individual.

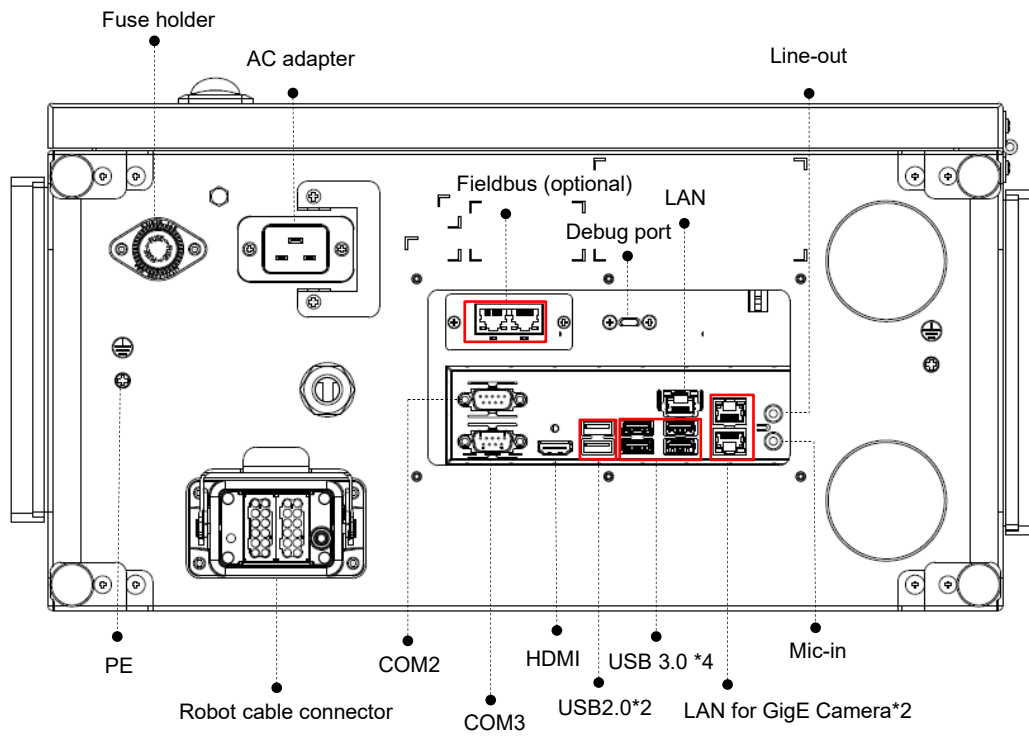


Figure 87: Interfaces of Control Box (AC)

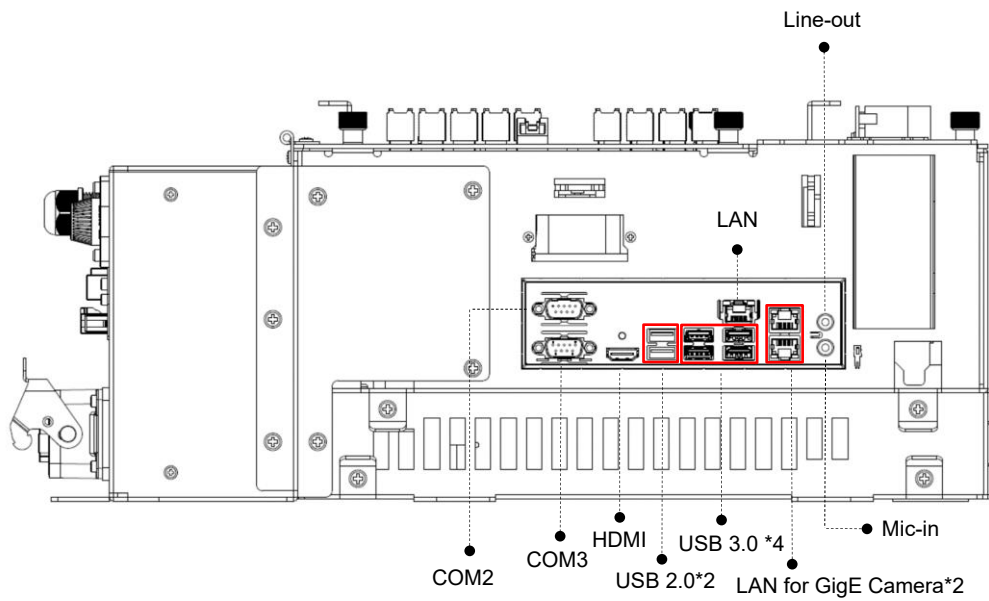


Figure 88: Interfaces of the Control Box (DC and DC SEMI)

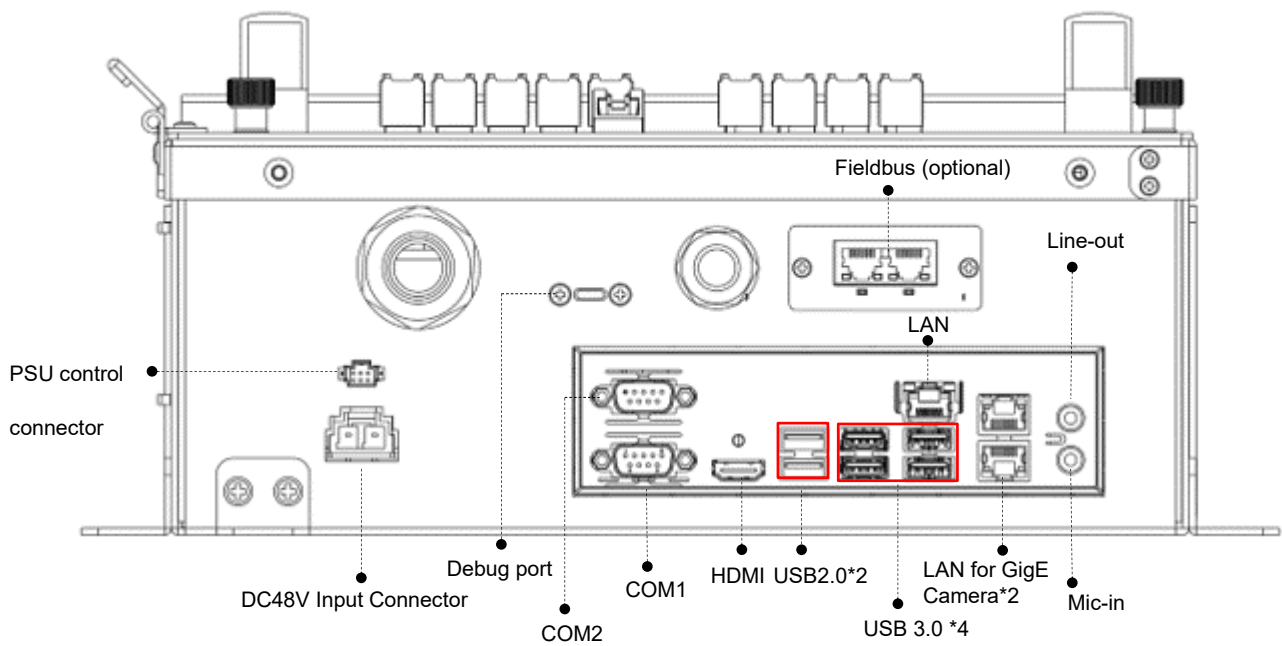


Figure 89: Interfaces of the Control Box (Nano DC)



**IMPORTANT:**

DC, DC SEMI, and Nano DC Control Boxes should be installed in an enclosure with an IP54 (or higher) protection rating.



**NOTE:**

While DO1 and DO2 of the end connector are set to RS485, it is the extension of COM2.

## 5.6 Control Box Power Interface and Robot Interface

### 5.6.1 Control Box Power Interface

AC:

The power cable of the Control Box has an IEC plug. The local power plug is connected to the IEC plug. The AC power switch must be in OFF state before plugging in or out the power cable.

DC:

The power cable of the Control Box has Hirose (HRS) DF60 series connector.

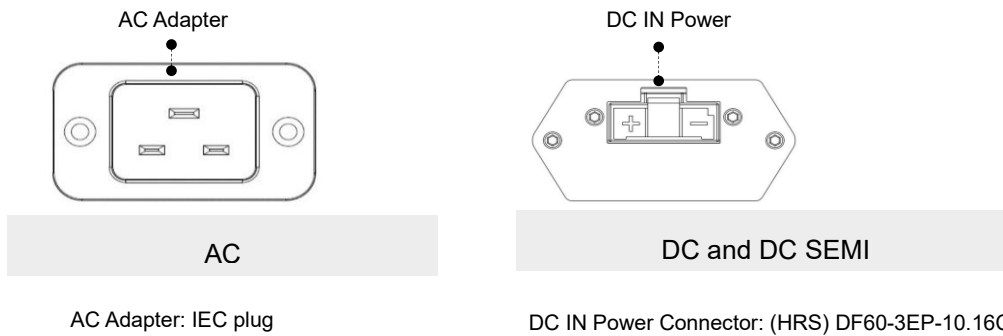


Figure 90: Control Box Power Interfaces (AC, DC, and DC SEMI)

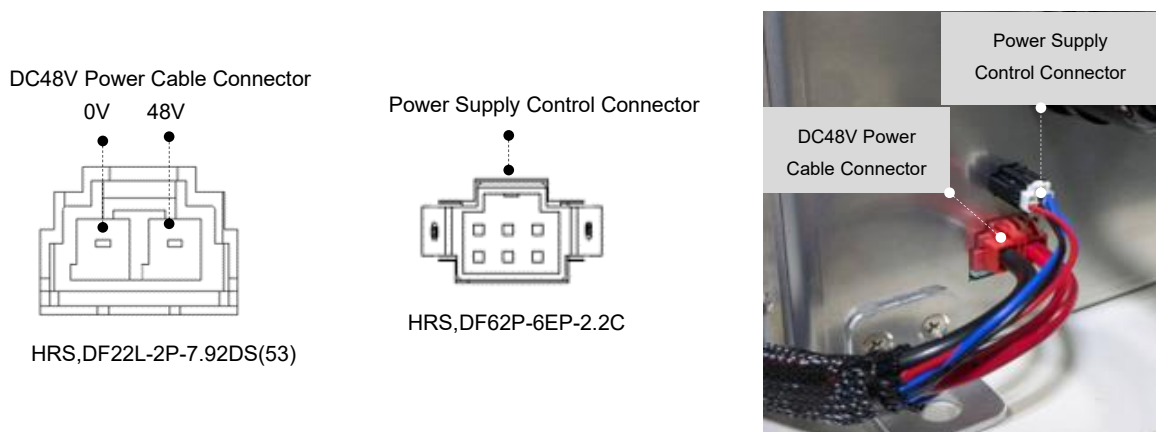


Figure 91: Control Box Power Interfaces (Nano DC)

Note

**NOTE:**

1. For the power input of the Control Box input, only use the power supply unit provided by the manufacturer and its corresponding power and control cables.
2. Make sure the power cable and control cable are both connected correctly; otherwise, the power supply unit will not work properly.



**CAUTION:**

Do not connect the DC48V power cable connector of the Nano DC Control Box to an AC power source or to any DC source above 50V. Incorrect power input may damage the Control Box.

The power supply should be equipped with the following:

- Grounding
- Main fuse
- Residual current device (RCD)

It is recommended to install a master switch on the equipment power supply for robot applications for servicing and inspection.

Parameter	Minimum value	Typical value	Maximum value	Unit
Input voltage*	100	-	240	VAC
External mains fuse (100V~120V)	-	-	15	A
External mains fuse (220V~240V)	-	-	8	A
Input frequency	47	-	63	Hz

Table 15: TM5S / TM7S / TM5S-X / TM7S-X Electrical Specifications

\*If using AC100V~AC199V power supply, the Robot will automatically limit the total output power

Parameter	Minimum value	Typical value	Maximum value	Unit
Input voltage*	100	-	240	VAC
External mains fuse (100V~120V)	-	-	15	A
External mains fuse (220V~240V)	-	-	10	A
Input frequency	47	-	63	Hz

Table 16: TM6S / TM12S / TM14S / TM20S / TM6S-X / TM12S-X / TM14S-X / TM20S-X Electrical Specifications

\*If using AC100V~AC199V power supply, the Robot will automatically limit the total output power

Parameter	Minimum Value	Typical value	Maximum value	Unit
Input voltage**	24	-	60	V (DC)
Power consumption		240	1500	W

Table 17: TM5S-M / TM7S-M / TM5S-MX / TM7S-MX Series Electrical Specifications

\*\*When using a power supply of 24 to 47V or operating at high speed, the robot will restrict the total output power.

Parameter	Minimum Value	Typical value	Maximum value	Unit
Input voltage**	24	-	60	V (DC)
Power consumption		400	1500	W

Table 18: TM6S-M / TM12S-M / TM14S-M / TM6S-MX / TM12S-MX / TM14S-MX Series Electrical Specifications

\*\*When using a power supply of 24 to 47V or operating at high speed, the robot will restrict the total output power.

Parameter	Minimum Value	Typical value	Maximum value	Unit
Input voltage	24	-	60	V (DC)
Power consumption	-	400	1000	W

Table 19: TM5S-NM / TM5S-NMX / TM7S-NM / TM7S-NMX / TM6S-NM / TM6S-NMX / TM12S-NM / TM12S-NMX / TM14S-NM / TM14S-NMX / TM20S-NM / TM20S-NMX Series Electrical Specifications (Nano DC)

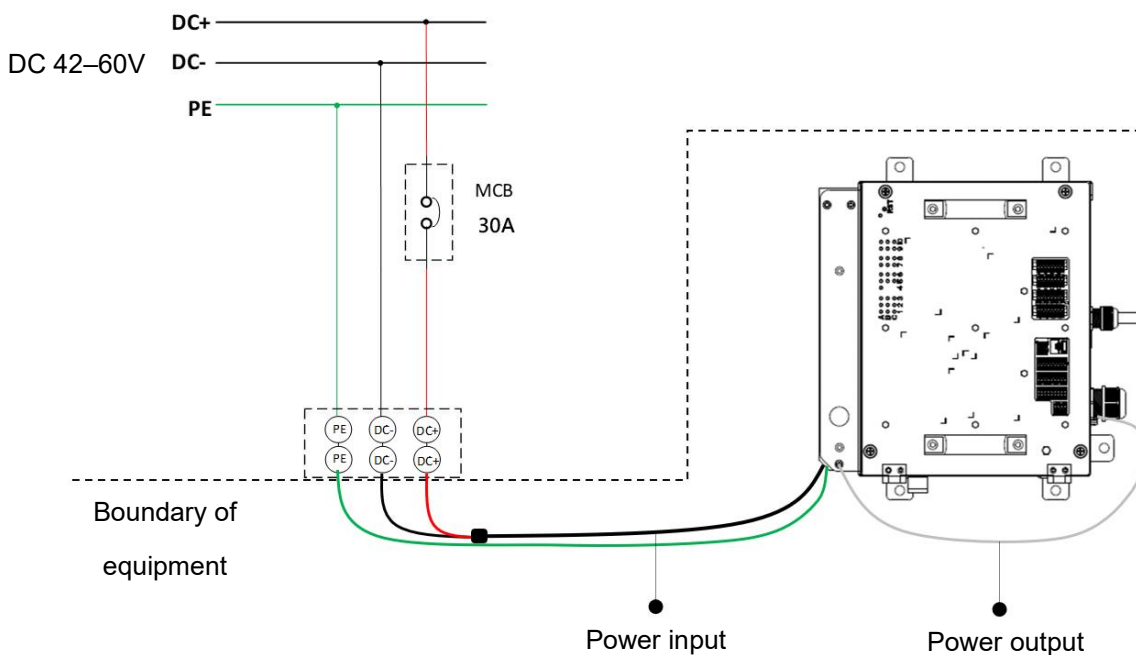


**DANGER:**

1. Ensure that the robot is correctly grounded (electrical grounding).
2. Ensure that the input current of the Control Box is protected by the Residual Current Device (RCD) and appropriate fuses.
3. Ensure that all cables are correctly connected before the Control Box is energized. Always use genuine power cables correctly.

Power installation procedures (for Nano DC only):

- with DC power supply (for Nano DC)



Note

**NOTE:**

The user should set up miniature circuit breaker (MCB), residual current device (RCD) and terminal block for Control Box power installation.



**DANGER:**

4. Ensure that the robot is correctly grounded (electrical grounding).
5. Ensure that the input current of the Control Box is protected by the RCD and appropriate fuses.
6. Ensure that all cables are correctly connected before the Control Box is energized. Always use genuine power cables correctly.

### 5.6.2 Robot Interface

The following figure shows the connection interface of the robot. The cables of the robot are connected to the Control Box through the interface.

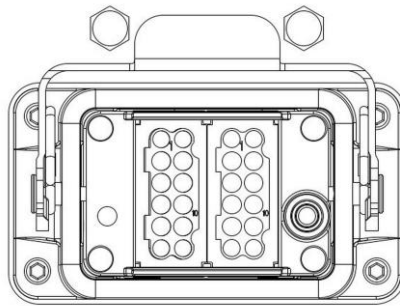


Figure 92: Robot Interface



**WARNING:**

1. When the robot is turned on, do not disconnect the cable of robot. When the cable of robot is not connected to the connection interface, do not turn on the robot.
2. Do not extend or modify the original cable of robot.
3. The cable of the robot is only suitable for a fixed installation. If the applications have the request for flexible or longer cable, contact the corporation.

### 5.6.3 SEMI Emergency Off Interfaces (SEMI series exclusive)

Refer below for the SEMI Emergency Off interfaces. The SEMI Emergency Off switch is connected with Control Box through the EMO port. Please remove the padlock on the power interface for the power cable or the power switch, and secure the padlock back to the box with the screws for shipping the box.

#### 5.6.3.1 TM5S-M SEMI / TM5S-MX SEMI / TM7S-M SEMI / TM7S-MX SEMI / TM6S-M SEMI / TM6S-MX SEMI / TM12S-M SEMI / TM12S-MX SEMI / TM14S-M SEMI / TM14S-MX SEMI Series

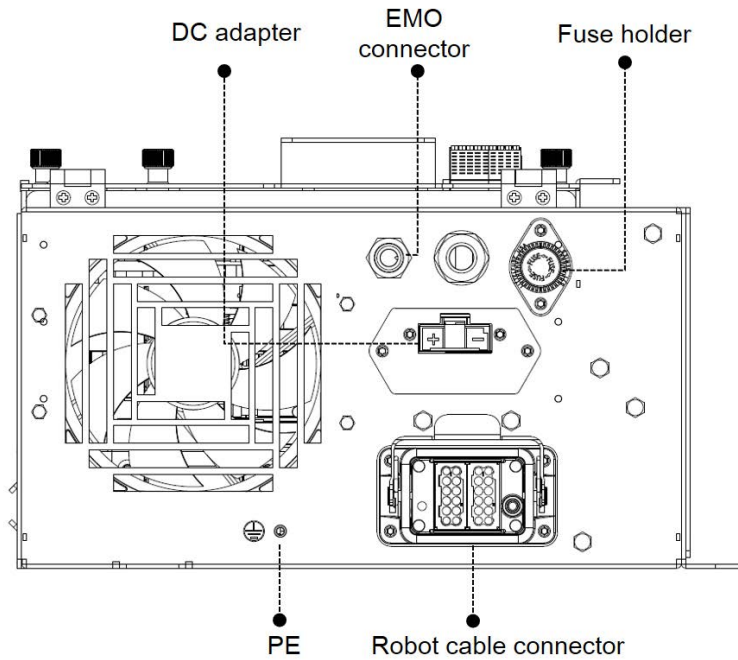


Figure 93: TM5S-M SEMI / TM5S-MX SEMI / TM7S-M SEMI / TM7S-MX SEMI / TM6S-M SEMI / TM6S-MX SEMI / TM12S-M SEMI / TM12S-MX SEMI / TM14S-M SEMI / TM14S-MX SEMI Emergency Off Interface



**CAUTION:**

For SEMI series, when SEMI Emergency Off Switch is not connected with EMO, the TM Robot cannot be booted.



**WARNING:**

When SEMI Emergency Off Switch is pressed, all power will be cut off immediately. This action impacts on the motion of the robot. Users should take with caution.

## 6. Unboxing & Installation

### 6.1 Overview

These instructions guide users of the TM Robot through the first set up. Users must thoroughly read and understand this Guide before performing the operations of this Chapter. Failure to do so may cause serious danger.



#### **WARNING:**

If this is your first time using the TM Robot, follow instructions in this chapter to perform installation and initial set up. If the robot has been implemented in the working environment, please note the following:

1. To avoid potential hazards after changing the original environment setting, verify with current responsible operator and to back up all necessary software settings and hardware wirings scheme.
2. Remove all of the Control Box's external I/O connections including the analog I/O, EtherCAT port and network port. Remove all air lines or external power lines connected to the optional equipment before Commissioning.
3. Remove all of the Control Box's connections to external devices / external storage devices through USB interface, Serial port, and network interface.
4. Unload any object/end effector attached to the robot end of the flange, and any electrical connection between the end effector and end module / Control Box of the robot.
5. Unload any hardware attached to the robot arm.

### 6.2 Inspecting the Equipment

#### 6.2.1 Before Unpacking

Carefully inspect all shipping crates for evidence of damage during transit. If any damage is indicated, request that the carrier's agent be present at the time the container is unpacked

#### 6.2.2 Upon Unpacking

Before signing the carrier's delivery sheet, compare the actual items received (not just the packing slip) with your equipment purchase order and verify that all items are present and that the shipment is correct and free of visible damage.

If the items received do not match the packing slip or are damaged, do not sign the receipt, contact your corporation support as soon as possible.

If the items received do not match your order, contact your corporation support immediately. Inspect each item for external damage as it is removed from its container. If any damage is evident, contact your corporation support (see 1.2 How Can I Get Help?).

Retain all shipping containers and packaging materials. These items may be necessary to settle claims or at a later date, to relocate equipment.

## 6.3 Unboxing

### 6.3.1 Carton Types

The TM Robot product comes with 2 cartons: the robot arm carton, and the Control Box carton, as shown below. Also, a SEMI Emergency OFF switch carton comes along with the SEMI series. For TM5S-M SEMI, TM7S-M SEMI, TM6S-M SEMI, TM12S-M SEMI or TM14S-M SEMI an additional carton comes with the SEMI Emergency OFF Box. Refer below for the ratio of the cartons. The actual sizes of the cartons may differ from measurements

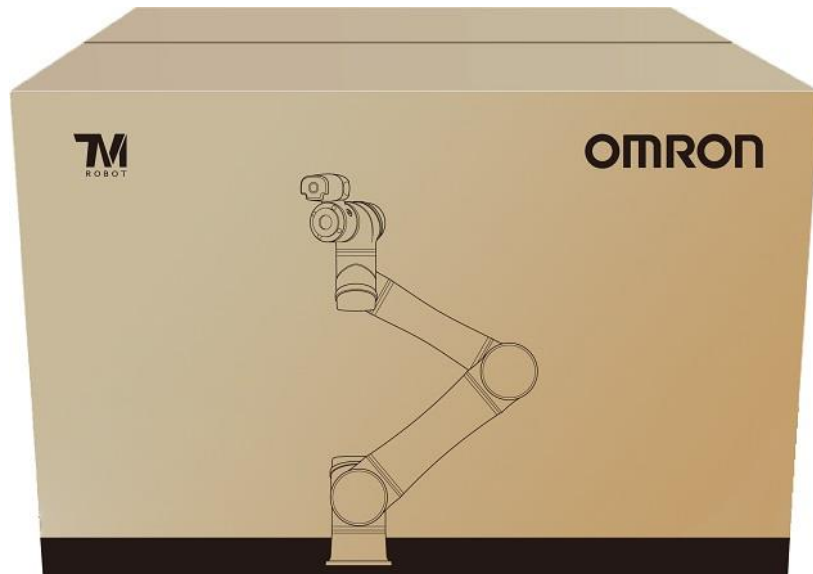


Figure 94: Robot Arm Carton

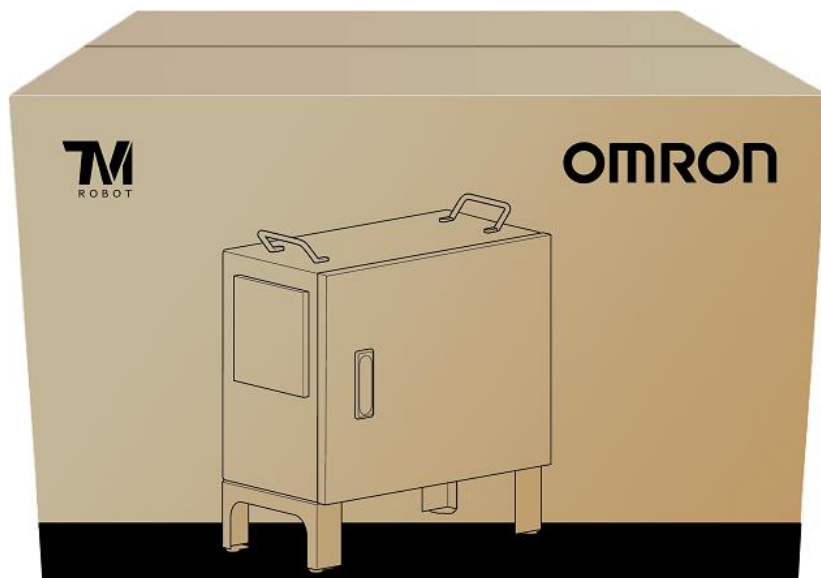


Figure 95: Control Box Carton (AC)



Figure 96: Control Box Carton (DC and DC SEMI)

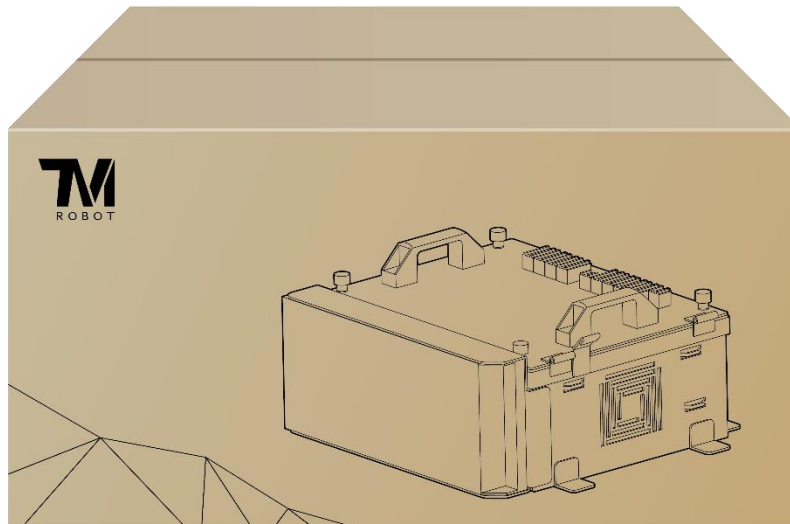


Figure 97: Nano DC Control Box Carton

### 6.3.2 Contents of Each Carton

Each carton has the following contents. Check them when you unpack the cartons for the first time. If any item is missing, contact your vendor.

The robot arm carton contains:




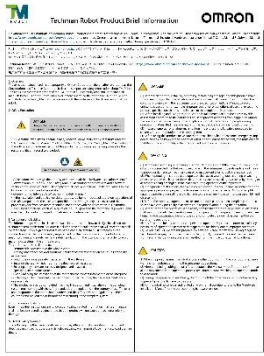
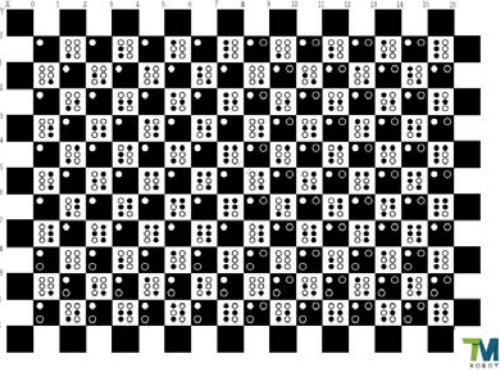




	<p style="text-align: center;"><b>Robot arm</b></p> <p>Cable length: 300 cm</p>
---	---

Table 20: The Robot Arm Carton Contents

The Control Box carton contains:

 <p>The image shows a grey rectangular control box with the OMRON logo and 'TM' on its side. A black cable is connected to the bottom of the box, leading to a black robot stick with a red emergency stop button and a power button.</p>	<p>Control Box</p> <p>Robot Stick</p> <p>Cable length: 390 cm</p>
 <p>The image shows two metal keys with black plastic heads. The heads are engraved with the OMRON logo and the text 'TM'.</p>	<p>Control box keys</p>
 <p>The image shows a document titled 'Technician Robot Product Brief information' with the OMRON logo. The document contains technical specifications, safety warnings, and installation instructions for the robot system.</p>	<p>Product Brief Information</p>

	<p style="text-align: center;"><b>Calibration Plates</b></p> <p>(Peel the protective wrap off before using.) *The Calibration Plate comes only with TM Robots fitted with the hand-eye camera.</p>
	<p style="text-align: center;"><b>IO cable</b></p> <p>(One 8-pin digital I/O cable) Length: 100 cm</p>
	<p style="text-align: center;"><b>Landmark 2.0</b></p> <p>(Two Landmarks 2.0. Peel the protective wrap off before use.) *The TM Landmark 2.0 comes only with TM Robots fitted with a hand-eye camera. Size: 50.5 * 50.5 mm (tolerance ± 0.1 mm)</p>
	<p style="text-align: center;"><b>Power cord of the Control Box</b> (TM5S / TM7S / TM6S / TM12S / TM14S / TM20S / TM5S-X / TM7S-X / TM6S-X / TM12S-X / TM14S-X / TM20S-X)</p> <p>(3 cable, Type B, G, F) Cable Length: 180 cm.</p>
	<p style="text-align: center;"><b>Power cable of the Control Box</b> (TM5S-M / TM7S-M / TM6S-M / TM12S-M / TM14S-M / TM5S-MX / TM7S-MX / TM6S-MX / TM12S-MX / TM14S-MX)</p> <p>(1 cable) Length: 120 cm</p>



	<p style="text-align: center;"><b>Ground Wire</b></p> <p>(2 wires) Length: 200 cm</p>
	<p style="text-align: center;"><b>Jumper Wire</b></p> <p>(1 pair) Wire Length: 3 cm</p>

Table 21: The Control Box Carton Contents

The SEMI Emergency OFF Switch carton contains:


	<p style="text-align: center;"><b>SEMI Emergency OFF Switch</b> (SEMI series exclusive)</p> <p>(1 pack) Cable length: 300 cm</p>
---	--

Table 22: The SEMI Emergency OFF Switch Carton Contents

#### 6.4 Installing Your Robot

The TM Robot arm cannot stand independently after being removed from the carton. Therefore, prepare the mounting base with the corresponding holes as described in 4.2.1.5 Robot Arm Installation, and follow the instructions below to install the robot.

**WARNING:**

At the installation site, at least two people should simultaneously perform installation of the robot; otherwise you risk robot arm damage or personal injury. Do not install the robot alone.

**WARNING:**

Do not attempt to move any robot links until the robot has been secured in position. Failure to comply could result in the robot falling and causing either personnel injury or equipment damage.

#### 6.4.1 Remove the Control Box

After checking the contents, remove the contents in order and perform installation.

Control Box carton:

- Remove the Landmarks
- Remove the power cable of the Control Box
- Remove the Control Box (At least two people should remove the Control Box from the carton. Refer the figure below for the correct holding positions.)
- Connect the power cable to the Control Box
- Place the Control Box near the robot base
- Mount the AC, DC, DC SEMI Control Box in any direction (as long as the box is securely mounted), with a spacing of at least 50 cm for the vents on both sides to facilitate cooling



Figure 98: Moving the Control Box (1/2)

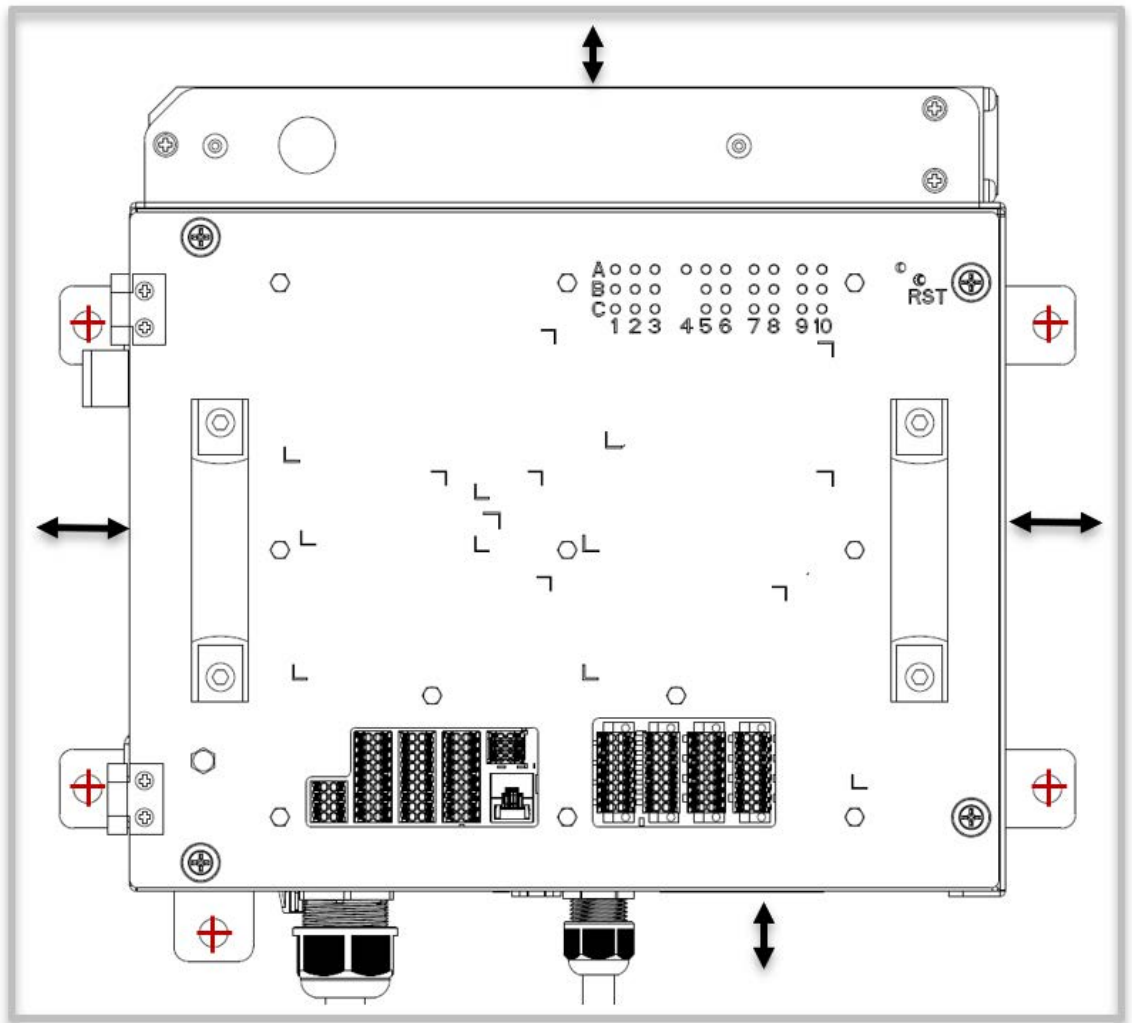
The Control Box should be carried by at least two people. One should hold on to the Control Box handles, while the other should carry the foot stands. Before handling, the cable of the robot stick should not be pulled to avoid any performance degradation.



Figure 99: Moving the Control Box (2/2)

#### Mounting a Nano DC Control Box:

- Mount the Control Box in any direction (as long as the box is securely mounted), with a spacing of at least 50 mm for the vents on both sides to facilitate cooling.
- There are five fastening points on both sides of the Control Box and they should be secured using M6, M7, or M8 screws.
- If the Control Box must be mounted inside an enclosure, to ensure the enclosure provides an airflow of > 37 CFM to facilitate cooling (please contact an authorized distributor or service center to check your setup.).



Legends:

⊕ : Mounting points

↕ : Maintain > 50 mm clearance for cooling

Figure 100: Mounting Points and Recommended Cooling Clearance for Nano DC Control Boxes



**WARNING:**

At this stage, do not connect the power cable of the Control Box to any electrical outlet, or it may cause equipment damage.

#### 6.4.2 Verification Before Removal of the Robot Arm

The TM Robot arm cannot stand independently after being removed from the carton. Prepare four screws (M10 \*4) that are used to attach the robot to the base near the robot base in advance. If the base is designed with corresponding pinholes, mount them to the base.

### 6.4.3 Removal of the Robot Arm and Tightening

At least two people should remove the robot arm from the carton. For the correct holding positions, refer to the figure below. Place the robot on the mounting base. If the mounting base is designed with connection pins, align them with the pinholes of the robot base module. Tighten two locking screws with metal washers for the robot base in a diagonal sequence, and then tighten the other two locking screws. Follow the tightening torque recommended in 4.2.1.5 Robot Arm Installation.



Figure 101: Moving the Robot Arm (1/2)

The Robot Arm itself should be handled with at least two people. One person should carry the Lower arm and Upper arm, and the other should hold on to the position between the base and 1<sup>st</sup> Joint as well as the 6<sup>th</sup> Joint. Before the Robot Base is fastened with screws tightly, the Robot Arm should always be supported to avoid tipping.



Figure 102: Moving the Robot Arm (2/2)

**WARNING:**

When the robot is installed to the base, make sure two people work together to install it. If the base is designed with pinholes, pay attention to your safety to avoid pinching. If you do not have connection parts at hand, such as the connecting pins and screws, do not leave the robot without completely tightening it (with the 4 screws completely tightened). One person should continuously support the robot arm while the other person goes to get required parts. Otherwise, the robot arm may tip, result in equipment damage or personal injury.

#### 6.4.4 Connect the Robot and the Control Box

1. Connect the cable from the robot to the robot interface of the Control Box.
2. Connect the power cable between the wall socket and the power interface of the Control Box.

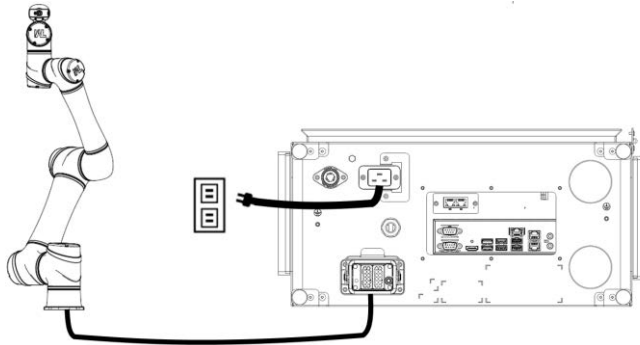
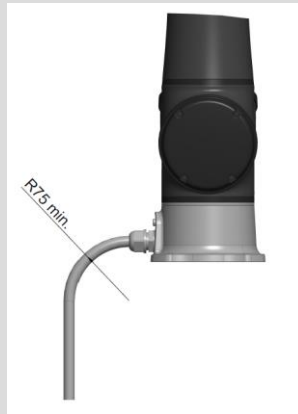


Figure 103: Connecting the Robot and the Control Box

**IMPORTANT**



**IMPORTANT:**

Please make sure the bend radius of the cable is larger than the specified value above.



**WARNING:**

1. Ensure that all cables are properly connected before supplying power to the Control Box. Always use stock power cables properly.
2. When the robot is turned on, do not disconnect cables of the robot. When cables of the robot are not connected to the connection interface, do not turn on the robot.
3. Do not extend or modify the original cables of the robot.

#### 6.4.5 Installing the Control Box and Power Supply Unit Separately (for Nano DC only)

The Control Box may be installed separately from its power supply unit, but the unit must be connected to the Control Box using the included cables.

If installed separately, secure the power supply unit for the installation environment to ensure safe and stable operation. Figure 104 describes how to install the power supply unit; make sure the screw engagement depth is  $\leq 4$  mm.

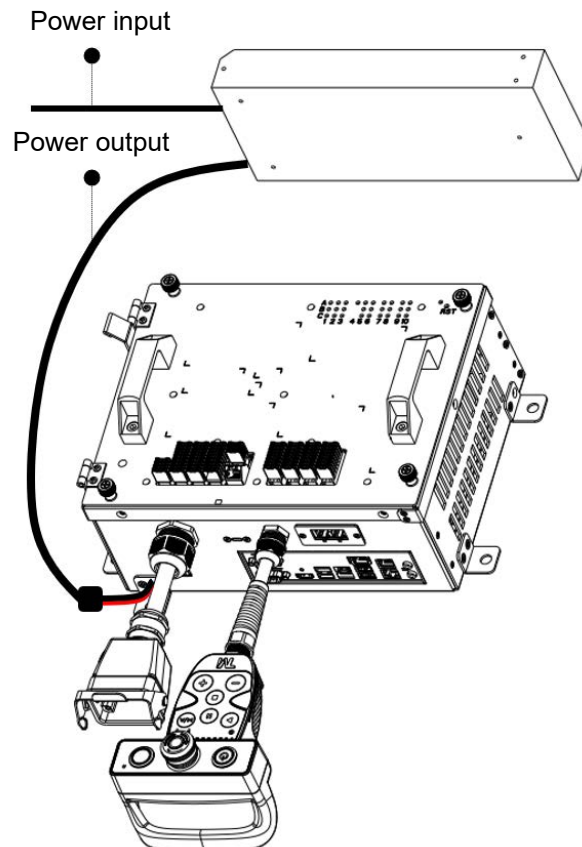


Figure 104: Connecting a Nano DC Control Box to its Power Supply Unit

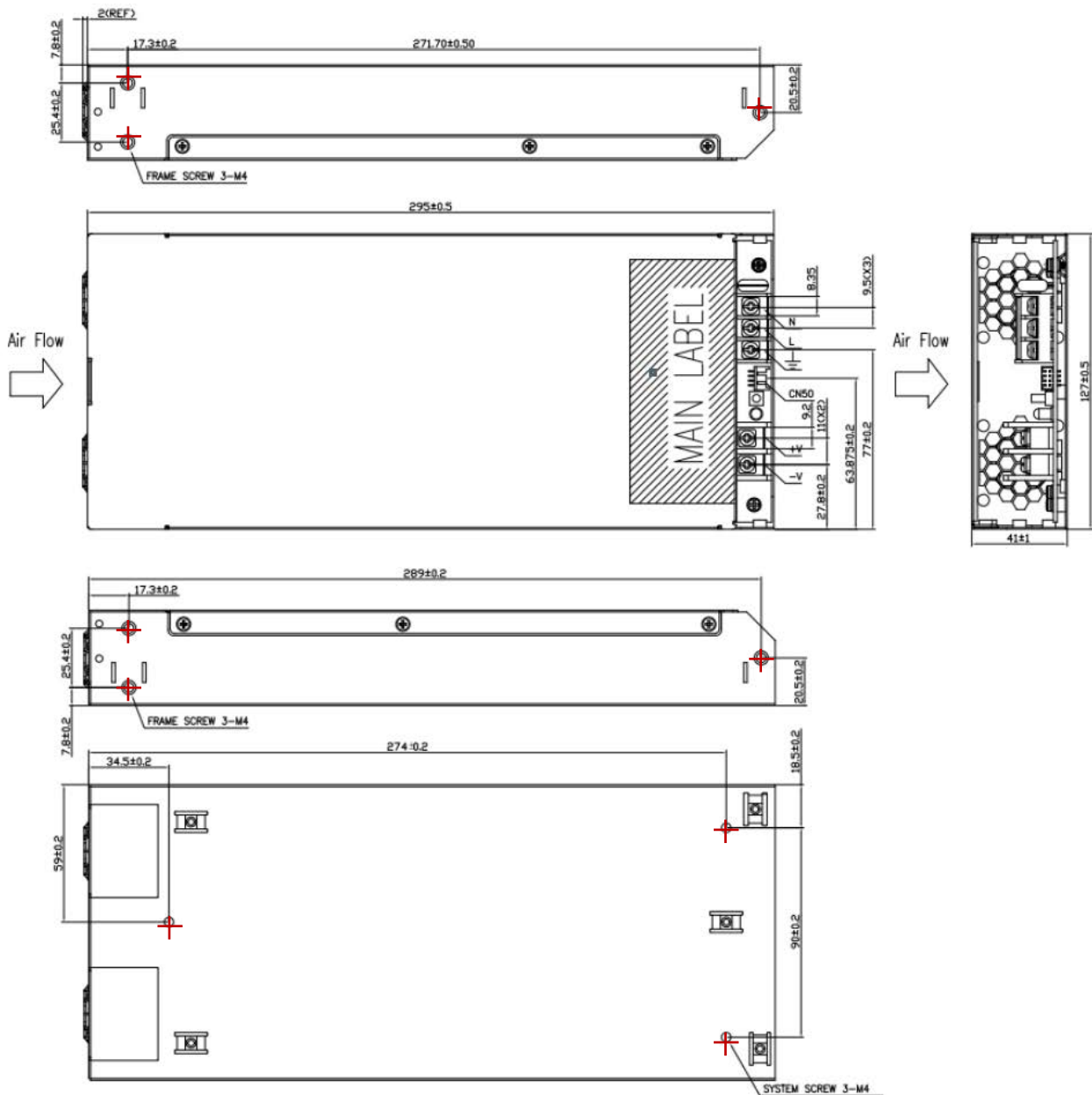


Figure 105: Mounting Holes for Nano DC Power Supply Unit

Note

**NOTE:**

1. For the power input of the Control Box input, only use the power supply unit provided by the manufacturer and its corresponding power and control cables.
2. Make sure the power cable and control cable are both connected correctly; otherwise, the power supply unit will not work properly.



**CAUTION:**

Do not connect the DC48V power cable connector of the Nano DC Control Box to an AC power source or to any DC source above 50V. Incorrect power input may damage the Control Box.

---

#### 6.4.6 Mounting Direction

Once the robot is positioned, users should, according to its application, determine its mounting direction by setting the three angles of the base frame relative to the gravity. Improper mounting direction may result in the robot moving in an unexpected way and further hitting a human body. For instructions on how to set the three angles of the base frame, please refer to *3.3.7 Mounting Direction in Omron TM Collaborative Robot: Software Manual TMFlow, Version 2 (Cat. No. I689)*.

## 7. Maintenance and Repair

The following table gives a summary of the preventive maintenance procedures and guidelines:

Items	Period	Remark
Warning, Safety labels	1 week	Ensure the labels are present and legible. Replace them if necessary.
Check Filter	1 month	Replace the filter every 3 months.
Check Emergency Stop Functions, Check Enabling Switch Functions, Check Reset Functions, Check Safeguard Functions, Check Input Functions, Check Output Functions,	1 month	Refer to <i>Omron TM Collaborative Robot S Series: Safety Manual (Cat. No. I688)</i>
Check Robot Mounting Screws	3 months	Refer to 4.2.1.5 Robot Arm Installation
EMO button (SEMI version only)	1 month	Press the EMO button to check whether power has been switched off.

Table 23: Summary of the Preventive Maintenance Procedures and Guidelines



### CAUTION:

- DO NOT remove any screws on the robot or the Control Box that require tools for removal. Otherwise, the warranty will be void.
- Only distributors or service centers authorized by the Company are allowed to repair or disassemble the TM Robot.



### DANGER:

Before performing maintenance or service record the details of each setting for the robot for normal operation. Make sure that each setting satisfies the original conditions before resuming normal operation, including but not limited to:

- Safety Software Settings
- Safety I/O
- Preset operation project
- TCP Settings
- I/O Settings
- I/O Wiring



### IMPORTANT:

After the maintenance is completed (including the change of component parts or addition of optional equipment for both hardware and software to the robot), make sure all the tests and examination listed below are carried out:

1. The functional testing of Emergency Stop functions
2. The functional testing of Safeguard functions
3. The functional testing of Enabling Switch functions
4. The functional testing of Force and Torque Limit functions
5. The functional testing of Speed Limit functions
6. The functional testing of Soft Axis Limit functions
7. The functional testing of safety output functions

The robot and the system should perform either Category 1 Stop or Category 2 Stop concerning these different safety functions. For details about the stop categories, trigger and resume method of the safety functions mentioned above, see the corresponding safety system version of the *Safety Manual*.

**NOTE:**

The filter must be replaced regularly to maintain efficiency. Please contact the Corporation to purchase the filter if in demand.



Figure 106: Air Filter Tray (the circled parts)

How to change the filter:

1. Turn off the power of the Control Box.
2. Slide the lid out of the track.



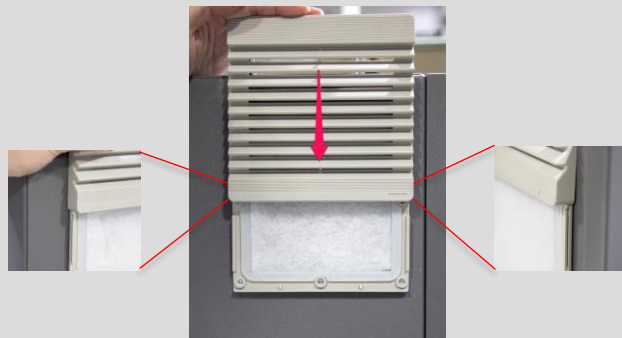
3. Remove the filter.



4. Install the new filter.



5. Align the lid on both sides of the track and slide down the lid until it stops.



# Appendix A. Technical Specifications

Model	TM5S	TM7S	TM6S	TM5S-M	TM7S-M	TM6S-M	TM5S-X	TM7S-X	TM-6X	TM5S-MX	TM7S-MX	TM6S-MX	
Weight	23.9 kg	22.9 kg	35.5kg	23.9 kg	22.9 kg	35.5kg	23.6 kg	22.6 kg	35.2 kg	23.6 kg	22.6 kg	35.2 kg	
Maximum Payload	5 kg	7 kg	6kg	5 kg	7 kg	6kg	5 kg	7 kg	6kg	5 kg	7 kg	6kg	
Reach	946 mm	758 mm	1800 mm	946 mm	758 mm	1800 mm	946 mm	758 mm	1800 mm	946 mm	758 mm	1800 mm	
Joint ranges	J1, J2, J4, J5, J6	+/- 360°											
	J3	+/- 158°	+/- 152°	+/- 166°	+/- 158°	+/- 152°	+/- 166°	+/- 158°	+/- 152°	+/- 166°	+/- 158°	+/- 152°	+/- 166°
Joint speed	J1	210°/s	130°/s	210°/s	130°/s	210°/s	130°/s	210°/s	130°/s	210°/s	130°/s	210°/s	
	J2												130°/s
	J3												210°/s
	J4	225°/s	225°/s	225°/s	225°/s	225°/s	225°/s	225°/s	225°/s	225°/s	225°/s	225°/s	
	J5												225°/s
	J6	450°/s											
Typical Speed	1.4 m/s	1.1 m/s	1.1 m/s	1.4 m/s	1.1 m/s	1.1 m/s	1.4 m/s	1.1 m/s	1.1 m/s	1.4 m/s	1.1 m/s	1.1 m/s	
Repeatability	+/- 0.03 mm		+/- 0.1 mm	+/- 0.03 mm		+/- 0.1 mm	+/- 0.03 mm		+/- 0.1 mm	+/- 0.03 mm		+/- 0.1 mm	
Degrees of freedom	6 rotating joints												
I/O Power Supply	24V 1.5A for tool												
Programming Environment	TMflow (flowchart-based), TMsript (script-based), TMcraft (developer-based)												
IP Classification	IP65												
Temperature	0 to 50°C, 85% max. ( with no condensation)												
Cleanroom Class	ISO Class 3												
Certification	TÜV-certified ISO 13849-1, ISO 10218-1, ISO/TS 15066 SGS-certified UL1740, CAN/CSA Z424-14 (R2019) CE, SEMI S2 (optional)												
<b>Control Box</b>													
I/O ports	Control Box	Analog In: 2 / Analog Out: 2 Digital In: 16 / Digital Out: 16											
	Tool Conn.	DO_0 (DO-0/AI) / DO_1 (DO-1/RS485+) / DO_2 (DO-2/RS485-) Digital In: 3 / Digital Out: 3											
I/O power supply	24V 2.0A for Control Box												
I/O Interface	2×COM, 1×HDMI, 3×LAN, 2×USB2.0, 4×USB3.0												
Temperature	0 to 50°C												
Communication	RS-232/RS-422/RS-485, Ethernet, Modbus TCP/RTU (Server & Client) PROFINET (optional), EtherNet/IP (optional)												
Regular Control Box	TM5S	TM7S	TM6S	TM5S-M	TM7S-M	TM6S-M	TM5S-X	TM7S-X	TM6S-X	TM5S-MX	TM7S-MX	TM6S-MX	
Control Box Weight	13.5 kg			8.9 kg			13.5 kg			8.9 kg			
IP Classification	IP54			N/A			IP54			N/A			
Power Supply	100–240 VAC, 50–60 Hz			24–60 VDC			100–240 VAC, 50–60 Hz			24–60 VDC			
Power	Typical	240 watts											

<b>Consumption</b>	Rated Power	250 watts (AC & DC)							
<b>Nano Control Box</b>									
<b>Nano Control box</b>			TM5S-NM	TM7S-NM	TM6S-NM		TM5S-NMX	TM7S-NMX	TM6S-NMX
<b>Control Box Weight</b>		N/A	7.2 kg			N/A	7.2 kg		
<b>Power supply</b>			24–60 VDC				24–60 VDC		
<b>IP Classification</b>			N/A				N/A		
<b>Power Consumption</b>	Typical		240 watts				240 watts		
	Rated Power		320 watts (AC & DC)				320 watts (AC & DC)		
<b>Vision</b>									
<b>Vision Application</b>	Positioning, 1D/2D Barcode Reading, OCR, Defect Detection, Measurement, Assembly Check				N/A				
<b>Positioning Accuracy</b>	2D Positioning: 0.1mm <sup>*(1)</sup>								
<b>Eye in Hand (Built in)</b>	Auto-focused color camera with 5M resolution, Working distance 100mm ~ ∞ <sup>*(2)</sup>								
<b>Eye to Hand (Optional)</b>	Support Maximum 2×GigE 2D cameras or 1×GigE 2D Camera								

<sup>\*(1)</sup>The data in this table are measured by TM laboratory and the working distance is 100 mm. It should be noted that in practical applications, the relevant values may be different due to factors such as the on-site ambient light source, object characteristics, and vision programming methods that will affect the change in accuracy.

<sup>\*\*\*(2)</sup>A Servoing vision job only uses 1.2MP.

Table 24: Technical Specifications (TM5S / TM7S / TM6S Series)

Model	TM12S	TM14S	TM20S	TM12S -M	TM14S -M	TM20S-M	TM12S- X	TM14S -X	TM-20X	TM12S -MX	TM14S -MX	TM20S-MX	
Weight	33.3 kg	33 kg	33.3kg	33.3 kg	33 kg	33.3kg	33 kg	32.7 kg	33 kg	33 kg	32.7 kg	33 kg	
Maximum Payload	12 kg	14 kg	20kg	12 kg	14 kg	20kg	12 kg	14 kg	20kg	12 kg	14 kg	20kg	
Reach	1300 mm	1100 mm	1300 mm	1300 mm	1100 mm	1300 mm	1300 mm	1100 mm	1300 mm	1300 mm	1100 mm	1300 mm	
Joint ranges	J1, J2, J4, J5, J6	+/- 360°											
	J3	+/-162°	+/-159°	+/-162°	+/-162°	+/-159°	+/-162°	+/-162°	+/-159°	+/-162°	+/-162°	+/-159°	+/-162°
Joint speed	J1	130°/s		130°/s		130°/s		130°/s		130°/s		130°/s	
	J2	95°/s		95°/s		95°/s		95°/s		95°/s		95°/s	
	J3	210°/s		125°/s		210°/s		125°/s		210°/s		125°/s	
	J4	225°/s		160°/s		225°/s		160°/s		225°/s		160°/s	
	J5	190°/s		190°/s		190°/s		190°/s		190°/s		190°/s	
	J6	450°/s		450°/s		450°/s		225°/s		450°/s		450°/s	
Typical Speed	1.3 m/s	1.1 m/s	1.1 m/s	1.4 m/s	1.1 m/s	1.1 m/s	1.4 m/s	1.1 m/s	1.1 m/s	1.4 m/s	1.1 m/s	1.1 m/s	
Repeatability	+/- 0.03 mm		+/- 0.05 mm		+/- 0.03 mm		+/- 0.05 mm		+/- 0.03 mm		+/- 0.05 mm		
Degrees of freedom	6 rotating joints												
I/O Power Supply	24V 1.5A for tool												
Programming Environment	TMflow (flowchart-based), TMscript (script-based), TMcraft (developer-based)												
IP Classification	IP65												
Temperature	0 to 50°C, 85% max. ( with no condensation)												
Cleanroom Class	ISO Class 3												
Certification	TÜV-certified ISO 13849-1, ISO 10218-1, ISO/TS 15066 SGS-certified UL1740, CAN/CSA Z424-14 (R2019) CE, SEMI S2 (optional)												
<b>Control Box</b>													
I/O ports	Control Box	Analog In: 2 / Analog Out: 2 Digital In: 16 / Digital Out: 16											
	Tool Conn.	DO_0 (DO-0/AI) / DO_1 (DO-1/RS485+) / DO_2 (DO-2/RS485-) Digital In: 3 / Digital Out: 3											
I/O power supply	24V 2.0A for Control Box												
I/O Interface	2×COM, 1×HDMI, 3×LAN, 2×USB2.0, 4×USB3.0												
Temperature	0 to 50°C												
Communication	RS-232/RS-422/RS-485, Ethernet, Modbus TCP/RTU (Server & Client) PROFINET (optional), EtherNet/IP (optional)												
Regular Control Box	TM12S	TM14S	TM20S	TM12S -M	TM14S -M	N/A	TM12S- X	TM14S -X	TM-20X	TM12S -MX	TM14S -MX	N/A	
Control Box Weight	13.5 kg			8.9 kg			13.5 kg			8.9 kg			
IP Classification	IP54			N/A			IP54			N/A			
Power Supply	100–240 VAC, 50–60 Hz			24–60 VDC			100–240 VAC, 50–60 Hz			24–60 VDC			
Power Consumption	Typical	400 watts						400 watts					
	Rated Power	AC: 450 watts DC: 260 watts						AC: 450 watts DC: 260 watts					

Nano Control Box									
Nano Control box		N/A			TM12S -NM	TM14S -NM	TM20S-NM	N/A	
					TM12S -NMX	TM14S -NMX	TM20S-NM X		
Control Box Weight					7.2 kg			7.2 kg	
Power supply					24–60 VDC			24–60 VDC	
IP Classification					N/A			N/A	
Power Consumption	Typical				240 watts			240 watts	
	Rated Power				455 watts			455 watts	
Vision									
Vision Application		Positioning, 1D/2D Barcode Reading, OCR, Defect Detection, Measurement, Assembly Check				N/A			
Positioning Accuracy		2D Positioning: 0.1mm <sup>*(1)</sup>							
Eye in Hand (Built in)		Auto-focused color camera with 5M resolution, Working distance 100mm ~ $\infty$ <sup>*(2)</sup>							
Eye to Hand (Optional)		Support Maximum 2×GigE 2D cameras or 1×GigE 2D Camera							

<sup>\*(1)</sup>The data in this table are measured by TM laboratory and the working distance is 100 mm. It should be noted that in practical applications, the relevant values may be different due to factors such as the on-site ambient light source, object characteristics, and vision programming methods that will affect the change in accuracy.

<sup>\*(2)</sup>A Servoing vision job only uses 1.2MP.

Table 25: Technical Specifications (TM12S / TM14S / TM20S Series)

**THIS DOCUMENT CONTAINS IMPORTANT SAFETY INSTRUCTIONS. SAVE THIS DOCUMENT.**

**OMRON Corporation Industrial Automation Company**

**Kyoto, JAPAN**

**Contact : [www.ia.omron.com](http://www.ia.omron.com)**

**Regional Headquarters**

**OMRON EUROPE B.V.**

Wegalaan 67-69, 2132 JD Hoofddorp  
The Netherlands  
Tel: (31) 2356-81-300 Fax: (31) 2356-81-388

**OMRON ASIA PACIFIC PTE. LTD.**

438B Alexandra Road, #08-01/02 Alexandra  
Technopark, Singapore 119968  
Tel: (65) 6835-3011 Fax: (65) 6835-3011

**OMRON ELECTRONICS LLC**

2895 Greenspoint Parkway, Suite 200  
Hoffman Estates, IL 60169 U.S.A.  
Tel: (1) 847-843-7900 Fax: (1) 847-843-7787

**OMRON ROBOTICS AND SAFETY TECHNOLOGIES, INC.**

4225 Hacienda Drive, Pleasanton, CA 94588 U.S.A.  
Tel: (1) 925-245-3400 Fax: (1) 925-960-0590

**OMRON (CHINA) CO., LTD.**

Room 2211, Bank of China Tower, 200 Yin Cheng Zhong Road,  
PuDong New Area, Shanghai, 200120, China  
Tel: (86) 21-6023-0333 Fax: (86) 21-5037-2388

**Authorized Distributor:**

©OMRON Corporation 2025-2026 All Rights Reserved.  
In the interest of product improvement, specifications are  
subject to change without notice.

**Cat. No. M135-E-02** 0526 (1025)

25745-000B