

SYSMAC
CS1W-CLK13 (H-PCF Cable)
CS1W-CLK12-V1 (H-PCF Cable)
CVM1-CLK12 (H-PCF Cable)
CS1W-CLK53 (GI Cable)
CS1W-CLK52-V1 (GI Cable)
CVM1-CLK52 (GI Cable)

Optical Ring Controller Link Units

OPERATION MANUAL

OMRON

CS1W-CLK13 (H-PCF Cable)

CS1W-CLK12-V1 (H-PCF Cable)

CVM1-CLK12 (H-PCF Cable)

CS1W-CLK53 (GI Cable)

CS1W-CLK52-V1 (GI Cable)

CVM1-CLK52 (GI Cable)

Optical Ring Controller Link Units

Operation Manual

Revised June 2008

Notice:

OMRON products are manufactured for use according to proper procedures by a qualified operator and only for the purposes described in this manual.

The following conventions are used to indicate and classify precautions in this manual. Always heed the information provided with them. Failure to heed precautions can result in injury to people or damage to property.

 **DANGER** Indicates an imminently hazardous situation which, if not avoided, will result in death or serious injury. Additionally, there may be severe property damage.

 **WARNING** Indicates a potentially hazardous situation which, if not avoided, could result in death or serious injury. Additionally, there may be severe property damage.

 **Caution** Indicates a potentially hazardous situation which, if not avoided, may result in minor or moderate injury, or property damage.

OMRON Product References

All OMRON products are capitalized in this manual. The word “Unit” is also capitalized when it refers to an OMRON product, regardless of whether or not it appears in the proper name of the product.

The abbreviation “Ch,” which appears in some displays and on some OMRON products, often means “word” and is abbreviated “Wd” in documentation in this sense.

The abbreviation “PLC” means Programmable Controller. “PC” is used, however, in some Programming Device displays to mean Programmable Controller.

Visual Aids

The following headings appear in the left column of the manual to help you locate different types of information.

Note Indicates information of particular interest for efficient and convenient operation of the product.

1,2,3... 1. Indicates lists of one sort or another, such as procedures, checklists, etc.

Unit Versions of CS-series Controller Link Units

Unit Versions

A “unit version” has been introduced to manage CS-series Controller Link Units according to differences in functionality accompanying upgrades.

Unit Version Notation on Products

The unit version code is provided on the nameplate of the CS-series Controller Link Units for which unit versions are being managed. This system applies to Controller Link Units with unit version 1.2 or later.

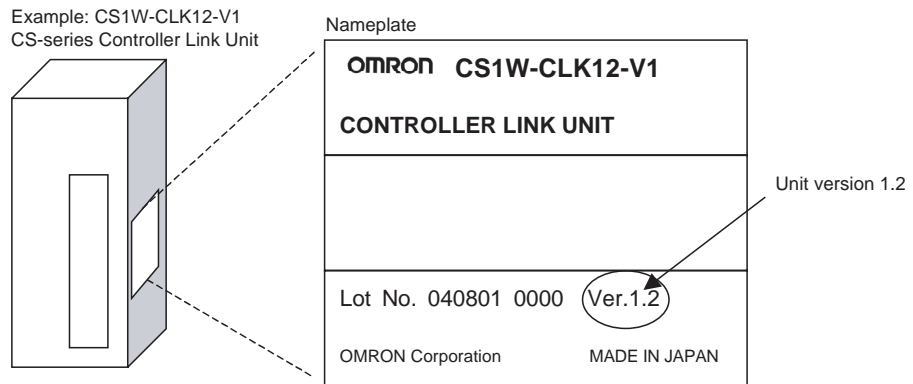

Confirming Unit Versions with Support Software

CX-Programmer version 5.0 or later can be used to confirm the unit version in the *Unit Manufacturing Information*.

- 1,2,3... 1. In the I/O Table Window, right-click on the Controller Link Unit, and then select **Unit Manufacturing Information**.
2. The following Unit Manufacturing Information Dialog Box will be displayed.

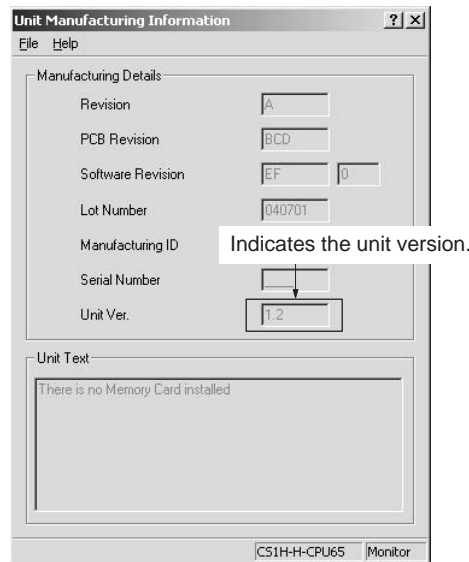

Example: In this Unit Manufacturing Information Dialog Box, unit version 1.2 is displayed. Use this dialog box to confirm the unit version of the Controller Link Unit that is connected online.

Using the Unit Version Labels

Unit version labels are provided with the product. These labels can be attached to the front of previous Controller Link Units to differentiate between Controller Link Units of different unit versions.

Unit Version Notation

The unit versions are indicated in this manual as follows:

Notation in product nameplate	Notation in this manual	Remarks
Ver.1.2 or later after the lot number	CS-series Controller Link Units with unit version 1.2 or later	Information for which no particular version is specified applies to all unit versions.
Blank after the lot number	Pre-Ver. 1.2 CS-series Controller Link Units	

Function Support by Unit Version

Functions	Unit version 2.0	Unit version 1.2	Earlier version (Pre-Ver. 1.2)
	CS1W-CLK13 CS1W-CLK53	CS1W-CLK12-V1 CS1W-CLK52-V1	CS1W-CLK12-V1 CS1W-CLK52-V1
Maximum number of data link words (data link area for sending/receiving that is created for a single node in a single CPU Unit)	20,000 max. (See note 1.)		12,000 max.
Number of send words per node (total of area 1 and area 2)	4,000 words max. (See note 2.)	1,000 words max.	
Data Link Area	The same area can be allocated for both Area 1 and Area 2.		The same area cannot be allocated for both Area 1 and Area 2.
Maximum number of Units connected to a single CPU Unit	8 Units		4 Units
Number of error log records	64 records max.		39 records max.

- Note**
1. Use the CX-Net in CX-Programmer version 5.0 or later to set a data link area in which the number of send and receive words exceeds 12,000 words, or to set data link tables that allocate the same area for Area 1 and Area 2.
 2. Use the CX-Integrator Data Link Setting Tool version 3.2.1.1 or later to set data link tables with more than 1,000 send words per node. For information on checking the version number, refer to *Checking the CX-Integrator Data Link Setting Tool Version on page viii*.

Unit Versions and Manufacturing Dates/Lot Numbers

Model	Until July 2004	From August 2004	From September 2007
CS1W-CLK12-V1	Pre-Ver. 1.2	Unit version 1.2 (Lot No. 040801 and later)	
CS1W-CLK52-V1			
CS1W-CLK13	---	---	Unit version 2.0
CS1W-CLK53			

Checking the CX-Integrator Data Link Setting Tool Version

- 1,2,3... 1. Start the CX-Integrator and select **Tool - Start Data Link**.

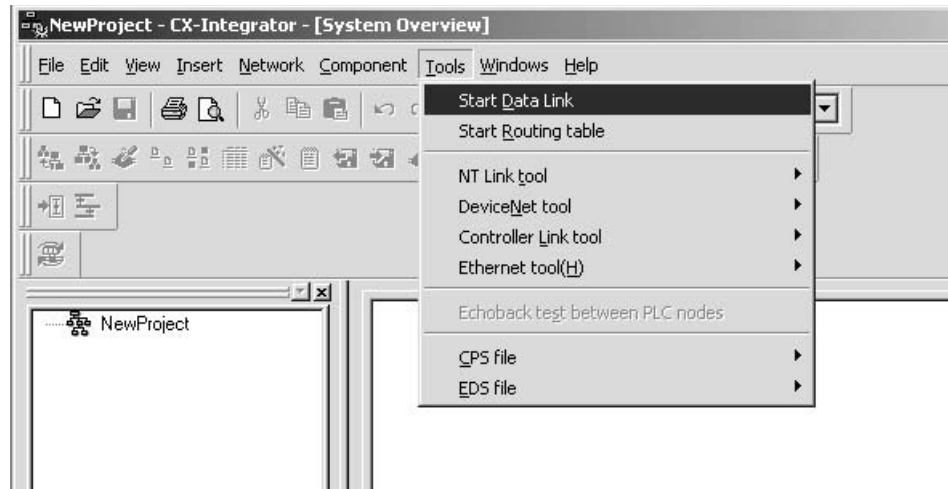

2. In the Select Network Dialog Box, select **1 Controller Link** and click the **OK** Button.

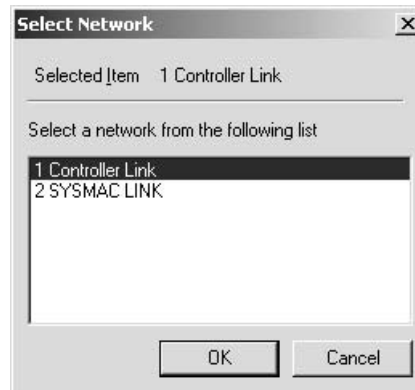

3. The Data Link Table Setting Tool (Data Link Component) will start. Select **Help - About Datalink Component...**

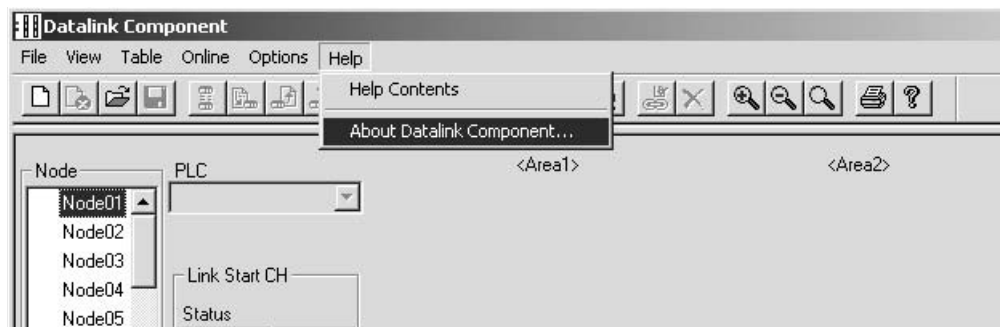

4. The Version Dialog Box will be displayed. Check the Data Link Component version number.

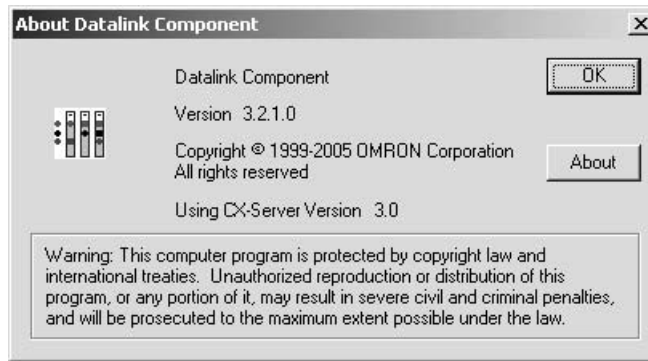

If CX-One version 2.0 or later Support Software is being used with an older version of the Data Link Component, use the CX-One automatic update function to upgrade to the latest version.

© OMRON, 2000

All rights reserved. No part of this publication may be reproduced, stored in a retrieval system, or transmitted, in any form, or by any means, mechanical, electronic, photocopying, recording, or otherwise, without the prior written permission of OMRON.

No patent liability is assumed with respect to the use of the information contained herein. Moreover, because OMRON is constantly striving to improve its high-quality products, the information contained in this manual is subject to change without notice. Every precaution has been taken in the preparation of this manual. Nevertheless, OMRON assumes no responsibility for errors or omissions. Neither is any liability assumed for damages resulting from the use of the information contained in this publication.

TABLE OF CONTENTS

PRECAUTIONS	xxi
1 Intended Audience	xxii
2 General Precautions	xxii
3 Safety Precautions	xxii
4 Operating Environment Precautions	xxiii
5 Applications Precautions	xxiv
6 Conformance to EC Directives	xxvi
SECTION 1	
Features and System Configuration	1
1-1 Overview	2
1-2 Specifications and Configurations	13
1-3 Selecting Communications Functions	30
1-4 Basic Procedures	30
1-5 Application Precautions	31
SECTION 2	
Basic Procedures	35
2-1 Data Links Procedures	36
2-2 Message Service Procedure	44
SECTION 3	
Installation and Wiring	47
3-1 Component Names and Functions	48
3-2 Installation	59
3-3 Optical Wiring	63
SECTION 4	
Preparations for Communications	75
4-1 CS-series Optical Ring Controller Link Units	76
4-2 CVM1 and CV-series Optical Ring Controller Link Units	79
SECTION 5	
Data Links	85
5-1 What Are Data Links?	86
5-2 Setting Data Links	94
5-3 Starting and Stopping Data Links	127
5-4 Checking Data Link Status	130

TABLE OF CONTENTS

SECTION 6

Message Service	141
6-1 Introduction	142
6-2 Selecting Communications Instructions	152
6-3 Using the Message Service	154
6-4 FINS Commands and Responses	160
6-5 Commands and Responses for Controller Link Units	162
6-6 Response Codes	177

SECTION 7

Network Interconnections	185
7-1 What is Network Interconnection?	186
7-2 Remote Programming and Monitoring	188
7-3 Routing Tables	190
7-4 Setting Routing Tables	192

SECTION 8

Duplex Communications Units	199
8-1 Overview	200
8-2 Duplex Unit System Configuration	202
8-3 Procedure for Using Duplex Units	204
8-4 Precautions for Duplex Systems	210
8-5 Switching Time for Duplex Units	212
8-6 Auxiliary Area Bits/Words and PLC Setup Settings Related to Duplex Communications Units	214

SECTION 9

Communications Timing	217
9-1 Communications Mechanism	218
9-2 Communications Cycle Time	221
9-3 Data Link I/O Response Time	224
9-4 Message Delay Times	230

SECTION 10

Troubleshooting and Maintenance	235
10-1 Troubleshooting Using Indicators	236
10-2 Status Area and Troubleshooting	247
10-3 Error Log	260
10-4 Troubleshooting Error Messages	268
10-5 Locating and Correcting Cable Disconnections	270
10-6 Troubleshooting for Duplex Communications Units	284
10-7 Cleaning and Inspection	287
10-8 Handling Precautions	288

TABLE OF CONTENTS

SECTION 11

Adding Nodes and Editing Active Data Link Tables. 299

11-1 Adding Nodes in Token-ring Mode 300

11-2 Changing the Data Link Tables with Active Data Links 303

Appendices

A Memory Areas 309

B Standard Models 323

C CS-series Optical Bus Controller Link Units 327

D Handling and Using GI Cable 333

Index. 337

Revision History 341

About this Manual:

This manual describes the installation, setup, and operation of the CS1W-CLK13, CS1W-CLK12-V1, CVM1-CLK12, CS1W-CLK53, CS1W-CLK52-V1, and CVM1-CLK52 Optical Ring Controller Link Units for CS-series, CVM1, and CV-series PLCs and includes the sections described below. The Controller Link Units are used to connect these PLCs to an Optical Ring Controller Link Network. The following three manuals are related to application of the Controller Link Network.

Name	Contents	Cat. No. (suffixes omitted)
CS1W-CLK13, CS1W-CLK12-V1, CVM1-CLK12, CS1W-CLK53, CS1W-CLK52-V1, CVM1-CLK52 Optical Ring Controller Link Units Operation Manual (this manual)	Installation, setup, and operating procedures for the Optical Ring Controller Link Units. Controller Link Units are used to connect C200HX/HG/HE CV-series, and CS1-series PCs to a Controller Link Network.	W370
3G8F5-CLK11-E, 3G8F5-CLK21-E Controller Link Support Boards for ISA Bus Operation Manual	Installation, setup, and operating procedures for Controller Link Support Boards for ISA bus connections. Controller Link Support Boards are used to connect IBM PC/ATs or compatibles to a Controller Link Network.	W307
C200HW-ZW3AT2-E-V2 Controller Link Support Software Operation Manual	Installation and operating procedures for the Controller Link Support Software. The Controller Link Support Software enables manually set data links and other procedures for a Controller Link Network.	W369
3G8F7-CLK13-E, 3G8F7-CLK12-EV1, 3G8F7-CLK53-E, 3G8F7-CLK52-EV1, 3G8F7-CLK23-E, 3G8F7-CLK21-EV1 Controller Link Support Boards for PCI Bus Operation Manual	Operating procedures for Controller Link Support Boards for PCI bus connections. Controller Link Support Boards are used to connect IBM PC/ATs or compatibles to a Controller Link Network.	W383

Please read this manual and related manuals carefully and be sure you understand the information provided before attempting to install and operate a Controller Link Unit.

Precautions provides general precautions for using the Controller Link Units and related devices.

Section 1 provides basic information on Controller Link Networks, and gives the reader an overview of what Controller Link Networks can do and how best to use them.

Section 2 describes the basic procedures for using the Controller Link Unit. The settings required for each of the functions are also explained briefly. For more details, refer to the subsequent sections on individual functions.

Section 3 explains how to install a Controller Link Unit onto a CPU Backplane and how to wire the Controller Link Network.

Section 4 describes the settings required for starting communications. These basic settings are required both for data links and the message service. Carry out the settings described here before turning ON power to the Controller Link Unit.

Section 5 describes how to use data links in a Controller Link Network. Refer to Section 2 Basic Procedures for an outline of data link application.

Section 6 explains how to use the message service provided by a Controller Link Unit. It also explains the FINS commands and responses supported by Controller Link Units and those supported by CS-series, CVM1 and CV-series PLCs.

Section 7 describes the methods used to connect multiple networks through CS-series, CVM1, and CV-series PLCs. The section also describes remote programming and monitoring with Programming Devices.

Section 8 describes the duplex function for Communications Units. It also provides setting methods using the CX-Programmer and precautions for using Communications Units in duplex operation. Read this section thoroughly and be sure that you understand the contents before using Communications Units in duplex operation.

Section 9 explains details on Controller Link Network communications. Refer to this section for network communications that require accurate communications timing.

Section 10 provides information on troubleshooting errors that occur during Controller Link Unit operation, as well as daily inspection, cleaning, and other maintenance procedures.

Section 11 describes the methods used to add nodes to the Controller Link Network and change data link tables while the data links are active without turning OFF the power to the PLC in the existing network.

Appendix A provides a list of standard OMRON products related to Controller Link Networks, **Appendix B** provides easy reference to the CPU Unit memory areas related to Controller Link Networks, **Appendix C** provides information on CS-series Optical Bus Controller Link Units (production to be discontinued), and **Appendix D** provides information on handling Optical Fiber Cables.



WARNING Failure to read and understand the information provided in this manual may result in personal injury or death, damage to the product, or product failure. Please read each section in its entirety and be sure you understand the information provided in the section and related sections before attempting any of the procedures or operations given.

Read and Understand this Manual

Please read and understand this manual before using the product. Please consult your OMRON representative if you have any questions or comments.

Warranty and Limitations of Liability

WARRANTY

OMRON's exclusive warranty is that the products are free from defects in materials and workmanship for a period of one year (or other period if specified) from date of sale by OMRON.

OMRON MAKES NO WARRANTY OR REPRESENTATION, EXPRESS OR IMPLIED, REGARDING NON-INFRINGEMENT, MERCHANTABILITY, OR FITNESS FOR PARTICULAR PURPOSE OF THE PRODUCTS. ANY BUYER OR USER ACKNOWLEDGES THAT THE BUYER OR USER ALONE HAS DETERMINED THAT THE PRODUCTS WILL SUITABLY MEET THE REQUIREMENTS OF THEIR INTENDED USE. OMRON DISCLAIMS ALL OTHER WARRANTIES, EXPRESS OR IMPLIED.

LIMITATIONS OF LIABILITY

OMRON SHALL NOT BE RESPONSIBLE FOR SPECIAL, INDIRECT, OR CONSEQUENTIAL DAMAGES, LOSS OF PROFITS OR COMMERCIAL LOSS IN ANY WAY CONNECTED WITH THE PRODUCTS, WHETHER SUCH CLAIM IS BASED ON CONTRACT, WARRANTY, NEGLIGENCE, OR STRICT LIABILITY.

In no event shall the responsibility of OMRON for any act exceed the individual price of the product on which liability is asserted.

IN NO EVENT SHALL OMRON BE RESPONSIBLE FOR WARRANTY, REPAIR, OR OTHER CLAIMS REGARDING THE PRODUCTS UNLESS OMRON'S ANALYSIS CONFIRMS THAT THE PRODUCTS WERE PROPERLY HANDLED, STORED, INSTALLED, AND MAINTAINED AND NOT SUBJECT TO CONTAMINATION, ABUSE, MISUSE, OR INAPPROPRIATE MODIFICATION OR REPAIR.

Application Considerations

SUITABILITY FOR USE

OMRON shall not be responsible for conformity with any standards, codes, or regulations that apply to the combination of products in the customer's application or use of the products.

At the customer's request, OMRON will provide applicable third party certification documents identifying ratings and limitations of use that apply to the products. This information by itself is not sufficient for a complete determination of the suitability of the products in combination with the end product, machine, system, or other application or use.

The following are some examples of applications for which particular attention must be given. This is not intended to be an exhaustive list of all possible uses of the products, nor is it intended to imply that the uses listed may be suitable for the products:

- Outdoor use, uses involving potential chemical contamination or electrical interference, or conditions or uses not described in this manual.
- Nuclear energy control systems, combustion systems, railroad systems, aviation systems, medical equipment, amusement machines, vehicles, safety equipment, and installations subject to separate industry or government regulations.
- Systems, machines, and equipment that could present a risk to life or property.

Please know and observe all prohibitions of use applicable to the products.

NEVER USE THE PRODUCTS FOR AN APPLICATION INVOLVING SERIOUS RISK TO LIFE OR PROPERTY WITHOUT ENSURING THAT THE SYSTEM AS A WHOLE HAS BEEN DESIGNED TO ADDRESS THE RISKS, AND THAT THE OMRON PRODUCTS ARE PROPERLY RATED AND INSTALLED FOR THE INTENDED USE WITHIN THE OVERALL EQUIPMENT OR SYSTEM.

PROGRAMMABLE PRODUCTS

OMRON shall not be responsible for the user's programming of a programmable product, or any consequence thereof.

Disclaimers

CHANGE IN SPECIFICATIONS

Product specifications and accessories may be changed at any time based on improvements and other reasons.

It is our practice to change model numbers when published ratings or features are changed, or when significant construction changes are made. However, some specifications of the products may be changed without any notice. When in doubt, special model numbers may be assigned to fix or establish key specifications for your application on your request. Please consult with your OMRON representative at any time to confirm actual specifications of purchased products.

DIMENSIONS AND WEIGHTS

Dimensions and weights are nominal and are not to be used for manufacturing purposes, even when tolerances are shown.

PERFORMANCE DATA

Performance data given in this manual is provided as a guide for the user in determining suitability and does not constitute a warranty. It may represent the result of OMRON's test conditions, and the users must correlate it to actual application requirements. Actual performance is subject to the OMRON Warranty and Limitations of Liability.

ERRORS AND OMISSIONS

The information in this manual has been carefully checked and is believed to be accurate; however, no responsibility is assumed for clerical, typographical, or proofreading errors, or omissions.

PRECAUTIONS

This section provides general precautions for using the Controller Link Unit and related devices.

The information contained in this section is important for the safe and reliable application of the Controller Link Unit. You must read this section and understand the information contained before attempting to set up or operate a Controller Link Unit.

1	Intended Audience	xxii
2	General Precautions	xxii
3	Safety Precautions	xxii
4	Operating Environment Precautions.....	xxiii
5	Applications Precautions	xxiv
6	Conformance to EC Directives.....	xxvi

1 Intended Audience

This manual is intended for the following personnel, who must also have knowledge of electrical systems (an electrical engineer or the equivalent).

- Personnel in charge of installing FA systems.
- Personnel in charge of designing FA systems.
- Personnel in charge of managing FA systems and facilities.

2 General Precautions

The user must operate the product according to the performance specifications described in the operation manuals.

Before using the product under conditions which are not described in the manual or applying the product to nuclear control systems, railroad systems, aviation systems, vehicles, combustion systems, medical equipment, amusement machines, safety equipment, and other systems, machines, and equipment that may have a serious influence on lives and property if used improperly, consult your OMRON representative.

Make sure that the ratings and performance characteristics of the product are sufficient for the systems, machines, and equipment, and be sure to provide the systems, machines, and equipment with double safety mechanisms.

This manual provides information for programming and operating OMRON PLCs and related devices. Be sure to read this manual before attempting to use the software and keep this manual close at hand for reference during operation.

 **WARNING** It is extremely important that a PLC and all PLC Units be used for the specified purpose and under the specified conditions, especially in applications that can directly or indirectly affect human life. You must consult with your OMRON representative before applying a PLC System to the above mentioned applications.

3 Safety Precautions

 **WARNING** Do not attempt to take any Unit apart while the power is being supplied. Doing so may result in electric shock.

 **WARNING** Do not touch any of the terminals or terminal blocks while the power is being supplied. Doing so may result in electric shock.

 **WARNING** Provide safety measures in external circuits (i.e., not in the Programmable Controller), including the following items, to ensure safety in the system if an abnormality occurs due to malfunction of the PLC or another external factor affecting the PLC operation. Not doing so may result in serious accidents.

- Emergency stop circuits, interlock circuits, limit circuits, and similar safety measures must be provided in external control circuits.
- The PLC will turn OFF all outputs when its self-diagnosis function detects any error or when a severe failure alarm (FALS) instruction is executed. As a countermeasure for such errors, external safety measures must be provided to ensure safety in the system.

- The PLC outputs may remain ON or OFF due to deposition or burning of the output relays or destruction of the output transistors. As a countermeasure for such problems, external safety measures must be provided to ensure safety in the system.
- When the 24-V DC output (service power supply to the PLC) is overloaded or short-circuited, the voltage may drop and result in the outputs being turned OFF. As a countermeasure for such problems, external safety measures must be provided to ensure safety in the system.

- ⚠ **Caution** Fail-safe measures must be taken by the customer to ensure safety in the event of incorrect, missing, or abnormal signals caused by broken signal lines, momentary power interruptions, or other causes.
- ⚠ **Caution** Execute online edit only after confirming that no adverse effects will be caused by extending the cycle time. Otherwise, the input signals may not be readable.
- ⚠ **Caution** Confirm safety at the destination node before transferring a program to another node or changing contents of the I/O memory area. Doing either of these without confirming safety may result in injury.
- ⚠ **Caution** When connecting the PC to a personal computer or other peripheral device, either ground the 0-V side of the PC or do not ground the PC at all. Although some grounding methods short the 24-V side, as shown in the following diagram, never do so with the PC.

INCORRECT Grounding: Shorting the 24-V side of the Power Supply

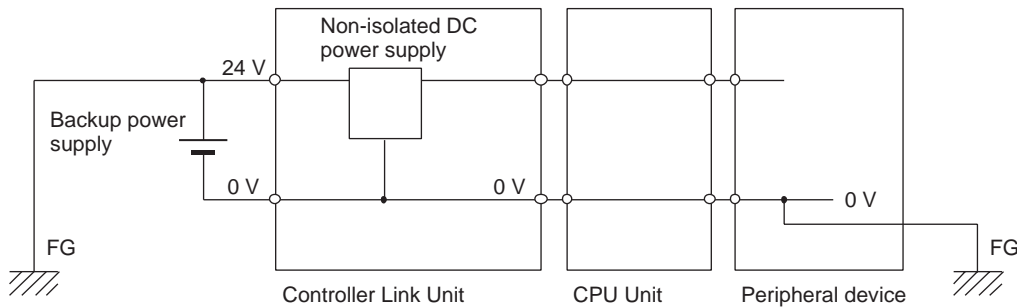

4 Operating Environment Precautions

- ⚠ **Caution** Do not operate the control system in the following locations:
 - Locations subject to direct sunlight.
 - Locations subject to temperatures or humidity outside the range specified in the specifications.
 - Locations subject to condensation as the result of severe changes in temperature.
 - Locations subject to corrosive or flammable gases.
 - Locations subject to dust (especially iron dust) or salts.
 - Locations subject to exposure to water, oil, or chemicals.

- Locations subject to shock or vibration.

 **Caution** Take appropriate and sufficient countermeasures when installing systems in the following locations:

- Locations subject to static electricity or other forms of noise.
- Locations subject to strong electromagnetic fields.
- Locations subject to possible exposure to radioactivity.
- Locations close to power supplies.

 **Caution** When using a Controller Link Unit for utility systems (electric, gas, or water), always use Optical Ring Mode with Duplex Controller Link Units, and provide necessary fail-safe systems.

 **Caution** The operating environment of the PLC System can have a large effect on the longevity and reliability of the system. Improper operating environments can lead to malfunction, failure, and other unforeseeable problems with the PLC System. Be sure that the operating environment is within the specified conditions at installation and remains within the specified conditions during the life of the system.

5 Applications Precautions

Observe the following precautions when using the Controller Link Unit.

 **WARNING** Failure to abide by the following precautions could lead to serious or possibly fatal injury. Always heed these precautions.

- Always ground the system to 100 Ω or less when installing the system to protect against electrical shock.
- Always turn OFF the power supply or the backup power supply to the PLC or the computer before attempting any of the following. (Online Unit replacement is possible for the CS1W-CLK13, CS1W-CLK12-V1, CS1W-CLK53, and CS1W-CLK52-V1.) Performing any of the following with the power supply turned ON may lead to electrical shock:
 - Installing or removing the Controller Link Unit.
 - Assembling the Units.
 - Setting DIP or rotary switches.
 - Connecting or disconnecting any cables or wiring.
 - Connecting or disconnecting any connectors.

 **Caution** Failure to abide by the following precautions could lead to faulty operation or the PLC or the system or could damage the PLC or PLC Units. Always heed these precautions.

- Fail-safe measures must be taken by the customer to ensure safety in the event of incorrect, missing, or abnormal signals caused by broken signal lines, momentary power interruptions, or other causes.
- Interlock circuits, limit circuits, and similar safety measures in external circuits (i.e., not in the Programmable Controller) must be provided by the customer.

- Always use the power supply voltages specified in the operation manuals. An incorrect voltage may result in malfunction or burning.
- Take appropriate measures to ensure that the specified power with the rated voltage and frequency is supplied. Be particularly careful in places where the power supply is unstable. An incorrect power supply may result in malfunction.
- Install external breakers and take other safety measures against short-circuiting in external wiring. Insufficient safety measures against short-circuiting may result in burning.
- Separate the Unit from equipment that generates strong high-frequency noise.
- Separate the line ground terminal (LG) from the functional ground terminal (GR) on the Power Supply Unit before performing withstand voltage tests or insulation resistance tests. Not doing so may result in burning.
- Do not attempt to disassemble, repair, or modify any Units. Any attempt to do so may result in malfunction, fire, or electric shock.
- Do not drop the Unit and do not subject it to abnormal vibration or shock to the Unit.
- Be sure that all the mounting screws, terminal screws, and cable connector screws are tightened to the torque specified in the relevant manuals. Incorrect tightening torque may result in malfunction.
- Leave the label attached to the Unit when wiring. Removing the label may result in malfunction if foreign matter enters the Unit.
- Remove the label after the completion of wiring to ensure proper heat dissipation. Leaving the label attached may result in malfunction.
- Use crimp terminals for wiring. Do not connect bare stranded wires directly to terminals. Connection of bare stranded wires may result in burning.
- Double-check all wiring and switch settings before turning ON the power supply. Incorrect wiring may result in burning.
- Wire all connections correctly.
- Mount Units only after checking terminal blocks and connectors completely.
- Be sure that the communications cable connectors and other items with locking devices are properly locked into place. Improper locking may result in malfunction.
- Use special packing box when transporting the Controller Link Unit. Handle the product carefully so that no excessive vibration or impact is applied to the product during transportation.
- Check the user program for proper execution before actually running it on the Unit. Not checking the program may result in an unexpected operation.
- Confirm that no adverse effect will occur in the system before attempting any of the following. Not doing so may result in an unexpected operation.
 - Changing the operating mode of the PLC (including the setting of the startup operating mode).
 - Force-setting/force-resetting any bit in memory.
 - Changing the present value of any word or any set value in memory.
- Inappropriate settings in data link tables or routing tables can cause unexpected system operation. Always check table settings before starting

operation, and always test the settings in trial operation before starting or stopping the data links in actual operation.

- CPU Bus Units will be automatically restarted when routing tables are transferred from a Programming Device to the CPU Unit. Resetting is required to use the new tables. Confirm that restarting the CPU Bus Units will not adversely affect system operation before transferring routing tables.
- Observe the following precautions when wiring the communications cable or backup power supply cables.
 - Separate the cables from the power lines or high-tension lines.
 - Do not bend the cables.
 - Do not pull on the cables.
 - Do not place heavy objects on top of the cables.
 - Route cables inside conduits.
- Before touching the Unit, be sure to first touch a grounded metallic object in order to discharge any static build-up.

6 Conformance to EC Directives

The Controller Link Units conform to EMC Directives as follows:

EMC Directives

OMRON devices that comply with EC Directives also conform to the related EMC standards so that they can be more easily built into other devices or the overall machine. The actual products have been checked for conformity to EMC standards (see the following note). Whether the products conform to the standards in the system used by the customer, however, must be checked by the customer.

EMC-related performance of the OMRON devices that comply with EC Directives will vary depending on the configuration, wiring, and other conditions of the equipment or control panel on which the OMRON devices are installed. The customer must, therefore, perform the final check to confirm that devices and the overall machine conform to EMC standards.

Note Applicable EMC (Electro-Magnetic Compatibility) standards are as follows:

EMS (Electro-Magnetic Susceptibility): EN61131-2 for CVM1 and CV Series
EN61000-6-2 for CS Series

EMI (Electro-Magnetic Interference): EN61000-6-4
(Radiated emission: 10-m regulations)

The Controller Link Units that comply with EC Directives (CVM1-CLK12, CVM1-CLK52, CS1W-CLK11, CS1W-CLK13, CS1W-CLK12-V1, CS1W-CLK53, and CS1W-CLK52-V1) must be installed as follows:

- 1,2,3...**
1. The Controller Link Units are designed for installation inside control panels. All Controller Link Units must be installed within control panels. Use the following or equivalent control panels: CVM1-CLK12/52: SA20-614 by NITTO Electric Words, Ltd., CS1W-CLK11/13/12-V1/53/52-V1: SA20-712 by NITTO Electric Words, Ltd.
 2. Use reinforced insulation or double insulation for the DC power supplies used for the communications power supply and I/O power supplies.
 3. The Controller Link Units that comply with EC Directives also conform to the Common Emission Standard (EN61000-6-4). Radiated emission characteristics (10-m regulations) may vary depending on the configuration of

the control panel used, other devices connected to the control panel, wiring, and other conditions. You must therefore confirm that the overall machine or equipment complies with EC Directives.

4. The Controller Link Units conform to the Emission Standard (EN61000-6-2) for EMS but, depending on the backup power supply used, they may not conform to the standard for immunity to surges (IEC61000-4-5). In order to ensure conformance, either use an OMRON S82K-series power supply, which is the recommended backup power supply, or take surge countermeasures at the primary side.

SECTION 1

Features and System Configuration

This section provides basic information on Controller Link Networks, and gives the reader an overview of what Controller Link Networks can do and how best to use them.

1-1	Overview	2
1-1-1	What Is the Controller Link?	2
1-1-2	Features	7
1-2	Specifications and Configurations	13
1-2-1	System Configuration	13
1-2-2	Models	15
1-2-3	General Specifications	16
1-2-4	Communications Specifications	16
1-2-5	Controller Link Unit Models and PLCs	17
1-2-6	Devices Required for Connection	21
1-2-7	Programming Devices	25
1-2-8	Backup Power Supply	29
1-3	Selecting Communications Functions	30
1-4	Basic Procedures	30
1-5	Application Precautions	31

1-1 Overview

1-1-1 What Is the Controller Link?

The Controller Link is an FA network that can send and receive large data packets flexibly and easily among the OMRON C200HX/HG/HE Programmable Controllers (PLCs), CS-series PLCs, CVM1 PLCs, CV-series PLCs, and IBM PC/AT or compatible computers.

The Controller Link supports data links that enable data sharing and a message service that enables sending and receiving data when required. Data link areas can be freely set to create a flexible data link system and effectively use data areas.

High-volume data transmissions at high speed enable construction of a wide range of networks, from low-level systems to high.

A Controller Link Network can be connected by either shielded twisted-pair cable or fiber-optic cable. For details on networks using twisted-pair cable (i.e., Wired Systems), refer to the *Controller Link Unit Operation Manual* (W309).

The functions of a Controller Link Network are outlined below.

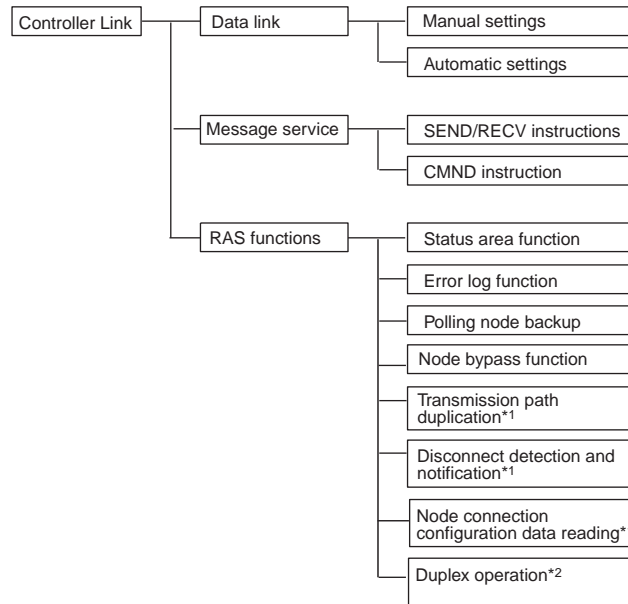

*1: In token-ring mode only.

*2: CS1W-CLK13, CS1W-CLK12-V1, CS1W-CLK53, and CS1W-CLK52-V1 only.

Wired System (Twisted-pair Cable)

Wired Systems are supported by CS-series, C200HX/HG/HE, CVM1, and CV-series PLCs.

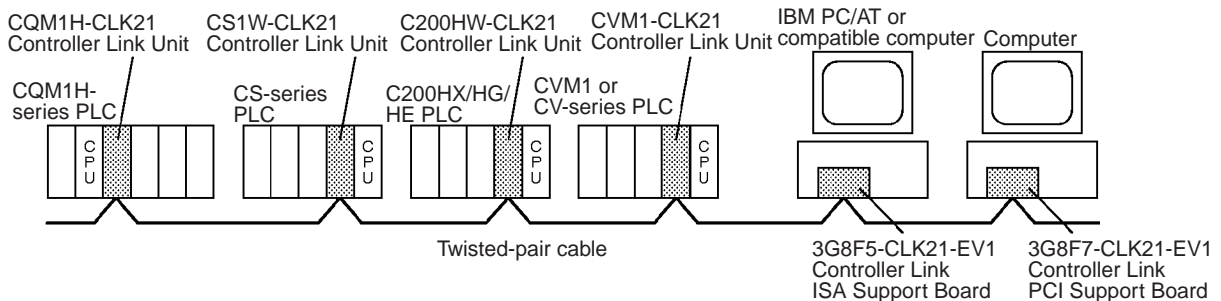

Optical Bus or Optical Ring System (H-PCF Cable)

Optical Systems are supported by CS-series, CVM1, and CV-series PLCs.

Token-ring Mode

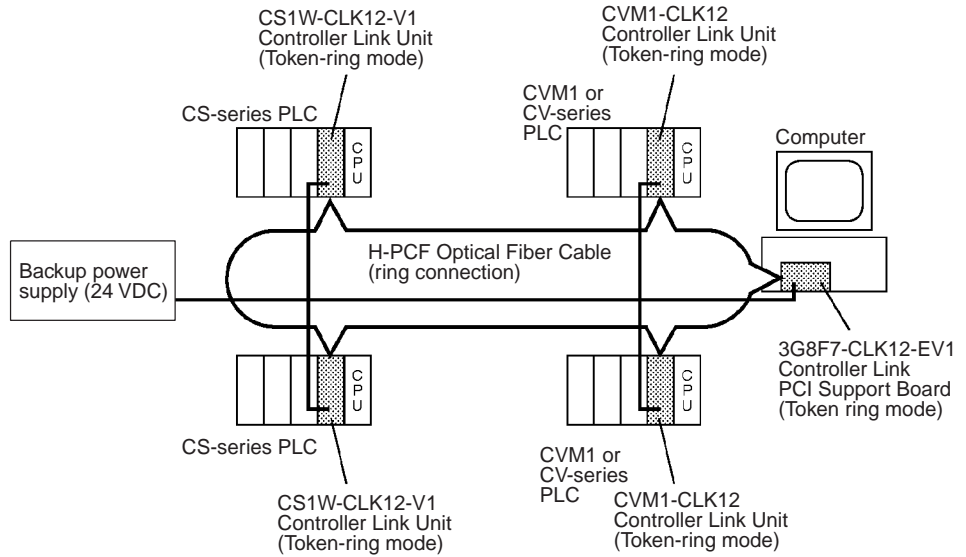

Token-ring Mode in a CS1D System with Duplex Controller Link Units

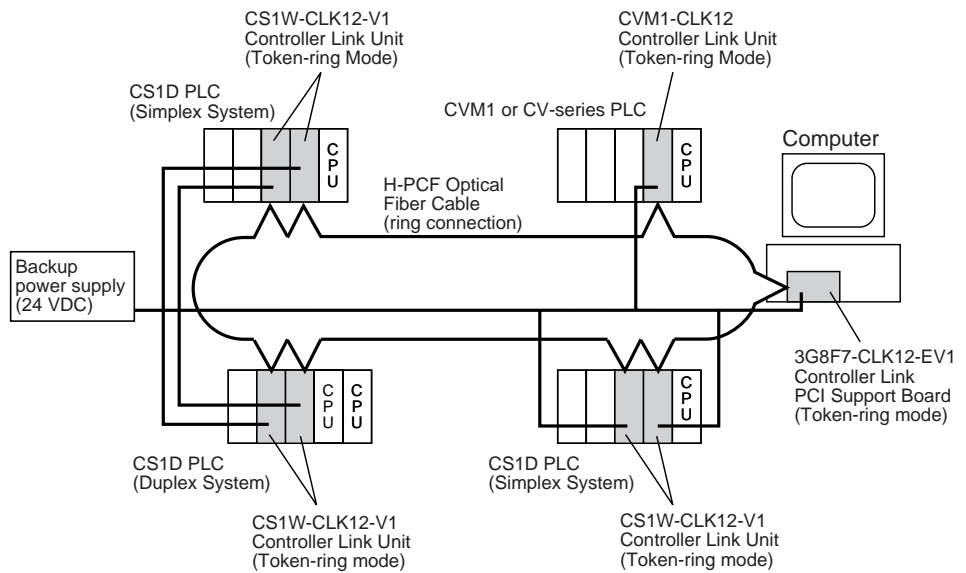

Token-bus Mode

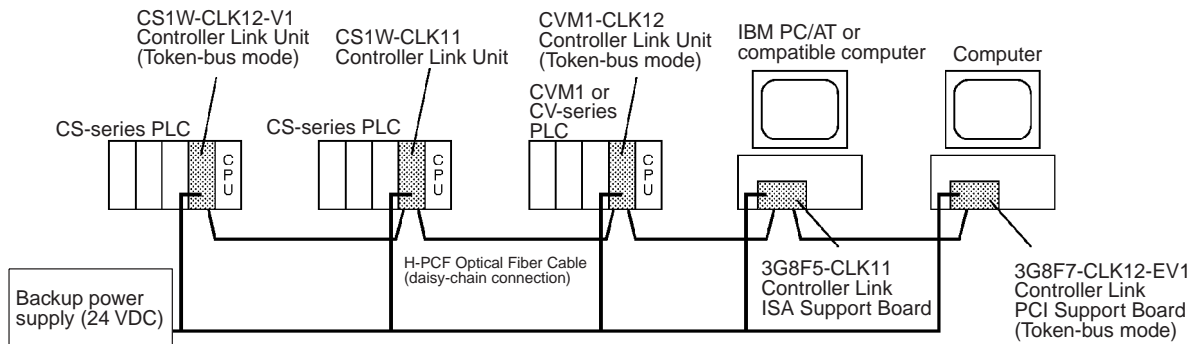

Optical Bus or Optical Ring System (GI Cable)

Optical Systems are supported by CS-series, CVM1, and CV-series PLCs.

Token-ring Mode

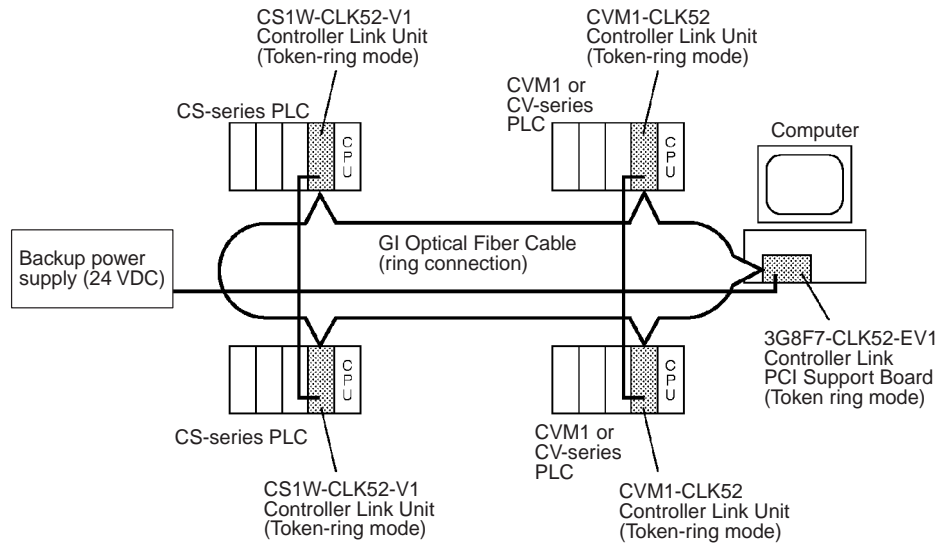

Token-ring Mode in a CS1D System with Duplex Controller Link Units

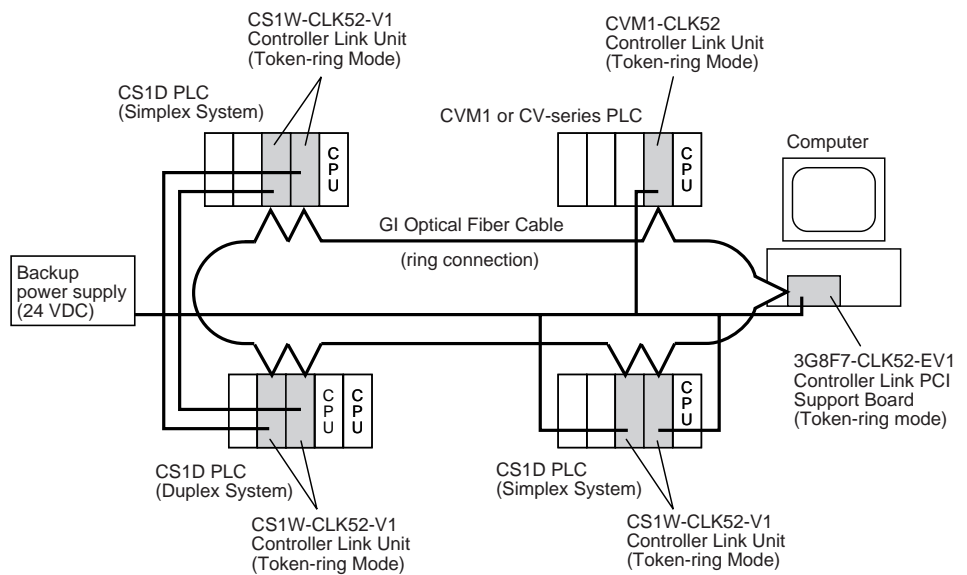

Token-bus Mode

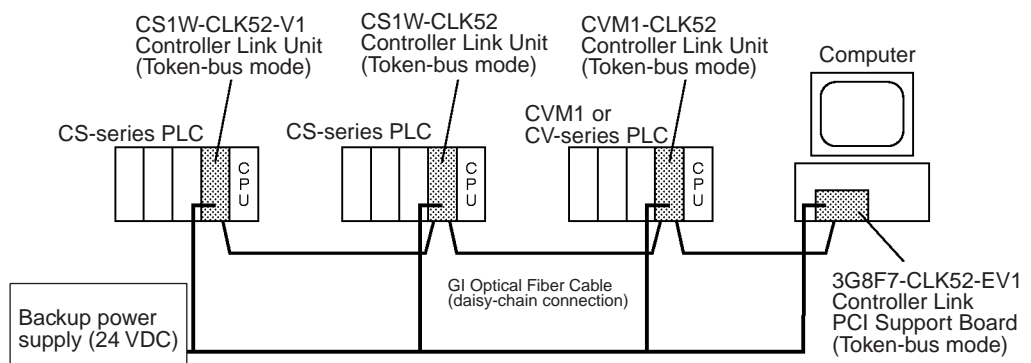

Data Links

Data links allow the constant sharing of data in predetermined data areas between nodes, between PLCs, or between a PLC and an IBM PC/AT or compatible computer on the network. Data links do not require the use of communications programs on the PLC (CPU Unit) or IBM PC/AT or compatible computer. Data written in the send area of the local node will be automatically sent to the receive area of other nodes.

The I/O area (CIO area), link area (LR area), data memory area (DM area), and extended data memory area (EM area) can be freely set in the send or receive area. (The area used for sending or receiving data using the data link function is called “data link area.”)

The data link area can be set automatically or manually.

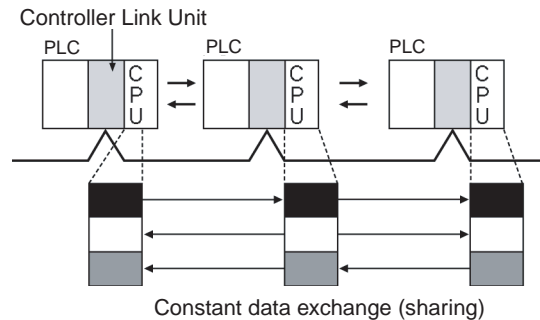

Automatic Setting

Used for simple data link processing. Data link can be performed by simply setting parameters in the DM area of the PLC.

Send data size per node is the same for all nodes. All nodes participating in the data link share the same data.

Manual Setting

Used for flexible data link processing depending on each system.

Using the Controller Link Support Software, individual data link tables can be set for each node and the data link area can be freely allocated for each node. Send data size per node can be freely set. It is also possible to set nodes for only send or receive data. With the Controller Link Unit, the data link can be set to receive only a part of the data link area of other nodes.

Message Service

This function controls data transmission with particular nodes, reading or writing of status data, changing of operation modes, etc., by executing communications instructions on a program. The communications instructions include SEND/RCV instructions for data transmission and CMND instructions for issuing various commands.

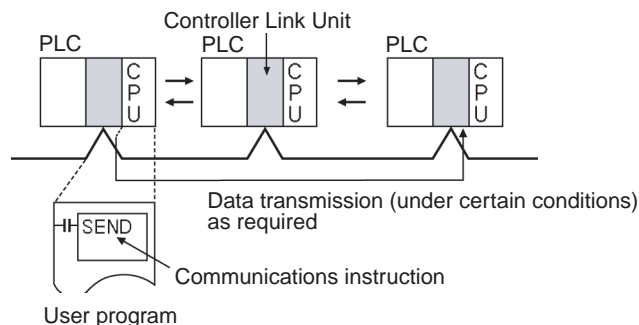

SEND/RCV

The SEND or RCV instruction sends or receives data in an area of a particular node.

The SEND instruction sends data from an area of the local node and writes to an area in the designated node.

The RECV instruction requests the designated node to send area data and writes the data to the local node.

CMND

The CMND instruction issues a command to read or write data of other nodes, control, or read error logs. With the Controller Link Unit, OMRON's command protocol called "FINS commands" is used.

RAS

RAS performs real-time monitoring of the network status. If an error occurs in the network, RAS records and displays the time and contents of the error.

Status Area

Data Link Status Area

When the data link function is used, the data link status is reflected in the data link status area of the PLC.

Network Status Area Other than the Data Link

The network status such as the state of node participation is reflected in the status area of the PLC.

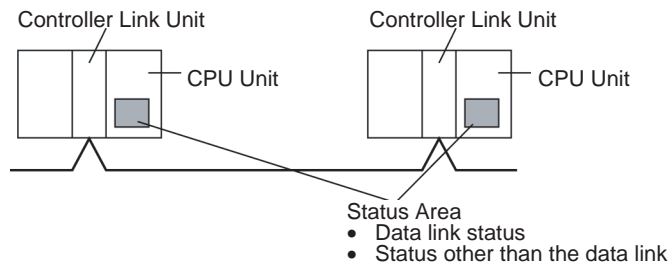

Error Log

The error log function records contents (codes) and times of errors that occur in the network into the RAM or EEPROM, up to the maximum of 64 errors (See note.).

The recorded errors can be read using the Controller Link Support Software or the message service function.

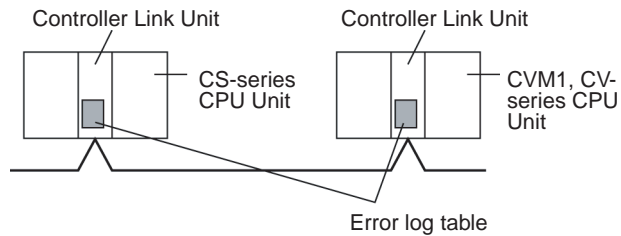

Note The number of error log records depends on the model. For details, refer to 10-3 Error Log.

Node Bypass

Data communications can be continued by bypassing the node, even when a node in the communications line malfunctions or the PLC or IBM PC/AT or compatible computer power supply is turned OFF. This prevents the whole network system from being affected by a node malfunction or power interruption.

To use the bypass node function, backup power must be supplied to the Controller Link Unit/Support Board.

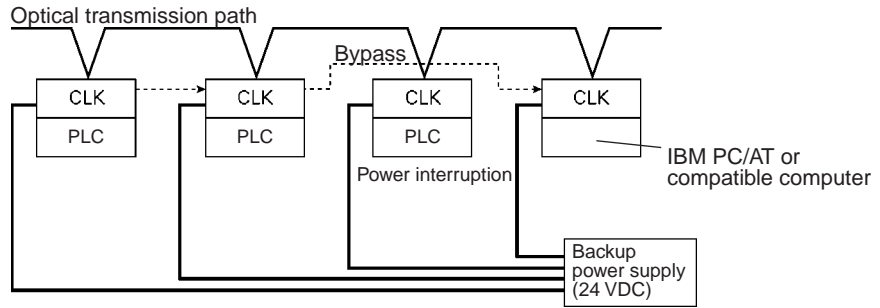

Transmission Path Duplication

In the token-ring mode in an Optical Ring System (H-PCF cable or GI cable), data transmission will be unaffected even by a cable or connector break at one location in the ring connection. With the fiber-optic cable wired in a ring shape, a break at one point will simply cause the transmission to be routed in the other path.

Disconnect Detection and Notification

Even with transmission path duplication, the network will be broken if disconnections occur in two or more places. In the token-ring mode in an Optical Ring System (H-PCF cable or GI cable), the location of a disconnection can be detected and can be identified by means of the status display for all nodes. This function can be used to prevent system crashes in advance, by performing maintenance when a disconnection occurs at one place.

Node Connection Configuration Data Reading

In the token-ring mode in an Optical Ring System (H-PCF cable or GI cable), connection data can be read for all of the nodes configured in the network. The information that can be read includes the order in which the nodes are connected and which of two optical connectors is connected to which node. Special support software (Controller Link Support Software, Ver. 2.00 or later) is required in order to read the node connection configuration data.

Duplex Units

By mounting the CS1W-CLK13, CS1W-CLK12-V1, CS1W-CLK53, or CS1W-CLK52-V1 to a CS1D PLC, Controller Link Units can be used in duplex operation. If an error occurs at the active Controller Link Unit, the standby Controller Link Unit will take over operation, and communications operation will continue. Also, Controller Link Units with errors can be replaced without turning OFF the power (i.e., online replacement).

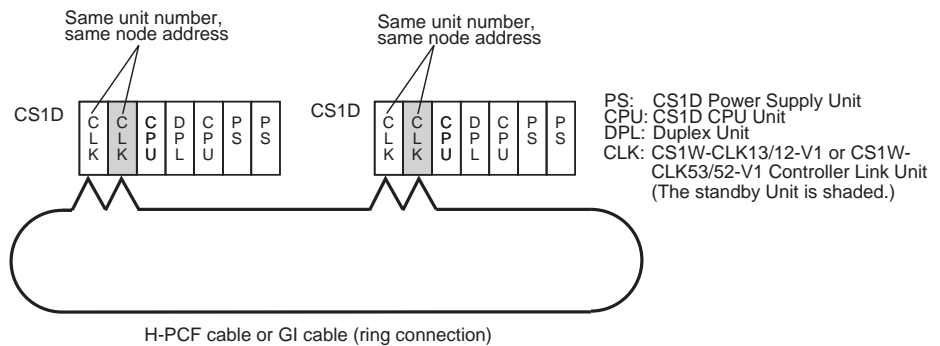

1-1-2 Features

The Controller Link Network has the following features to meet the various requirements of FA sites.

Data Links

Flexible and efficient data links can be created for large capacities of data as listed below.

Number of send words per node

CS1W-CLK13 and CS1W-CLK53: 4,000 words max.

All other Units: 1,000 words max.

Number of send and receive words per node

CS-series PLCs (Unit Ver. 1.2 or later): 20,000 words max.

Pre-Ver. 1.2: 12,000 words max.

CVM1, CV-series PLCs: 8,000 words max.

Personal computer with PCI Board: 62,000 words max.

Data links can be automatically set, or they can be set by the user to freely change the sizes of the data areas used. A data link can also be created so that one node receives only part of the data sent from another node. This function enables users to receive only the required data, thereby increasing data link efficiency.

Message Service

The message service can send and receive up to 2,012 bytes of data (including the FINS header), allowing high volumes of data to be sent and received without having to split it up.

Twisted-pair Cable or Optical Fiber Cable Connection

The Controller Link Units can be connected to the network using either shielded twisted-pair cable, H-PCF fiber-optic cable, or GI fiber-optic cable. Select the system that suits your application.

Features of Optical Fiber Cable

Optical Fiber Cable has superior noise resistance, so this system can provide highly reliable communications even in very noisy conditions. The fiber-optic cable allows long-distance and large-scale networks.

With H-PCF fiber-optic cable, the communications distance can be up to 20 km in total (1 km max. between nodes). With GI fiber-optic cable, the communications distance can be up to 30 km in total (2 km max. between nodes).

Once the Optical Fiber Cable has been fitted with special connectors, the cables can be easily connected or disconnected.

Features of Twisted-pair Cable

Twisted-pair cable is easy to connect and maintain. The cable can be processed much more easily than coaxial or fiber-optic cable, thereby reducing the cost of tools and assembly time.

Connections are made to a terminal block on the Controller Link Unit and to a special connector on the Controller Link Support Board for easy system assembly and modification.

The network is equipped with the required terminating resistance built into the Units allowing the terminating resistance to be easily set at both ends of the network using a simple switch.

Compatibility with Different Node Configurations

The following Controller Link Units and Controller Link Boards are available for communications between different models.

Optical Ring System (H-PCF Cable)

- Controller Link Units for CS-series Programmable Controllers
- Controller Link Units for CVM1 and CV-series Programmable Controllers
- Controller Link Boards for personal computers with PCI bus

Optical Ring System (GI Cable)

- Controller Link Units for CS-series Programmable Controllers
- Controller Link Units for CVM1 and CV-series Programmable Controllers
- Controller Link Boards for personal computers with PCI bus

Optical Bus System

- Controller Link Units for CS-series Programmable Controllers
- Controller Link Boards for personal computers with ISA bus

Flexible Inter-network Connections

The Controller Link Network can connect to other networks (Ethernet, SYSMAC NET, SYSMAC LINK, and another Controller Link network) via CVM1, CV-series, or CS-series PLCs. By installing a Communications Unit for the Ethernet, SYSMAC NET or SYSMAC LINK on the same CS-series or CV series-PLC as a Controller Link Unit, a message service can be created with nodes in interconnected networks through the CVM1 or CV-series PLC. Up to eight network levels are possible.

Note CS-series PLC cannot be installed on SYSMAC NET and SYSMAC LINK networks.

The programming and monitoring of other PLCs on the network can be conducted from Programming Devices connected to the PLC's CPU Unit. Inter-network connections are possible in this case also and can cover up to eight network levels.

Use a CS-series CPU Unit with unit version 2.0 or later and CX-Programmer Ver. 4.0 or later to enable internetwork connections for up to eight networks.

Improved Error Handling

An error log enables quick handling of errors by recording the time the error occurred and error details. The current Controller Link Unit and Support Board status are also available, as are the data link and network status.

When an error occurs in the polling node that controls the Controller Link Network, another node automatically becomes the polling node. This prevents an error at a single node from influencing other nodes on the network, achieving a highly reliable system.

In the token-ring mode in an Optical Ring System (H-PCF or GI cable), data transmission will be unaffected even by a cable or connector break at one location in the ring connection. Also, with the disconnect detection and notification function, the location of a disconnection can be checked, making it possible to prevent system crashes in advance by facilitating inspection and maintenance.

Greater Reliability with Duplex Communications Units System

By mounting the CS1W-CLK13, CS1W-CLK12-V1, CS1W-CLK53, or CS1W-CLK52-V1 to a CS1D PLC (see note 1), Controller Link Units can be used in duplex operation. The settings for duplex operation can be performed easily.

If an error occurs at the active Controller Link Unit, the standby Controller Link Unit will take over operation, and communications operation will continue.

Note 1. Controller Link Units can be used in duplex operation only in CS1D Systems with CS1D CPU Units mounted to Duplex Backplanes. (Duplex operation is possible for either duplex or simplex systems.) For details on the CS1D, refer to the *CS-series Duplex System Operation Manual* (W405).

Duplex settings for Controller Link Units can be performed with CX-Programmer Ver. 3.0 or later.

2. Active/standby switchover will take place when the following errors occur at the active Controller Link Unit.
 - EEPROM error
 - Error in the communications controller's transmitter
 - Hardware error in the communications controller
 - Watchdog timer error

Using token-ring mode allows transmission path duplication. This means that communications are not affected if there is a cable or connector disconnection at one point in the network. Also, the location of a disconnection can be identified by the disconnect detection and notification function (supported by existing models), allowing maintenance to be performed quickly and system failures to be prevented.

Used in combination with token-ring mode, Duplex Communications Units allow the creation of communications systems with greater reliability. It is possible to use Duplex Communications Units in token-bus mode, but when an active/standby switchover occurs because of an error in the active Controller Link Unit, or when Units are replaced online, because the system does not have duplex transmission paths, the network is split into two. Therefore, use Controller Link Units in token-ring mode.

When using the CS1D System in token-ring mode, if an error occurs at a Communications Unit (Controller Link Unit), the online replacement function (see note) allows the Unit to be replaced without stopping system operation or communications for the whole network. In particular, if the Unit is used in duplex operation, the other Unit switches to active mode and quickly joins the network, minimizing the influence on communications.

Note The online replacement function is a function that allows Units in CS1D Systems to be replaced without turning OFF the power for the whole PLC. It can be executed only from a Programming Console.

Two Controller Link Units that are used in duplex operation are treated as just one node in the Controller Link Network and can be used in the same way as pre-version 1 models (i.e., without “-V1” at the end of the model number). The operating status of the active Controller Link Unit is constantly stored in the standby Controller Link Unit and so operation continues smoothly if there is an active/standby switchover between the Units.

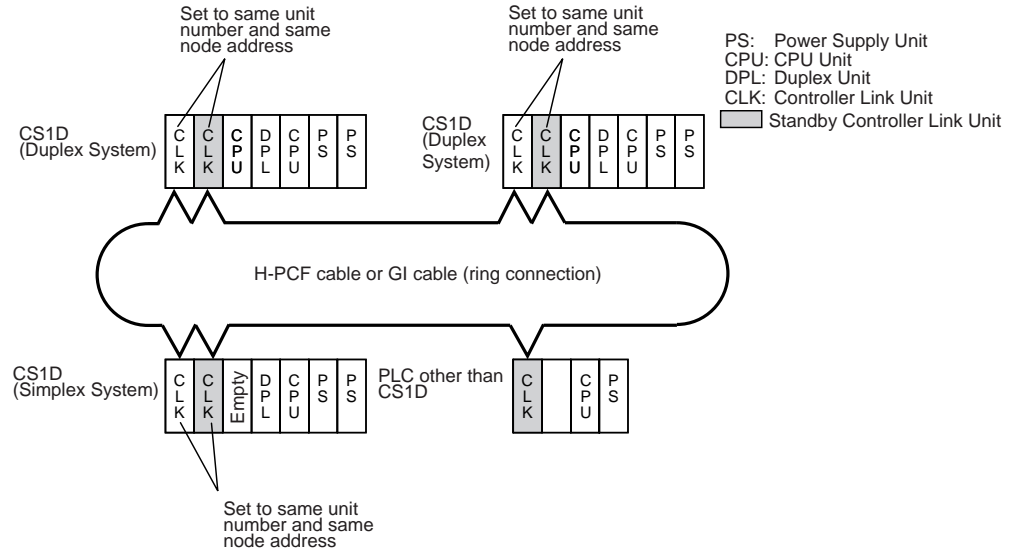

Data Link Settings and Changes Made Easy

Automatic Data Link Creation with 1:N Allocations

Applicable Models:

- CS1W-CLK12-V1 and CS1W-CLK52-V1 Controller Link Units with lot numbers 0306□□_□□□□ or later (manufactured after May, 2003).
- CS1W-CLK13/53
- 3G8F7-CLK13/12-V1/53/52-V1

Overview

It is possible to perform unequal 1:N allocations of data between nodes with automatic data link creation. This makes it easy to perform data links that formerly required the user to manually edit data link parameters.

The following four automatic data link creation patterns can be used:

- Equality layout (the previous pattern)
- 1:N allocation, common type
- 1:N allocation, 1 to 1 type
- 1:N allocation, chain type

Method

Allocation addresses and sizes are all specified using the Automatic Data Link Creation Parameters (D30000 × Unit No. + 12 to 20) in the DM parameters area. These values can be set using the CX-Net in CX-Programmer version 3.2 or later.

Objective

This function is effective in applications that collect data from slave PLCs into a master PLC.

Manually Created Data Link Table Changes during Data Link Operation**Restrictions**

Automatic data link creation with 1:N allocations cannot be performed if version-1 models and pre-version-1 models are used together in the same network.

Applicable Models:

- CS1W-CLK12-V1 and CS1W-CLK52-V1 Controller Link Units with lot numbers 0306□□_□□□□ or later (manufactured after May, 2003).
- CS1W-CLK13/53
- 3G8F7-CLK13/12-V1/53/52-V1

Overview

It is possible to modify a manually created data link table while data links are running.

Note This is possible only with manually created data link tables. Any attempt to change automatically created data link tables when data links are running will fail and an error message will be displayed saying that the tables cannot be edited during data link operation.

Method

This function can be set using the CX-Net in CX-Programmer version 3.2 or later.

Objectives

- In systems that operate non-stop and cannot be turned OFF, this function makes it possible to change data link tables to accommodate the addition of new nodes and to transfer data link tables without having to stop manually set data link communications.
- If this function is combined with the use of token-ring mode to add network nodes, it becomes possible to construct systems of greater flexibility.

Operation

When a node is being modified online, this function temporarily stops refreshing of data link data until modifications have been completed.

Nodes will participate in data links after changes to the data link table have been completed.

1-2 Specifications and Configurations

1-2-1 System Configuration

A single Controller Link Network is configured as shown in the following diagram.

Optical Bus or Optical Ring System (H-PCF Cable)

Token-ring Mode

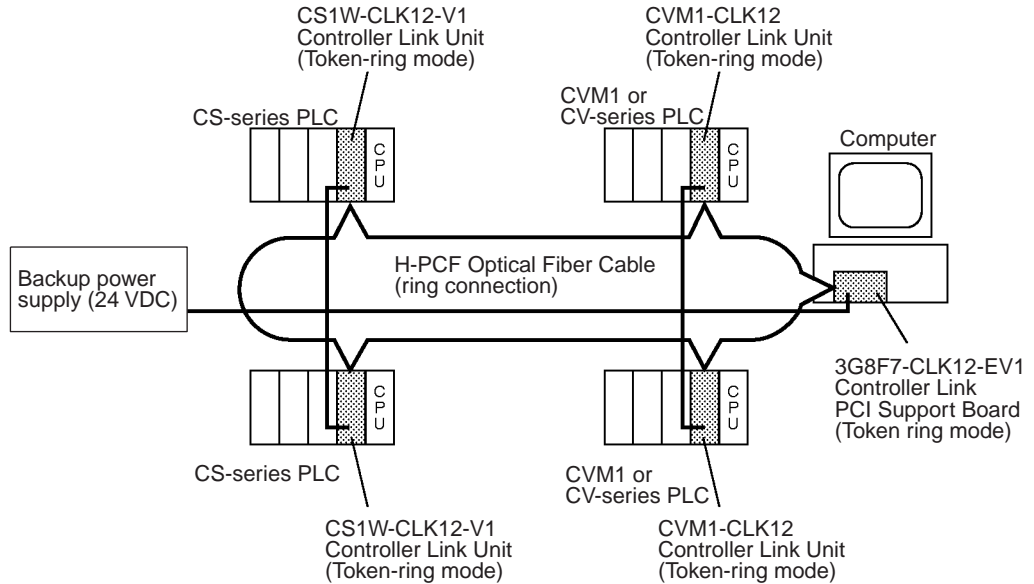

Token-ring Mode in CS1D System with Duplex Controller Link Units

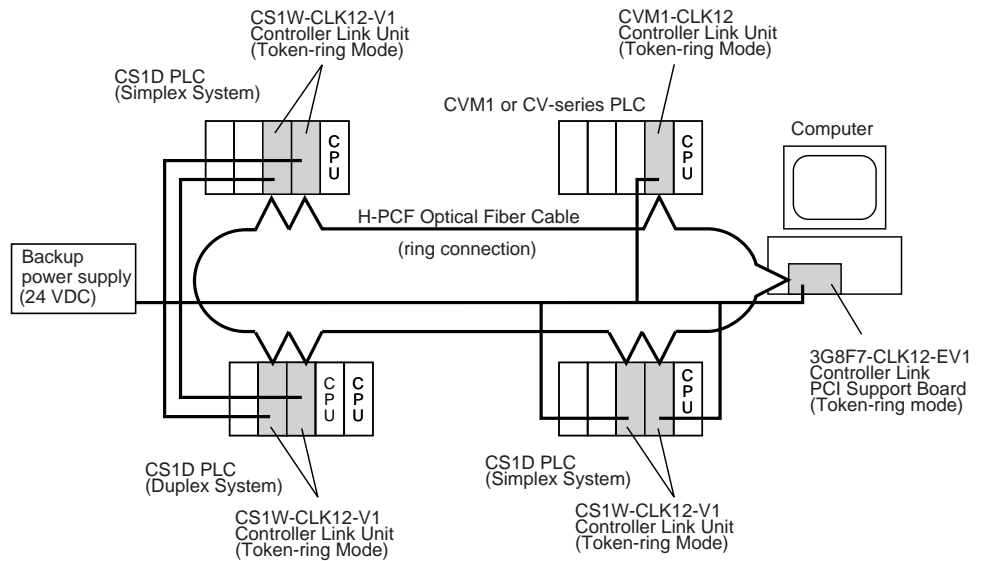

Units can be used in duplex operation only when the new version-1 Controller Link Units are mounted on a CS1D PLC. Either a CS1D Duplex System or CS1D Simplex System allows duplex operation of Communications Units.

Controller Link Networks can include both nodes with Units in duplex operation (new models) and nodes without Units used in duplex operation (new models and/or existing models) as well as CVM1 and CV-series Controller Link Units.

Token-bus Mode

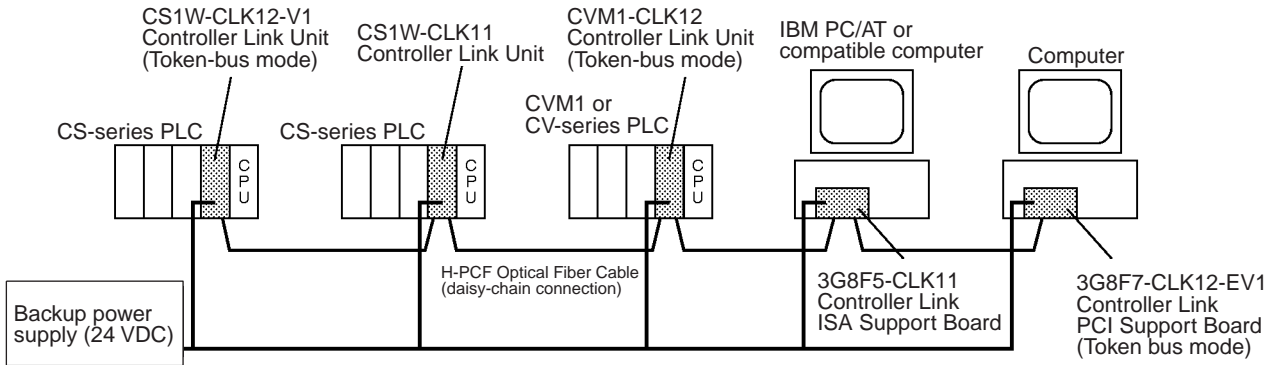

Optical Bus or Optical Ring System (GI Cable)

Token-ring Mode

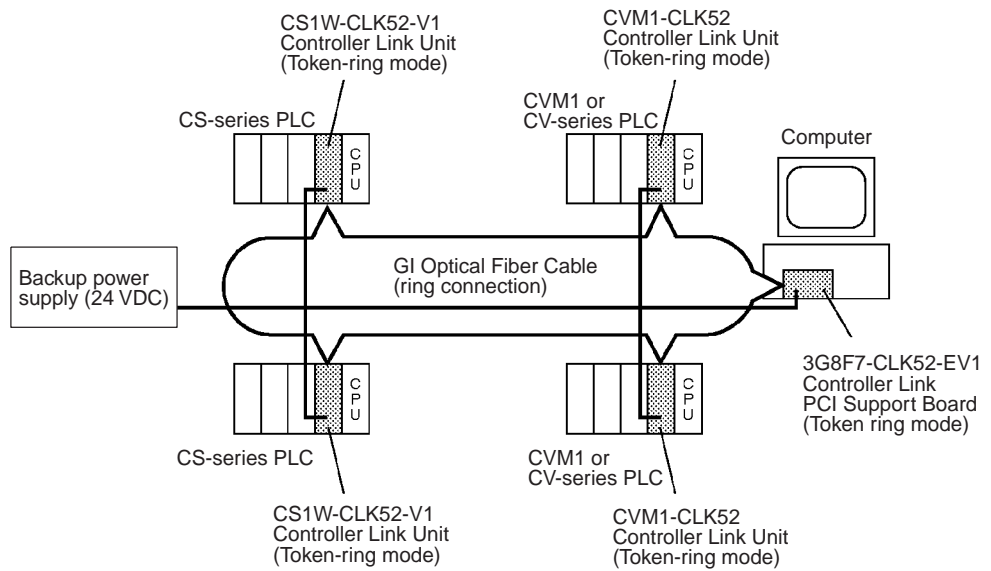

Token-ring Mode in a CS1D System with Duplex Controller Link Units

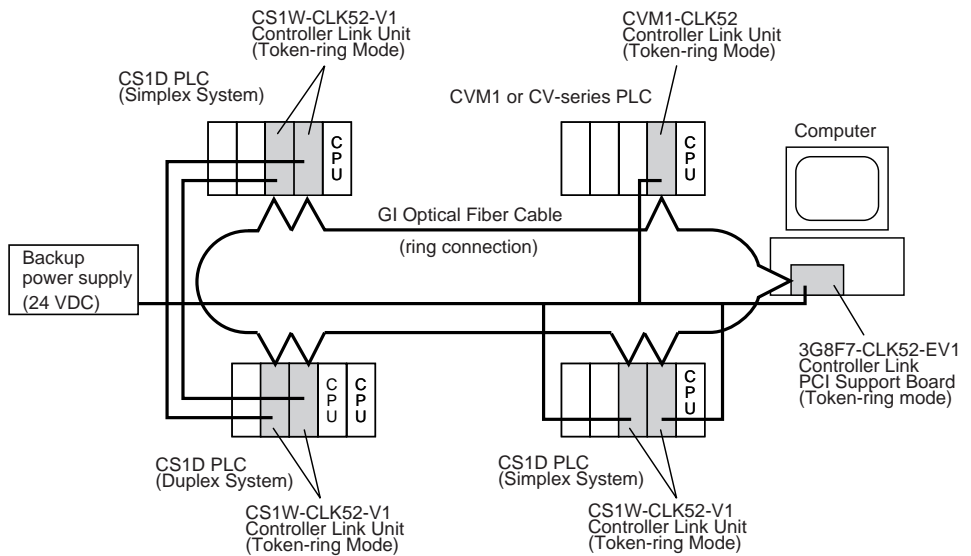

Units can be used in duplex operation only when the new version-1 Controller Link Units are mounted on a CS1D PLC. Either a CS1D Duplex System or a CS1D Simplex System allows duplex operation of Units.

Controller Link Networks can include both nodes with Units used in duplex operation (new models) and nodes without Units used in duplex operation (new models and/or existing models) as well as CVM1 and CV-series Controller Link Units.

Token-bus Mode

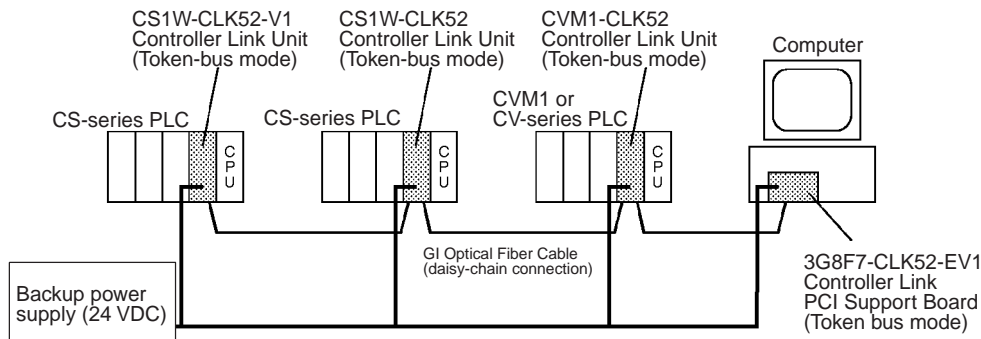

1-2-2 Models

Type	Name	Model number	Transmission format	
			Token ring	Token bus
Optical Ring (H-PCF cable)	Controller Link Unit for CS-series PLCs	CS1W-CLK13 CS1W-CLK12-V1 (See note 2.)	Selectable (See note 2.)	
	Controller Link Unit for CVM1 or CV-series PLCs	CVM1-CLK12	Selectable (See note 2.)	
	Controller Link PCI Support Board	3G8F7-CLK13 3G8F7-CLK12-EV1	Selectable (See note 2.)	
Optical Ring (GI cable)	Controller Link Unit for CS-series PLCs	CS1W-CLK53 CS1W-CLK52-V1 (See note 2.)	Selectable (See note 2.)	
	Controller Link Unit for CVM1 or CV-series PLCs	CVM1-CLK52	Selectable (See note 2.)	
	Controller Link PCI Support Board	3G8F7-CLK53 3G8F7-CLK52-EV1	Selectable (See note 2.)	
Optical Bus	Controller Link Unit for CS-series PLCs	CS1W-CLK11 (See note 3.)	No	Yes

- Note**
1. The CS1W-CLK12-V1 and CS1W-CLK52-V1 are completely compatible upgrades of the CS1W-CLK12 and CS1W-CLK52. The new models support duplex operation. For details, refer to *8-4 Precautions for Duplex Systems*.
 2. The transmission format is selected by means of software switches in the DM Area parameters.
 3. For details on the CS1W-CLK11 Optical Bus Controller Link Unit, refer to *Appendix C CS-series Optical Bus Controller Link Units*.
 4. The CS1W-CLK13 and the CS1W-CLK53 are upwardly compatible with the CS1W-CLK12-V1 and CS1W-CLK52-V1, respectively. For details, refer to *Version Upgrade Functions for V1 or Higher Models* on page 289.

1-2-3 General Specifications

General specifications are the same for the CS-series, CVM1, and CV-series PLCs.

1-2-4 Communications Specifications

Optical Ring System

Items	Specifications	
Type	Optical Ring (H-PCF cable)	Optical Ring (GI cable)
Communications method	N:N token-ring method (token-ring mode) N:N token-bus method (token-bus mode)	
Code	Manchester code	
Modulation	Baseband code	
Synchronization	Flag synchronization (conforms to HDLC frames)	
Transmission path format	Ring method (token-ring mode) Daisy-chain method (token-bus mode)	
Transmission speed	2 Mbps	
Maximum transmission distance	20 km	30 km
Maximum distance between nodes	Crimp cut: 800 m Adhesive: 1 km (See note 1.)	62.5/124 μm : 2 km 50/125 μm : 1 km
Medium	H-PCF cable (optical two-core cable)	GI cable (optical two-core cable, 62.5/125 μm or 50/125 μm)
Node connection method	Connected via a special (full-lock connector) connector. (A half-lock connector can also be used.)	Connected via ST connectors.
Maximum number of nodes	62 nodes (See notes 2 and 3.)	
Applicable Programming Devices	Controller Link Support Software (Ver. 2.00 or later), CX-Net in CX-Programmer (see note 3), and Programming Console.	
Communications functions	Data links and message service	
Number of data link words	Send words per node: 4,000 words max. (CS1W-CLK13 and CS1W-CLK53) 1,000 words max. (All other Units) Number of send/receive words per node: 8,000 words max. (CVM1/CV) 12,000 words max. (CS Pre-Ver. 1.2) 20,000 words max. (CS unit Ver. 1.2 or later) Total number of send words per network: 62,000 words max. (See note 2.)	
Data link areas	Bit areas (CIO, AR, LR), DM, EM (See note 4.)	
Message length	2,012 bytes max. (including the header)	
RAS functions	Polling node backup function Self-diagnosis function (hardware checking at startup) Echoback test and broadcast test (using the FINS command) Watchdog timer Error log function Node bypass function Transmission path duplication (For ring method in token-ring mode only.) Disconnect detection and notification (Token-ring mode only.) Node connection configuration data reading (For ring method in token-ring mode only.) Duplex operation of Communications Units (See note 5.)	
Error control	Manchester code check CRC check (CCITT $X^{16} + X^{12} + X^5 + 1$)	

- Note**
1. The maximum distance between nodes depends on the connector and cable processing methods.
 2. With the token-bus method, the maximum number of nodes in an Optical Bus System with optical bus nodes (i.e., model numbers ending in CLK11) is 32 (node addresses 1 to 32). The total number of words that can be transmitted in a data link is 32,000 words max.
 3. Refer to *Appendix B Standard Models* for information on the CX-Net.
 4. CS-series, CVM1, and CV-series PLCs do not have an LR Area, and words LR000 to LR199 are automatically converted to CIO 1000 to 1199 for use.
 5. Duplex operation of Communications Units is possible only for the CS1W-CLK13/12-V1 or CS1W-CLK53/52-V1 mounted to a CS1D PLC in token-ring mode.

1-2-5 Controller Link Unit Models and PLCs

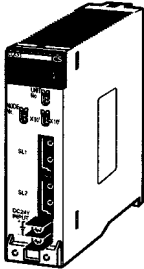
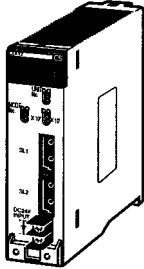
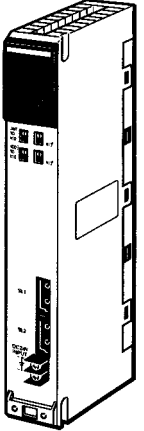
Item	Specifications		
	Optical Bus	Optical Ring (H-PCF)	
Type	Optical Bus	Optical Ring (H-PCF)	
Model	CS1W-CLK11	CS1W-CLK13 CS1W-CLK12-V1	CVM1-CLK12
External appearance			
Installation devices	---	---	---
Applicable PLC	CS-series PLCs	CS-series PLCs	CVM1 and CV-series PLCs
Duplex operation	Not supported	Supported (in CS1D System)	Not supported
Storage location of network parameters and manually set data link tables.	System Setup in the CPU Bus Unit Area (DM parameters area in the CPU Unit).		
Storage location of routing tables	DM parameters area in the CPU Unit		
Weight	300 g (Not including fittings.)	300 g (Not including fittings.)	440 g (Not including fittings.)
Current consumption	470 mA	520 mA	520 mA

- Note**
1. When connecting an Optical Ring Controller Link Unit (CS1W-CLK13/12-V1 or CVM1-CLK12/12-V1) to an Optical Bus Controller Link Unit/Board (model number ending with CLK11), the Optical Ring Controller Link Unit must be set to token-bus mode and the transmission path must be connected by the daisy-chain method.
 2. The CS1W-CLK13/12-V1 or CS1W-CLK53/52-V1 can be used in duplex-operation only when mounted to a CS1D System. For details, refer to the *CS-series Duplex System Operation Manual (W405)*.

Mounting Position and Number of Mountable Units

CS1W-CLK11 Optical Bus Controller Link Unit

Install onto a CPU Backplane or CS-series Expansion Backplane (Classified as a CPU Bus Unit.)

4 Units maximum including other types

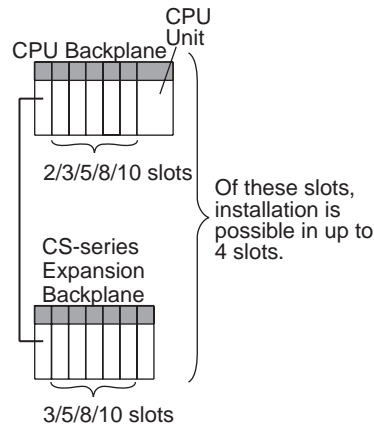

CS1W-CLK13 and CS1W-CLK12-V1 Optical Ring Controller Link Units

CS1 or CS1-H CPU Unit

Install onto a CPU Backplane or CS-series Expansion Backplane (Classified as a CPU Bus Unit.)

4 Units maximum including other types

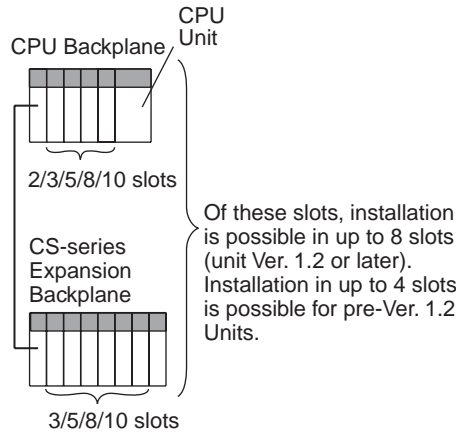

CS1D CPU Unit

Install onto a Backplane supporting duplex operation of CPU Units or an Expansion Backplane supporting online replacement (Classified as a CPU Bus Unit.)

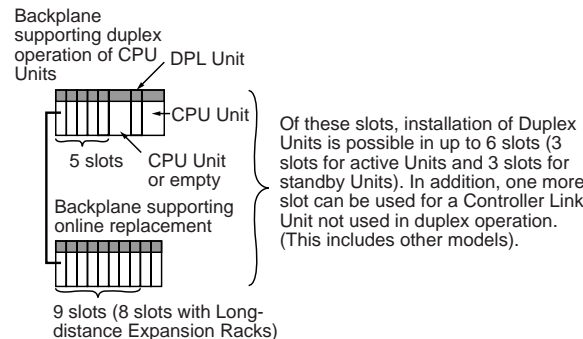

CS1W-CLK12 Optical Ring Controller Link Unit

Install onto a CPU Backplane or CS-series Expansion Backplane (Classified as a CPU Bus Unit.)

4 Unit maximum including other types

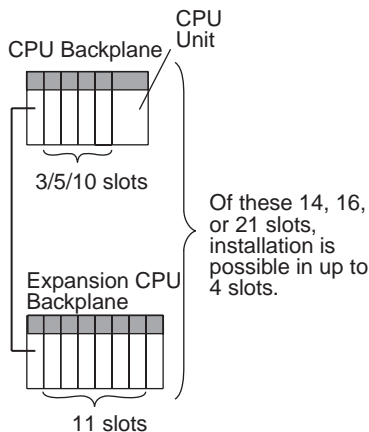

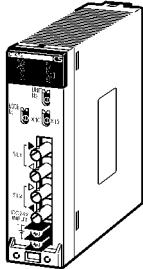
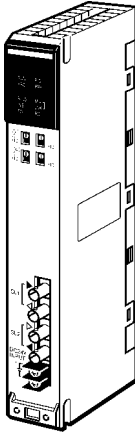
Item	Specifications	
Type	Optical Ring (GI)	
Model	CS1W-CLK53 CS1W-CLK52-V1	CVM1-CLK52
External appearance		
Installation devices	---	---
Applicable PLC	CS-series PLCs	CVM1 and CV-series PLCs
Duplex operation	Supported (in CS1D System)	Not supported
Storage location of network parameters and manually set data link tables.	System Setup in the CPU Bus Unit Area (DM parameters area in the CPU Unit).	
Storage location of routing tables	DM parameters area in the CPU Unit	
Weight	300 g (Not including fittings.)	450 g (Not including fittings.)
Current consumption	650 mA	600 mA

Note The CS1W-CLK13/12-V1 and CS1W-CLK53/52-V1 can only be used in duplex operation if they are mounted to a CS1D System. For details, refer to the *CS-series Duplex System Operation Manual (W405)*.

Mounting Position and Number of Mountable Units

CS1W-CLK53 and CS1W-CLK52-V1 Optical Ring Controller Link Units

CS1 or CS1-H CPU Unit

Install the Controller Link Unit onto a CPU Backplane or CS-series Expansion Backplane. (The Controller Link Unit is classified as a CPU Bus Unit.)

4 maximum including other types of Controller Link Units

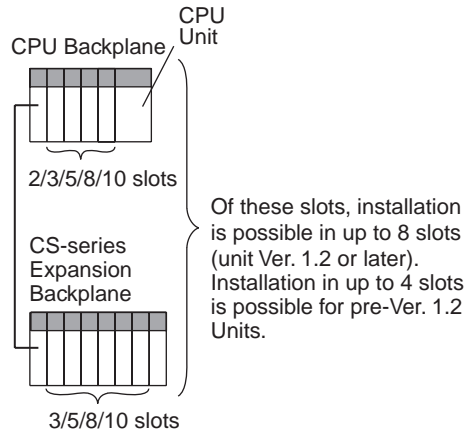

CS1D CPU Unit

Install the Controller Link Unit onto a Backplane supporting duplex operation of CPU Units or an Expansion Backplane supporting online replacement. (The Controller Link Unit is classified as a CPU Bus Unit.)

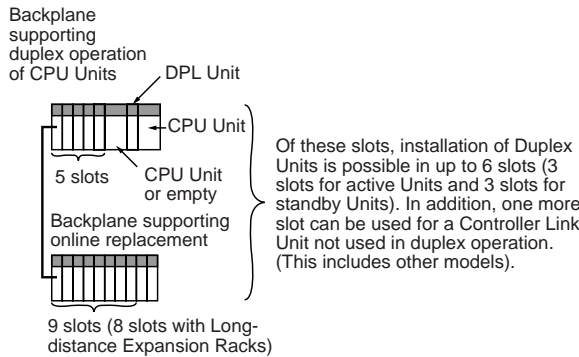

CS1W-CLK52 Optical Ring Controller Link Unit

Install the Controller Link Unit onto a CPU Backplane or CS-series Expansion Backplane. (The Controller Link Unit is classified as a CPU Bus Unit.)

4 maximum including other types of Controller Link Units

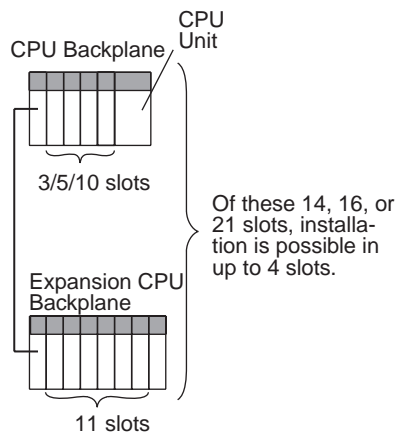

Up to eight CS-series Controller Link Units with unit version 1.2 or later can be connected to a single CPU Unit. When connecting multiple Controller Link Units to the CPU Unit, consider the current consumption of the CPU Unit and each CPU Bus Unit before selecting the Power Supply Unit. For details on Controller Link Unit current consumption, refer to *Controller Link Unit Models and PLCs* on page 17. For details on current consumption of each Unit, refer to the *SYSMAC CS Series Programmable Controllers Operation Manual* (W339).

The following table provides an example of current consumption

Example: Using the C200HW-PA209R Power Supply Unit supplying a maximum current of 9.0 A (5 V) and maximum power of 45 W.

Name	Model	Current consumption per Unit (A)	Number of Units	Current consumption (A)
CPU Backplane (8 slots)	CS1W-BC083	0.11 A	1	0.11 A
CPU Unit	CS1H-CPU67H	0.82 A	1	0.82 A
Controller Link Unit (Optical)	CS1W-CLK52-V1	0.65 A	8	5.20 A
Total				6.13 (power consumption: 30.65 W)

1-2-6 Devices Required for Connection

To set up a Controller Link Network the following devices are needed in addition to a Controller Link Unit and a PLC.

Communications Cables

Optical Bus or Optical Ring System (H-PCF Cable)

The following devices are required for the Optical Bus or Optical Ring (H-PCF) Controller Link Network. The cable and connectors are the same as those used for Optical SYSMAC LINK Networks.

Optical Fiber Cables (Indoor Use Only)

Use the following Optical Fiber Cables (Hard Plastic-clad Fiber: H-PCF).

Name	Specifications		Model
H-PCF cables	Black	10 m	S3200-HCCB101
		50 m	S3200-HCCB501
		100 m	S3200-HCCB102
		500 m	S3200-HCCB502
		1,000 m	S3200-HCCB103
	Orange	10 m	S3200-HCCO101
		50 m	S3200-HCCO501
		100 m	S3200-HCCO102
		500 m	S3200-HCCO502
		1,000 m	S3200-HCCO103

Note The Optical Fiber Cable model numbers are as follows.

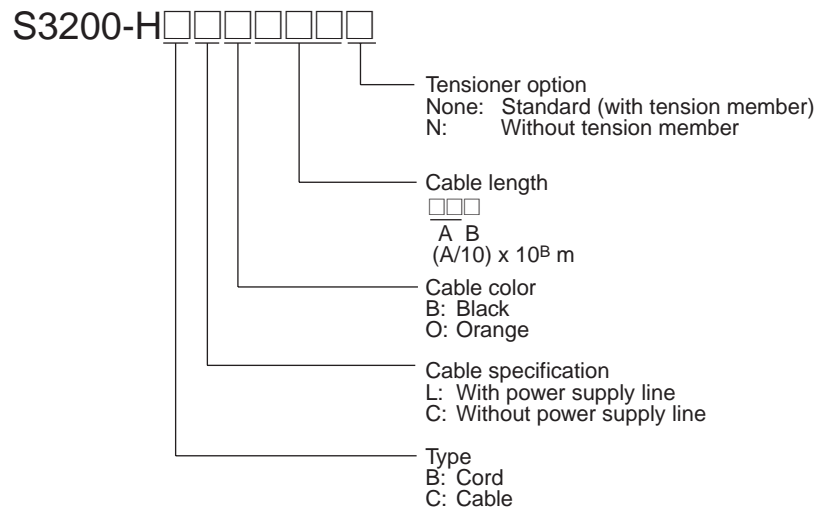

Name	Model	Specifications
Connector	S3200-COCF2071	Use to connect a cable to a node. (Full-lock connector for crimp-cut cable.)
	S3200-COCF2571	Use to connect a cable to a node. (Half-lock connector for crimp-cut cable.)
Inline Adapter	S3200-COAT2000	Use to connect or extend cables. (Use one adapter for each connection.)

Discontinued Models

Name	Model	Recommended replacement	Manufacturer
Optical Connector	S3200-COCF2011	S3200-COCF2071	OMRON
	S3200-COCF2511	S3200-COCF2571	

- Note**
1. Either full-lock or half-lock connectors can be used in a Controller Link Network, but we recommend full-lock connectors to prevent accidental disconnections during operation.
 2. The maximum distance between nodes is slightly shorter for connectors with crimp-cut cables compared to connectors assembled with adhesive. Also, the maximum distance is reduced due to extension loss when Inline Adapters are used to extend cables.

Optical Fiber Cables with Connectors (Indoor Use Only)

The following glue-and-polish Optical Fiber Cables are available with Connectors already attached.

Specifications	Length	Model
Optical Fiber Cable Connectors: S3200-COCF2071 ↓ S3200-COCF2071	2 m	S3200-CN201-20-20
	5 m	S3200-CN501-20-20
	10 m	S3200-CN102-20-20
	15 m	S3200-CN152-20-20
	20 m	S3200-CN202-20-20
	Over 20 m	S3200-CN-20-20 (Specify length (m) when ordering.)
Optical Fiber Cable Connectors: S3200-COCF2071 ↓ S3200-COCF2571	2 m	S3200-CN201-20-25
	5 m	S3200-CN501-20-25
	10 m	S3200-CN102-20-25
	15 m	S3200-CN152-20-25
	20 m	S3200-CN202-20-25
	Over 20 m	S3200-CN-20-25 (Specify length (m) when ordering.)
Optical Fiber Cable Connectors: S3200-COCF2571 ↓ S3200-COCF2571	2 m	S3200-CN201-25-25
	5 m	S3200-CN501-25-25
	10 m	S3200-CN102-25-25
	15 m	S3200-CN152-25-25
	20 m	S3200-CN202-25-25
	Over 20 m	S3200-CN-25-25 (Specify length (m) when ordering.)

- Note**
1. Consult a specialist tradesman if cables with outdoor specifications are required.
 2. The cables listed above are black and have power supply lines and tension members, although the power supply lines are not used in the Controller Link Support Board. Some Controller Link devices use tension members.
 3. All of the cables listed above are attached to the connectors with adhesive.
 4. Special training is required to assemble Optical Fiber Cables and connectors with adhesive.

Duplex Unit Connecting Cable

This cable is used to connect Controller Link Units (CS1W-CLK13 or CS1W-CLK12-V1) used in duplex operation in a CS1D System.

Name: Duplex Unit Connecting Cable

Length: 50 cm

Model number: CS1D-CN051

- Note**
1. This cable (CS1D-CN051) is used to connect Controller Link Units used in duplex operation. To connect standard nodes, use an Optical Fiber Cable with a connector (S3200-CN□□□-□□-□□). (Use a cable of at least 50 cm in length.)
 2. Controller Link Units (CS1W-CLK13 or CS1W-CLK12-V1) used in duplex operation can also be connected by a standard H-PCF cable. (Use a cable no longer than the maximum allowable distance between standard nodes.)

Optical Fiber Cable Accessories

Use the following accessories to assemble and test Optical Fiber Cables.

Name	Model	Specifications
Optical Fiber Assembly Tool	CAK-0057 (See note.)	Crimp-cut tool for the S3200-COCF2071/2571 Connectors
Optical Power Tester	CAT-2700	With CAT-2702 Head Unit and adapter for the S3200-COCF2071/2571 Connectors
Master Fiber Set	CAT-2001H	One meter cable for use with the CAT-2702 Head Unit

Note The S3200-COCF2071/2571 Optical Connector can still be assembled if the JRFK-57PLUS (Sumitomo Electric Industries) is added to the S3200-CAK1062.

Discontinued Models

Name	Model	Specifications	Manufacturer
Optical Connector Assembly Tool	S3200-CAK1062	Optical connector: S3200-COCF2011/2511	OMRON

This manual does not provide details on Optical Fiber Cable preparation. For details, refer to the instructions provided with the S3200-CAK1062 Assembly Tool.

Optical Ring System (GI Cable)

The following devices are required for the Optical Ring (GI) Controller Link Network.

Optical Fiber Cables

Use Optical Fiber Cables (Graded Index: GI) with the following optical specifications.

50/125 μm AGF Cable

Item	Minimum	Standard	Maximum	Unit	Conditions	
Numerical Aperture (N.A.)	---	0.21	---	---	Theoretical value	
Transmission loss	---	---	3.0 Lf	dB	0.5 km ≤ Lf	λ = 0.8 μm T _a = 25°C
			3.0 Lf + 0.2		0.2 km ≤ Lf < 0.5 km	
			3.0 Lf + 0.4		Lf < 0.2 km	
Connection loss	---	---	1.0		λ = 0.8 μm, one location	
Transmission bandwidth	500	---	---	MHz·km	λ = 0.85 μm (LD)	

Note L_f is fiber length in km, T_a is ambient temperature, and λ is the peak wavelength of the test light source.

62.5/125 μm AGF Cable

Item	Minimum	Standard	Maximum	Unit	Conditions	
Numerical Aperture (N.A.)	---	0.28	---	---	Theoretical value	
Transmission loss	---	---	3.5 Lf	dB	0.5 km ≤ Lf	λ = 0.8 μm T _a = 25°C
			3.5 Lf + 0.2		0.2 km ≤ Lf < 0.5 km	
			3.5 Lf + 0.4		Lf < 0.2 km	
Connection loss	---	---	1.0		λ = 0.8 μm, one location	
Transmission bandwidth	200	---	---	MHz·km	λ = 0.85 μm (LD)	

Note L_f is fiber length in km, T_a is ambient temperature, and λ is the peak wavelength of the test light source.

Connectors

ST Connector

Note When connecting Controller Link Units (CS1W-CLK53 or CS1W-CLK52-V1) used in duplex operation in a CS1D System using a short GI cable, take note of the following points.

- a. The optical fiber cable must be at least 50 cm long, and must be no longer than the maximum distance nodes.
- b. Ensure that the cable does not exceed its maximum bending radius.

1-2-7 Programming Devices

A Programming Device for the PLC, the Controller Link Support Software, or CX-Programmer are needed to use a Controller Link Network.

Programming Device for the PLC

One of the following Programming Devices is necessary when using the automatically setting data links or the message service.

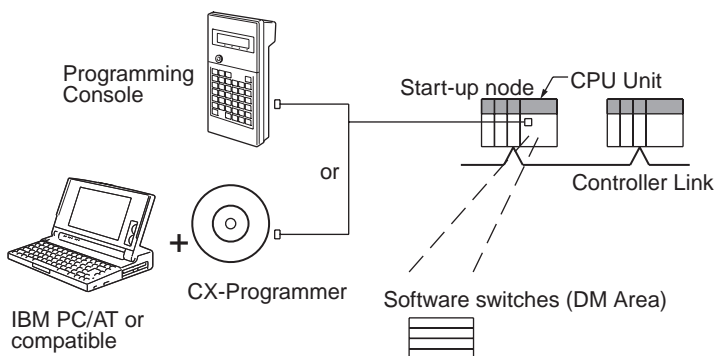

The following operations are possible.

- Selecting manual or automatic setting for data links.
- Setting the data link mode to “automatic” (software switch setting).
- Starting/stopping data links (Start Bit: ON/OFF)
- Programming for the message service.
- Reading (monitoring) the network status.

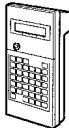
Programming Device	External appearance	Model number	Applicable PLCs
CX-Programmer (for PLC)		WS02-CXPC□-E-V□ (Ver 3.□ or higher)	CS-series, C200HX/HG/HE, CVM1-series, and CQM1H-series PLCs
Programming Console		CQM1-PRO01-E C200H-PRO27-E	C200HX/HG/HE, C200H/C200HS, CQM1, and CQM1H-series PLCs
		CVM1-PRS21-EV1	CVM1 and CV-series PLCs

Note 1. Use the CX-Net in CX-Programmer version 5.0 or higher to set data links with more than 12,000 data link send/receive words, or to set data links allocating the same area for area 1 and 2.

2. Use the CX-Integrator to set data link tables with more than 1,000 send words per node. For information on checking the CX-Integrator version number, refer to *Checking the CX-Integrator Data Link Setting Tool Version* on page viii.
3. Use CX-Programmer Ver. 3.0 or later to make settings for Duplex Communications Units in CS1D Systems.
4. For details of CX-Programmer, refer to the *CX-Programmer Operation Manual* (W425).

Controller Link Support Software (Ver. 2.00)

The Controller Link Support Software can be used to manually set data links, to set Controller Link parameters, and to monitor the Controller Link Network. The Controller Link Support Software is run on a personal computer connected to a C200HX/HG/HE, CVM1, or CV-series PLC or a personal computer in which a Controller Link Support Board has been mounted. (The Controller Link Support Software cannot be used on a computer connected directly to a CS-series PLC.) The following operations are possible.

- Setting the data link mode to “manual” (creating and storing data link tables).
- Starting/stopping data links.
- Reading (monitoring) network status.
- Reading error logs.
- Setting routing tables.
- Testing the network.
- Changing network parameters.
- Reading the network connection configuration data and status (in token-ring mode only).

Controlling the Network with a Programming Device on a Computer

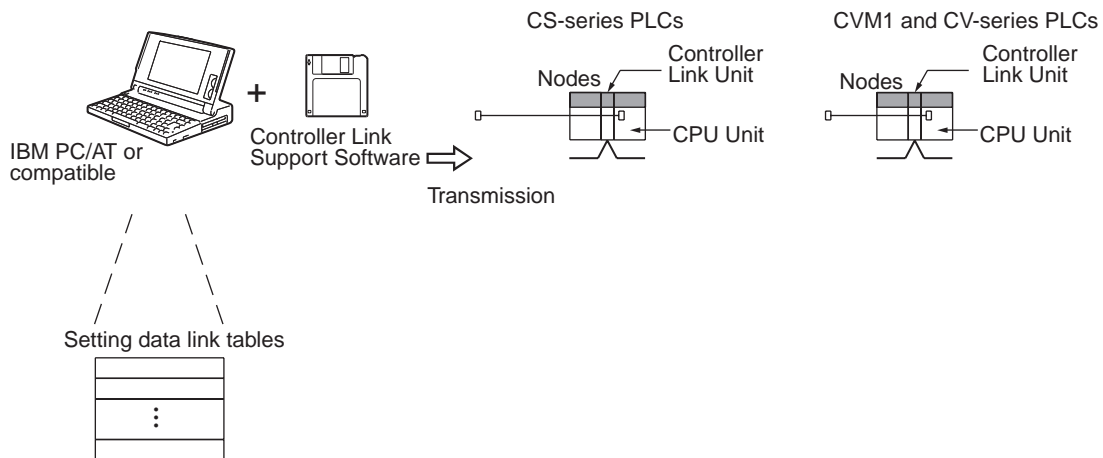

Note The Controller Link Support Software (Ver. 2.00 or later) can be used as a part of the SYSMAC Support Software.

Controlling the Network Using a Computer as a Node

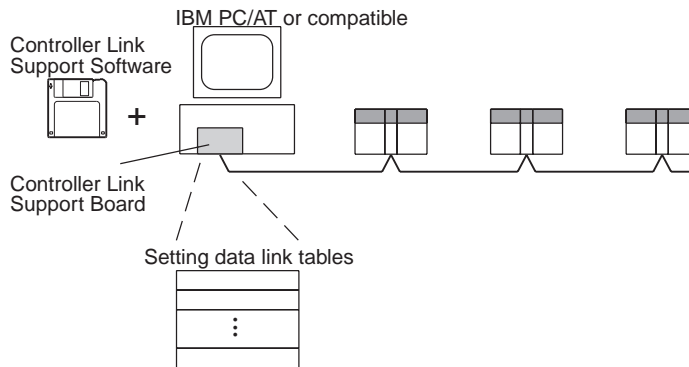

Software		External appearance	Model number	Applicable PLCs	Remarks
Controller Link Support Software (Ver. 2.00 or later)	Purchased separately		C200HW-ZW3AT2-EV2	CS-series, C200HX/HG/HE, CVM1, CV-series, or CQM1H-series PLC	For IBM PC/AT or compatible

The Controller Link Support Software can also be used with the Controller Link Support Board.

Controller Link Support Software (Ver. 1.10) is included with the Controller Link Support Board (3G8F5-CLK11-E).

Settings for Duplex Communications Units in CS1D Systems cannot be made with the Controller Link Support Software. Use CX-Programmer Ver. 3.0 or later.

Controller Link Support Software (Ver. 2.00) Menu Overview

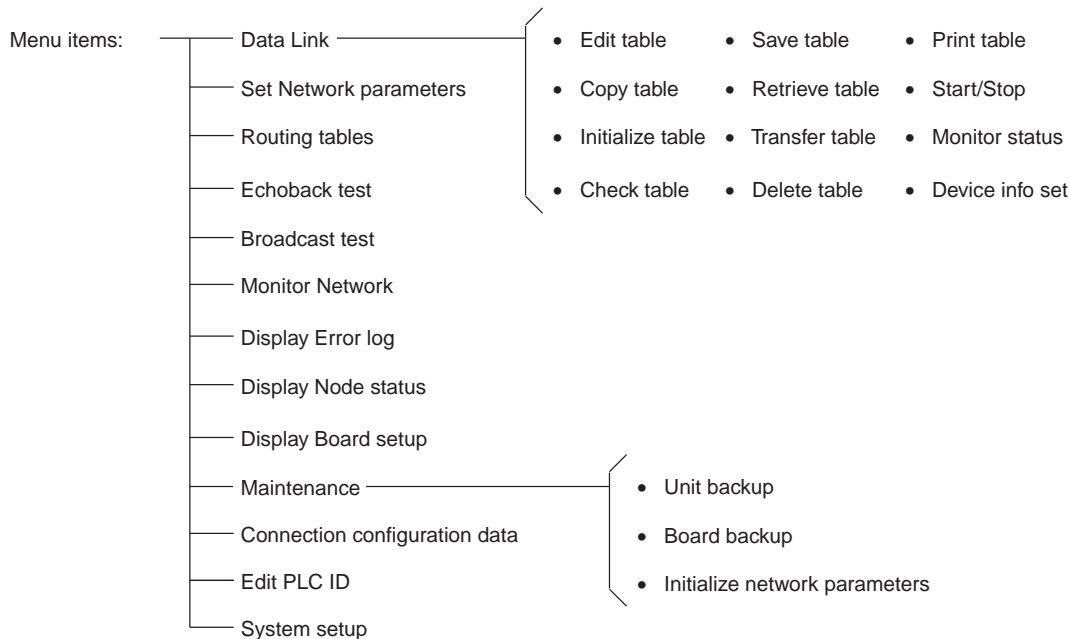

- Note**
1. Refer to the *Controller Link Support Software Operation Manual (W308)* for detailed operating procedures.
 2. Use the CX-Net in CX-Programmer version 5.0 or later to set data link areas in which the number of send and receive words exceeds 12,000, or to set data link tables that allocate the same area for Area 1 and Area 2. Controller Link Support Software cannot be used for these settings.

3. Controller Link Support Software cannot be used to set automatic creation of data links with 1:N allocations or to change data link tables while data links are running (supported by CS1W-CLK12-V1 and CS1W-CLK52-V1 for lot number 0306□□_□□□□ or later and CS1W-CLK13/53 only). Use the CX-Net in CX-Programmer version 3.2 or later to set these functions. (The first four digits of the lot number indicate the year and month of manufacture from 2000 onwards.)

CX-Net in CX-Programmer

CX-Net in CX-Programmer can be used for the following applications in a system with up to 32 nodes (node addresses 1 to 32).

- Setting the data link mode (creating and storing data link tables).
- Starting/stopping data links.
- Reading (monitoring) network status.
- Reading error logs.
- Setting routing tables.
- Testing the network.
- Changing network parameters.

Note For details on CX-Net in CX-Programmer, refer to the *CX-Programmer Operation Manual (W425)*.

Controlling the Network with a Programming Device on a Computer

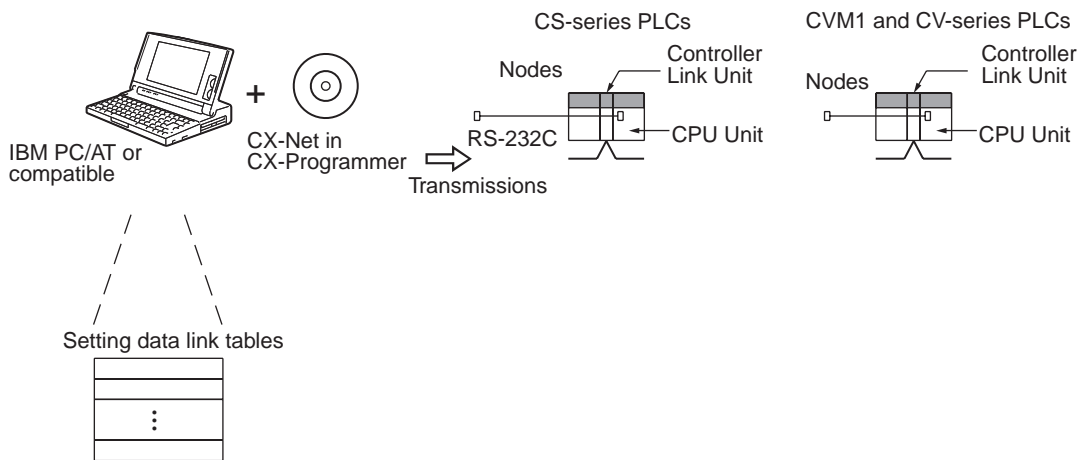

Controlling the Network Using a Computer as a Node

This configuration is possible only in token-bus mode.

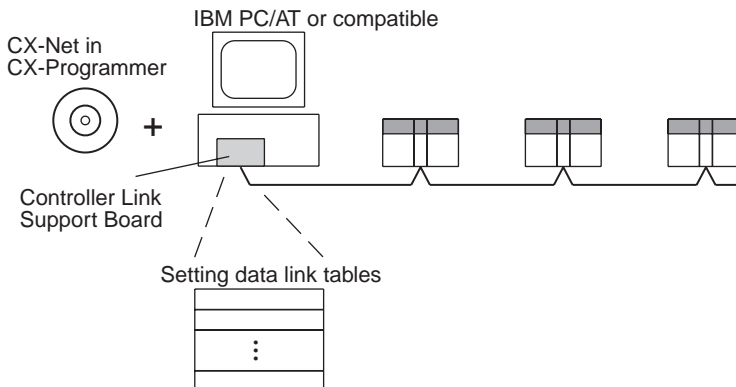

Software	External appearance	Model number	Applicable PLCs
CX-Programmer (including CX-NET)		WS02-CXPC□-E-V□ (Ver. 3.□ or higher)	CS-series, CVM1, CV-series, PLCs

Note Use the CX-Net in CX-Programmer version 3.2 or later to set automatic creation of data links with 1:N allocations or to change data link tables while data links are running (supported by CS1W-CLK12-V1 and CS1W-CLK52-V1 for lot number 0306□□_□□□□ or later and CS1W-CLK13/53 only). (The first four digits of the lot number indicate the year and month of manufacture from 2000 onwards.)

1-2-8 Backup Power Supply

The node bypass function can be used if each Controller Link Unit and Board is connected to a backup power supply. The node bypass function prevents the entire network from shutting down if the power supply to a single PLC or personal computer is interrupted.

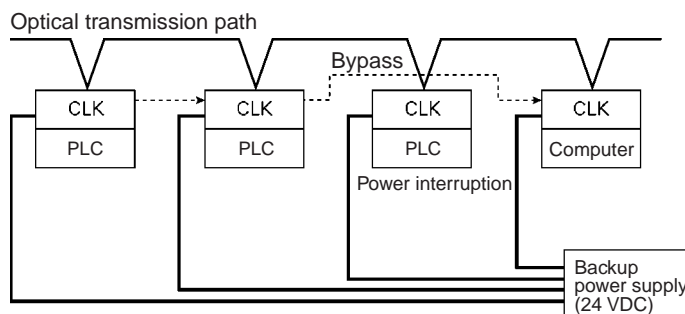

Backup Power Supply Specifications

The following table shows the input specifications required for backup power supplies to Controller Link Units and Boards. Be sure that the backup power supply being used meets these specifications. (We recommend the OMRON S82K Series.)

Item	Specification
Voltage	24 V DC
Allowed voltage fluctuation	20.4 to 26.4 V DC (24 V DC -15% to +10%)
Current consumption	200 mA max. at 24 V DC (per node)
Inrush current	2.5 A max. (with a 24-V DC startup time of 5 ms)

Note When using Controller Link Units in duplex operation in a CS1D System, provide backup power supplies for both the active and standby Controller Link Units. If the backup power supply for the standby Unit is stopped, communications will be interrupted at that point and a disconnection will be detected.

When a single power supply is connected to several nodes or is some distance away from the node, make sure that the voltage at the node itself meets the specifications in the table above. There will be some voltage drop in the power supply wiring.

The power provided from the backup power supply will be used first if a backup power supply is connected. Be sure to consider the following points when designing the network.

- 1,2,3... 1. Turn on the PLC or computer power supply after turning on the backup power supply.

2. If the backup power supply goes on or off, any data being transmitted at that moment will be corrupted.
3. Do not use the same power source to supply the backup power supply and the PLC/computer. The node bypass function will not operate if the backup power supply and the PLC/computer are both off.
4. Use a dedicated power supply for the backup power supply. Do not share a power supply being used for I/O, motors, or control systems.
Use a backup power supply that is double-insulated or one with reinforced insulation.

Always maintain the power supply voltage within specifications.

1-3 Selecting Communications Functions

Select the data link function if alarm or status data (in bits) must be constantly shared between PLCs or between a PLC and an IBM PC/AT or compatible computer or if the present value or set value data (in words) must be constantly shared between PLCs or between a PLC and an IBM PC/AT or compatible computer.

Select the message service function (SEND/RECV instructions or CMND instructions) if data (in words) must be sent (or received) from one PLC to other PLCs in other nodes or from one PLC to IBM PC/AT or compatible computers.

1-4 Basic Procedures

Preparation for Communications

- 1,2,3...
1. Perform wiring and installation.
 - Install the Unit in the PLC.
 - Connect the communications cables.
 2. Set the unit number on the front rotary switches.
 - 00 to 15 (0 to F: CS-series display is in hexadecimal)

Note When using Communications Units in duplex operation, set the same unit number for both Units in a duplex pair.
 3. Set the node address on the front rotary switches.
 - 01 to 62

Note When using Communications Units in duplex operation, set the same node address for both Units in a duplex pair.
 4. Connect power to all nodes.
 5. Connect the Programming Device to the PLC.
 6. Make the duplex settings in the PLC Setup.
 - Specify the Units used in duplex operation.
 - Specify the active Units and standby Units.

Note These settings are required only when Communications Units are used in duplex operation.
 7. Create I/O tables.

Note When I/O tables for configurations with Communications Units used in duplex operation are created, the Unit with the lower slot number will be designated as the active Unit and the Unit with the higher slot number will be designated as the standby Unit. To reverse this designation, edit the I/O tables offline and transfer them to the PLC.

8. Set the transmission path format using software switches in the DM parameters area.
 - Token-ring mode or token-bus mode

Note This setting is made for Optical Ring Controller Link Units only. (It is not required for Optical Bus Systems because the token-bus mode is always used.)

9. Register routing tables.

Note This setting is required only for connection between networks or when using CVM1 or CV-series PLCs.

Data Link Procedure

Set the data link mode in the data link parameters in the DM area of the startup node to either automatic or manual data link creation using the Programming Device.

Manually Setting Data Links

- 1,2,3... 1. Register data link tables for all nodes using the Controller Link Support Software or CX-Programmer.
2. Start the data links either using the Controller Link Support Software, CX-Programmer, or by turning ON the Start Bit from the Programming Device.

Automatically Setting Data Links

- 1,2,3... 1. Set the DM area of the startup node using the Programming Device.
2. Start the data links by turning ON the Start Bit from the Programming Device.

Message Service Procedure

Execute communications instructions in the program.

1-5 Application Precautions

- CX-Net in CX-Programmer can only be used in systems with a maximum of 32 nodes (node addresses 1 to 32). For systems with more than 32 nodes, use Controller Link Support Software (Ver. 2.00 or later).
- Turn OFF the power of all the nodes on the network before connecting or disconnecting a cable.
- Use the specified cable only.
- Be sure to set routing tables for CVM1 and CV-series PLCs. When a CVM1 or CV-series PLC is connected to the network, set routing tables at all the nodes.

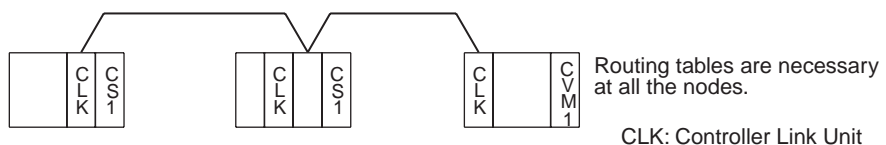

Note Routing tables are not required if all of the CVM1 and CV-series CPU Units in the Controller Link Network were manufactured on or after May 1996.

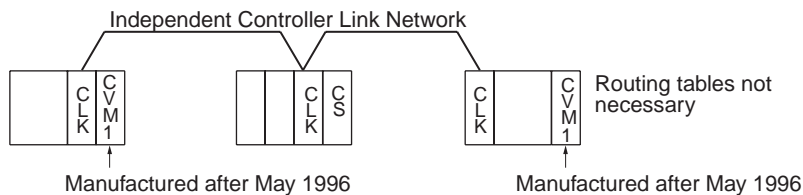

Note The manufacturing date can be determined from the four-digit lot number on the side of the CPU Unit.

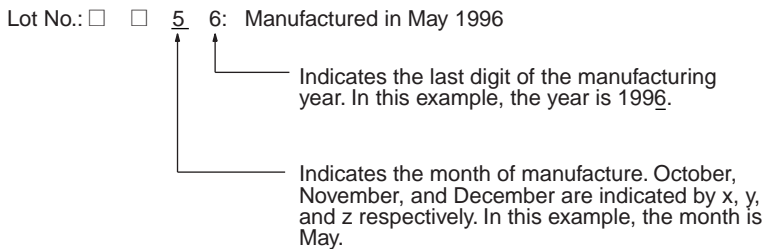

- Set routing tables at all the nodes in all the networks when multiple networks are connected.

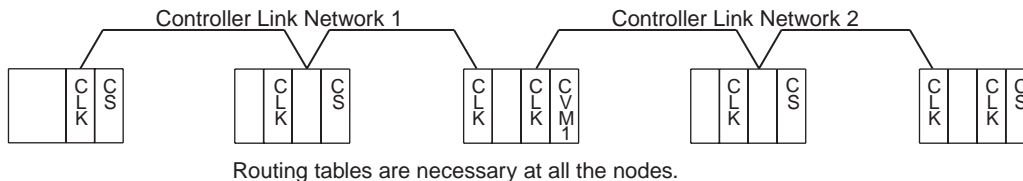

- When using the SEND/RECV or CMND instructions on a PLC for which routing tables have been set, be sure to specify the network addresses that are set in the routing tables.
- When using manually set data links, delete the data link tables from all nodes not participating in the data links.
- Do not transfer (write) routing tables when data links are active (i.e., started). CPU Bus Units and Communications Units are reset when routing tables are transferred.
- Do not restart or reset the polling node while data links are active.
- The following table shows the status of the data link refresh areas when a node registered in the data link table generates a communications error.

Communications error type	Data link areas
A node separates from the network while a data link is running.	Data received immediately prior to the error continues to be refreshed in the data link areas of the relevant nodes.
A node does not join the network after the data links start.	Zero (0) data continues to be refreshed in the data link areas of the relevant nodes.

- Automatic creation of data links with 1:N allocations is possible when all the Units are CS1W-CLK21-V1 or CJ1W-CLK21-V1 Units from lot number 0306□□_□□□□ only or either CS1W-CLK13 or CS1W-CLK53. Other Units cannot participate in data links with 1:N allocations. (The first four digits of the lot number indicate the year and month of manufacture from 2000 onwards.)

- When an Optical Ring System is used, the same transmission path format settings must be made for all of the nodes. The network cannot be set up correctly if these settings are different.
- When Optical Bus (CLK11) and Optical Ring (H-PCF cable) (CLK12, CLK12-V1, or CLK13) Controller Link Units are used in combination, observe the following precautions.
 - The transmission path format for all of the Optical Ring Controller Link Units must be set to token-bus mode. The network cannot be set up correctly if the mode settings are different.
 - All of the node addresses must be within the range of 1 to 32.
 - The software switch at the Optical Ring Controller Link Units for selecting either polling node or normal node must be set for normal node. If the Optical Ring Controller Link Unit nodes are set for polling when the network is started up, then the maximum node address in the network parameters will be set to 62, and a network parameter error (ERH indicator lit) will be generated at the Optical Bus Controller Link Unit nodes. If this occurs, use the Controller Link Support Software (Ver. 2.00 or later) to set the maximum node address to 32.
- The Optical Ring (GI cable) Controller Link Units and Boards (CLK52, CLK52-V1, or CLK53) cannot be combined with Optical Bus Controller Link Units (CLK11) or Optical Ring (H-PCF cable) Controller Link Units (CLK12, CLK12-V1, or CLK13).
- When wiring using the ring method, it is recommended that the nodes be connected in order (node 1 → node 2... → node 62 → node 1) to minimize the effect on communications time when a disconnection occurs. For details on communications time, refer to *9-2 Communications Cycle Time*.
- In CS1D Systems with Controller Link Units used in duplex operation, set the duplex node as a startup node for data links (Data Link Start/Stop Bit in the CS1D System CPU Unit is turned ON). If the duplex node is not set to be the startup node for data links (i.e., if Data Link Start/Stop Bit in the CS1D System CPU Unit is OFF), and the relevant node is operating as a polling node, the network's data links may stop if an ACT/STB (active/standby) switchover error occurs.
- In CS1D Systems, online replacement is possible also for all Controller Link Units.
- A Programming Console is required to perform online replacement.
- For precautions regarding the duplex operation of Communications Units, refer to *8-4 Precautions for Duplex Systems*.
- Communicate between the CPU Unit and Communications Units by executing the SEND(090), RECV(098), and CMND(490) instructions for the internal logic ports (8 ports max.). Up to eight Controller Link Units can be connected to a single CPU Unit with unit version 1.2 or later. Perform exclusive control of the ports using the ladder program when using the SEND(090), RECV(098), and CMND(490) instructions to perform message servicing on multiple networks (Units).
- Up to 20,000 data link send and receive words can be allocated per node (Unit) when using unit version 1.2 or later. Data of 20,000 words is divided and refreshed across three CPU Unit cycles. Make sure that the response time has been considered in the system design. Data is synchronous for each node when data is refreshed in the CPU Unit, in the same way as for earlier versions. If the number of data link words is 12,000 words or less, the response with earlier unit versions (pre-Ver. 1.2) is exactly the same.

- For details on Controller Link Unit current consumption, refer to *Controller Link Unit Models and PLCs* on page 17. For details on current consumption of each Unit, refer to the *SYSMAC CS Series Programmable Controllers Operation Manual (W339)*. For an example of calculating current consumption, refer to *Mounting Position and Number of Mountable Units* on page 20.
 - The CS1W-CLK13, CJ1W-CLK53, and 3G8F7-CLK13/53-E support up to 4,000 send words per node, but no more than 1,000 send words per node can be set if any other model of Controller Link Unit or Support Board is used in the same network.
 - If the total number of data link words is increased, the PLC cycle time and the communications cycle time will be increased. In that case, observe the following precautions.
 - Check to make sure that it will not cause problems if performance in responses to external devices is reduced.
 - In message communications, extending the communications cycle time may result in timeout errors waiting for responses. In that case, lengthen the response monitor time as described below.
- SEND, RECV, and CMND instructions:
Response monitor time setting area for local node control data.
For details, refer to *6-1 Introduction*.
- PLC Programming Devices:
PLC Programming Device *Response Timeout* setting
For details on settings, refer to the operation manual for the PLC Programming Device that is being used.

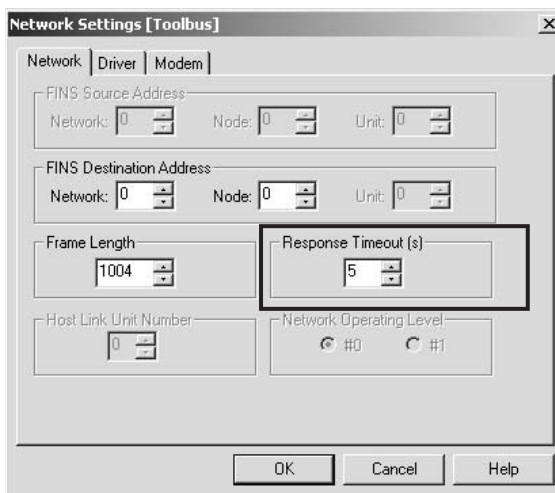

Example: CX-Programmer Response Timeout Setting

SECTION 2

Basic Procedures

This section describes the basic procedures for using the Controller Link Unit. The settings required for each of the functions are also explained briefly. For more details, refer to the subsequent sections on individual functions.

2-1	Data Links Procedures	36
2-1-1	Manually Setting Data Links	36
2-1-2	Automatically Setting Data Links	38
2-2	Message Service Procedure	44

2-1 Data Links Procedures

2-1-1 Manually Setting Data Links

When the data link mode is set for manual data link table creation, the data link tables can be input using the Controller Link Support Software or CX-Programmer. Use the following procedure.

- 1,2,3... 1. Install and wire the Units.

Contents	Method	Nodes	Page
• Mount the Units to the PLCs.	---	All nodes	59
• Wire the Network.	---	All nodes	63

2. Prepare for communications.

Contents	Method	Nodes	Page
• Set the unit number. (See note.)	Use the front rotary switches.	All nodes	77, 81
• Set the node address. (See note.)	Use the front rotary switches.	All nodes	78, 82

Note When using Controller Link Units in duplex operation, set the same unit number and node address for both Units.

3. Turn ON the power to the PLC.

Contents	Method	Nodes	Page
Turn ON the power to the PLC.	---	All nodes	---

4. Connect the Programming Device.

Contents	Method	Nodes	Page
Connect the Programming Device. Note A Programming Console can be used if there is no duplex operation.	Use the special connection cable.	All nodes	25

5. Make duplex settings for Communications Units. Create I/O tables.

Contents	Method	Nodes	Page
Make duplex settings for Communications Units (in PLC Setup).	Use the Programming Device.	Duplex nodes	207
Input the I/O tables. (See note.)	Use the Programming Console.	All nodes	208

Note When I/O tables for configurations with Communications Units used in duplex operation are created, the Unit with the lower slot number will be designated as the active Unit and the Unit with the higher slot number will be designated as the standby Unit. To reverse this designation, edit the I/O tables offline and transfer them to the PLC.

6. Set the software switches.

Contents	Method	Nodes	Page
Transmission path format setting	By Programming Device for PLC, including Programming Console. (See note a.)	All nodes.	79, 82
Data link manual/automatic setting	By Programming Device for PLC, including Programming Console. (See note b.)	Data link startup node only. Note The node that starts the data link is called the "startup node." The startup node must be determined in advance.	94
Data link status storage method setting	By Programming Device for PLC, including Programming Console. (See note c.)	All nodes.	134

Note (a) In token-ring mode, confirm that the relevant setting location in the DM parameters area is 00.

(b) For manual settings, confirm that the relevant setting location in the DM parameters area is 00.

(c) For the 8-bit storage method, confirm that the relevant setting location in the DM parameters area is 00.

(d) In token-bus mode, when Optical Bus (CLK11) and Optical Ring (CLK12, CLK12-V1, or CLK13) Controller Link Units are used in combination, the software switch at the Optical Ring Controller Link Units for selecting either polling node or normal node must be set for normal node.

7. Register the data link tables by making the following settings for each node.

Contents	Method	Nodes	Page
First data link status word	Use the Controller Link Support Software or CX-Programmer.	All nodes within the network Delete from the data link tables all nodes that are not in a data link.	94
Data link nodes			
Area 1			
First data link status words			
Numbers of data link words			
Data link offsets			
Area 2			
First data link status words			
Numbers of data link words			
Data link offsets			

Note Offsets are used to control where data is placed within the receive area.

8. Start the data links.

Contents	Method	Nodes	Page
Start the data links.	Switch the Data link Start/Stop Bit (listed below) from OFF to ON using either the Programming Device, the user program, the Controller Link Support Software or CX-Programmer.	Data link startup node (The Start Bit can be turned ON in more than one node to make sure the data links start even when the startup node is down.)	127

Note (a) Data link Start/Stop Bit (N= unit number):

CS Series: Word 0 of DM30000 + 100 × N

CVM1/CV Series: Word 0 of DM 2000 + 100 × N

(b) The data links will not start if there is an error in the data link tables in the startup node.

9. Stop the data links.

Contents	Method	Nodes	Page
Stop the data links.	Switch the Data link Start/Stop Bit (listed below) from OFF to ON using either the Programming Device, the user program, the Controller Link Support Software or CX-Programmer.	Any node that is active in the data link	127

Note Data link Start/Stop Bit (N= unit number):

CS Series: Word 0 of DM30000 + 100 × N

CVM1/CV Series: Word 0 of DM 2000 + 100 × N

2-1-2 Automatically Setting Data Links

Data link tables can be automatically created by setting the data link mode to automatic data link table creation. Use the following procedure.

1,2,3...

1. Install and wire the Units.

Contents	Method	Nodes	Page
• Mount the Units to the PLCs.	---	All nodes	59
• Wire the Network.	---	All nodes	63

2. Prepare for communications.

Contents	Method	Nodes	Page
• Set the unit number. (See note.)	Use the front rotary switches.	All nodes	77, 81
• Set the node address. (See note.)	Use the front rotary switches.	All nodes	78, 82

Note When using Controller Link Units in duplex operation, set the same unit number and node address for both Units.

3. Turn ON the power to the PLC.

Contents	Method	Nodes	Page
Turn ON the power to the PLC.	---	All nodes	---

4. Connect the Programming Device.

Contents	Method	Nodes	Page
Connect the Programming Console or Controller Link Support Software.	Use the special connection cable.	All nodes	25

5. Make duplex settings for Communications Units. Create I/O tables.

Contents	Method	Nodes	Page
Make duplex settings for Communications Units (in PLC Setup).	Use the Programming Device.	Duplex nodes	207
Create the I/O tables. (See note.)	Use the SYSMAC Support Software or Programming Console.	All nodes	208

Note When I/O tables for configurations with Communications Units used in duplex operation are created, the Unit with the lower slot number will be designated as the active Unit and the Unit with the higher slot number will be designated as the standby Unit. To reverse this designation, edit the I/O tables offline and transfer them to the PLC.

6. Set the software switches.

Contents	Method	Nodes	Page
Transmission path format setting	By Programming Device for PLC, including Programming Console. (See note a.)	All nodes.	79, 82
Data link manual/automatic setting	By Programming Device for PLC, including Programming Console. (See note b.)	Data link startup node only. Note The node that starts the data link is called the "startup node." The startup node must be determined in advance.	94
Data link status storage method setting	By Programming Device for PLC, including Programming Console. (See note c.)	All nodes.	134

- Note** (a) In token-ring mode, confirm that the relevant setting location in the DM parameters area is 00.
- (b) For the 8-bit storage method, confirm that the relevant setting location in the DM parameters area is 00.
- (c) In token-bus mode, when Optical Bus (CLK11) and Optical Ring (CLK12, CLK12-V1, CLK13) Controller Link Units are used in combination, the software switch at the Optical Ring Controller Link Units for selecting either polling node or normal node must be set for normal node.

7. Set the parameters for automatic data link creation.

Equality Layout: Previous Pattern (Supported by CS1W-CLK13, CS1W-CLK12-V1, CS1W-CLK53, CS1W-CLK52-V1, CVM1-CLK12, and CVM1-CLK52)

Contents		Method	Nodes	Page	
Set the data link mode to manual or automatic.		Use a Programming Device for the PLC, including Programming Console, to set in the CPU Unit used as the startup node.	Data link startup node only Note The node that is used to start the data links is called the startup node. The node to be used as the startup node must be determined before data links can be started.	94	
Area 1	• Set the area		Data link startup node only Note: Only when Area 1 is used	107	
	• Set the data link start word				
	• Set the number of data link words				
Area 2	• Set the area				Data link startup node only Note: Only when Area 2 is used
	• Set the data link start word				
	• Set the number of data link words				
Set the first data link status word.		Data link startup node only Note: Can also be set as not used.			
Set the number of nodes to participate in the data links.		Data link startup node only			

1:N Allocations

For pre-Ver. 1.2 CS1W-CLK13, CS1W-CLK12-V1, CS1W-CLK53, or CS1W-CLK52-V1 Controller Link Units, units from lot number 0306□□_□□□□ or later support 1:N allocations.

Lot Number notation: The first two digits refer to the year (last two digits of years from 2000 onwards), and the following two digits indicate the month (01 to 12, for January to December, respectively). (The last 7 digits are not relevant.)

• Common Type

Contents		Method	Nodes	Page
Set the data link mode to manual or automatic.		Use a Programming Device for the PLC, including Programming Console. (See note.)	Data link startup node only Note The node that is used to start the data links is called the startup node. The node to be used as the startup node must be determined before data links can be started.	94
Set the type of 1:N allocations			Data link startup node only	113
Area 1	• Set the area		Data link startup node only	
	• Set the data link start word		Note: Only when Area 1 is used	
	• Set the number of send words for the master node.			
	• Set the number of send words per slave node.			
Area 2	• Set the area		Data link startup node only	
	• Set the data link start word	Note: Only when Area 2 is used		
	• Set the number of send words for the master node.			
	• Set the number of send words per slave node.			
Set the first data link status word		Data link startup node only		
Set the nodes to participate in the data links.				

Note Use the CX-Net in CX-Programmer version 3.2 or later to automatically set data links with 1:N allocations.

• 1 to 1 Type

Contents	Method	Nodes	Page
Set the data link mode to manual or automatic.	Use a Programming Device for the PLC, including Programming Console. (See note.)	Data link startup node only Note The node that is used to start the data links is called the startup node. The node to be used as the startup node must be determined before a data link can be started.	94
Set the type of 1:N allocations.		Data link startup node only	117
Set the area.			
Set the data link start word.			
Set the number of common send words for the master node.			
Set the number of individual send words for the master node.			
Set the number of send words per slave node.			
Set the first data link status word.			
Set the nodes to participate in the data links.			

Note Use the CX-Net in CX-Programmer version 3.2 or later to automatically set data links with 1:N allocations.

• Chain Type

Contents	Method	Nodes	Page
Data link manual/automatic setting	Use a Programming Device for the PLC, including the Programming Console. (See note.)	Data link startup node only Note The node that is used to start the data links is called the startup node. The node to be used as the startup node must be determined before data links can be started.	94
Set the type of 1:N allocations.		Data link startup node only	120
Set the area.			
Set the data link start word.			
Set the number of common send words for the master node.			
Set the number of send and receive words for each node.			
Set the first data link status word.			
Set the nodes to participate in the data links.			

Note Use the CX-Net in CX-Programmer version 3.2 or later to automatically set data links with 1:N allocations.

8. Start the data links.

Contents	Method	Nodes	Page
Start the data links.	Switch the Data link Start/Stop Bit (listed below) from OFF to ON using either the Programming Device, or the user program.	Data link startup node (The Start Bit can be turned ON in more than one node to make sure the data links start even when the startup node is down.)	127

Note Data link Start/Stop Bit (N= unit number):
 CS Series: Word 0 of DM30000 + 100 × N
 CVM1/CV Series: Word 0 of DM 2000 + 100 × N

9. Stop the data links.

Contents	Method	Nodes	Page
Stop the data links.	Switch the Data link Start/Stop Bit (listed below) from OFF to ON using either the Programming Device, or the user program.	Any node that is active in the data link	127

Note (a) Data link Start/Stop Bit (N= unit number):
 CS Series: Word 0 of DM30000 + 100 × N
 CVM1/CV Series: Word 0 of DM 2000 + 100 × N

(b) The data links will not start if there is an error in the data link tables in the startup node. Data links can be started and stopped using the Controller Link Support Software.

2-2 Message Service Procedure

The following steps outline the basic procedure for using the message service.

1,2,3... 1. Install and wire the Units.

Contents	Remarks	Page
• Mount the Units to the PLCs.	---	59
• Wire the Network.	---	63

2. Prepare for communications.

Contents	Remarks	Page
• Set the unit number.	---	77, 81
• Set the node address.	---	78, 81

3. Turn ON the power to the PLC.

Contents	Remarks	Page
Turn ON the power to the PLC.	---	---

4. Connect the Programming Device.

Contents	Remarks	Page
Connect the Programming Device. Note A Programming Console can be used if there is no duplex operation.	---	25

5. Make duplex settings for Communications Units. Create I/O tables.

Contents	Remarks	Page
Make duplex settings for Communications Units (in PLC Setup).	Required only for duplex nodes.	207
Create the I/O tables. (See note.)	---	208

Note When I/O tables for configurations with Communications Units used in duplex operation are created, the Unit with the lower slot number will be designated as the active Unit and the Unit with the higher slot number will be designated as the standby Unit. To reverse this designation, edit the I/O tables offline and transfer them to the PLC.

6. Set the software switch.

Contents	Remarks	Page
Transmission path format setting (See note a.)	---	78, 82

Note (a) This setting is made by means of a Programming Device (including the Programming Console) for the PLC. In token-ring mode, confirm that the relevant setting location in the DM parameters area is 00.

(b) In token-bus mode, when Optical Bus (CLK11) and Optical Ring (CLK12, CLK12-V1, or CLK13) Controller Link Units are used in combination, the software switch at the Optical Ring Controller Link Units for selecting either polling node or normal node must be set for normal node.

7. Register routing tables if using inter-network connections.

Contents	Remarks	Page
• Set the local network table	---	190
• Set the relay network table	---	

Note Routing tables are required if any of the CVM1 and CV-series CPU Units in the Network has been manufactured on or before April 1996.

Lot No.: 4 6 Manufactured in April 1996

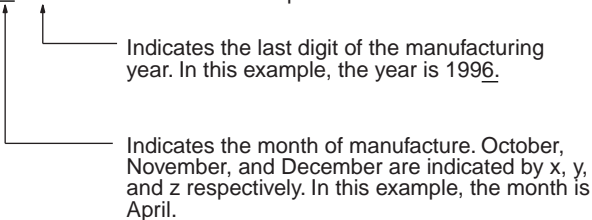

8. Create the user program.

Contents	Remarks	Page
• Prepare the send and receive data in memory.	Stored in the memory areas of the local node	142
• Prepare the control data for the communications instruction.		
• Check the conditions for executing the SEND/RECV or CMND instruction.	The standard input conditions are the Active Node Flags for the local and remote nodes, and the Port Enabled Flag.	154
• Execute the SEND/RECV or CMND instruction.	---	
• Execute other instructions are required for the results of the communications instruction, (e.g., retry or error processing if an error occurs).	The standard input condition is the Port Error Flags. CVM1 and CV-series PLCs have 8 communications ports. When 9 or more communications instructions are executed at the same time, exclusive control is necessary.	

SECTION 3

Installation and Wiring

This section explains how to install a Controller Link Unit onto a CPU Backplane and how to wire the Controller Link Network.

3-1	Component Names and Functions	48
3-1-1	CS-series Optical Ring Controller Link Units (H-PCF Cable)	48
3-1-2	CVM1 and CV-series Optical Ring Controller Link Units (H-PCF Cable)	51
3-1-3	CS-series Optical Ring Controller Link Units (GI Cable)	54
3-1-4	CVM1 and CV-series Optical Ring Controller Link Units (GI Cable)	57
3-2	Installation	59
3-2-1	CVM1 and CV-series PLCs	60
3-2-2	CS1 and CS1-H PLCs	61
3-2-3	CS1D PLCs	62
3-3	Optical Wiring	63
3-3-1	Optical Fiber Cable Connections for H-PCF Cable	63
3-3-2	Optical Fiber Cable Connections for GI Cable	65
3-3-3	Backup Power Supply Wiring	67
3-3-4	Connecting Optical Fiber Cable to Connectors for H-PCF Cable	68
3-3-5	Connecting Optical Fiber Cable to Connectors for GI Cable	70
3-3-6	Connecting Backup Power Supply Cables	73

3-1 Component Names and Functions

This section describes the names and functions of the Controller Link Unit components. This section also describes the operation of the indicators.

3-1-1 CS-series Optical Ring Controller Link Units (H-PCF Cable)

CS1W-CLK13
CS1W-CLK12-V1

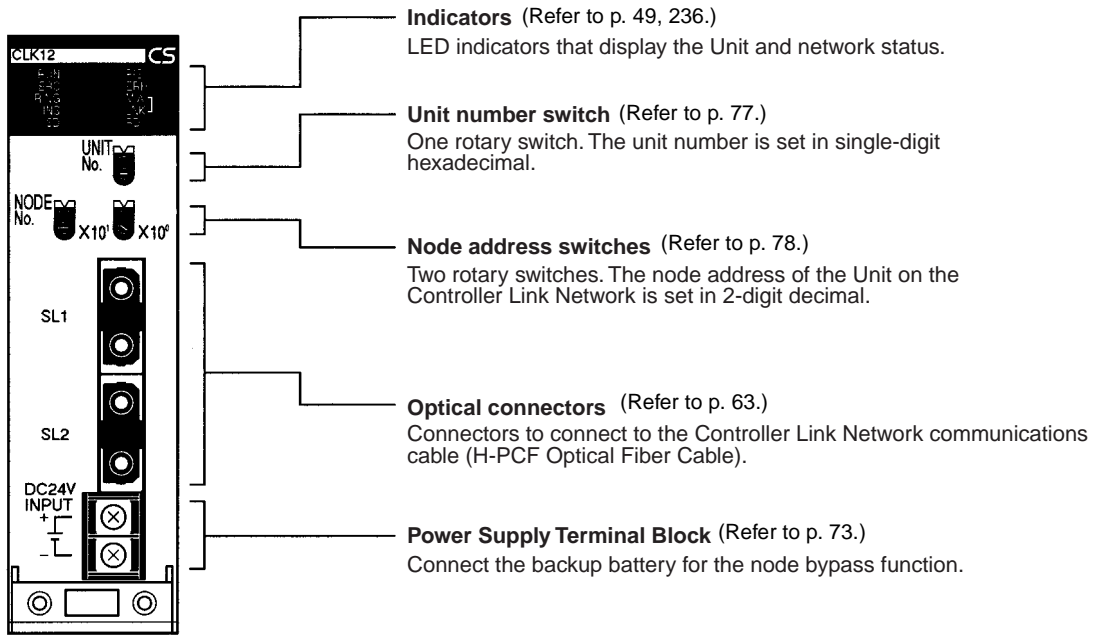

Meanings of LED Indicators

Name	Color	Status	Meaning	
RUN (operating)	Green	Lit	Unit operating normally or, if Communications Units are used in duplex operation, Unit operating normally in active mode.	
		Flashing	If Communications Units are used in duplex operation, Unit operating normally in standby mode.	
		Not lit	Unit error.	
P/S (power supply)	Green	Lit	Backup power is being supplied.	
		Not lit	Backup power is not being supplied.	
ERC (communications error)	Red	Lit	Communications error, node address setting error, hardware error or a connection error between the Optical Controller Link Unit and SYSMAC LINK.	
		Not lit	Normal operation	
ERH (PLC error)	Red	Lit	PLC error, PLC interface error, EEPROM error, unit number error, I/O table not set, duplex communications setting error, or duplex settings incomplete	
		Not lit	No error.	
INS (network participation)	Yellow	Lit	Unit is participating (inserted) in the network.	
		Not lit	Unit is not participating (inserted) in the network.	
SD (send)	Yellow	Lit	Data transmission.	
		Not lit	No data transmission.	
RD (receive)	Yellow	Lit	Data reception.	
		Not lit	No data reception.	
M/A (data link mode)	Yellow		Data links active in the network.	Data links not active in the network.
		Lit	Manual (See note.)	Note: M/A is always not lit when data links are not active in the network.
		Not lit	Automatic	
LNK (data link)	Yellow	Lit	Data links participating.	
		Flashing	Error in data link table.	
		Not lit	Not in a data link or data link inactive.	
RING (transmission path format)	Yellow	Lit	Token-ring mode setting (cable normal)	
		Flashing	Token-ring mode setting (cable disconnected)	
		Not lit	Token-bus mode setting	

Note Even when the local node does not participate in the data link, the indicator will be lit if there are manually set data links active on the network.

For details refer to 10-1 *Troubleshooting Using Indicators*.

Note The INS, SD, RD, M/A, LNK, and RING LED indicators on Controller Link Units in standby mode are not lit.

Dimensions (Unit: mm)

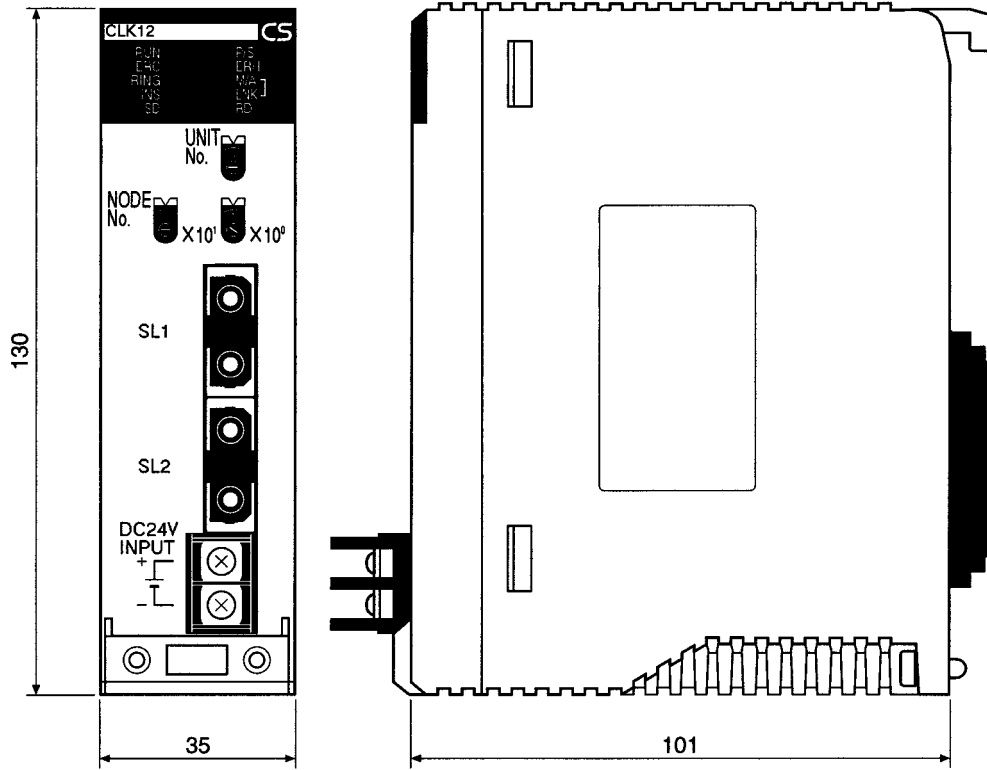

3-1-2 CVM1 and CV-series Optical Ring Controller Link Units (H-PCF Cable)

CVM1-CLK12

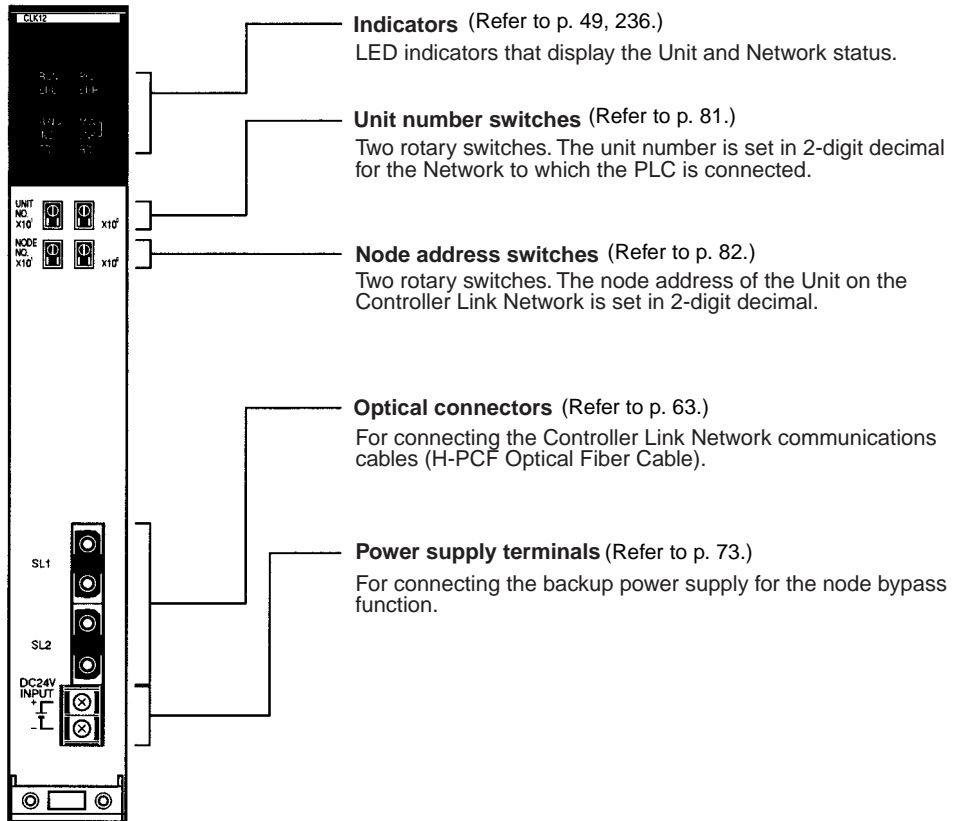

Meanings of LED Indicators

Name	Color	Status	Meaning	
RUN (operating)	Green	Lit	Unit operating normally.	
		Not lit	Unit error.	
P/S (power supply)	Green	Lit	Backup power is being supplied.	
		Not lit	Backup power is not being supplied.	
ERC (communications error)	Red	Lit	Communications error, node address setting error (same address set twice), or hardware error.	
		Not lit	Normal operation	
ERH (PLC error)	Red	Lit	PLC error, PLC interface error, EEPROM error, unit number error, or I/O table not set	
		Not lit	No error.	
INS (network participation)	Yellow	Lit	Unit is participating (inserted) in the network.	
		Not lit	Unit is not participating (inserted) in the network.	
SD (send)	Yellow	Lit	Data transmission.	
		Not lit	No data transmission.	
RD (receive)	Yellow	Lit	Data reception.	
		Not lit	No data reception.	
M/A (data link mode)	Yellow		Data links active in the network.	Data links not active in the network.
		Lit	Manual (See note.)	Note: M/A is always not lit when data links are not active in the network.
		Not lit	Automatic	
LNK (data link)	Yellow	Lit	Data links participating.	
		Flashing	Error in data link table.	
		Not lit	Not in a data link or data link inactive.	
RING (transmission path format)	Yellow	Lit	Token-ring mode setting (cable normal)	
		Flashing	Token-ring mode setting (cable disconnected)	
		Not lit	Token-bus mode setting	

Note Even when the local node does not participate in the data link, the indicator will be lit if there are manually set data links active on the network.

For details refer to 10-1 *Troubleshooting Using Indicators*.

Dimensions (Unit: mm)

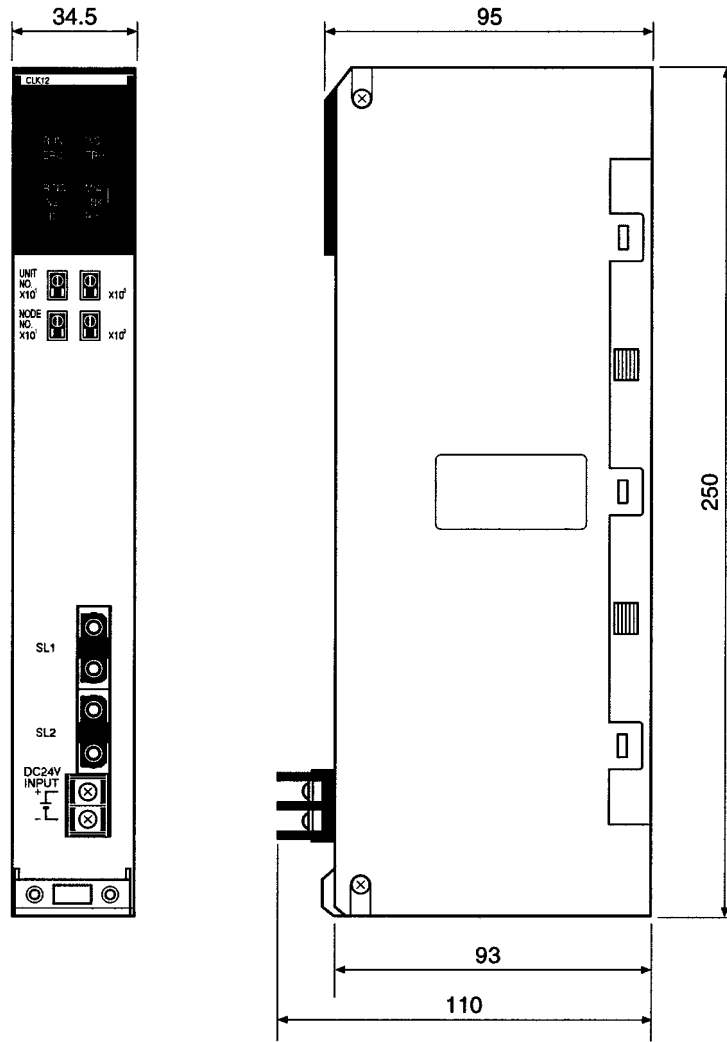

3-1-3 CS-series Optical Ring Controller Link Units (GI Cable)

CS1W-CLK53
CS1W-CLK52-V1

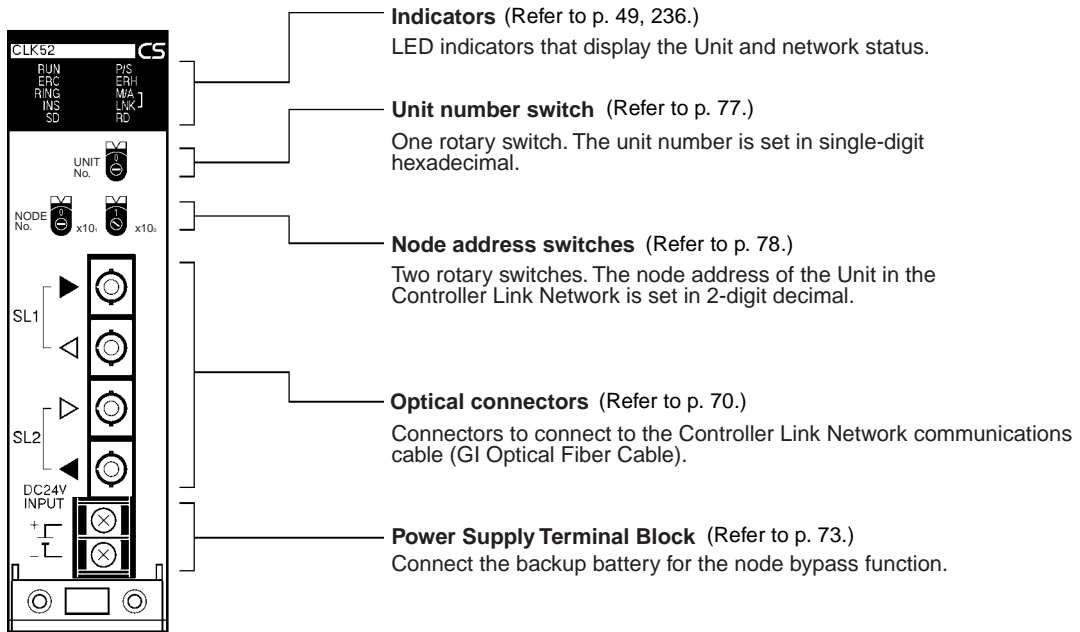

Meanings of LED Indicators

Name	Color	Status	Meaning	
RUN (operating)	Green	Lit	Unit operating normally or, if Communications Units are used in duplex operation, Unit operating normally in active mode.	
		Flashing	If Communications Units are used in duplex operation, Unit operating normally in standby mode.	
		Not lit	Unit error.	
P/S (power supply)	Green	Lit	Backup power is being supplied.	
		Not lit	Backup power is not being supplied.	
ERC (communications error)	Red	Lit	Communications error, node address setting error, hardware error or a connection error between the Optical Controller Link Unit and SYSMAC LINK.	
		Not lit	Normal operation	
ERH (PLC error)	Red	Lit	PLC error, PLC interface error, EEPROM error, unit number error, I/O table not set, duplex communications setting error, or duplex settings incomplete	
		Not lit	No error.	
INS (network participation)	Yellow	Lit	Unit is participating (inserted) in the network.	
		Not lit	Unit is not participating (inserted) in the network.	
SD (send)	Yellow	Lit	Data transmission.	
		Not lit	No data transmission.	
RD (receive)	Yellow	Lit	Data reception.	
		Not lit	No data reception.	
M/A (data link mode)	Yellow		Data links active in the network.	Data links not active in the network.
		Lit	Manual (See note.)	Note: M/A is always not lit when data links are not active in the network.
		Not lit	Automatic	
LNK (data link)	Yellow	Lit	Data links participating.	
		Flashing	Error in data link table.	
		Not lit	Not in a data link or data link inactive.	
RING (transmission path format)	Yellow	Lit	Token-ring mode setting (cable normal)	
		Flashing	Token-ring mode setting (cable disconnected)	
		Not lit	Token-bus mode setting	

Note Even when the local node does not participate in the data link, the indicator will be lit if there are manually set data links active on the network.

For details refer to 10-1 *Troubleshooting Using Indicators*.

Note The INS, SD, RD, M/A, LNK, and RING LED indicators on Controller Link Units in standby mode are not lit.

Dimensions (Unit: mm)

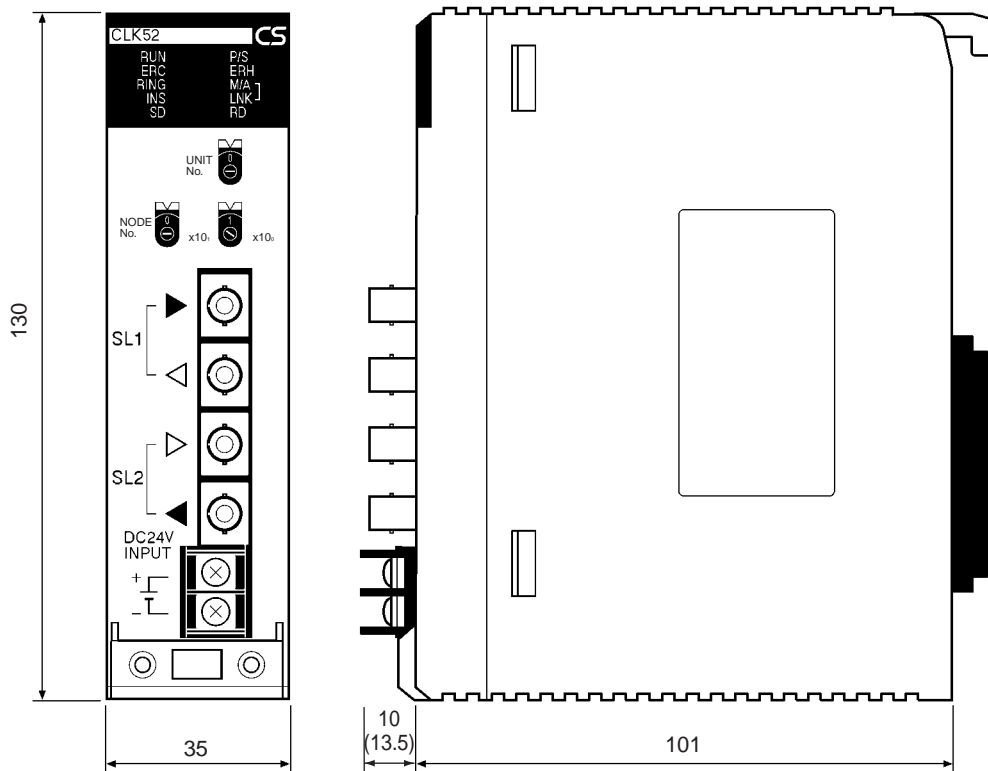

Note Dimensions given in parentheses are for the CS1W-CLK53 and include the terminal cover.

3-1-4 CVM1 and CV-series Optical Ring Controller Link Units (GI Cable)

CVM1-CLK52

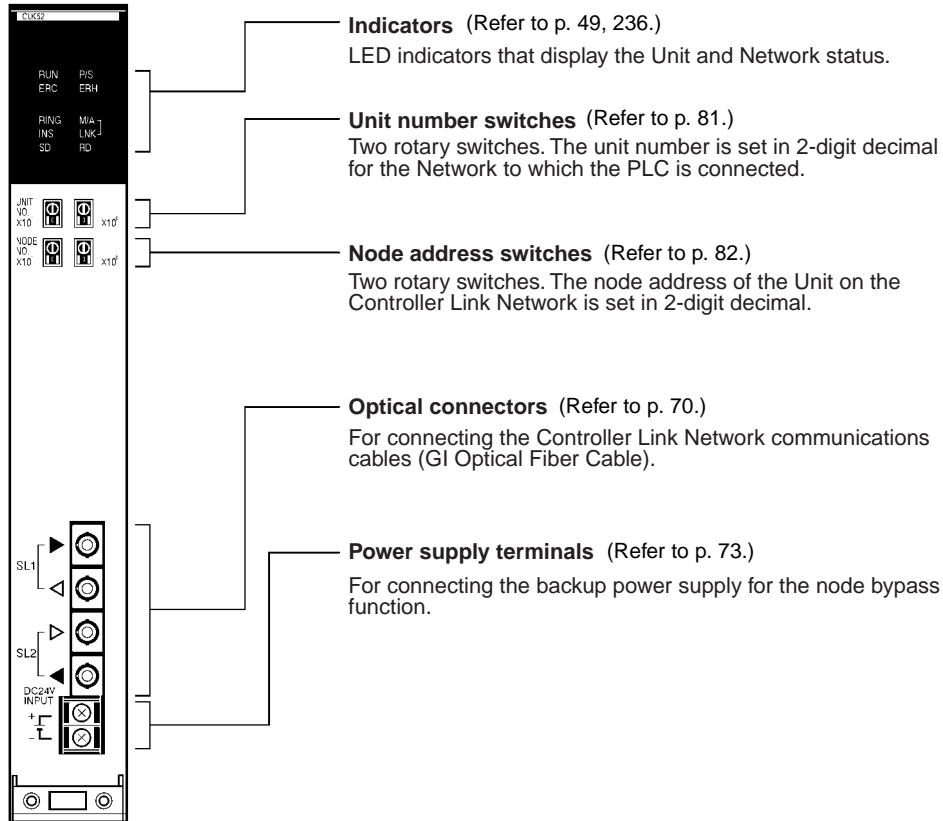

Meanings of LED Indicators

Name	Color	Status	Meaning
RUN (operating)	Green	Lit	Unit operating normally.
		Not lit	Unit error.
P/S (power supply)	Green	Lit	Backup power is being supplied.
		Not lit	Backup power is not being supplied.
ERC (communications error)	Red	Lit	Communications error, node address setting error (same address set twice), or hardware error.
		Not lit	Normal operation
ERH (PLC error)	Red	Lit	PLC error, PLC interface error, EEPROM error, unit number error, or I/O table not set
		Not lit	No error.
INS (network participation)	Yellow	Lit	Unit is participating (inserted) in the network.
		Not lit	Unit is not participating (inserted) in the network.
SD (send)	Yellow	Lit	Data transmission.
		Not lit	No data transmission.
RD (receive)	Yellow	Lit	Data reception.
		Not lit	No data reception.

Name	Color	Status	Meaning	
M/A (data link mode)	Yellow		Data links active in the network.	Data links not active in the network.
		Lit	Manual (See note.)	Note: M/A is always not lit when data links are not active in the network.
		Not lit	Automatic	
LNK (data link)	Yellow	Lit	Data links participating.	
		Flashing	Error in data link table.	
		Not lit	Not in a data link or data link inactive.	
RING (transmission path format)	Yellow	Lit	Token-ring mode setting (cable normal)	
		Flashing	Token-ring mode setting (cable disconnected)	
		Not lit	Token-bus mode setting	

Note Even when the local node does not participate in the data link, the indicator will be lit if there are manually set data links active on the network.

For details refer to *10-1 Troubleshooting Using Indicators*.

Dimensions (Unit: mm)

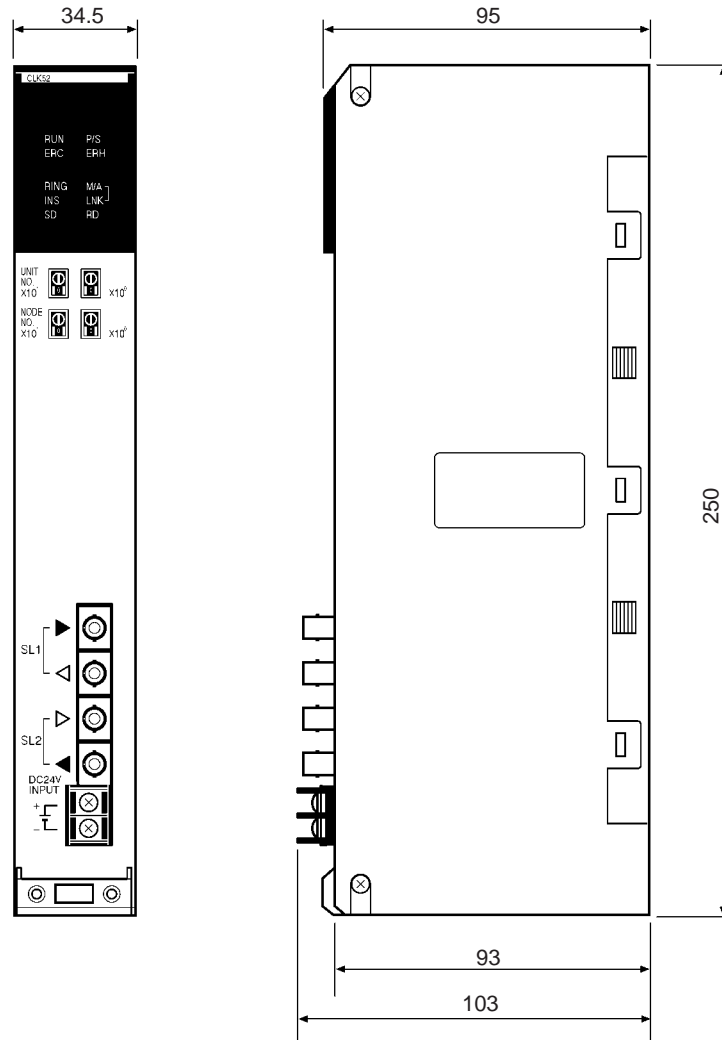

3-2 Installation

The Controller Link Unit is mounted onto a CPU Backplane or Expansion CPU Backplane for use. For detailed information on PLC installation procedures, refer to the installation guide for the applicable PLC.

- Note**
1. Always turn OFF power to the PLC before mounting the Controller Link Unit into the Backplane.
 2. Be sure that all screws on the Backplane, the Bus Connection Unit, the terminal block, and cables are tightened firmly. If screws work loose, a malfunction may occur as a result of vibration.
 3. Do not allow scraps of wire to enter the Unit when wiring the network.
 4. A label has been placed over the upper surface of the Controller Link Unit to prevent scraps of wire from entering the Unit. Conduct wiring and installation with this label in place. If wire scraps get into the Unit, it will malfunction. (CS-series Controller Link Units only)
 5. Remove the label after wiring and installing the Controller Link Unit to prevent overheating. Overheating will cause the Unit to malfunction. (CS-series Controller Link Units only)

3-2-1 CVM1 and CV-series PLCs

Up to four Controller Link Units for CVM1 and CV-series PLCs can be installed in a CPU Backplane or a Expansion CPU Rack. Controller Link Units cannot be installed on an Expansion I/O Rack, a SYSMAC BUS Slave Rack, or a SYSMAC BUS/2 Slave Rack.

The CVM1 and CV-series Controller Link Unit is classified as a CPU Bus Unit and must be mounted in a CPU bus slot.

Note Tighten the screws on the Backplane to a torque of 1.2 N·m.
Tighten the fixed screws on the CPU Unit to a torque of 0.9 N·m.

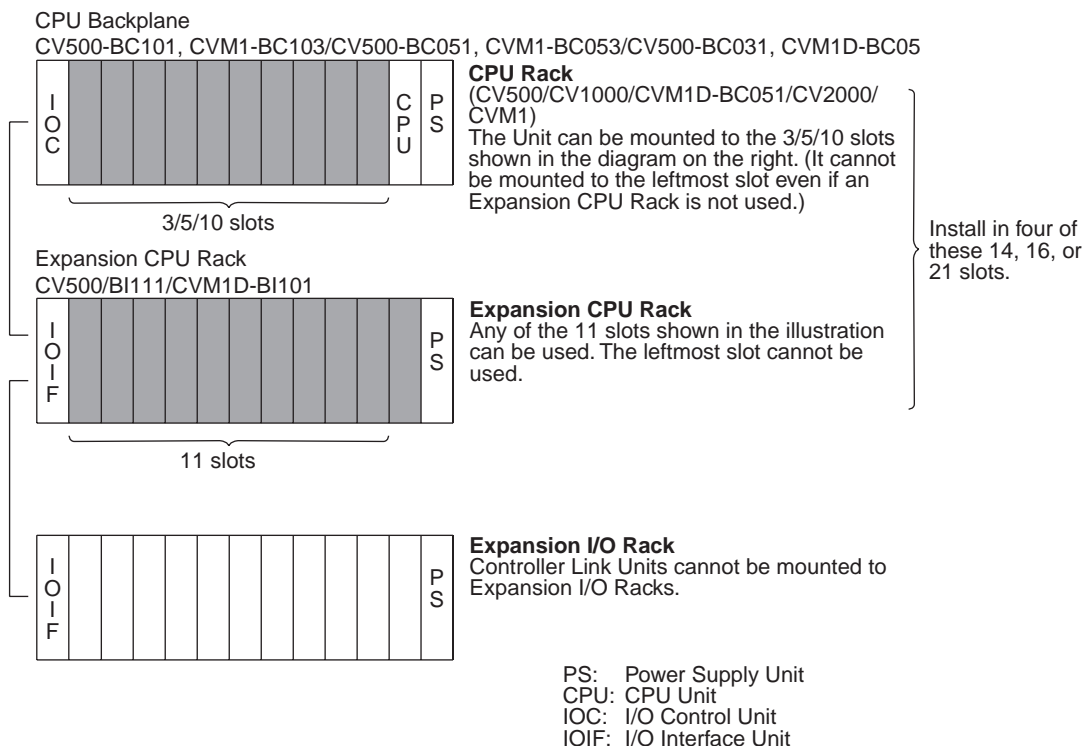

3-2-2 CS1 and CS1-H PLCs

Up to a total of eight Controller Link Units with unit version 1.2 or later (wired and optical) for CS-series PLCs (or up to four pre-Ver. 1.2 Controller Link Units) can be installed in a CPU Backplane or an Expansion CPU Rack. Controller Link Units cannot be installed on a C200H Expansion I/O Rack or a SYSMAC BUS Slave Rack.

Note Tighten the screws on the Backplane to a torque of 0.9 N·m.
Tighten the fixed screws on the CPU Unit to a torque of 0.4 N·m.

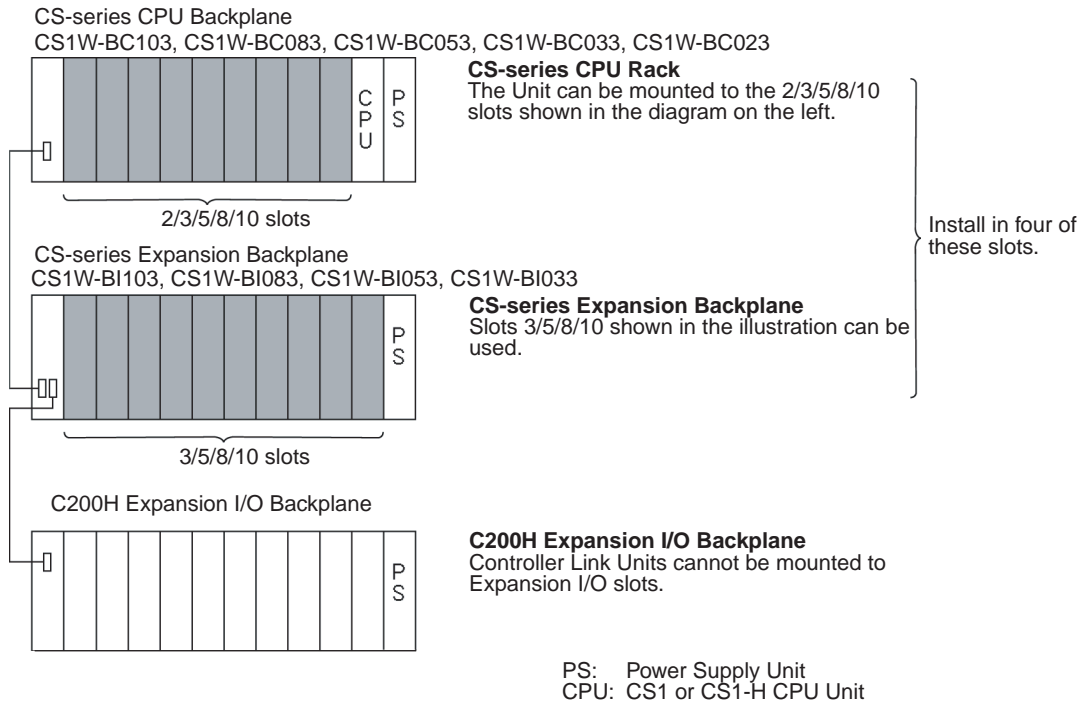

Note When installing several CS-series CPU Bus Units at the same time, a total of 16 CS-series CPU Bus Units maximum may be installed.

Up to eight CS-series Controller Link Units with unit version 1.2 or later can be connected to a single CPU Unit. When connecting multiple Controller Link Units to the CPU Unit, consider the current consumption of the CPU Unit and each CPU Bus Unit before selecting the Power Supply Unit. For details on Controller Link Unit current consumption, refer to *Controller Link Unit Models and PLCs* on page 17. For details on current consumption of each Unit, refer to the *SYSMAC CS Series Programmable Controllers Operation Manual* (W339).

The following table provides an example of current consumption

Example: Using the C200HW-PA209R Power Supply Unit supplying a maximum current of 9.0 A (5 V) and maximum power of 45 W.

Name	Model	Current consumption per Unit (A)	Number of Units	Current consumption (A)
CPU Backplane (8 slots)	CS1W-BC083	0.11 A	1	0.11 A
CPU Unit	CS1H-CPU67H	0.82 A	1	0.82 A
Controller Link Unit (Optical)	CS1W-CLK52-V1	0.65 A	8	5.20 A
Total				6.13 (power consumption: 30.65 W)

3-2-3 CS1D PLCs

Up to 3 pairs (i.e., active Unit and standby Unit) of CS-series Controller Link Units used in duplex operation and one CS-series Controller Link Unit not used in duplex operation can be mounted to a CS1D Duplex Backplane or an Expansion Backplane supporting online replacement. In other words, Units using up to 4 unit numbers can be mounted. Controller Link Units cannot be installed on an C200H Expansion I/O Rack or a SYSMAC BUS Slave Rack.

- Note**
1. Duplex operation is possible only with the CS1W-CLK13/12-V1 and CS1W-CLK53/52-V1.
 2. Tighten the screws on the Backplane to a torque of 0.9 N·m.
Tighten the fixed screws on the CPU Unit to a torque of 0.4 N·m.

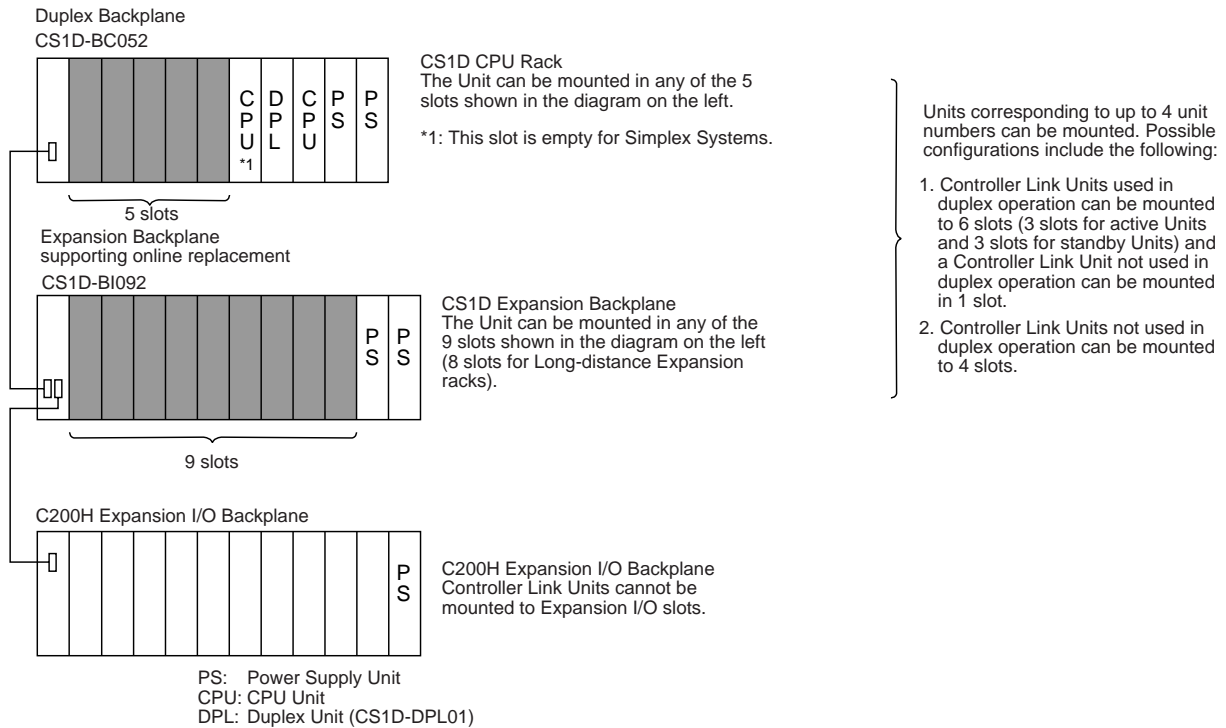

When installing several CS-series CPU Bus Units at the same time, a total of 16 CS-series CPU Bus Units maximum (not including Controller Link Units in standby mode) may be installed.

For details on the CS1D System, refer to the *CS-series Duplex System Operation Manual (W405)*.

- Note**
1. A pair of Controller Link Units used in duplex operation can be mounted in non-adjacent slots or on different Racks. Be sure, however, to connect them directly with a cable.
 2. In the CS1D System, online replacement is possible using a Programming Console. If the Controller Link Units are used in token-bus mode, however, there is a possibility of the network splitting.

3-3 Optical Wiring

3-3-1 Optical Fiber Cable Connections for H-PCF Cable

Optical Bus and Optical Ring Systems (Token-bus Mode)

All of the nodes in the network are connected in a line (daisy-chain configuration) with H-PCF Optical Fiber Cable.

The nodes can be connected in any order, but be sure to begin with the upper connector (SL1) of the highest node in the network and connect to the lower connector (SL2) in the next lower node, as shown in the following diagram.

Although there is no fixed order in which the nodes must be connected, in order to minimize the effect on communications time in the event of a disconnection, it is recommended that they be connected in order of node address (node 1 → node 2... → node 62 whenever possible).

Also be sure to cover the unused connectors on the highest and lowest nodes in the network with Optical Connector Covers.

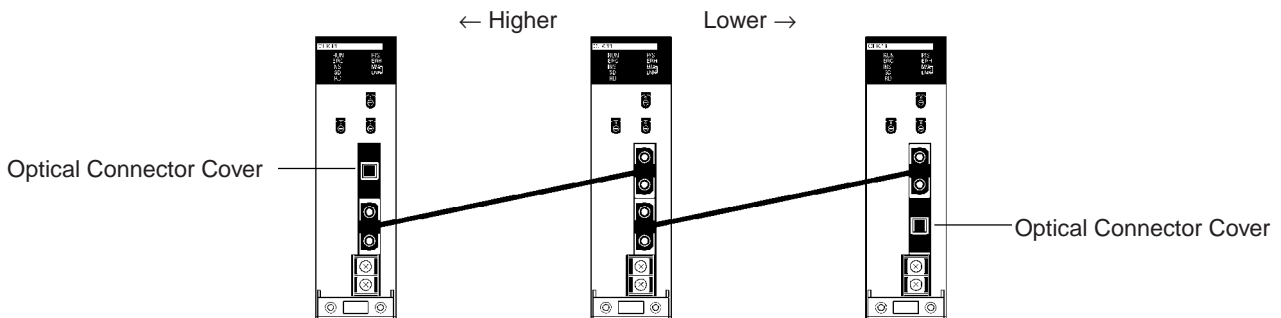

See 1-2-6 *Devices Required for Connection* for details on available H-PCF Optical Fiber Cables.

- Note**
1. Always use the specified Optical Fiber Cables.
 2. The maximum distance between nodes depends on how the cable is connected. For details, refer to the applicable Optical Fiber Cable (H-PCF) manual.
 3. In token-bus mode (daisy-chain connection), the maximum number of nodes in an Optical Bus System (i.e., Controller Link Unit model numbers ending in CLK11) with nodes is 32 (node addresses 1 to 32).
 4. Duplex operation of Communications Units is not possible in token-bus mode.
 5. Online replacement is possible in CS1D Systems but if token-bus mode is used there is a possibility of the network splitting.

Optical Ring System (Token-ring Mode) without Duplex Operation

All of the nodes in the network are connected in a ring with H-PCF Optical Fiber Cable.

The nodes can be connected in any order, but be sure to begin with the upper connector (SL1) of the highest node in the network and connect to the lower connector (SL2) in the next lower node, as shown in the following diagram.

Although there is no fixed order in which the nodes must be connected, in order to minimize the effect on communications time in the event of a disconnection, it is recommended that they be connected in order of node address (node 1 → node 2... → node 62 whenever possible).

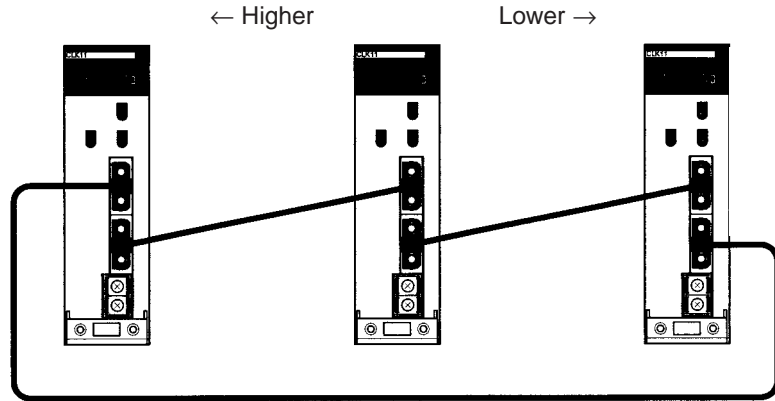

See 1-2-6 *Devices Required for Connection* for details on available H-PCF Optical Fiber Cables.

- Note**
1. Always use the specified Optical Fiber Cables.
 2. The maximum distance between nodes depends on how the cable is processed. For details, refer to the applicable Optical Fiber Cable (H-PCF) manual.

Optical Ring System (Token-ring Mode) with Duplex Operation

All of the nodes in the network (including standby Units) are connected in a ring with H-PCF Optical Fiber Cable.

The nodes can be connected in any order, but be sure to begin with the upper connector (SL1) of the highest node in the network and connect to the lower connector (SL2) in the next lower node, as shown in the following diagram.

Although there is no fixed order in which the nodes must be connected, in order to minimize the effect on communications time in the event of a disconnection, it is recommended that they be connected in order of node address (node 1 → node 2... → node 62 whenever possible).

Pairs of Controller Link Units used in duplex operation can also be connected in any order but they must be connected with special cable. (There must be no other nodes between them.)

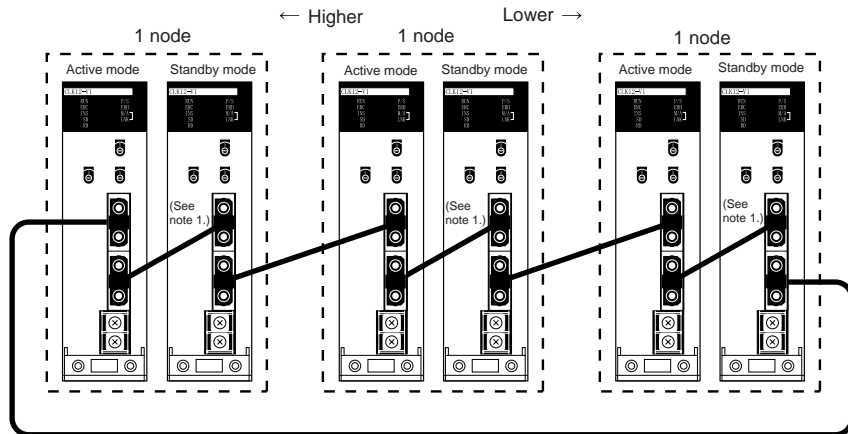

- Note**
1. Connect active and standby Controller Link Units using either the CS1D-CN051 Duplex Unit Connecting Cable or an Optical Fiber Cable with a connector (S3200-CN□□□-□□-□□). See 1-2-6 *Devices Required for Connection* for details on available H-PCF Optical Fiber Cables.
 2. Always use the specified Optical Fiber Cables.

3. The maximum distance between nodes depends on how the cable is processed. For details, refer to the applicable Optical Fiber Cable (H-PCF) manual.
4. There are no special restrictions that apply to the distance between standby Controller Link Units and higher or lower Controller Link Units. (The restrictions, however, on the maximum transmission distance for Controller Link Networks (20 km) and the maximum distance between nodes (depends on the cable construction method) must be satisfied.)
5. The standby Controller Link Unit does not participate in communications and so is not counted as a node. However, because standby Units are included in the figure for the maximum number of mountable Units (62), the maximum number of active nodes is equal to the following:
62 – Number of standby Units
6. The network can include a mixture of duplex and non-duplex nodes.

3-3-2 Optical Fiber Cable Connections for GI Cable

Optical Bus and Optical Ring Systems (Token-bus Mode)

All of the nodes in the network are connected in a line (daisy-chain configuration) with GI Optical Fiber Cable. The cables must be connected as shown in the following diagrams.



An identifying label is printed on one of the cables in each pair, so that the cables can be told apart. If the Units are connected incorrectly, the situation can be misinterpreted as a disconnection and unpredictable operation may result.

Although there is no fixed order in which the nodes must be connected, in order to minimize the effect on communications time in the event of a disconnection, it is recommended that they be connected in node-address order (node 1 → node 2... → node 62) whenever possible.

Always cover the unused connectors on the highest and lowest nodes in the network with Optical Connector Covers.

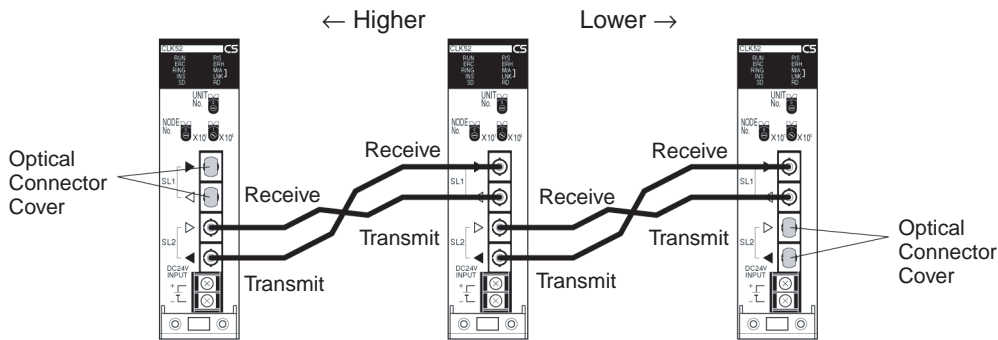

See 1-2-6 *Devices Required for Connection* for details on available GI Optical Fiber Cables.

- Note**
1. Always use the specified Optical Fiber Cables.
 2. Although the Optical Fiber Cables can be distinguished by the markings or color, in order to prevent incorrect connection it is recommended that tags are attached to the cables.

3. The maximum distance between nodes depends on the type of GI cable (core diameter) that is being used.
 62.5/125 μm cable: Max. distance between nodes = 2 km
 50/125 μm cable: Max. distance between nodes = 1 km
4. Duplex operation of Communications Units is not possible in token-bus mode.
5. Online replacement is possible in CS1D Systems but if token-bus mode is used there is a possibility of the network splitting.

Optical Ring System (Token-ring Mode) without Duplex Operation

All of the nodes in the network are connected in a ring with GI Optical Fiber Cable. The cables must be connected as shown in the following diagrams.



An identifying label is printed on one of the cables in each pair, so that the cables can be told apart. If the Units are connected incorrectly, the situation can be misinterpreted as a disconnection and unpredictable operation may result.

Although there is no fixed order in which the nodes must be connected, in order to minimize the effect on communications time in the event of a disconnection, it is recommended that they be connected in node address order (node 1 → node 2... → node 62 → node 1) whenever possible.

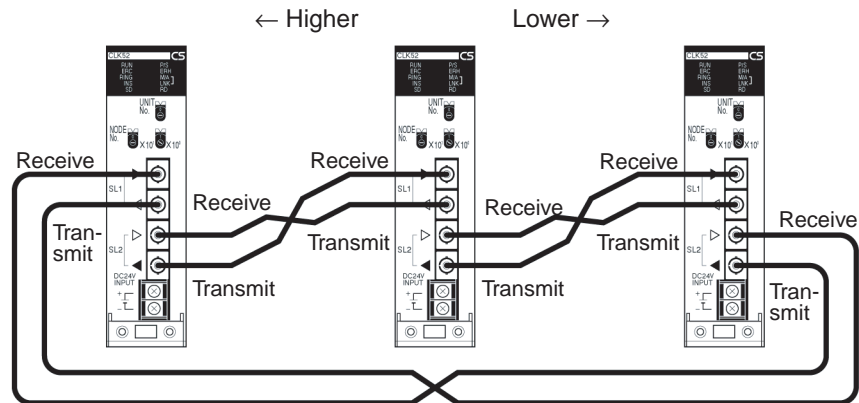

See 1-2-6 *Devices Required for Connection* for details on available GI Optical Fiber Cables.

- Note**
1. Always use the specified Optical Fiber Cables.
 2. The maximum distance between nodes depends on the type of GI cable (core diameter) that is being used.
 62.5/125 μm cable: Max. distance between nodes = 2 km
 50/125 μm cable: Max. distance between nodes = 1 km

Optical Ring System (Token-ring Mode) with Duplex Operation

All of the nodes in the network (including standby Units) are connected in a ring with GI Optical Fiber Cable. The cables must be connected as shown in the following diagrams.



An identifying label is printed on one of the cables in each pair, so that the cables can be told apart. If the Units are connected incorrectly, the situation can be misinterpreted as a disconnection and unpredictable operation may result.

Although there is no fixed order in which the nodes must be connected, in order to minimize the effect on communications time in the event of a disconnection, it is recommended that they be connected in node address order (node 1 → node 2... → node 62 → node 1) whenever possible.

Pairs of Controller Link Units used in duplex operation can also be connected in any order but they must be connected with special cable. (There must be no other nodes between them.)

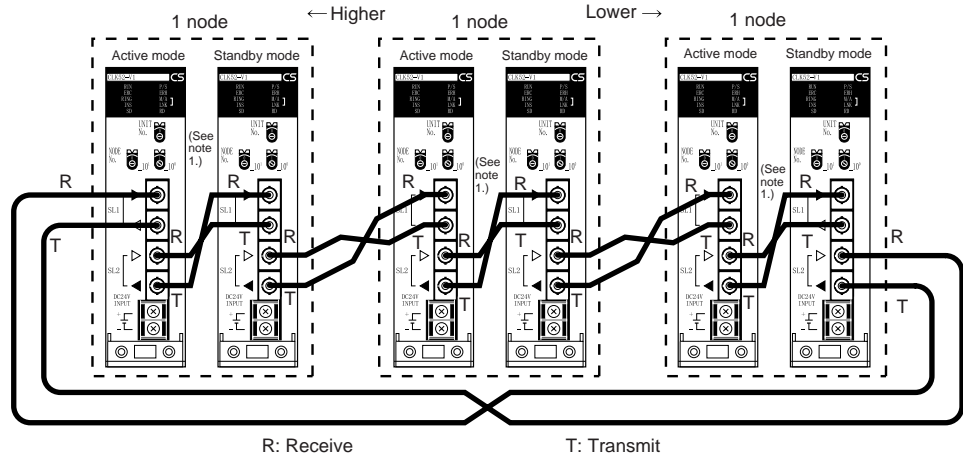

- Note**
1. Connect active and standby Controller Link Units using a GI cable (of at least 50 cm in length). See 1-2-6 *Devices Required for Connection* for details on available GI Optical Fiber Cables.
 2. Always use the specified Optical Fiber Cables.
 3. The maximum distance between nodes depends on the type of GI cable (core diameter) that is being used.
 - 62.5/125 μm cable: Max. distance between nodes = 2 km
 - 50/125 μm cable: Max. distance between nodes = 1 km
 4. There are no special restrictions that apply to the distance between standby Controller Link Units and higher or lower Controller Link Units. (The restrictions, however, on the maximum transmission distance for Controller Link Networks (30 km) and the maximum distance between nodes (depends on the cable construction method) must be satisfied.)
 5. The standby Controller Link Unit does not participate in communications and so is not counted as a node. However, because standby Units are included in the figure for the maximum number of mountable Units (62), the maximum number of active nodes is equal to the following:
 - 62 – Number of standby Units
 6. The network can include a mixture of duplex and non-duplex nodes.

3-3-3 Backup Power Supply Wiring

Each node requires a backup power supply for the node bypass function. Several nodes can be connected to a single power supply or each node can be connected to an independent power supply.

Be sure that the backup power supply is providing sufficient current and voltage at the Unit's connector. See 1-2-8 *Backup Power Supply (Optical System Only)* for the backup power supply specifications.

- Note**
1. A label has been placed over the upper surface of the CS-series Controller Link Units to prevent wire cuttings from entering the Unit. When wiring the backup power supply, leave the label in place.

2. When wiring is complete, remove the label to avoid overheating.
3. Use a power supply that is not connected to PLC operation, as in the case of the node bypass function, for the backup power supply so that when the power to the PLC is turned OFF, the backup power supply will continue.
4. Use a dedicated power supply for the backup power supply. Do not share a power supply being used for I/O, motors, or control systems.
5. When two or more nodes are connected to a single power supply, wire each node separately.

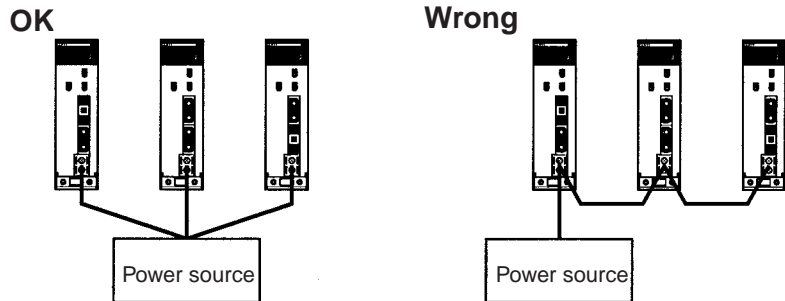

6. When using Controller Link Units in duplex operation in a CS1D System, provide backup power supplies for both the active and standby Controller Link Units. If the backup power supply for the standby Unit is stopped, communications will be interrupted at that point and a disconnection will be detected.

3-3-4 Connecting Optical Fiber Cable to Connectors for H-PCF Cable

A special connector is used to connect the Optical Fiber Cable to the Controller Link Unit.

This manual does not provide details on Optical Fiber Cable preparation.

Connect the Optical Fiber Cables to the nodes in order from higher to lower nodes. (When a ring topography is being used, connect the last node to the first node, too.)

Observe the following precautions when connecting the Optical Fiber Cables.

- Always turn OFF the PLC power supply before connecting Optical Fiber Cables (except for online replacement).
- Special tools are required to attach Optical Fiber Cables to the connectors. The cable may disconnect from the connector if the proper tools and methods are not used during cable assembly.

Connection Procedure

Use the following procedure to connect Optical Fiber Cables to a Unit.

1,2,3...

1. Tighten screws in the mounting brackets so that the through-holes on the terminal are on the top and bottom and then affix hexagonal nuts from the opposite side of the terminal.
2. Insert bushing to the mounting bracket and secure the Unit with screws.
3. Pass the tension member through the through-holes, and tighten the terminal screws to affix the tension member.
4. Affix the cable to the mounting bracket so that it is clamped by the bracket. Two cables can be attached at the same time.
5. Move the cable connector so that the loose ends are on the left-hand side, and insert the Unit's optical connector as far as it will reach.

Example: Connections for Duplex Operation of Communications Units

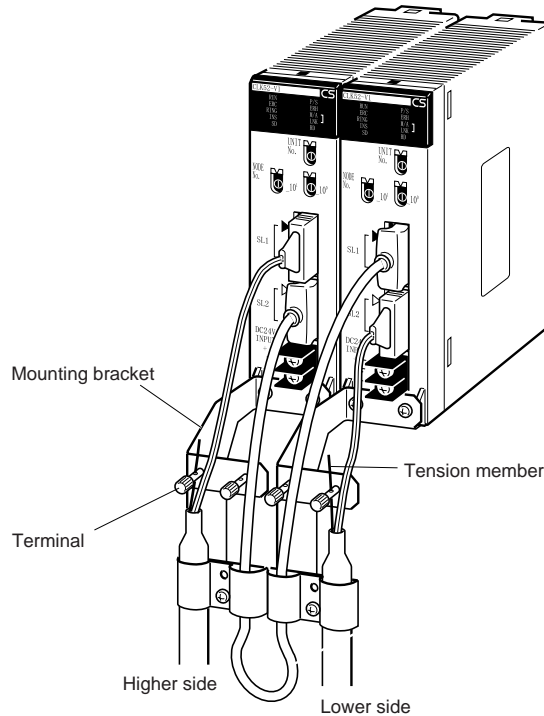

- Insert the connectors completely and always check that the connectors are locked before starting operation.
- If a connector becomes disconnected while in token-bus mode, the node will be unable to communicate with other nodes in that part of the network. The network will be divided into two and communications with the remaining nodes will be unreliable. Be sure not to remove connectors during communications.

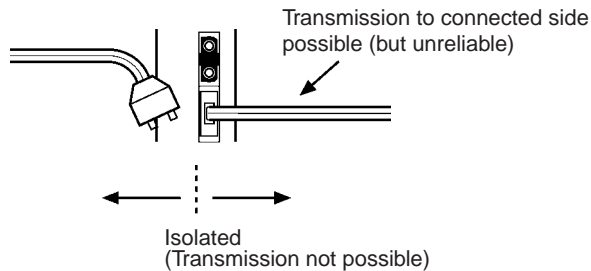

Even in token-ring mode, the network will be broken and communications may be disrupted if disconnections occur at two or more places. Be sure not to allow connectors to be disconnected during communications.

- Do not pull on the Optical Fiber Cable too forcefully. The maximum tension that can be applied to the cord is 10 kg and the maximum tension that can be applied to the cable is 50 kg.

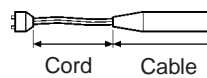

- Do not bend the cable too sharply. The minimum radius for bends is 10 cm.

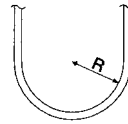

- To prevent the Optical Fiber Cable from being pulled too forcefully, always use the cable securing bracket and provide space below the Unit as shown in the following diagram. Do not exceed the maximum tension for the cord and cable:

Cord: 0 kg (Do not apply any tension.)

Cable: 5 kg

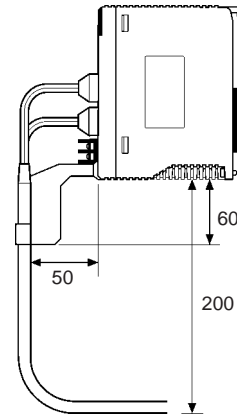
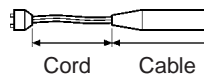

- Do not place objects on top of the Optical Fiber Cable. The maximum pressure that can be placed on the cord and cable is as follows:

Cord: 30 kg/10 cm

Cable: 50 kg/10 cm

- Inspect the connector before installing it.

3-3-5 Connecting Optical Fiber Cable to Connectors for GI Cable

A special connector (ST connector) is used to connect the GI Optical Fiber Cable to the Controller Link Unit.

Connect the GI Optical Fiber Cables to the nodes in order from higher to lower nodes. (When a ring topography is being used, connect the last node to the first node, too.)

Observe the following precautions when connecting the Optical Fiber Cables.

- Always turn OFF the PLC power supply before connecting Optical Fiber Cables.
- Special tools and skills are required to attach Optical Fiber Cables to the connectors. The cable may disconnect from the connector if the proper tools and methods are not used during cable assembly.

Connection Procedure

Use the following procedure to connect Optical Fiber Cables to a Unit.

1,2,3...

1. Attach the mounting bracket to the Unit with the provided screws.

- Attach the clamp to the mounting bracket so that it clamps the cable(s). Two cables can be attached at the same time.

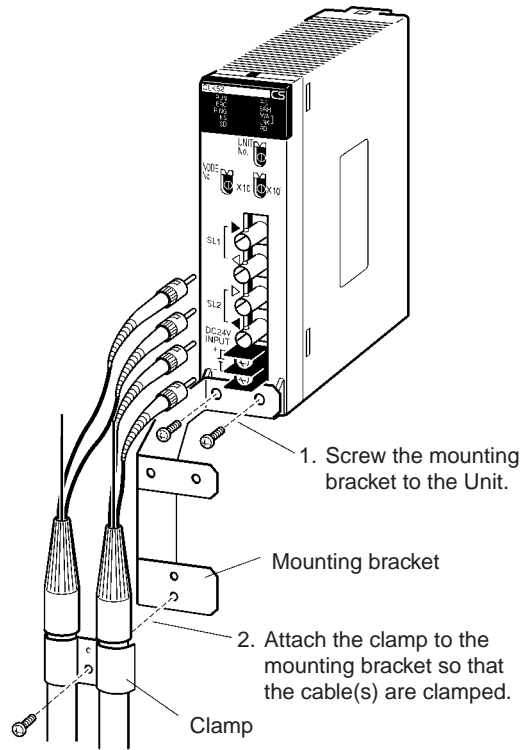

- Remove the Optical Connector Covers from the Unit's connectors shown in the following diagram if there are covers protecting the connectors. Remove the covers from the tips of the cables' ST connectors if there are covers protecting the ST connectors.

Optical Connector Cover

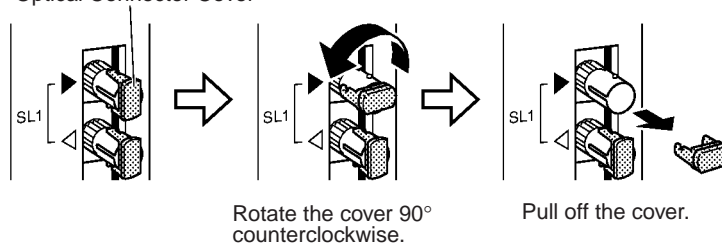

Note To replace the Optical Connector Cover, just reverse the steps shown in the diagram above.

- Turn the cable connector so that the tab in the connector faces left and aligns with the slot in the Unit's connector. Insert the cable connector fully into the Unit's optical connector. Press and turn the cable's connector clockwise to lock the connector in place.

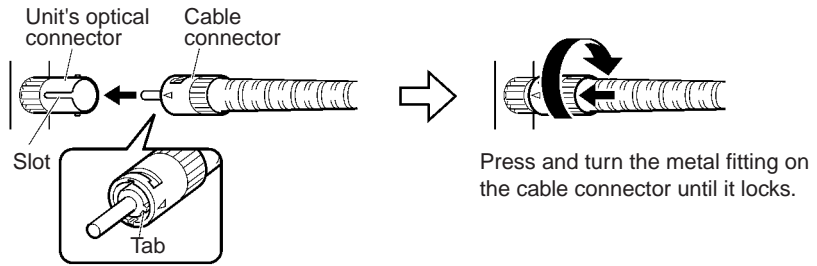

Align the tab in the cable connector with the slot in the Unit's connector and fully insert the cable connector.

Note To remove the connector, just reverse the steps shown in the diagram above. (Press and turn the cable connector's metal fitting counterclockwise to unlock the connector.)

5. After installing the Optical Fiber Cable, fix the tension member of the Optical Fiber Cable.
 - Insert the connectors completely and always check that the connectors are locked before starting operation.
 - If a connector becomes disconnected while in token-bus mode, the node will be unable to communicate with other nodes in that part of the network. The network will be divided into two and communications with the remaining nodes will be unreliable. Be sure not to remove connectors during communications.

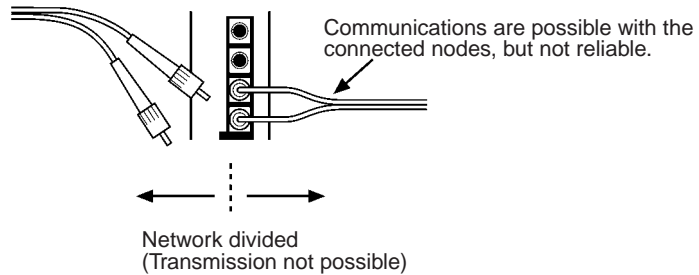

Even in token-ring mode, the network will be divided and communications may be disrupted if disconnections occur at two or more places. Be sure not to allow connectors to be disconnected during communications.

When installing Optical Fiber Cables, be sure to stay within the specifications (e.g., tensile strength, bending, lateral pressure) for the cables used.

3-3-6 Connecting Backup Power Supply Cables

Attach crimp terminals to the power supply cable when connecting the backup power supply to the Controller Link Unit.

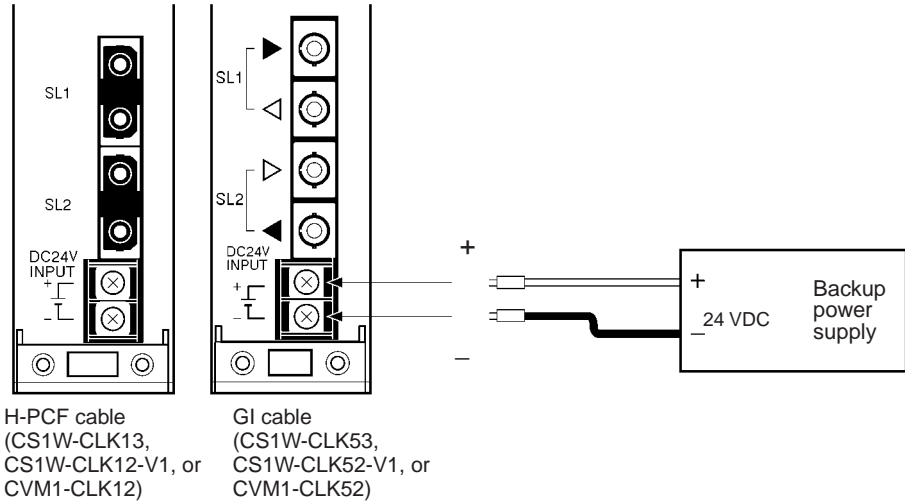

Crimp Terminals

Use M3 crimp terminals, as illustrated below.

H-PCF cable (CS1W-CLK13, CS1W-CLK12-V1, or CVM1-CLK12)



GI cable (CS1W-CLK53, CS1W-CLK52-V1, or CVM1-CLK52)



- Note**
1. Always turn OFF the power to the PLC and the backup power supply before connecting the backup power supply cables.
 2. Separate the backup power supply wires from other power lines and high-voltage lines to prevent noise.
 3. Always use a crimp terminal for wiring. Do not connect a wire that has only been twisted directly to a terminal block.
 4. For a higher degree of safety, it is recommended that a round crimp terminal is used.
 5. When mounting the crimp terminal, always use the appropriate tools for each crimp terminal and follow the appropriate installation procedures. Contact the crimp terminal manufacturer for details on the appropriate tools and procedures. Failure to use the appropriate tools and procedures could cause cables to break.
 6. Measure the length of peeled cable during installation according to the crimp terminal used and make sure that the peeled length is not too long. Cover the compressed section of the crimp terminal and cable with vinyl tape or heat-shrinking tube.
 7. Be sure not to reverse the power supply polarity.
 8. Tighten the screws on the terminal block firmly. The correct tightening torque is 0.5 N·m. If the screws are too loose, short-circuit, malfunction or burning may result.
 9. Do not pull backup power supply cables with excessive force.
 10. Do not bend backup power supply cables.
 11. Do not place any object on top of backup power supply cables.
 12. Supply power only after checking the wiring thoroughly.

SECTION 4

Preparations for Communications

This section describes the settings required for starting communications. These basic settings are required both for data links and the message service. Carry out the settings described here before turning ON power to the Controller Link Unit.

4-1	CS-series Optical Ring Controller Link Units	76
4-1-1	Overview	76
4-1-2	Setting the Unit Number	77
4-1-3	Setting the Node Addresses	78
4-1-4	Setting the Transmission Path Format	79
4-2	CVM1 and CV-series Optical Ring Controller Link Units	79
4-2-1	Overview	80
4-2-2	Setting the Unit Number	81
4-2-3	Setting the Node Address.	82
4-2-4	Setting the Transmission Path Format	82
4-2-5	Creating I/O Tables	83

4-1 CS-series Optical Ring Controller Link Units

Before starting communications, the following settings are required for an Optical Ring Controller Link Unit (H-PCF cable or GI cable) used with a CS-series PLC.

Item	Setting location	Page
Unit number	Unit number switch	77
Node address	Node address switches	78
Duplex settings (when using Communications Units in duplex operation)	PLC Setup	207
Transmission path format	Software switch	79

For details on duplex settings, refer to 8-3 Procedure for Using Duplex Units.

4-1-1 Overview

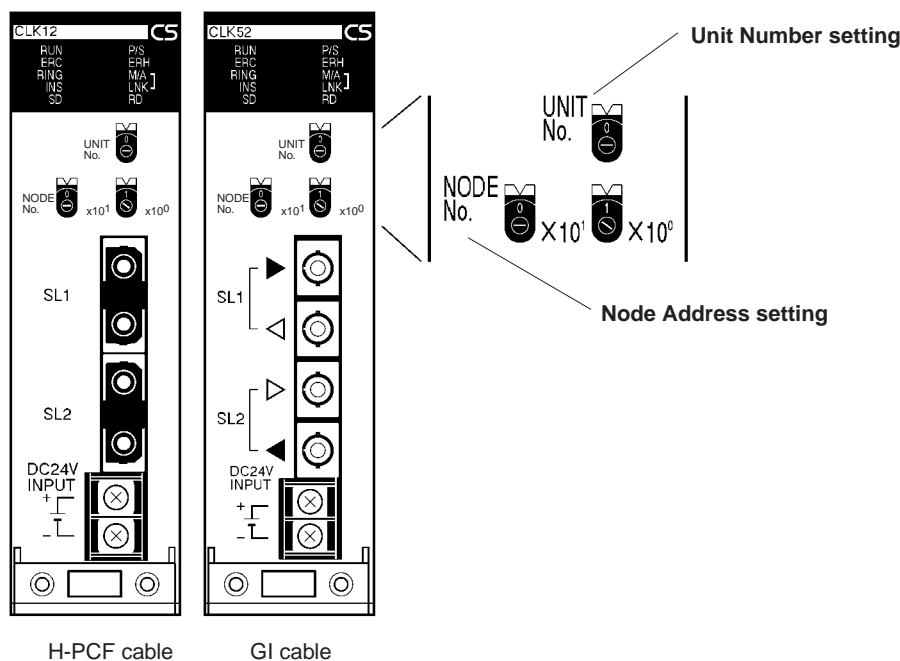

Unit Number

Setting range	Nodes
0 to F (default is 0)	All nodes in the Network

Node Address

Setting range	Nodes
01 to 62 (default is 01) (See note.)	All nodes in the Network

Note With the token-bus method, the maximum number of nodes in an Optical Bus System (i.e., model numbers ending in CLK11) with nodes is 32 (node addresses 1 to 32).

Duplex Settings for Communications Units (PLC Setup)

Refer to 8-3 Procedure for Using Duplex Units.

Transmission Path Format Setting (Software Switch)

Setting range	Nodes
Token-ring mode Token-bus mode	All nodes in the Network

Software switch (DM30000 + 100 x unit number)

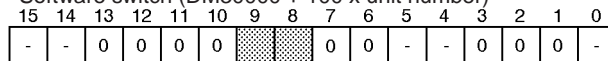

0: Always set to 0.
-: Other settings.

Transmission path setting

Transmission Path

Bit		Setting contents
9	8	
0	0	Token-ring mode
0	1	
1	0	
1	1	Token-bus mode

4-1-2 Setting the Unit Number

Set the unit number for each Unit using the rotary switches on the front of the Unit. When using Controller Link Units in duplex operation, set the same unit number for each active/standby pair of Units. The unit number is used to identify a CPU Bus Unit in the PLC. Any unit number can be set between 0 and F in hexadecimal (00 to 15 in decimal).



Note: The factory default settings are shown above.

Item	Specifications
Setting method	Single-digit hexadecimal
Setting range	0 to F (decimal 00 to 15, default is 0)
Node	All nodes in the Network

Set the node address using a small flat-blade screwdriver, being careful not to damage the rotary switches.

- Note**
1. Always turn OFF the PLC's power before setting the unit number.
 2. When setting a Unit for the first time or changing the existing setting, create a I/O table in the PLC's CPU Unit.
 3. If there are no Units used in duplex operation, do not set the same unit number twice within the same PLC. An error will occur if the same unit number is set for two different Units, and the CPU Unit will not be able to recognize the Units. If there are Units used in duplex operation, they will be recognized when the duplex settings have are made and the I/O tables recreated.
 4. When there are Controller Link Units used in duplex operation, if different unit numbers are set for an active/standby pair of Units, they will not be recognized as a pair, and will not operate properly.
 5. When the Unit is recognized by the PLC's CPU Unit, "Controller Link Unit (NS)" will be shown in the I/O table displayed at the CX-Programmer.
 6. The default setting is "0."
 7. The unit number determines the DM parameter area used by the Controller Link Unit in PLC memory.

4-1-3 Setting the Node Addresses

Set the node addresses of each Unit on the network using the rotary switches on the front of the Unit. When using Controller Link Units in duplex operation, set the same node address for each active/standby pair of Units. The node address is used to identify each node in the Network, and can be set to any number between 01 and 62.

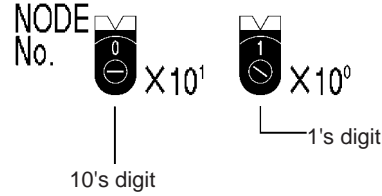

Note: The default settings are shown above.

Item	Specifications
Setting method	2-digit decimal
Setting range	01 to 62 (default: 01)
Node	All nodes in the Network.

Set the node address using a small flat-blade screwdriver, being careful not to damage the rotary switches.

- Note**
- When using Controller Link Units in duplex operation, be sure to set the same node address for each active/standby pair of Units. If a different node address is set, the Duplex Communications Unit Verification Error Flag (A26112) will turn ON and an I/O table generation error will occur. It will not be possible to create I/O tables using the Programming Device. At the same time, a Duplex Communications Setting Error Flag will turn ON (A43500 to A43515) will turn ON. (Bits 00 to 15 correspond to unit numbers 0 to 15.)
 - Always turn OFF the PLC's power before setting the node address.
 - If there are no Units used in duplex operation, do not set the same node address twice within the same network. A node address duplication error will occur if the same address is set for two different nodes. The ERC indicator on the front of the Unit will light (Communications Error Flag) and either communications will stop, or the INS indicator will not light and the node will be unable to participate in the network.
 - If there are Units used in duplex operation, the active Unit will enter the network when the duplex settings have are made and the I/O tables recreated.
 - The send sequence for the data link areas is determined according to the sequence of node addresses for automatically set data links.
 - Assign node addresses consecutively beginning from 01 whenever possible to minimize network construction time.
 - If there are Units used in duplex operation, the maximum number of actual nodes allowable in the network will decrease by the number of standby Units. There will be no effect, however, on the node address setting range.

4-1-4 Setting the Transmission Path Format

The transmission path format is set by a software switch allocated in the CPU Unit's DM parameter area. The same setting must be made for all nodes in the network. Select either token-ring mode or token-bus mode by using a PLC Programming Device (i.e., Programming Console or CX-Programmer) to set values for bits 9 and 8 in the software switch shown below.

When the transmission path format is changed, the change will not go into effect until the PLC's power is turned OFF and ON again or the Unit is restarted.

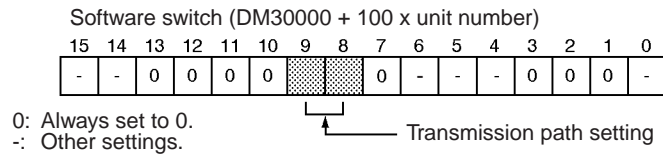

Transmission Path

Bit		Setting contents
9	8	
0	0	Token-ring mode
0	1	
1	0	
1	1	Token-bus mode

- Note**
1. Set the transmission path format before connecting the Controller Link communications cable.
 2. Make the same setting for all the nodes in the network. The network will not operate normally if the settings are different.
 3. Set the token-ring mode for ring connection, and the token-bus mode for daisy-chain connection. The network will not operate normally if the actual configuration is different from the transmission path format setting. If, for example, the actual configuration is daisy-chain while the transmission path format setting is for token-ring mode, it will be determined that the network is broken somewhere. (Even if this occurs, data communications will be started up.) The network will also not operate normally if the actual configuration is ring connection while the transmission path format setting is for token-bus mode.
 4. In CS1D Systems where Units are used in duplex operation or are replaced online, set the transmission path format to token-ring mode. This will stop the network from splitting when there is an active/standby switchover resulting from a Controller Link Unit error or a Unit is replaced online.
 5. The transmission path format for an Optical Bus System (CLK11) is always token-bus mode. When used in combination with Optical Bus Controller Link Units, therefore, CLK12, CLK12-V1, or CLK13 Optical Ring Controller Link Units (H-PCF cable) must also be set for token-bus mode.

4-2 CVM1 and CV-series Optical Ring Controller Link Units

Before starting communications, the following settings are required for an Optical Ring Controller Link Unit (H-PCF cable or GI cable) used with a CVM1 or CV-series PLC.

Item	Switch	Page
Unit number	Unit number switch	81

Item	Switch	Page
Node address	Node address switch	82
Transmission path format	Software switch	82

4-2-1 Overview

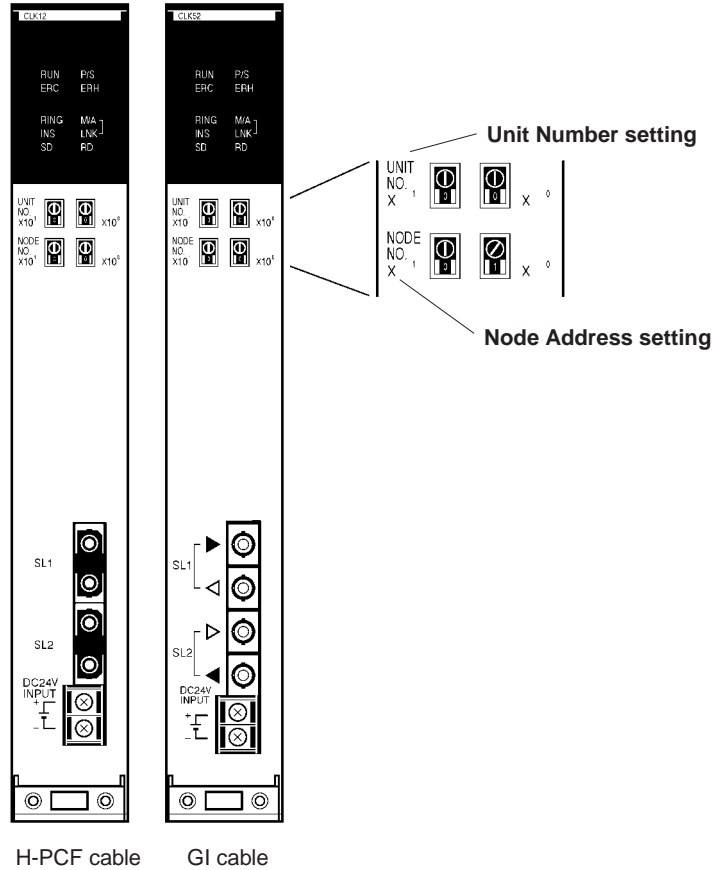

Unit Number

Setting range	Nodes
00 to 15 (default is 00)	All nodes in the Network

Node Address

Setting range	Nodes
01 to 62 (default is 01) (see note)	All nodes in the Network

- Note**
1. CX-Net in CX-Programmer can be used in systems with up to 32 nodes (node addresses 1 to 32). Use Controller Link Support Software (Ver. 2.00 or later) for systems with up to 62 nodes (node addresses 1 to 62).
 2. With the token-bus method, the maximum number of nodes in an Optical Bus System (i.e., model numbers ending in CLK11) with nodes is 32 (node addresses 1 to 32).

Transmission Path Format Setting (Software Switch)

Setting range	Nodes
Token-ring mode Token-bus mode	All nodes in the Network

Software switch (DM30000 + 100 x unit number)

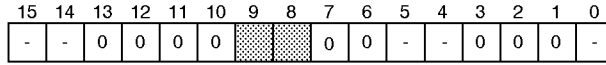

0: Always set to 0.
-: Other settings.

Transmission Path

Bit		Setting contents
9	8	
0	0	Token-ring mode
0	1	
1	0	
1	1	Token-bus mode

4-2-2 Setting the Unit Number

Set the unit number for each Unit using the rotary switches on the front of the Unit. The unit number is used to identify a CPU Bus Unit in the PLC. Any unit number can be set between 00 and 15.

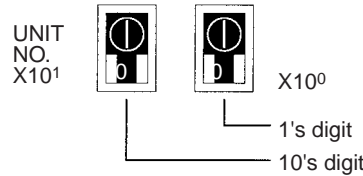

Note: The default settings are shown above.

Item	Specifications
Setting method	2-digit decimal
Setting range	00 to 15 (default is 00)
Node	All nodes in the Network

Set the node address using a small flat-blade screwdriver, being careful not to damage the rotary switches.

- Note**
1. Always turn OFF the PLC's power before setting the unit number.
 2. When setting a Unit for the first time or changing the existing setting, create a I/O table in the PLC's CPU Unit.
 3. Do not set the same unit number twice within the same PLC. An error will occur if the same unit number is set for two different Units, and the CPU Unit will not be able to recognize the Units.
 4. When the Unit is recognized by the CPU Unit, "Controller Link Unit (NS)" will be shown in the I/O table displayed at the CX-Programmer.
 5. The default setting is "00."
 6. The unit number determines the DM parameter area used by the Controller Link Unit in PLC memory.

4-2-3 Setting the Node Address

Set the node address of each Unit in the network using the rotary switches on the front of the Unit. The node address is used to identify each node in the Network.

The node address can be set to any value between 01 and 62.

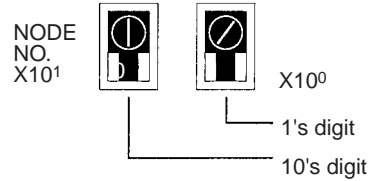

Note: The default settings are shown above.

Item	Specifications
Setting method	2-digit decimal
Setting range	01 to 62 (default is 01)
Node	All nodes in the Network

Set the node address using a small flat-blade screwdriver, being careful not to damage the rotary switches.

- Note**
1. Always turn OFF the PLC's power before setting the node address.
 2. Do not set the same node address twice within the same network. A node address duplication error will occur if the same address is set for two different nodes. The ERC indicator on the front of the Unit will light (Communications Error Flag) and either communications will stop, or the INS indicator will not light and the node will be unable to participate in the network.
 3. The send sequence for the data link areas is determined according to the sequence of node addresses for automatically set data links.
 4. Assign node addresses consecutively beginning from 01 whenever possible to minimize network construction time.

4-2-4 Setting the Transmission Path Format

The transmission path format is set by a software switch allocated in the CPU Unit's DM parameter area (the CPU Bus Unit Area). The same setting must be made for all nodes in the network. Select either token-ring mode or token-bus mode by using a PLC Programming Device (i.e., Programming Console or CX-Programmer) to set values for bits 9 and 8 in the software switch shown below.

When the transmission path format is changed, the change will not go into effect until the PLC's power is turned OFF and ON again or the Unit is restarted.

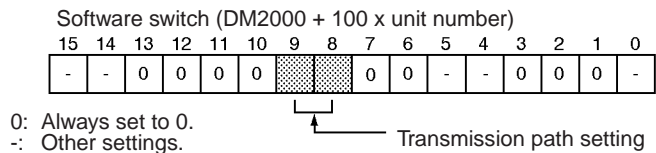

Transmission Path

Bit		Setting contents
9	8	
0	0	Token-ring mode
0	1	
1	0	
1	1	Token-bus mode

- Note**
1. Set the transmission path format before connecting the Controller Link communications cable.
 2. Make the same setting for all the nodes in the network. The network will not operate normally if the settings are different.
 3. Set the token-ring mode for ring connection, and the token-bus mode for daisy-chain connection. The network will not operate normally if the actual configuration is different from the transmission path format setting. If, for example, the actual configuration is daisy-chain while the transmission path format setting is for token-ring mode, it will be determined that the network is broken somewhere. (Even if this occurs, data communications will be started up.) The network will also not operate normally if the actual configuration is ring connection while the transmission path format setting is for token-bus mode.

4-2-5 Creating I/O Tables

I/O tables are created for CVM1 and CV-series PLCs using a Programming Device (Programming Console or CX-Programmer).

When using CX-Programmer, display the I/O Table Window and select *Options – I/O Table Creation*. The type of Units mounted and the mounting position will be written to the CPU Unit as a registration I/O table.

For details on creating I/O tables, refer to the operation manual for the Programming Device used.

SECTION 5

Data Links

This section describes how to use data links in a Controller Link Network. Refer to *Section 2 Basic Procedures* for an outline of data link application.

5-1	What Are Data Links?	86
5-1-1	Data Link Specifications	92
5-1-2	Differences Between Manual and Automatic Setting	93
5-2	Setting Data Links	94
5-2-1	Selecting Manual or Automatic Setting	94
5-2-2	Manual Setting	95
5-2-3	Manual Setting Examples	100
5-2-4	Automatic Setting: Select All	107
5-2-5	Automatic Setting Example	125
5-3	Starting and Stopping Data Links.	127
5-3-1	Using a Programming Device or the User Program.	128
5-3-2	Using the Controller Link Support Software (Ver. 2.00 or Later) and CX-Programmer	129
5-3-3	Using FINS Commands	129
5-4	Checking Data Link Status	130
5-4-1	LED Indicators	130
5-4-2	Data Link Status Area	130
5-4-3	Data Link Status Storage Format	134
5-4-4	Checking by Manipulating Bit/Word Status	135
5-4-5	Error Detection Program Example	135

5-1 What Are Data Links?

Data links automatically exchange data in the preset areas between nodes (PLCs and/or computers) on one network. Data links can be freely created for CS-series, CVM1, and CV-series PLCs, and IBM PC/AT or compatible computers (in token-bus mode only).

CS-series Controller Link Unit Functions by Model

Item	Model number	CS1W-CLK12-V1 CS1W-CLK52-V1	
	CS1W-CLK13 CS1W-CLK53	Unit version 1.2	Pre-Ver. 1.2
Maximum number of send/receive data link area (for send or receive data link area that can be created for one PLC node)	20,000 words max.		12,000 words max.
Number of send words per node (total of area 1 and area 2)	4,000 words max. (optional setting only)	1,000 words max.	
Data Link Area	The same area can be allocated for area 1 and area 2.	The same area cannot be allocated for area 1 and area 2.	

- Note**
1. Use the CX-Net in CX-Programmer version 5.0 or higher to set a data links with more than 12,000 data link send/receive words, or to set data links allocating the same area for areas 1 and 2.
 2. Use the CX-Integrator to set data link tables with more than 1,000 send words per node. For information on checking the CX-Integrator version, refer to *Checking the CX-Integrator Data Link Setting Tool Version* on page viii.

Two data link areas, Area 1 and Area 2, can be set for each node. Data links can be set in either of the following ways.

- Data link areas can be manually set by inputting data link tables through Support Software. Data link tables are created to define the data links. These tables enable free allocation of data link areas.
- Data links can be set automatically from a Programming Device. With automatically set data links, all link areas are the same size.

Both automatic setting and manual setting cannot be used together in the same network. The following rules apply to these two methods of setting data links.

- Data links are enabled concurrently for Area 1 and Area 2.
- Separate settings (data link start words and send area size) are made in Area 1 and Area 2. The sequences of send and receive words are the same in Area 1 and Area 2.
- Not all nodes must participate in the data links.

Manually Setting Data Links

Example 1: The order of send and receive nodes is free.

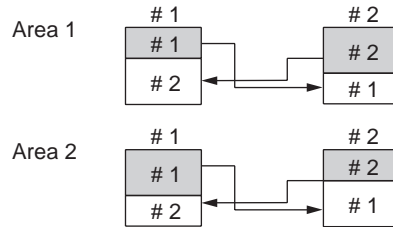

Example 2: Some nodes can send data without receiving data.

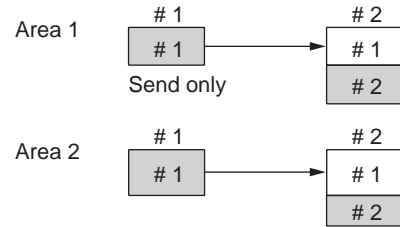

Example 3: Some nodes can receive data without sending data.

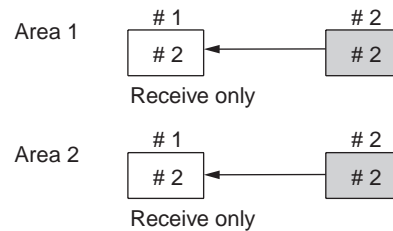

Example 4: A node can receive only a specified number of words from the beginning of an area.

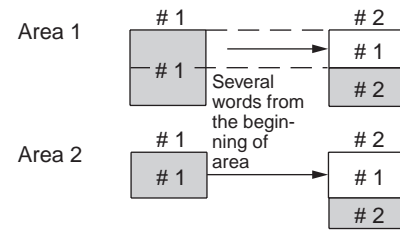

Manually set data links are used to create flexible data links that meet the needs of the individual system.

- Data links are set in the Controller Link Unit or Board of each node using the Support Software.
- Area 1 and Area 2 can be selected from PLC memory areas, including the DM Area and EM Area.
- A send area and its size can be allocated freely for each node.
- The sequence of receive nodes can be changed.
- Nodes can be set that only send or only receive data.
- Only part of send data can be received and an offset can be used to specify the beginning of the desired part.

Manual Setting Options

The following options can be set when manually setting data links.

Offsets

Data of only the specified number of words can be received starting from the specified word position. The starting word is set as an offset from the beginning of the send data. The following is an example.

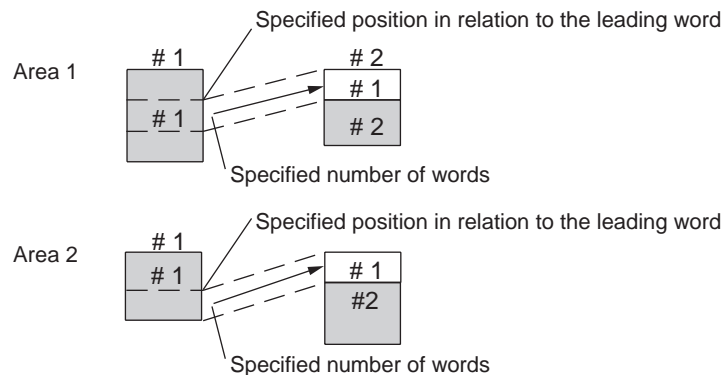

Easy Setting

The send data areas of all nodes can be set to the same size (same as for automatic setting described next).

Automatically Setting Data Links with Equality Layout

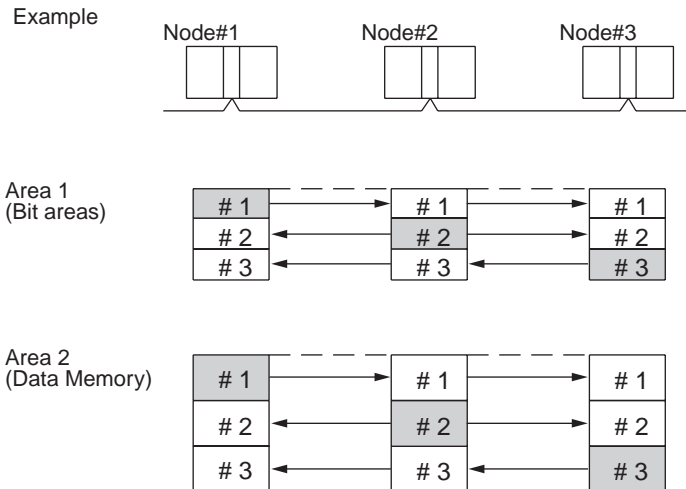

Automatic setting can be used to create simple data links.

- Using a Programming Device (such as a Programming Console), set the automatic data link mode in the DM parameter area of the startup node.
- Area 1 can be selected from bit areas (i.e., CIO and LR areas) and Area 2 can be selected from Data Memory.
- In areas 1 and 2 send areas for each node are of the same size.
- Send nodes are in the same ascending order as node numbers.
- It is not possible to receive only a part of send data.
- All nodes can be specified to either participate or not participate in the data link.
- The data link areas are exactly the same and common to all nodes participating in the data links.

Note The Controller Link Support Software contains a function called “Easy Setting” that can be used within the manual data link mode to register the same data links as automatic setting. The “Easy Setting” can be used first, and then the send size of each node and other settings can be changed as required.

Automatically Setting Data Links with 1:N Allocations

This method is used to simplify the setting of 1:N allocation data links between master and slave nodes.

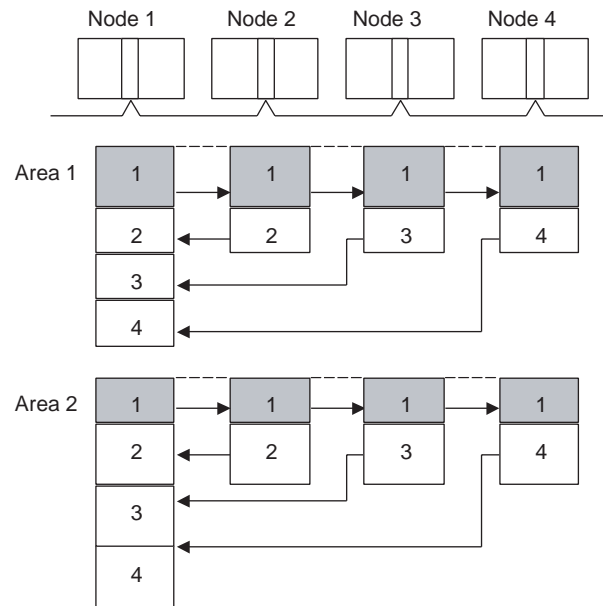

- There are three types of 1:N allocations.
- Programming Devices (including Programming Consoles) are used to set the automatic data link mode in the DM parameters area of the CPU Unit used as the startup node.
- Node 1 is the master node.
- Areas 1 and 2 can be set in bit-access areas or the DM Area.
- The send area sizes for the master and slave nodes are the same for each area.
- Send nodes are in the same ascending order as node numbers.
- Each node can be specified to either participate or not participate in the data links.
- The data link areas (data link start words) are common to all nodes participating in the data links.

Note 1. Automatic data link creation with 1:N allocations can only be used with the following Controller Link Units and Support Boards:

Type	Model
Optical Ring Systems	CS1W-CLK13 and CS1W-CLK12-V1 (for CS Series) (See note a.)
	CS1W-CLK53 and CS1W-CLK52-V1 (for CS Series) (See note a.)
	3G8F7-CLK13 and 3G8F7-CLK12-EV1 (for PCI bus)
	3G8F7-CLK53 and 3G8F7-CLK52-EV1 (for PCI bus)

Note (a) For Pre-Ver. 1.2 CS1W-CLK12-V1 or CS1W-CLK52-V1 Controller Link Units, use those from lot number 0306□□_□□□□ or later (manufactured after May 2003). Earlier models do not support automatic data link creation with 1:N allocations.

Lot Number notation: The first two digits refer to the year (last two digits of years from 2000 onwards), and the following two digits indicate the month (01 to 12, for January to December, respectively). (The last 7 digits are not relevant.)

2. Controller Link Units and Support Boards other than those listed above cannot participate in 1:N allocation data links. They can, however, join the network if the parameter for specifying data link participation status in the DM parameters area is set so that they do not participate in the data links.
3. A 3G8F7-CLK13/12-EV1 or 3G8F7-CLK53/52-EV1 Controller Link Support Board can be used in automatic data link creation with 1:N allocations, but it cannot be used as the startup node. Use a CS1W-CLK12/52-V1 (lot number 0306□□_□□□□ or later), CS1W-CLK13, or CS1W-CLK53 Controller Link Unit on the same network as the startup node. Refer to note 1 for details on lot number notation.
4. For automatic data link creation with 1:N allocations, use the CX-Net in CX Programmer version 3.2 or later.

Using Offsets

For automatically set data links, all of the send words transmitted by a node are received by other nodes with no change in size. For manually set data links, the size of a receive area can be restricted by specifying a number of words from the beginning word of the words sent by another node.

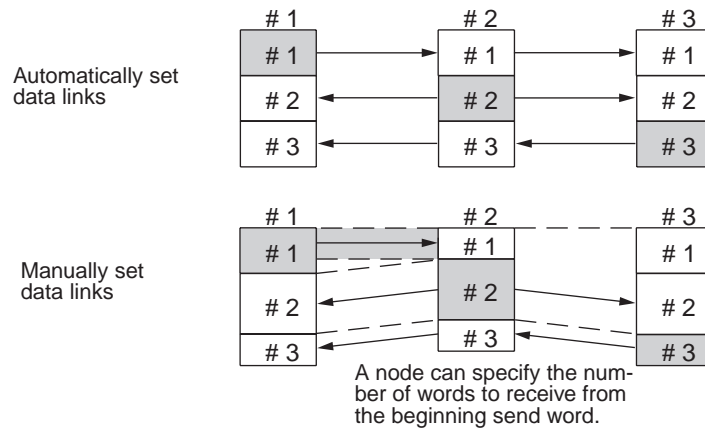

However, the above system does not guarantee that only the desired words will be received and therefore the receive node may receive unnecessary data.

Offsetting enables specification of a more specific range of receive data by indicating both the number of words and the starting word position from the beginning of the area. The offset refers to the starting word position counted from the beginning of the area.

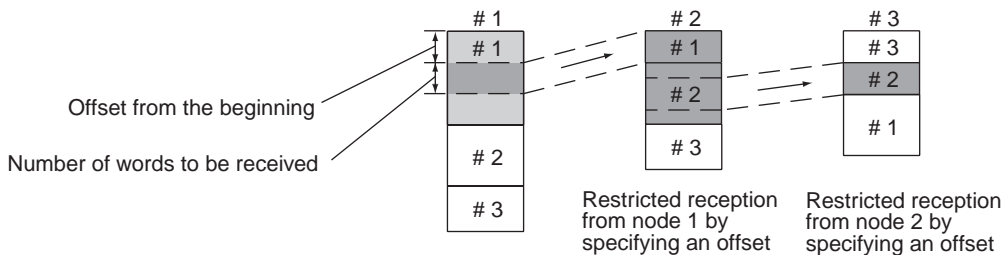

Offsetting Image

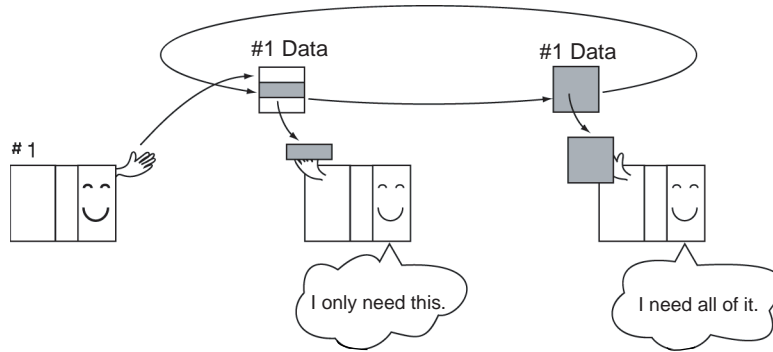

Application Example of Using Offsets

In the following example, the send data from node 1 is split into three parts and each part is received by a different node, i.e., each of the other nodes receives only part of the send data from node 1. This enables effective use of data link memory areas without wasting space. In this way, a type of message service (i.e., specific data to a specific node) can be achieved through data links.

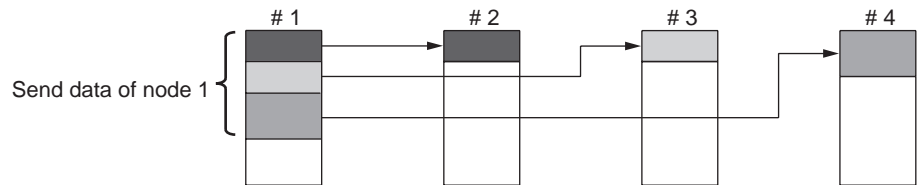

Note The following table shows the status of the data link refresh area when a node that is registered in the data link table generates a communications error.

Communications error type	Data link area
A node is isolated from the network while a data link is running.	Data received immediately prior to the error continues to be refreshed in the data link areas of the relevant nodes.
A node does not join the network after the data links start.	Zero (0) data continues to be refreshed in the data link areas of the relevant nodes.

5-1-1 Data Link Specifications

Item	Description	
Number of data link nodes	62 max., 2 min. (See note 1 and 2.)	
Number of data link words	Number of send words per node (total for area 1 and 2): 4,000 words max. (model numbers ending in CLK13 and CLK53) 1,000 words max. (all other Units and Boards) Number of send/receive words per node (total of Area 1 and Area 2): CS: 12,000 max. (pre-Ver. 1.2) 20,000 max. (unit Ver. 1.2 or later) CVM1/CV: 8,000 max. IBM or compatible: Manual setting: 62,000 max. (See note 1.) Automatic setting: 8,000 max.	
Allocation of data link areas	Manual setting	Area 1, 2: Bit area (CIO and LR Areas) Data Memory (DM and EM Areas) Unit Ver. 1.2 or later: Area 1 and Area 2 can be set in the same memory area. Pre-Ver. 1.2: Area 1 and Area 2 cannot be set in the same memory area.
	Automatic setting equality layout	Area 1: CIO or LR Area Area 2: Data Memory (DM and EM Areas)
	Automatic setting 1:N allocations	Area 1, 2: Bit area (CIO and LR Areas) Data Memory (DM and EM Areas)

- Note** 1. In systems that combine Optical Bus Controller Link Units/Boards (model numbers ending with CLK11) with other Units/Boards, the max. number of nodes and words are as follows:

Method	Specification
Manual	Optical Bus Units/Boards: Up to 32 nodes (with node addresses 1 to 32) can be data linked and the max. number of data link words is 32,000 words/node.
Automatic	All Units/Boards: Up to 32 nodes (with node addresses 1 to 32) can be data linked and the max. number of data link words is 32,000 words/node.

2. If Controller Link Units are used in duplex operation, the maximum number of active nodes is equal to the following:
 62 – Number of standby Units

5-1-2 Differences Between Manual and Automatic Setting

Item	Manual setting	Automatic setting
Determination of nodes to be in a data link	Determined by setting data link tables.	Determined by the data link parameters set in the data link startup node (the node used to start the data links).
Data link settings	Set in data link tables that are set in the nodes to participate in data links.	Determined by the data link parameters set in the data link startup node (the node used to start the data links).
Data link areas 1 and 2	In each node, Area 1 and Area 2 are selected from bit areas (CIO and LR Areas) and Data Memory (DM and EM Areas). However, areas 1 and 2 cannot be set in the same memory area.	Area 1 is selected from bit areas (CIO and LR Areas) and Area 2 is selected from Data Memory (DM and EM Areas).
Refresh starting word	Can be set freely in each node. (See note 1.)	Can be set freely. (See note a))
Data link status area	Selected from bit areas (CIO and LR Areas) and Data Memory (DM and EM Areas) in each node.	Selected from bit areas (CIO Area).
Refresh sequence	Can be set in each node freely.	Node addresses are in ascending order.
Data reception	It is possible to set in each node whether the entire data or a part of the data sent from another node is received. It is also possible to not receive the data sent from a specific node. (See note 2.)	The entire data sent from each node that is participating in the data link is received.
Data transmission	The send sizes can be set freely in each node. It is also possible for certain node not to send data. (See note 2.)	In Area 1 and Area 2, data send sizes are the same in each node.

- Note**
- The following are true for computer nodes (i.e., computers with a Controller Link Support Board mounted).
 - The data link starting position is fixed.
 - Because areas such as bit areas and DM are not available, areas must be made available on the computer for linking.
 - Automatically set data links cannot be started from the Controller Link Support Board.
 - The Controller Link Support Board can participate in automatically set data links.
 - If data links are manually set, send/receive area can be selected in each node, allowing send/receive groups to be created within the network in Area 1 and Area 2, as shown below.

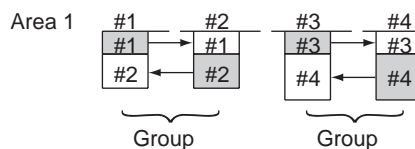

5-2 Setting Data Links

5-2-1 Selecting Manual or Automatic Setting

Specify either the manual or automatic data link mode in the following DM parameter area of the PLC's CPU Unit of the startup node, using a PLC Programming Device.

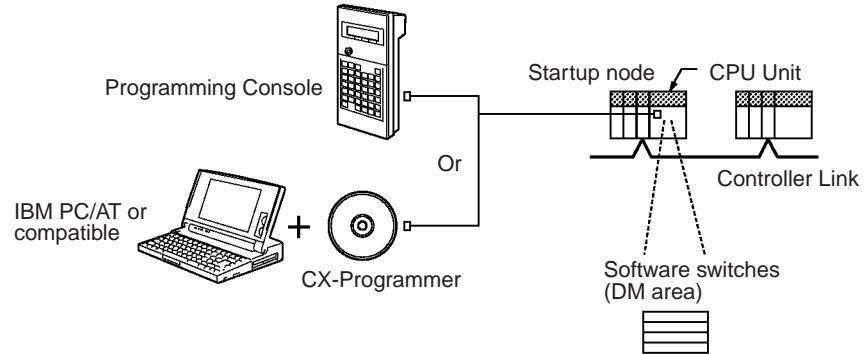

CS-series Startup Nodes

N: DM 30000 + 100 x Unit number of Controller Link Unit

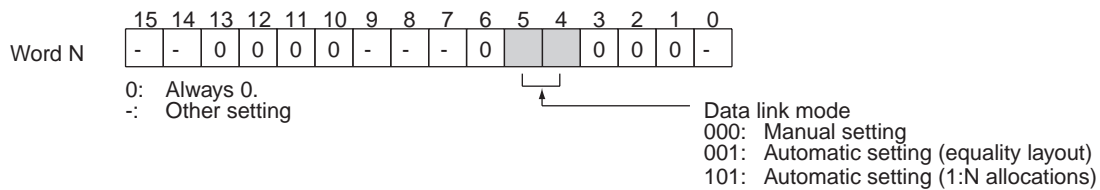

CVM1 and CV-series Startup Nodes

N: DM 2000 + 100 x unit number of Controller Link Unit

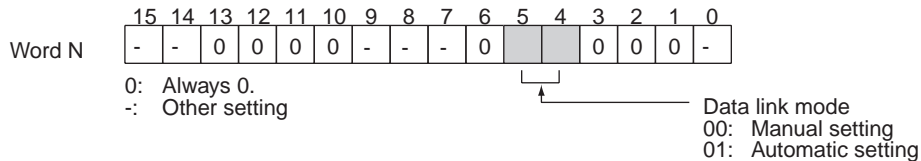

- Note**
1. The default data link mode is for manual setting (00), but check the setting from the Programming Device.
 2. A data link mode can be set in a data link startup node only. The data link mode setting is determined by the data link mode of the startup node even if the data link mode settings of the nodes participating in the data links are different from the settings in the startup node.
 3. In manual setting, a data link table must be set in the data link startup node and in automatic setting, automatic data link setting parameters must be set in the data link startup node. Data links will not be started unless the settings are correct.
 4. To prevent starting using incorrect data link modes or parameters, always be sure to confirm that the data link settings are correct in all startup nodes in the applicable network. Make sure that automatic setting and manual setting modes are not used together in the same network and that automatic settings with different parameters are not used.

5-2-2 Manual Setting

Transfer the data link tables that were created on the Controller Link Support Software (Ver. 2.00 or later) or CX-Net (in CX-Programmer) to the Controller Link Unit or the Controller Link Support Board (for IBM PC/AT or compatible computers).

The data link tables are transferred from a computer running the Controller Link Support Software (Ver. 2.00 or later). The computer can either be a node in the network or a computer attached as a Programming Device.

Transferring from a Programming Device

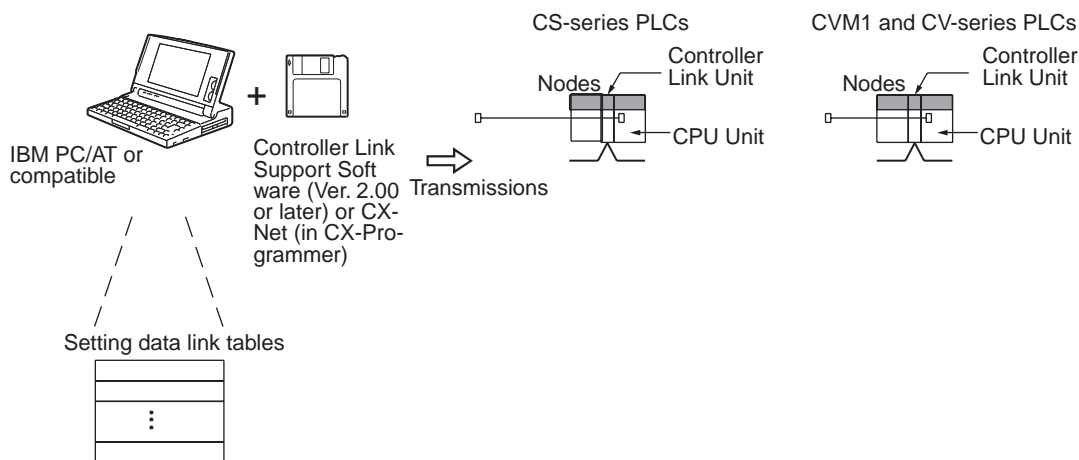

- Note**
1. When transferring data link tables to a CS-series PLC, set pin 1 of the DIP switch on the CPU Unit to "OFF." Otherwise, data link tables cannot be written normally.
 2. When transferring the data link tables to a CVM1 or CV-series PLC, set the System Protect Key switch on the CPU Unit to "NORMAL." Otherwise, data link tables cannot be written normally.
 3. The Controller Link Support Software (Ver. 2.00 or later) can be integrated into the SYSMAC Support Software. Refer to the *Controller Link Support Software Operation Manual (W308)* for details.

Transferring from a Computer Node

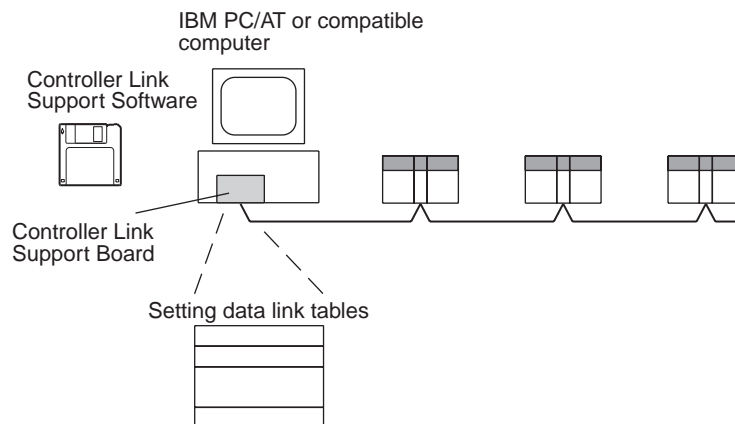

A data link table is created for each node using the Controller Link Support Software (Ver. 2.00). The data link tables contain all the settings required to create the data links.

- Note**
1. The following three methods can be used to start data links. (See p. 127.)
 - Using a software switch
 - Using the Controller Link Support Software or CX-Net (in CX-Programmer)
 - Using an FINS command
 2. To create data link tables using the Controller Link Support Software (Ver. 2.00), the network must have been constructed correctly. Set routing tables at each node as required. For details, refer to *7-4 Setting Routing Tables*.

Data Link Table Specifications

CS-series PLCs

Setting item	Setting range
PLC model	Set the model of the PLC's CPU Unit.
Nodes	1 to 62 (*1) Set the address of the refresh node. It cannot be set to a parameter exceeding the "maximum node address" of the network parameter. *1: With an Optical Bus System, data is received for only a maximum of 32 nodes (node addresses 1 to 32). When Optical Bus and Optical Ring Controller Link Units are used in combination, the maximum number of nodes will be 32 if the automatic setting is in effect. Likewise, the maximum number of nodes will be 32 (node addresses 1 to 32) when CX-Net in CX-Programmer is used as a Programming Device.
First data link status word	Set the first word to store data link status. An area of 31 words is used for 8-bit format and an area of 16 words is used for 4-bit format. CIO Area: CIO 001 to CIO 6128 (*1) LR Area: LR 00 to LR 184 (*2) DM Area: DM 0000 to DM 32752 EM Area: Banks 00 to 12, EM 0000 to EM 32752 *1: When CIO 000 is specified or when the default setting (-----) is left unchanged, the default first status word will be used. Refer to <i>5-4 Checking Data Link Status</i> for details. *2: When a word between LR 000 and LR 184 is specified, the data link area will be allocated between CIO 1000 and CIO 1184.

Setting item		Setting range
Area 1	Data link start word	<p>CIO Area: CIO 000 to CIO 6143 LR Area: LR 00 to LR 199 (*) DM Area: DM 0000 to DM 32767 EM Area: Banks 00 to 12, EM 0000 to EM 32767 Unit Ver. 1.2 or later: The same memory areas can be set for both Area 1 and Area 2. *: When a word between LR 000 and LR 199 is specified, the data link area will be allocated between CIO 1000 and CIO 1199.</p>
	Number of words	<p>Remote nodes: 0 to the number of source words Set the number of words to be received. Local node: CS1W-CLK13/53: 0 to 4,000 CS1W-CLK12/52-V1: 0 to 1,000 Set the number of words to be transmitted. The total number of words in area 1 and area 2 in each node must not exceed 1,000 (or 4,000 for the CS1W-CLK13 or CS1W-CLK53). The numbers of words in both Area 1 and Area 2 in each node must not be set to 0.</p>
	Offset	<p>Remote nodes: 0 to one less than number of source words Set the offset for the data to be received. Local node: Cannot be set. This setting is not required if an offset is not used.</p>
Area 2	Data link start word	<p>CIO Area: CIO 000 to CIO 6143 LR Area: LR 00 to LR 199 (*) DM Area: DM 0000 to DM 32767 EM Area: Banks 00 to 12, EM 0000 to EM 32767 (EM must be installed) Unit Ver. 1.2 or later: The same memory areas can be set for both Area 1 and Area 2. *: When a word between LR 000 and LR 199 is specified, the data link area will be allocated between CIO 1000 and CIO 1199.</p>
	Number of words	<p>Remote nodes: 0 to the number of source words Set the number of words to be received. Local node: CS1W-CLK13/53: 0 to 4,000 CS1W-CLK12/52-V1: 0 to 1,000 Set the number of words to be transmitted. The total number of words in area 1 and area 2 in each node must not exceed 1,000 (or 4,000 for the CS1W-CLK13 or CS1W-CLK53). The numbers of words in both Area 1 and Area 2 in each node must not be set to 0.</p>
	Offset	<p>Remote nodes: 0 to one less than number of source words Set the offset for the data to be received. Local node: Cannot be set. This setting is not required if an offset is not used.</p>

- Note**
1. The total number of words in data link send and receive areas must not exceed 20,000 per node when using Controller Link Units with unit Ver. 1.2 or later, or 12,000 words per node if using pre-Ver. 1.2 Controller Link Units.

2. The following values must be satisfied for each node for the data link Area 1 and Area 2 so that the final word in the data link does not go beyond the last word in the PLC memory area.

(Data link start word – 1) + (Total number of send/receive words in Area 1 or Area 2)

- ≤ 6143 (CIO Area)
- 199 (LR Area)
- 32767 (DM Area, EM Area)

3. Refer to the *Controller Link Support Boards Operation Manual (W307)* for information on the Controller Link Support Board.
4. If CX-Net detects an error during the data link table check, troubleshoot the error referring to *10-4 Troubleshooting Error Messages*.

CVM1 and CV-series PLCs

Setting item	Setting range
PLC model	Set the model of the PLC's CPU Unit.
Nodes	1 to 62 (*1) Set the address of the refresh nodes. It cannot be set to a parameter exceeding the "maximum node address" of the network parameter. *1: When Optical Bus and Optical Ring Controller Link Units are used in combination, the maximum number of nodes will be 32 if the automatic setting is in effect. Likewise, the maximum number of nodes will be 32 (node addresses 1 to 32) when CX-Net in CX-Programmer is used as a Programming Device.
First data link status word	Set the first word to store data link status. An area of 31 words is used for 8-bit format and an area of 16 words is used for 4-bit format. CIO Area: CIO 0001 to CIO 2540 (*1) LR Area: LR 000 to LR 184 (*2) DM Area: DM 0000 to DM 8176 (CV500/CVM1-CPU01) DM 0000 to DM 24560 (Other CPU Units) EM Area: Banks 00 to 07, EM 0000 to EM 32750 (EM must be installed) *1: When CIO 000 is specified or when the default setting (-----) is left unchanged, the default first status word will be used. Refer to <i>5-4 Checking Data Link Status</i> for details. *2: When a word between LR 000 and LR 184 is specified, the data link area will be allocated between CIO 1000 and CIO 1184.

Setting item		Setting range
Area 1	Data link start word	<p>CIO Area: CIO 0000 to CIO 2555 LR Area: LR 000 to LR 199 (*) DM Area: DM 0000 to DM 8191 (CV500/CVM1-CPU01) DM 0000 to DM 24575 (Other CPU Units) EM Area: Banks 00 to 07, EM 0000 to EM 32765 (EM must be installed)</p> <p>The same area cannot be set for both Area 1 and Area 2. Set different areas.</p> <p>*: When a word between LR 000 and LR 199 is specified, the data link area will be allocated between CIO 1000 and CIO 1199.</p>
	Number of words	<p>Remote nodes: 0 to the number of source words Set the number of words to be received.</p> <p>Local node: 0 to 1,000 Set the number of words to be transmitted.</p> <p>The total number of words in Area 1 and Area 2 in each node must not exceed 1,000.</p> <p>The numbers of words in both Area 1 and Area 2 in each node must not be set to 0.</p>
	Offset	<p>Remote nodes: 0 to one less than number of source words Set the offset for the data to be received.</p> <p>Local node: Cannot be set.</p> <p>This setting is not required if an offset is not used.</p>
Area 2	Data link start word	<p>CIO Area: CIO 0000 to CIO 2555 LR Area: LR 000 to LR 199 (*) DM Area: DM 0000 to DM 8191 (CV500/CVM1-CPU01) DM 0000 to DM 24575 (Other CPU Units) EM Area: Banks 00 to 07, EM 0000 to EM 32765 (EM must be installed)</p> <p>The same area cannot be set for both Area 1 and Area 2. Set different areas.</p> <p>*: When a word between LR 000 and LR 199 is specified, the data link area will be allocated between CIO 1000 and CIO 1199.</p>
	Number of words	<p>Remote nodes: 0 to the number of source words Set the number of words to be received.</p> <p>Local node: 0 to 1,000 Set the number of words to be transmitted.</p> <p>The total number of words in Area 1 and Area 2 in each node must not exceed 1,000.</p> <p>The numbers of words in both Area 1 and Area 2 in each node must not be set to 0.</p>
	Offset	<p>Remote nodes: 0 to one less than number of source words Set the offset for the data to be received.</p> <p>Local node: Cannot be set.</p> <p>This setting is not required if an offset is not used.</p>

- Note**
1. The total number of words in data link send and receive areas must not exceed 8,000 per node.
 2. The following values must be satisfied for each node for the data link Area 1 and Area 2 so that the final word in the data link does not go beyond the last word in the PLC memory area.

(Data link start word – 1) + (Total number of send/receive words in area)

- ≤ 2555 (CIO Area)
- 199 (LR Area)
- 8191 (DM Area for CV500/CVM1-CPU01)
- 24575 (DM Area for other CPU Units)
- 32765 (EM Area)

3. Refer to the *Controller Link Support Boards Operation Manual (W307)* for information on the Controller Link Support Board.
4. The total number of words in data link send and receive areas must not exceed 20,000 per node when using Controller Link Units with unit Ver. 1.2 or later, or 12,000 words per node if using pre-Ver. 1.2 Controller Link Units.

Precautions

- When data links are automatically created for networks containing CS-series PLCs, CVM1, and CV-series PLCs, the linkable area is restricted to the area of the CVM1, CV-series PLC because it is smaller than that of CS-series PLCs.

Example: DM Area

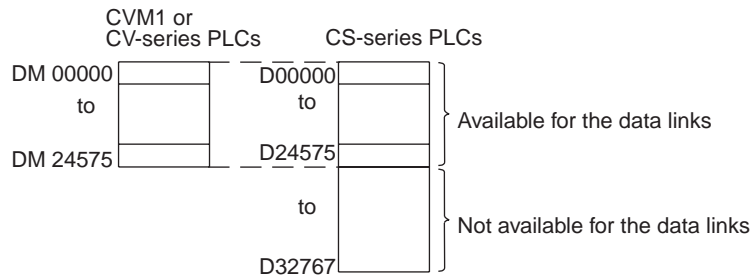

- The following limitations apply when Optical Bus (CLK11) and Optical Ring (H-PCF cable) (CLK12, CLK12-V1, or CLK13) Controller Link Units are used in combination.
 - The data that can be received by the Optical Bus Controller Link Units is limited to node addresses 1 to 32, and the data link status that is reflected is also limited to these node addresses.
 - When data links are set automatically, and an Optical Ring Controller Link Unit is used as the startup node, register the participating nodes within the range of node addresses 1 to 32. If a node address of 33 or higher is included, a data link table setting error will be generated at the Optical Ring Controller Link Unit.
 - When setting data links manually, the receiving nodes that are set in the Optical Bus Controller Link Unit data link table must be within the range of node addresses 1 to 32. If a node address of 33 or higher is included, a data link table setting error will be generated at the Optical Bus Controller Link Unit.

5-2-3 Manual Setting Examples

This section shows examples of manually creating data link tables on the Controller Link Support Software. Sample files containing the data link tables are provided on the installation disk for the Support Software and the CD-ROM disk provided with the Controller Link Support Boards.

SAMPLE1.CLK: Same Allocation to All Nodes

Data Link Area Structure

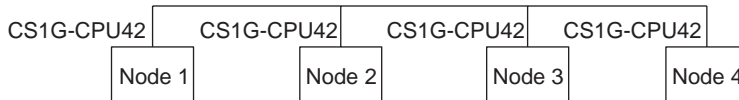

Data Link Areas

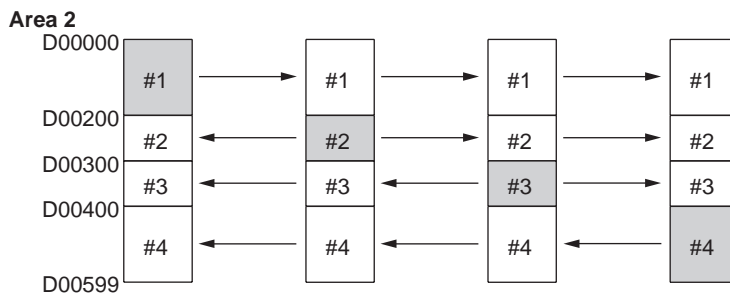
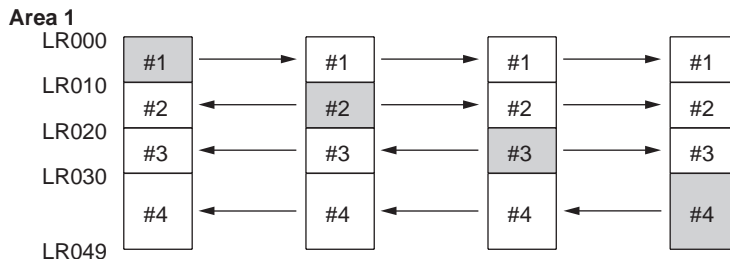

Device Information Settings

Device Info set				DataLink table			
Node	Model name	Node	Model name	Node	Model name	Node	Model name
01	CS1G-42	17		33		49	
02	CS1G-42	18		34		50	
03	CS1G-42	19		35		51	
04	CS1G-42	20		36		52	
05		21		37		53	
06		22		38		54	

Data Link Tables

Edit							DataLink table	
Node[01]		Pctype[CS1G-42]		Num of Nd [4]		Status Word[-----]		
Node	<Area1>	Link Start Word	Link Num Wd	Source Wd	<Area2>	Link Start Word	Link Num Wd	Source Wd
01	L00000	10	Send Area		D00000	200	Send Area	
02	L00010	10	L00010		D00200	100	D00200	
03	L00020	10	L00020		D00300	100	D00300	
04	L00030	20	L00030		D00400	200	D00400	

Set exactly the same table for nodes 2, 3, and 4. To do this, the copy function can be used to copy the data link table for node 1 to nodes 2, 3, and 4.

Checking the Data Link Tables

Check DataLink table

Node [] DataLink table

Node	error message	Node	error message

Check OK

1 menu 2 S menu 3 4 5 6 7 8 9 End

Transferring the Data Link Tables

```
[Controller Link->Computer]
Will transfer DataLink table.
Specify network address, node address
to transfer.
      Network address      :000

Node Dsgn Node Dsgn Node Dsgn Node Dsgn
01 YES
02 YES
03 YES
04 YES
```

Saving the Data Link Tables

```
[ Save DataLink table      ]
Input file name to save.
C:\CLK\SAMPLE1.CLK
```

SAMPLE2.CLK: Different Allocations to Each Node

Data links can be created so that one node does not receive from all other nodes or so that some nodes do not send or receive any data at all. In the following example, node 2 does not receive data from node 3 and node 3 does not receive data from node 1. Node 4 does not send any add; it only receives data from other nodes.

Data Link Area Structure

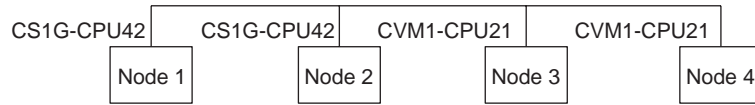

Data Link Areas

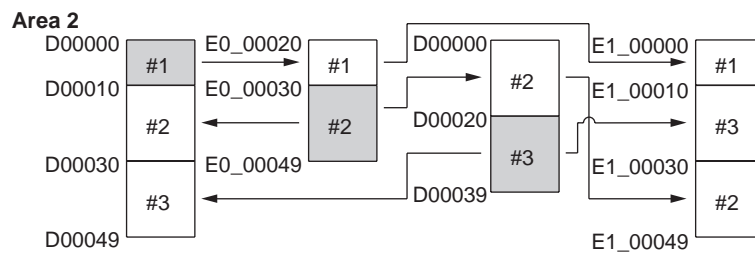
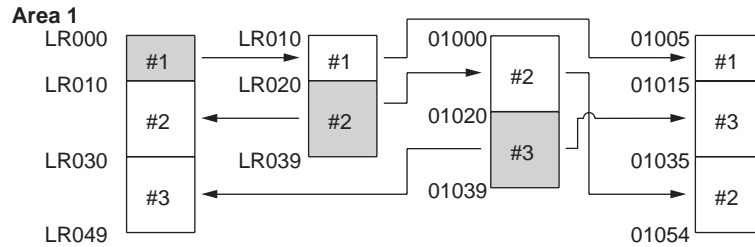

Only nodes in which a data link table has been created can participate in the data links.

In the data link table, the node sequence can be changed freely; however, the data link areas must be created consecutively.

Device Information Setting

Device Info set				DataLink table			
Node	Model name	Node	Model name	Node	Model name	Node	Model name
01	CS1G-42	17		33		49	
02	CS1G-42	18		34		50	
03	CVM1-CPU21	19		35		51	
04	CVM1-CPU21	20		36		52	
05		21		37		53	
06		22		38		54	

Data Link Tables

Node[01] PCTYPE[CS1G-42] Num of Nd [3] Status Word[-----]						
Node	<Area1>	Link Start Word	Link Wd	Num Wd	Source Wd	<Area2> Link Start Word
01	L00000	10	Send Area			D00000 10 Send Area
02	L00010	20	L00020			D00010 20 D00030
03	L00030	20	01020			D00030 20 D00020

Node[02] PCTYPE[CS1G-42] Num of Nd [2] Status Word[-----]						
Node	<Area1>	Link Start Word	Link Wd	Num Wd	Source Wd	<Area2> Link Start Word
01	L00010	10	L00000			D00020 10 D00000
02	L00020	20	Send Area			D00030 20 Send Area

Node[03] PCTYPE[CVM1-CPU21] Num of Nd [2] Status Word[-----]						
Node	<Area1>	Link Start Word	Link Wd	Num Wd	Source Wd	<Area2> Link Start Word
02	01000	20	L00020			D00000 20 D00030
03	01020	20	Send Area			D00020 20 Send Area

Node[04] PCTYPE[CVM1-CPU21] Num of Nd [3] Status Word[-----]						
Node	<Area1>	Link Start Word	Link Wd	Num Wd	Source Wd	<Area2> Link Start Word
01	01005	10	L00000			E1_00000 10 D00000
03	01015	20	01020			E1_00010 20 D00020
02	01035	20	L00020			E1_00030 20 D00030

SAMPLE3.CLK: Creating Data Link Groups within a Network

Data links consisting of multiple groups within a single network can be created by setting data link tables. Send and receive areas are created for only the nodes in each group, as shown below.

Data Link Area Structure

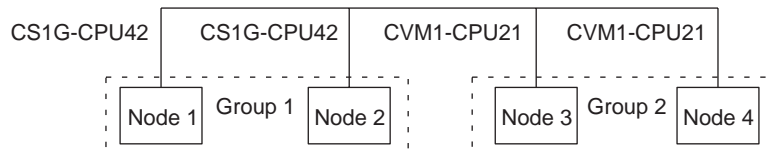

Data Link Areas

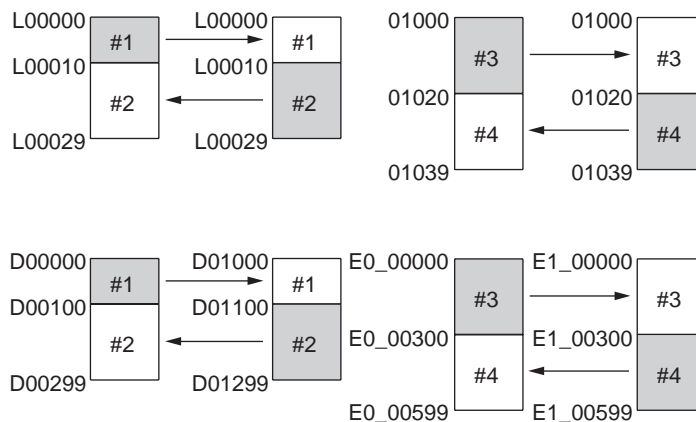

Device Information Setting

Device Info set				DataLink table			
Node	Model name	Node	Model name	Node	Model name	Node	Model name
01	CS1G-42	17		33		49	
02	CS1G-42	18		34		50	
03	CVM1-CPU21	19		35		51	
04	CVM1-CPU21	20		36		52	
05		21		37		53	
06		22		38		54	

Data Link Tables

Node[01] Pctype[CS1G-42] Num of Nd [2]				Edit Status Word[-----]				DataLink table
Node	<Area1> Link Start Word	Link Wd	Num Wd Source Wd	<Area2> Link Start Word	Link Wd	Num Wd Source Wd		
01	L00000	10	Send Area	D00000	100	Send Area		
02	L00010	20	L00010	D00100	200	D01100		

Node[02] Pctype[CS1G-42] Num of Nd [2]				Edit Status Word[-----]				DataLink table
Node	<Area1> Link Start Word	Link Wd	Num Wd Source Wd	<Area2> Link Start Word	Link Wd	Num Wd Source Wd		
01	L00000	10	L00000	D01000	100	D00000		
02	L00010	20	Send Area	D01100	200	Send Area		

Node[03] Pctype[CVM1-CPU21] Num of Nd [2]				Edit Status Word[-----]				DataLink table
Node	<Area1> Link Start Word	Link Wd	Num Wd Source Wd	<Area2> Link Start Word	Link Wd	Num Wd Source Wd		
03	01000	20	Send Area	E0_00000	300	Send Area		
04	01020	20	01020	E0_00300	300	E1_00300		

Node[04] Pctype[CVM1-CPU21] Num of Nd [2]				Edit Status Word[-----]				DataLink table
Node	<Area1> Link Start Word	Link Wd	Num Wd Source Wd	<Area2> Link Start Word	Link Wd	Num Wd Source Wd		
03	01000	20	01000	E1_00000	300	E0_00000		
04	01020	20	Send Area	E1_00300	300	Send Area		

SAMPLE4.CLK: Receiving Only Part of Send Data and Offsets

Only Area 2 is used in this example.

Note A Controller Link Support Board is used in this example. The Support Board does not have memory areas. The area settings are ignored and byte addresses are used. Refer to the *Controller Link Support Boards Operation Manual (W307)* for details on using a Controller Link Support Board.

Data Link Area Structure

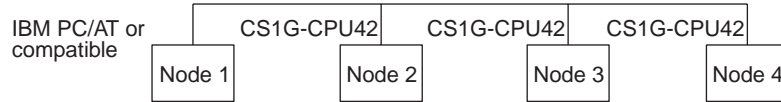

Data Link Areas

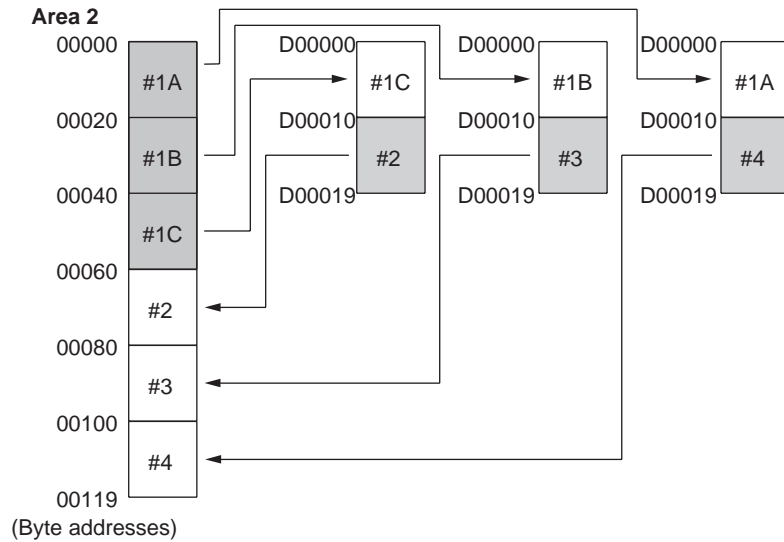

Device Information Setting

Device Info set DataLink table							
Node	Model name	Node	Model name	Node	Model name	Node	Model name
01	CLK Board	17		33		49	
02	CS1G-42	18		34		50	
03	CS1G-42	19		35		51	
04	CS1G-42	20		36		52	
05		21		37		53	
06		22		38		54	

Data Link Tables

Node[01] PCTYPE[CLK Board] Num of Nd [4] Edit DataLink table						
Status Word[-----]						
Node	<Area1>	Link Start Word[00000]	<Area2>	Link Start Word[D00000]		
	Link Wd	Num Wd	Source Wd	Link Wd	Num Wd	Source Wd
01	00000	0	Send Area	D00000	30	Send Area
02	00000	0	00000	D00030	10	D00010
03	00000	0	00000	D00040	10	D00010
04	00000	0	00000	D00050	10	D00010

Node[02] PCTYPE[CS1G-42] Num of Nd [2] Edit DataLink table								
Status Word[-----]								
Node	<Area1>	Link Start Word[00000]	<Area2>	Link Start Word[D00000]				
	Link Wd	Num Wd	Source Wd	Offset	Link Wd	Num Wd	Source Wd	Offset
01	00000	0	00000	0	D00000	10	D00020	20
02	00000	0	Send Area	---	D00010	10	Send Area	---

Node[03] PCTYPE[CS1G-42] Num of Nd [2] Edit DataLink table								
Status Word[-----]								
Node	<Area1>	Link Start Word[00000]	<Area2>	Link Start Word[D00000]				
	Link Wd	Num Wd	Source Wd	Offset	Link Wd	Num Wd	Source Wd	Offset
01	00000	0	00000	0	D00000	10	D00010	10
03	00000	0	Send Area	---	D00010	10	Send Area	---

Node[04] PCTYPE[CS1G-42] Num of Nd [2] Edit DataLink table								
Status Word[-----]								
Node	<Area1>	Link Start Word[00000]	<Area2>	Link Start Word[D00000]				
	Link Wd	Num Wd	Source Wd	Offset	Link Wd	Num Wd	Source Wd	Offset
01	00000	0	00000	0	D00000	10	D00000	10
04	00000	0	Send Area	---	D00010	10	Send Area	---

5-2-4 Automatic Setting: Select All

Data links can be automatically created by setting values in the DM parameter area of the PLC's CPU Unit of the startup node. The settings are made using a Programming Console or the CX-Programmer.

The startup node is the node from which the data links are activated. When automatically setting data links, data link operation is based on the values set in the startup node.

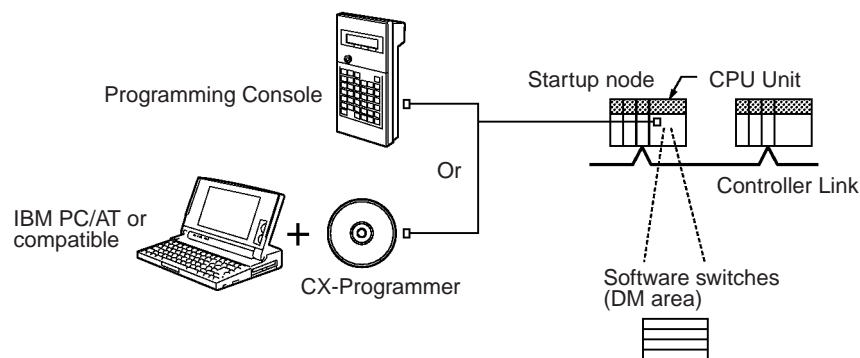

Note Data links can be started using one of the following (See p 127.)

- Using a software switch
- Using the Controller Link Support Software (Ver. 2.00 or higher) or the CX-Programmer's CX-Net utility
- Using FINS commands

CS-series Startup Node

Automatic setting for the CS Series can be performed using either equality layout (previous pattern), whereby each node is allocated the same link area size, or 1:N allocations, which allows an individually set exchange of data between the master node and slave nodes. There are 3 types of 1:N allocations, which use different allocation methods.

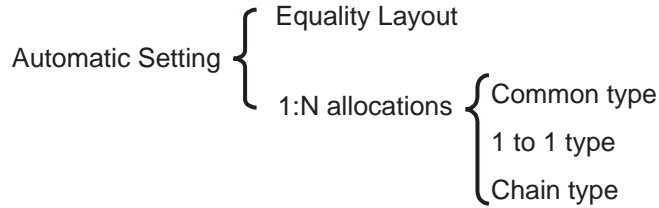

Automatic Setting, Equality Layout

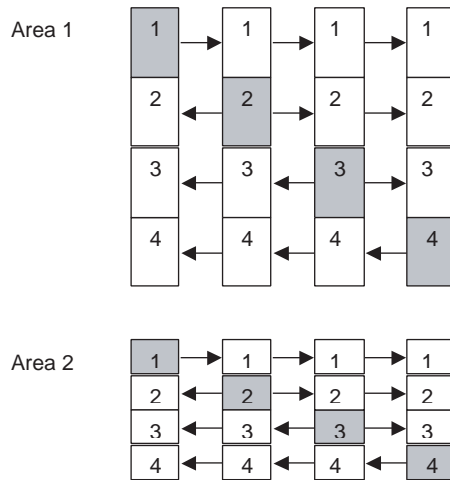

Features of Equality Layout

- The send areas for each node are of the same size.
- Area 1 can be set in bit-access areas and Area 2 can be set in the DM Area.
- Data link area allocation is performed in ascending order of node address.
- Each node can be specified to either participate or not participate in the data links.
- The data link areas are the same for all nodes participating in the data links.

Automatic Setting, 1:N Allocations

This method is used to simplify the setting of 1:N allocation data links between master and slave nodes.

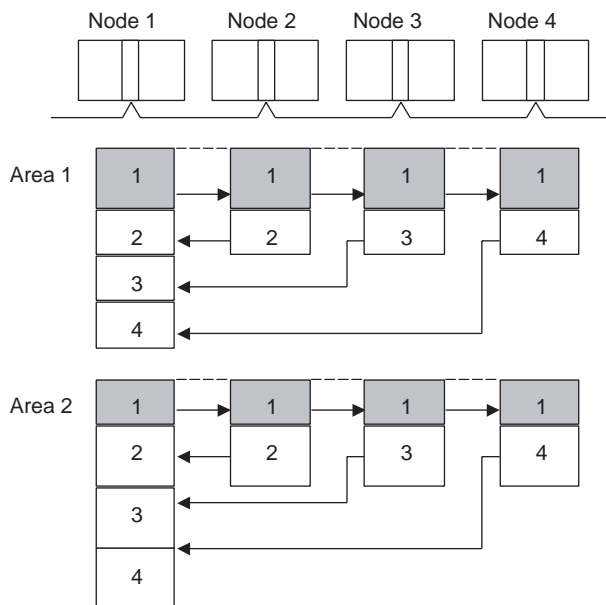

- There are three types of 1:N allocations.
- Programming Devices (including the Programming Console) are used to set the automatic data link mode in the DM parameters area of the CPU Unit used as the startup node.
- Node 1 is the master node.
- Area 1 can be set in the bit-access areas and Area 2 can be set in the DM Area.
- The send area sizes of the master and slave nodes are the same for each area.
- Send nodes are in the same ascending order as node numbers.
- Each node can be specified to either participate or not participate in the data links.
- The data link areas (data link start words) are common to all nodes participating in the data links.

Note 1. Automatic data link creation with 1:N allocations can only be used with the following Controller Link Units and Support Boards:

Type	Model
Optical Ring Systems	CS1W-CLK13 and CS1W-CLK12-V1 (for CS Series) (See note a.)
	CS1W-CLK53 and CS1W-CLK52-V1 (for CS Series) (See note a.)
	3G8F7-CLK13 and 3G8F7-CLK12-EV1 (for PCI bus)
	3G8F7-CLK53 and 3G8F7-CLK52-EV1 (for PCI bus)

Note (a) For Pre-Ver. 1.2 CS1W-CLK12-V1 or CS1W-CLK52-V1 Controller Link Units, use those from lot number 0306□□_□□□□ or later (manufactured after May 2003). Earlier models (from lot number 0305□□_□□□□ or earlier) do not support automatic data link creation with 1:N allocations.

Lot number notation: The first two digits refer to the year (last two digits of years from 2000 onwards), and the following two digits indicate the month (01 to 12, for January to December, respectively). (The last 7 digits are not relevant.)

2. Controller Link Units and Support Boards other than those listed above cannot participate in 1:N allocation data links. They can, however, join the network if the parameter for specifying data link participation status in the DM parameters area is set so that they do not participate in the data links.
3. For automatic data link creation with 1:N allocations, use the CX-Net in CX Programmer version 3.2 or later.

Set the following DM parameter area settings in the PLC that is the startup node.

N: DM 30000 + 100 Controller Link Unit number

	15	14	13	12	11	10	9	8	7	6	5	4	3	2	1	0
Word N	-	-	0	0	0	0	-	-	-	0			0	0	0	-

0: Always specify 0.
 -: Other settings

Data link mode
 000: Manual setting
 001: Automatic setting (equality layout)
 101: Automatic setting (1:N allocations)

Automatic Setting, Equality Layout

	15	14	13	12	11	10	9	8	7	6	5	4	3	2	1	0
N+1	Area 1 data link start word (BCD) *1															
N+2	Area 1 type															00
N+3	Number of send words per node of Area 1 (BCD)															
N+4	Rightmost 4 digits of data link start word of Area 2 (DM area) (BCD)															
N+5	Area 2 type															Leftmost digit of data link start word of Area 2 (BCD)
N+6	Number of send words per node of Area 2 (BCD)															
N+7	First data link status word (BCD)															

	15	14	13	12	11	10	9	8	7	6	5	4	3	2	1	0
N+8	16	15	14	13	12	11	10	9	8	7	6	5	4	3	2	1
N+9	32	31	30	29	28	27	26	25	24	23	22	21	20	19	18	17
N+10	48	47	46	45	44	43	42	41	40	39	38	37	36	35	34	33
N+11	-	-	62	61	60	59	58	57	56	55	54	53	52	51	50	49

← Nodes to participate in the data links (*2)
 The numbers indicate node numbers.
 The value assigned indicates whether the node is to participate in the data links.
 Participate: 1
 Not participate: 0

-: Not used.

*1: BCD: Set the value as binary-coded decimal.

*2: With Optical Bus (CLK11) Optical Link Units, N+10 and N+11 (node addresses 33 to 62) cannot be used.

Settings

Item	Setting range
Data link mode	Specify automatic (01).
Area 1 data link start word	Set the word address in BCD. CIO Area: CIO 000 to CIO 6143 LR Area: LR 00 to 199 (*) *: When a word between LR 000 and LR 199 is specified, the data link area will be allocated between CIO 1000 and CIO 1199.

Item	Setting range
Area 1 type	Set the area for Area 1 in BCD. CIO Area: 80 Hex LR Area: 86 Hex Area 1 not used: 00 Hex
Number of send words per node of Area 1	Set the number of words in BCD between 0 and 1,000. The total number of send words for Area 1 and Area 2 must not exceed 1,000. When Area 1 is not used, set to 0.
Area 2 data link start word	Set the word address in BCD. DM Area: DM 0000 to DM 32767 EM Area: Banks 00 to 12, EM 0000 to EM 32767
Area 2 type	Set the area type for Area 2 in BCD. DM Area: 82 Hex EM Area: Banks 00 to 07: 90 to 97 Hex Banks 08 to 12: A8 to AC Hex Area 2 not used: 00 Hex
Number of send words per node of Area 2	Set the number of words in BCD between 0 and 1,000. The total number of send words of Area 1 and Area 2 must not exceed 1,000. When Area 2 is not used, set to 0.
First data link status word	Set in BCD the first word used for storing data link status. An area of 16 words is used for storing status. 0 (*), CIO 000 to CIO 6128 Status is stored in an the CIO Area only. *: When 0 is set, the status is saved in CIO 1500 + unit number x 25 (+ 7 to + 22).
Nodes to participate in the data links	Set to ON (1) the bits corresponding to the nodes participating in the data links. The data link will not start unless the startup node itself is set as a participating node. The data link will not start if the node is set to a parameter exceeding the "maximum node address" of the network parameter.

Note (a) The total number of words in data link send and receive areas must not exceed 20,000 per node when using Controller Link Units with unit Ver. 1.2 or later, or 12,000 words per node if using pre-Ver. 1.2 Controller Link Units.

(b) The following values must be satisfied for each node for the data link Area 1 and Area 2 so that the final word in the data link does not go beyond the last word in the PLC memory area.

$$\begin{aligned}
 &(\text{Data link start word} - 1) + \text{Total number of send/receive} \\
 &\text{words in area} \leq \begin{array}{l} 6143 \text{ (CIO Area)} \\ 199 \text{ (LR Area)} \\ 32767 \text{ (DM Area, EM Area)} \end{array}
 \end{aligned}$$

(c) When using Area 1 only, set the data link start word, type, and the number of send words of Area 2 to 0.

(d) When using Area 2 only, set the data link start word, type, and the number of send words of Area 1 to 0.

(e) The startup node must be set as a participating node of the data links. If not, the data links will not start.

1:N Allocations, Common Type

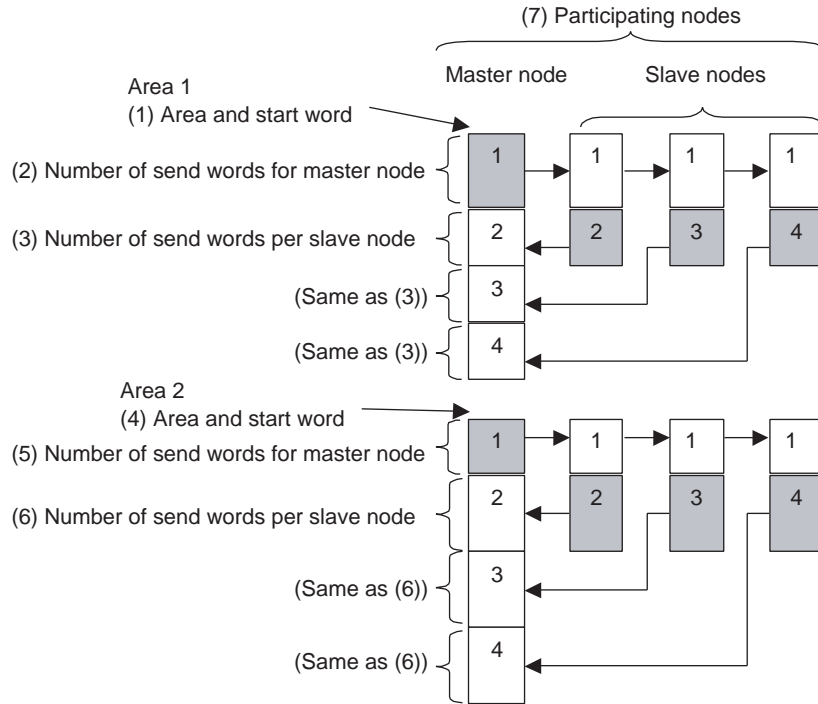

Features of Common Type 1:N Allocation

- Data communications are 1:1 between the master node and each of the slave nodes.
- All slave nodes receive the data sent by the master node.
- The master node receives all data sent by the slaves. Therefore, the reception size for the master node is the node send data size multiplied by the number of slave nodes.
- Slaves do not exchange data with other slaves.
- Area 1 is set in the bit-access areas and Area 2 is set in the DM Area.
- Data link areas are allocated in ascending order of node addresses.
- Each node can be specified to either participate or not participate in the data links.

Address N: $D30000 + (100 \times \text{Controller Link Unit number})$

	15	14	13	12	11	10	9	8	7	6	5	4	3	2	1	0
Word N	-	-	0	0	-	0	0	0	-	1	0	1	0	0	0	-

When bits 6, 5 and 4 are set to 1, 0, and 1 respectively, automatic setting with 1:N allocations is specified.

	15				8				7				0				
N+12	1:N allocation type (Set value 0001 = Common type)															-	
N+13	Start word for Area 1 (bit-access area, BCD)															(1)	
N+14	Area 1 type				00												
N+15	Area 1 number of send words for master node (BCD)															(2)	
N+16	Area 1 number of send words per slave node (BCD)															(3)	
N+17	Rightmost 4 digits of start word for Area 2 (DM Area) (BCD)															(4)	
N+18	Area 2 type				Leftmost digit of start word for Area 2 (BCD)												
N+19	Area 2 number of send words for master node (BCD)															(5)	
N+20	Area 2 number of send words per slave node (BCD)															(6)	
N+21	First word to store data link status (bit-access area, BCD)															-	
N+22	16	15	14	13	12	11	10	9	8	7	6	5	4	3	2	1	(7)
N+23	32	31	30	29	28	27	26	25	24	23	22	21	20	19	18	17	
N+24	48	47	46	45	44	43	42	41	40	39	38	37	36	35	34	33	
N+25	-	-	62	61	60	59	58	57	56	55	54	53	52	51	50	49	

Words N+22 through N+25 register nodes that will participate in the data links. The numbers shown in the table are the node addresses. The bit status for each node address indicates whether the node is to participate in the data links.

- 1 (ON):Participate
- 0 (OFF):Not participate

Note When using automatic data link creation with 1:N allocations, set DM parameters area words N+2 to N+11 (which were previously used for automatic setting with equality layout) to 0.

Setting Range for Automatic Setting, 1:N Allocations, Common Type

Item	Setting range
Data link mode	Specify automatic data link creation with 1:N allocations.
1:N allocation type	Specify <i>Common type</i> .
Start word for Area 1	Set the word address in BCD. CIO Area: 0000 to 6143 LR Area: LR 000 to LR 199 (CIO 1000 to CIO 1199) (*) DM Area: DM 00000 to DM 32767 EM Area: Banks 0 to 12: EM 00000 to EM 32767 *: When a word between LR 000 and LR 199 is specified, the data link area will be allocated between words CIO 1000 and CIO 1199 in the CIO Area.
Area for Area 1	Set the area for data link Area 1 as a hexadecimal number. CIO Area: 80 hex LR Area: 86 hex DM Area: 82 hex EM Area Banks 0 to 7: 90 to 97 hex Banks 8 to 12: A8 to AC hex When Area 1 is not used: 00 hex
Area 1 number of send words for master node	Set the number of words in BCD between 0 and 1,000. The total number of send words for master node of Area 1 and Area 2 must not exceed 1,000. Set to 0 when Area 1 is not to be used or when the master node will transmit no data.

Item	Setting range
Area 1 number of send words per slave node	Set the number of words in BCD between 0 and 1,000. The total number of send words per slave node of Area 1 and Area 2 must not exceed 1,000. Set to 0 when Area 1 is not to be used or when the slave node will transmit no data.
Start word for Area 2 (DM Area)	Set the word address in BCD. CIO Area: 0000 to 6143 LR Area: LR 000 to LR 199 (CIO 1000 to CIO 1199) (*) DM Area: DM 00000 to DM 32767 EM Area: Banks 0 to 12: EM 00000 to EM 32767 *: When a word between LR 000 and LR 199 is specified, the data link area will be allocated between words CIO 1000 and CIO 1199 in the CIO Area.
Area for Area 2	Set the area type of Area 2 as a hexadecimal number. CIO Area: 80 hex LR Area: 86 hex DM Area: 82 hex EM Area Banks 0 to 7: 90 to 97 hex Banks 8 to 12: A8 to AC hex When Area 2 is not used: 00 hex
Area 2 number of send words for master node	Set the number of words in BCD between 0 and 1,000. The total number of send words per master node of Area 1 and Area 2 must not exceed 1,000. Set to 0 when Area 2 is not to be used, or when the master node will transmit no data.
Area 2 number of send words per slave node	Set the number of words in BCD between 0 and 1,000. The total number of send words per slave node of Area 1 and Area 2 must not exceed 1,000. Set to 0 when Area 2 is not to be used, or when the slave node will transmit no data.
First word to store data link status	Set in BCD the first word used for storing data link status. When automatic setup is used, status can be stored in the CIO Area only. The number of words used to store status depends on the data link status storage format specification as below. 0 (*) 1 to 6128 (32 nodes max., 8-bit format: 16 words used) *: When 0 is set, the status is saved in CIO 1500 + unit number x 25 (+ 7 to + 22).
Nodes to participate in the data links	Turn ON the bits corresponding to the nodes participating in the data links. The data links will not start unless the startup node itself is set as a participating node.

- Note**
1. Node 1 is the master node. Node 1 must be registered as a participating node.
 2. The startup node (the node that sets the above DM Area parameters and starts the data links) must be registered as a node participating in the data links. If it is not registered, the data links will not start.
 3. When using Area 2 only, set the area for Area 1 and the number of send words for Area 1 to 0.
 4. When using Area 1 only, set the area for Area 2 and the number of send words for Area 2 to 0.

5. The total number of words in data link send and receive areas must not exceed 20,000 per node when using Controller Link Units with unit Ver. 1.2 or later, or 12,000 words per node if using pre-Ver. 1.2 Controller Link Units. The total number of words in data link send and receive areas of a master node must satisfy the following values.

Total number of words in the data link send and receive areas of master node = Area 1 number of send words for master node

+ Area 1 number of send words per slave node

× Number of slave nodes participating in data links

+ Area 2 number of send words for master node

+ Area 2 number of send words per slave node

× Number of slave nodes participating in data links

6. The following values must be satisfied to ensure that data link areas 1 and 2 are fully contained within the specified area.

(Start word – 1) + (Total of send and receive words for master node*)

≤ 6143 (when using the CIO or AR Area)

199 (when using the LR Area)

32,767 (DM Area or EM Area)

*: Total of send and receive words for master node =

Number of send words for master node

+ Number of send words per slave node

× Number of slave nodes participating in data links

7. If a node that does not actually exist (e.g., a node that is scheduled to be added in the future) is registered as a node that will participate in the data links, a data link area for that node will be allocated in the master node, and the send and receive areas for it will be refreshed with 0 data.
8. Automatic data link creation with 1:N allocations can be performed only with CS1W-CLK12-V1 and CS1W-CLK52-V1 Controller Link Units from lot number 0306□□_□□□□, or CS1W-CLK13 and CS1W-CLK53 Controller Link Units. If any other model is used, the LNK indicator will flash and it will not be possible for the Unit/Board to participate in automatic setting of 1:N allocations. (The first four digits of the lot number indicate the year and month of manufacture from 2000 onwards.)
9. If automatic data link creation with 1:N allocations is to be set up using CX-Net operations in the CX-Programmer, use CX-Programmer version 3.2 or later. Setup cannot be performed using CX-Programmer version 3.1 or earlier.
10. The startup node (the node that sets the above DM Area parameters and starts the data links) can be set as either a master node or a slave node.

1:N Allocations, 1 to 1 Type

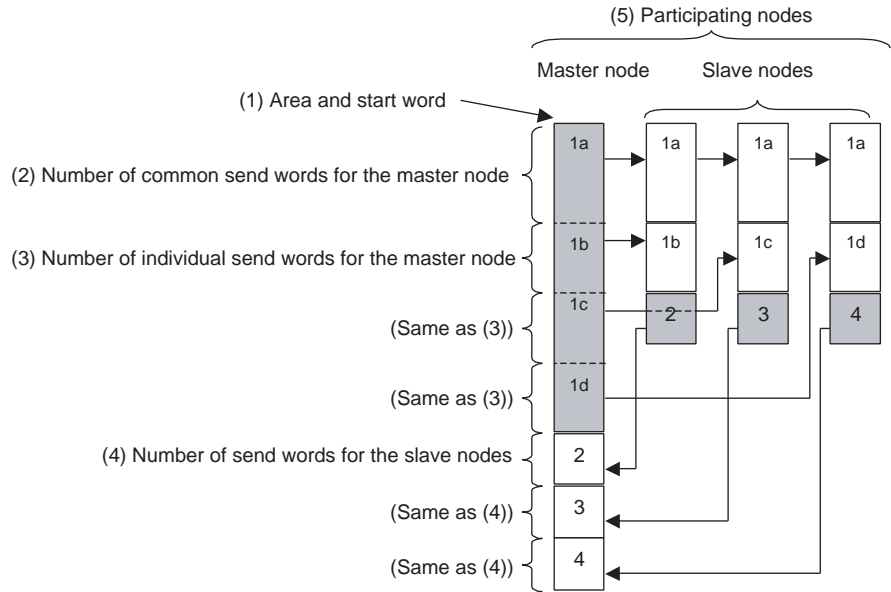

Features of 1 to 1 Type 1:N Allocation

- Data communications are 1:1 between the master node and each of the slave nodes.
- All slave nodes receive part of the data sent by the master node. Each slave node also receives unique data from the master node (see a to d in figure). The data sizes are fixed for all nodes.
- The master node receives all data sent by the slaves. The data sizes are fixed for all nodes.
- Slaves do not exchange data with other slaves.
- One area is set in the bit-access areas (e.g., CIO Area) or DM Area.
- Data link areas are allocated in ascending order of node addresses.
- Each node can be specified to either participate or not participate in the data links.

Address N: $D30000 + (100 \times \text{Controller Link Unit number})$

	15	14	13	12	11	10	9	8	7	6	5	4	3	2	1	0
Word N	-	-	0	0	-	0	0	0	-	1	0	1	0	0	0	-

When bits 6, 5 and 4 are set to 1, 0 and 1 respectively, automatic setting with 1:N allocations is specified.

	15				8				7				0				
N+12	1:N allocation type setting (Set value 0002 = 1 to 1 type)															-	
N+13	Rightmost 4 digits of start word (BCD)															(1)	
N+14	Area 1 type							Leftmost digit of area start word (BCD)									
N+15	Number of common send words for master node (BCD)															(2)	
N+16	Number of individual send words for master node (BCD)															(3)	
N+17	Number of send words per slave node (BCD)															(4)	
N+18	0000 (Reserved area)															-	
N+19	0000 (Reserved area)															-	
N+20	0000 (Reserved area)															-	
N+21	First word to store data link status (bit-access area) (BCD)															-	
N+22	16	15	14	13	12	11	10	9	8	7	6	5	4	3	2	1	(5)
N+23	32	31	30	29	28	27	26	25	24	23	22	21	20	19	18	17	
N+24	48	47	46	45	44	43	42	41	40	39	38	37	36	35	34	33	
N+25	-	-	62	61	60	59	58	57	56	55	54	53	52	51	50	49	

Words N+22 through N+25 register nodes that will participate in the data links. The numbers shown in the table are the node addresses. The bit status for each node address indicates whether the node is to participate in the data links.

- 1 (ON): Participate
- 0 (OFF): Not participate

- Note**
1. Leave the reserved words set to 0 (N+18 to N+20).
 2. When using automatic data link creation with 1:N allocations, set DM parameters area words N+2 to N+11 (which were previously used for automatic setting with equality layout) to 0.

Setting Ranges for Automatic Creation with 1:N allocations, 1 to 1 Type

Item	Setting range
Data link mode	Specify automatic data link creation with 1:N allocations.
1:N allocation type	Specify <i>1 to 1 type</i> .
Area start word	Set the word address in BCD. CIO Area: 0 to 6143 LR Area: LR 000 to LR 199 (CIO 1000 to CIO 1199) (*) DM Area: D00000 to D32767 EM Area: Banks 0 to 12 E00000 to E32767 *: When a word between LR 000 and LR 199 is specified, the data link area will be allocated between words word 1000 and word 1199 in the CIO Area.
Area type	Set the area type of Area 1 as a hexadecimal number. CIO Area: 80 hex LR Area: 86 hex DM Area: 82 hex EM Area Banks 0 to 7: 90 to 97 hex Banks 8 to 12: A8 to AC hex

Item	Setting range
Number of common send words for the master node	Set the number of words in BCD between 0 and 1,000. The number of common send words per master node added to the number of individual send words per master node multiplied by the number of slave nodes participating in the data links must not exceed 1,000. Set to 0 if common data is not to be sent from a master node to a slave node.
Number of individual send words for the master node	Set the number of words in BCD between 0 and 1,000. The number of common send words per master node added to the number of individual send words per master node multiplied by the number of slave nodes participating in the data links must not exceed 1,000. Set to 0 if individual data is not to be sent from a master node to a slave node.
Number of send words per slave node	Set the number of words in BCD between 0 and 1,000. Set to 0 if the slave node will transmit no data.
First data link status word	Set in BCD the first word used for storing data link status. When automatic setup is used, status can be stored in the CIO Area only. The number of words used to store status depends on the data link status storage format specification as below. 0 (*) 1 to 6128 (32 nodes max., 8-bit format: 16 words used) *: When 0 is set, the status is saved in CIO 1500 + unit number x 25 (+ 7 to + 22).
Nodes to participate in the data links	Set to ON (1) the bits corresponding to the nodes participating in the data links. Data links will not start unless the startup node itself is set as a participating node.

Note

1. Node 1 becomes the master node. Node 1 must be registered as a participating node.
2. Only one area can be specified when using the 1 to 1 type of 1:N allocation.
3. The startup node (the node that sets the above DM parameters and starts the data link) must be registered as a node participating in the data link. If it is not registered, the data links will not start.
4. The total number of words in data link send and receive areas must not exceed 20,000 per node when using Controller Link Units with unit Ver. 1.2 or later, or 12,000 words per node if using pre-Ver. 1.2 Controller Link Units. The total number of words in data link send and receive areas of a master node must satisfy the following values. Because the number of master node words is greatest when 1:N allocation is used, the value can be estimated from the number of master node words.
Total number of words in the data link send and receive areas of master node =
Number of common send words in master node
+ Number of individual send words in master node
× Number of slave nodes participating in data links
+ Number of send words in slave node
× Number of slave nodes participating in data links
5. The following values must be satisfied to ensure that the data link area is fully contained within the specified area.

(Area start word - 1) + (Total number of send and receive words of master node.*)
 ≤ 6143 (when using the CIO or AR Area)
 199 (when using LR Area)
 32767 (when using DM or EM Area)

*:Total number of send and receive words in master node =
 Number of common send words in master node
 + Number of individual send words in master node × Number of slave nodes participating in data links
 + Number of send words in slave node × Number of slave nodes participating in data links

6. If a node that does not actually exist (e.g., a node that is scheduled to be added in the future) is registered as a node that will participate in the data links, a data link area for that node will be allocated in the master node, and the send and receive words will be refreshed with "0" data.
7. Automatic data link creation with 1:N allocations can be performed only with CS1W-CLK12-V1 and CS1W-CLK52-V1 Controller Link Units from lot number 0306□□_□□□□, or CS1W-CLK13 and CS1W-CLK53 Controller Link Units. If any other model is used, the LNK indicator will flash and it will not be possible for the Unit/Board to participate in automatic setting of 1:N allocations. (The first four digits of the lot number indicate the year and month of manufacture from 2000 onwards.)
8. If automatic data link creation with 1:N allocations is to be set up using CX-Net operations in the CX-Programmer, use CX-Programmer version 3.2 or later. Setup cannot be performed using CX-Programmer version 3.1 or earlier.
9. The startup node (the node that sets the above DM Area parameters and starts the data links) can be set as either a master node or a slave node.

1:N Allocation, Chain Type

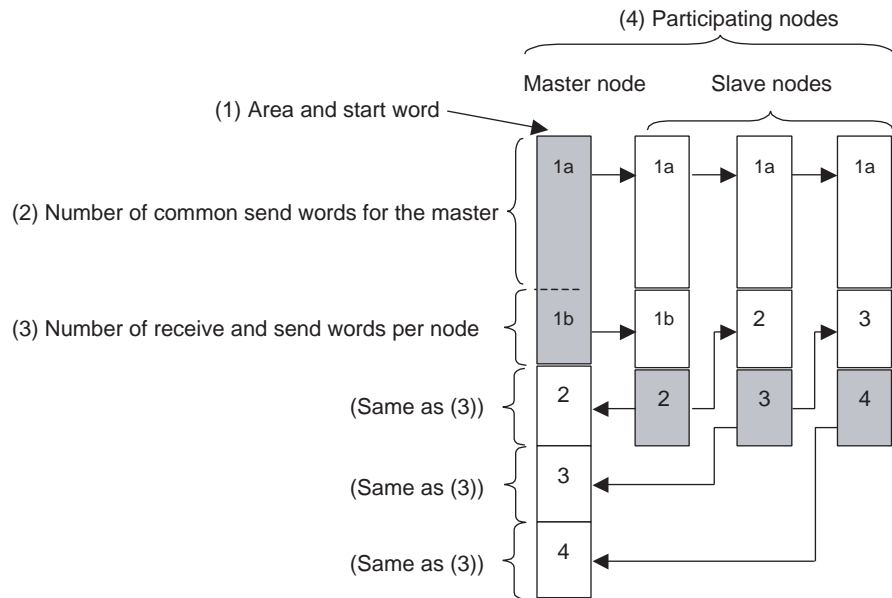

Features of Chain Type 1:N Allocation

- Data communications are 1:1 between the master node and each of the slave nodes.
- All slave nodes receive part of the data sent by the master node. (1a in figure).

- The master node receives all data sent by the slaves. The data sizes are fixed for all nodes.
- Each slave nodes receives data from the previous node and then sends data to the next node. Data is thus passed in ascending order of the nodes that are participating in the data link.
- One area is set in the bit-access areas (e.g., CIO Area) or DM Area.
- Data link areas are allocated in ascending order of node addresses.
- Each node can be specified to either participate or not participate in the data links.

Address N: D30000 + (100 × Controller Link Unit number)

	15	14	13	12	11	10	9	8	7	6	5	4	3	2	1	0
Word N	-	-	0	0	-	0	0	0	-	1	0	1	0	0	0	-

When bits 6, 5 and 4 are set to 1, 0 and 1 respectively, automatic setting with 1:N allocation is specified.

	15							8	7							0	
N+12	1:N allocation type setting (Set value 0003=Chain type)															-	
N+13	Rightmost 4 digits of area start word (BCD)															(1)	
N+14	Area 1 type							Leftmost digit of area start word (BCD)									
N+15	Number of common send words for master (BCD)															(2)	
N+16	Number of receive and send words per node (BCD)															(3)	
N+17	0000 (Reserved area)															-	
N+18	0000 (Reserved area)															-	
N+19	0000 (Reserved area)															-	
N+20	0000 (Reserved area)															-	
N+21	First word to store data link status (bit-access area) (BCD)															-	
N+22	16	15	14	13	12	11	10	9	8	7	6	5	4	3	2	1	(4)
N+23	32	31	30	29	28	27	26	25	24	23	22	21	20	19	18	17	
N+24	48	47	46	45	44	43	42	41	40	39	38	37	36	35	34	33	
N+25	-	-	62	61	60	59	58	57	56	55	54	53	52	51	50	49	

Words N+22 through N+25 register nodes that will participate in the data links. The numbers shown in the table are the node addresses. The bit status for each node address indicates whether the node is to participate in the data links.

- 1 (ON):Participate
- 0 (OFF):Not participate

- Note**
1. Set 0 as the values of the reserved areas (N+17 to N+20).
 2. When using automatic data link creation with 1:N allocation, set DM parameters area words N+2 to N+11 (which were previously used for automatic setting with equality layout) to 0.

Setting Range for Automatic Creation with 1:N Allocation, Chain Type

Item	Setting range
Data link mode	Specify automatic data link creation with 1:N allocations.
1:N allocation type	Specify <i>Chain Type</i> .

Item	Setting range
Area start word	Set the word address in BCD. CIO Area: 0 to 6143 LR Area: LR 000 to LR 199 (1000 to 1199) (*) DM Area: DM 0 to 32767 EM Area: Banks 0 to 12 EM 0 to 32767 *: When a word between LR 000 and LR 199 is specified, the data link area will be allocated between words 1000 and 1199 in the CIO Area.
Area	Set the area type of Area 1 as a hexadecimal number. CIO Area: 80 hex LR Area: 86 hex DM Area: 82 hex EM Area Banks 0 to 7: 90 to 97 hex Banks 8 to 12: A8 to AC hex
Number of common send words for the master node	Set the number of words in BCD between 0 and 1,000. The number of common send words for the master node added to the number of send and receive words per node must not exceed 1,000. Set to 0 if send and receive data is not to be sent from a master node to a slave node.
Number of receive and send words per node	Set the number of words in BCD between 0 and 1,000. The number of common send words in master node added to the number of send and receive words per node must not exceed 1,000. Set to 0 if send and receive data is not to be sent.
First word to store data link status	Set in BCD the first word used for storing data link status. When automatic setting is used, status can be stored in the CIO Area only. The number of words used to store status depends on the data link status storage format specification as below. 0 (*) 1 to 6128 (32 nodes max., 8-bit format: 16 words used) *: When 0 is set, the status is saved in CIO 1500 + unit number x 25 (+ 7 to + 22).
Nodes to participate in the data links	Set to ON (1) the bits corresponding to the nodes participating in the data links. The data link will not start unless the startup node itself is set as a participating node.

- Note**
1. Node 1 becomes the master node. Node 1 must be registered as a participating node.
 2. Only one area can be specified when using the chain type of 1:N allocation.
 3. The startup node (the node that sets the above DM parameters and starts the data link) must be registered as a node participating in the data link. If it is not registered, the data links will not start.
 4. The total number of words in data link send and receive areas must not exceed 20,000 per node when using Controller Link Units with unit Ver. 1.2 or later, or 12,000 words per node if using pre-Ver. 1.2 Controller Link Units. The total number of words in data link send and receive areas of a master node must satisfy the following values. Because the number of master node words is greatest when 1:N allocation is used, the value can be estimated from the number of master node words.

- Total number of words in the data link send and receive areas of master node = Number of common send words in master node
+ Number of individual send words in each node × Number of nodes participating in data links (including both master nodes and slave nodes)
5. The following values must be satisfied to ensure that the data link area is fully contained within the specified area.
(Area start word -1) + (Total number of send and receive words of master node (*))
≤ 6143 (when using the CIO or AR Area)
199 (when using LR Area)
32767 (when using DM or EM Area)
*: Total number of send and receive words in master node = Number of common send words in master node
+ Number of send and receive words in master node × Number of nodes participating in data links (including both master nodes and slave nodes)
 6. If a node that does not actually exist (e.g., a node that is scheduled to be added in the future) is registered as a node that will participate in the data links, a data link area for that node will be allocated in the master node, and the send and receive areas for it will be refreshed with 0 data.
 7. Automatic data link creation with 1:N allocations can be performed only with CS1W-CLK12-V1 and CS1W-CLK52-V1 Controller Link Units from lot number 0306□□_□□□□, or CS1W-CLK13 and CS1W-CLK53 Controller Link Units. If any other model is used, the LNK indicator will flash and it will not be possible for the Unit/Board to participate in automatic setting of 1:N allocations. (The first four digits of the lot number indicate the year and month of manufacture from 2000 onwards.)
 8. If automatic data link creation with 1:N allocations is to be set up using CX-Net operations in the CX-Programmer, use CX-Programmer version 3.2 or later. Setup cannot be performed using CX-Programmer version 3.1 or earlier.
 9. The startup node (the node that sets the above DM Area parameters and starts the data links) can be set as either a master node or a slave node.

CVM1 or CV-series Startup Node

Set the following DM parameter area settings in the PLC that is the startup node.

N: DM 2000 + 100 Controller Link Unit number

	15	14	13	12	11	10	9	8	7	6	5	4	3	2	1	0
Word N	-	-	0	0	0	0	-	-	-	0			0	0	0	-

0: Always specify 0.
 -: Other settings

Data link mode
 Set to 01 for automatic setting.
 (00 is for manual setting. Other values are invalid.)

	15	8	7	0
N+1	Area 1 data link start word (BCD) *1			
N+2	Area 1 type	00		
N+3	Number of send words per node of Area 1 (BCD)			
N+4	Rightmost 4 digits of data link start word of Area 2 (DM area) (BCD)			
N+5	Area 2 type	Leftmost digit of data link start word of Area 2 (BCD)		
N+6	Number of send words per node of Area 2 (BCD)			
N+7	First data link status word (BCD)			

	15	14	13	12	11	10	9	8	7	6	5	4	3	2	1	0
N+8	16	15	14	13	12	11	10	9	8	7	6	5	4	3	2	1
N+9	32	31	30	29	28	27	26	25	24	23	22	21	20	19	18	17
N+10	48	47	46	45	44	43	42	41	40	39	38	37	36	35	34	33
N+11	-	-	62	61	60	59	58	57	56	55	54	53	52	51	50	49

← Nodes to participate in the data links (*2)
 The numbers indicate node numbers.
 The value assigned indicates whether the node is to participate in the data links.
 Participate: 1
 Not participate: 0

-: Not used.
 *1: BCD: Set the value as binary-coded decimal.
 *2: With Optical Bus (CLK11) Optical Link Units, N+10 and N+11 (node addresses 33 to 62) cannot be used.

Settings

Item	Setting range
Data link mode	Specify automatic (01).
Area 1 data link start word	Set the word address in BCD. CIO Area: CIO 0000 to CIO 2555 LR Area: LR 000 to LR 199 (*) *: When a word between LR 000 and LR 199 is specified, the data link area will be allocated between CIO 1000 and CIO 1199.
Area 1 type	Set the area for Area 1 in BCD. CIO Area: 80 Hex LR Area: 86 Hex Area 1 not used: 00 Hex
Number of send words per node of Area 1	Set the number of words in BCD between 0 and 1,000. The total number of send words of Area 1 and Area 2 must not exceed 1,000. When Area 1 is not used, set to 0.
Area 2 data link start word	Set the word address in BCD. DM Area: DM 0000 to DM 8191 (CV500/CVM1-CPU01) DM 0000 to DM 24575 (Other CPU Units) EM Area: Banks 00 to 07, EM 0000 to EM 32765 (EM must be installed)

Item	Setting range
Area 2 type	Set the area for Area 2 in BCD. DM Area: 82 Hex EM Area: Banks 00 to 07: 90 to 97 Hex Area 2 not used: 00 Hex
Number of send words per node of Area 2	Set the number of words in BCD between 0 and 1,000. The total number of send words of Area 1 and Area 2 must not exceed 1,000. When Area 2 is not used, set to 0.
First data link status word	Set in BCD the first word used for storing data link status. An area of 16 words is used for storing status. 0 (*) or CIO 0001 to CIO 2540 Status is stored in the CIO area only. *: When 0 is set, the status is saved in CIO 1500 + unit number x 25 (+ 7 to + 22).
Nodes participating in the data links	Set to ON (1) the bits corresponding to the nodes participating in the data links. The data link will not start unless the startup node itself is set as participating node. The data link will not start if the node is set to a parameter exceeding the "maximum node address" of the network parameter.

Note (a) The total number of words in data link send and receive areas must not exceed 8,000 per node.

(b) The following values must be satisfied for each node for the data link Area 1 and Area 2 so that the final word in the data link does not go beyond the last word in the PLC memory area.

$$\begin{aligned}
 &(\text{Data link start word} - 1) + \text{Total number of send/receive} \\
 &\text{words in area} \leq \begin{matrix} 2555 \text{ (CIO Area)} \\ 199 \text{ (LR Area)} \\ 8191 \text{ (DM Area for CV500/CVM1-CPU01)} \\ 24575 \text{ (DM Area for other CPU Units)} \\ 32765 \text{ (EM Area)} \end{matrix}
 \end{aligned}$$

(c) When using Area 1 only, set the data link start word, type, and the number of send words of Area 2 to 0.

(d) When using Area 2 only, set the data link start word, type, and the number of send words of Area 1 to 0.

(e) The startup node must be registered as a participating node of the data links. If not, the data links will not start.

Note 1. When data links are automatically created for networks containing CS-series, CVM1, and CV-series PLCs, the linkable area is restricted to the area of the CVM1-CV-series PLC because it is smaller than that of CS-series PLCs.

Example: DM Area

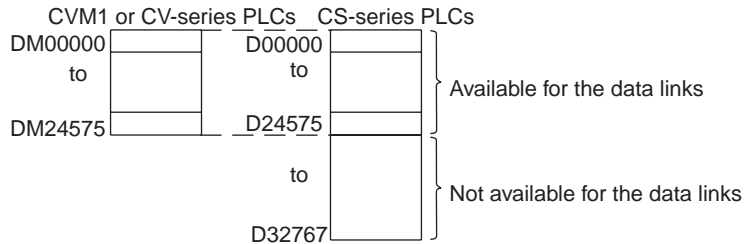

2. The following limitations apply when Optical Bus (CLK11) and Optical Ring (H-PCF cable) (CLK12, CLK12-V1, or CLK13) Controller Link Units are used in combination.
 - The data that can be received by the Optical Bus Controller Link Units is limited to node addresses 1 to 32, and the data link status that is reflected is also limited to these node addresses.
 - When data links are set automatically, and an Optical Ring Controller Link Unit is used as the startup node, register the participating nodes within the range of node addresses 1 to 32. If a node address of 33 or higher is included, a data link table setting error will be generated at the Optical Ring Controller Link Unit.
 - When setting data links manually, the receiving nodes that are set in the Optical Bus Controller Link Unit data link table must be within the range of node addresses 1 to 32. If a node address of 33 or higher is included, a data link table setting error will be generated at the Optical Bus Controller Link Unit.

5-2-5 Automatic Setting Example

This section shows an example of DM parameter area settings and the data link areas that are created as a result.

DM Parameter Area Settings (Equality Layout)

Set the parameters in the startup node as follows:

N	0	0	1	0	← Data link mode: Automatic
N+1	0	0	0	0	} ← Area 1 data link start word: LR 00
N+2	8	6	0	0	
N+3	0	0	1	0	← Number of words: 10
N+4	1	0	0	0	} ← Area 2 data link start word: DM 1000
N+5	8	2	0	0	
N+6	0	2	0	0	← Number of words: 200
N+7	0	3	1	0	← First data link status word: IR 310
N+8	0	0	0	7	} ← Participating nodes: #1, #2, and #3
N+9	0	0	0	0	
N-10	0	0	0	0	
N+11	0	0	0	0	

Data Link Areas Created

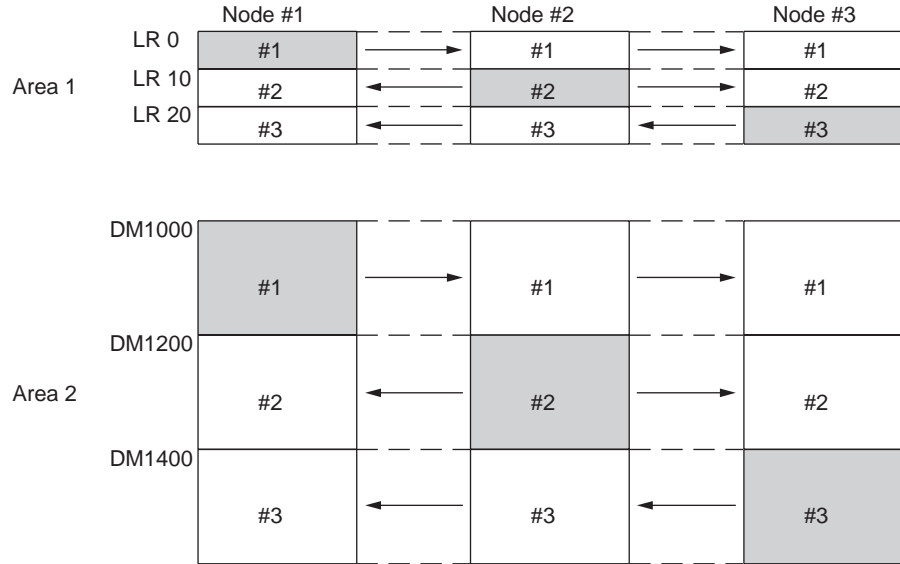

DM Parameter Setting Example for 1:N Allocation, Common Type

When automatic data link creation with common type 1:N allocations is used, the DM parameters area of the startup node is set as follows:

Word	Setting	
N	0050	← Data link mode: Automatic 1:N allocations
N+1 to N+11	0000	← "0" because equality layout allocations are not used.
N+12	0001	← Common type
N+13	0100	← Area for Area 1: CIO Area
N+14	80 00	Start word: CIO 100
N+15	0030	← Area 1 number of send words for master node: 30
N+16	0020	← Area 1 number of send words per slave node: 20
N+17	1000	← Area for Area 2: DM Area
N+18	82 00	Start word: DM 1000
N+19	0400	← Area 2 number of send words for master node: 400 words
N+20	0200	← Area 2 number of send words per slave node: 200 words
N+21	0000	← Data link status stored in default area (See note.)
N+22	000F	← Data link participating nodes: Node 1, node 2, node 3, and node 4
N+23	0000	
N+24	0000	
N+25	0000	

Note The default area for storing data link status is the Special I/O Unit Area (CIO 1500 + (25 × Controller Link Unit number) +7 to +22).

Data Link Area

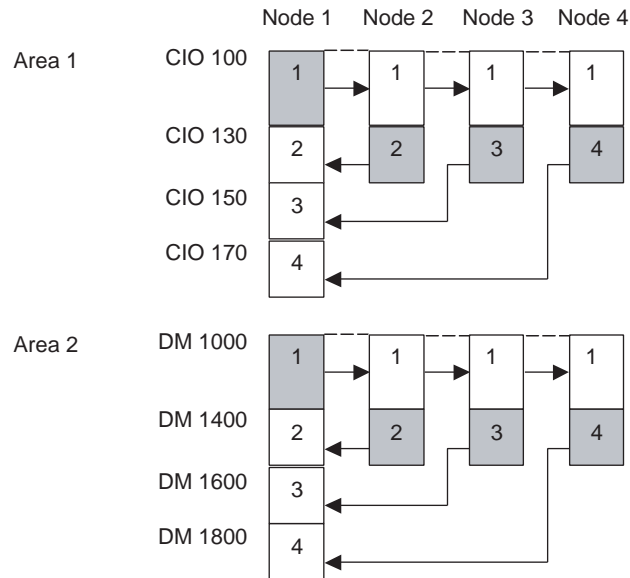

- Note**
1. Node 1 is the master node.
 2. The startup node (the node that sets the above DM parameters and starts the data links) can be set at either a master node or a slave node.

5-3 Starting and Stopping Data Links

Data link must be started after data link areas have been created. Use any of the methods described below for the startup node to start and stop data links. These methods are the same for both manually and automatically set data links.

- Note** The data link mode (manual setting or automatic setting) and data link method are determined according to the data link setting in the startup node. In the startup node, set a data link table in the case of manual setting and data link automatic setting parameters in the case of automatic setting. If the settings are incorrect, the data link will not start.

 **Caution**

1. Check the following items before starting data links. If incorrect data link tables or parameters are set, injury may result due to unexpected operation of the system. Even if the correct data link tables and parameters have been set, do not start or stop data links before verifying that there will be no adverse influence on the system.
 - **Manually Set Data Links**
Check the data link tables in each node participating in the data link to see that they are correct.
Be sure that data link tables are deleted from nodes that are not participating in the data links.
 - **Automatically Set Data Links**
Be sure that the correct DM parameters have been set in the data link startup node.

- In CS1D Systems with Controller Link Units used in duplex operation, set the duplex node as a startup node for data links (Data Link Start/Stop Bit in the CS1D System CPU Unit is turned ON). If the duplex node is not set to be a startup node for data links (Data Link Start/Stop Bit in the CS1D System CPU Unit is OFF), and the relevant node is operating as a polling node, the network's data links may stop if an ACT/STB (active/standby) switchover error occurs.

5-3-1 Using a Programming Device or the User Program

Set the software switch (AR or DM Start Bit) in the PLC to ON using a Programming Device or from the user program.

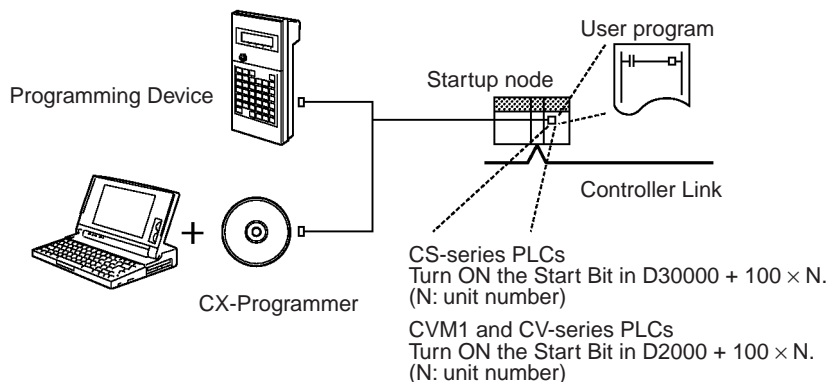

The data links will start when the Start Bit changes from OFF to ON or is already ON when power is turned on. The data links will stop when the Start Bit changes from ON to OFF.

Note The data in the AR and DM Areas is retained when power is turned off. Therefore, by setting in the AR and DM Areas can be made in advance to start data links as soon as power is turned on.

It is recommended to set the Start Bit to ON in multiple nodes that are participating in the data link so that the data links will start even if the startup node is down. The same data link settings must be set in these nodes for automatically set data links.

CS-series Start Bit

	15	14	13	12	11	10	9	8	7	6	5	4	3	2	1	0
Word N	-	-	0	0	0	0	-	-	-	-	-	-	0	0	0	0

N: D30000 + 100 × (unit number)

0: Always set to 0.
-: Other settings

↑ Data link Start Bit
Start: Changed from OFF to ON or set to ON when power is turned on
Stop: Changed from ON to OFF

CVM1 and CV-series Start Bit

	15	14	13	12	11	10	9	8	7	6	5	4	3	2	1	0
Word N	-	-	0	0	0	0	-	-	-	0	-	-	0	0	0	0

N: D2000 + 100 × (unit number)

0: Always set to 0.
-: Other settings

↑ Data link Start Bit
Start: Changed from OFF to ON or set to ON when power is turned on
Stop: Changed from ON to OFF

Note In CS1D Systems with Controller Link Units used in duplex operation, set the duplex node as a startup node for data links (Data Link Start/Stop Bit in the CS1D System CPU Unit is turned ON). If the duplex node is not set to be a

startup node for data links (Data Link Start/Stop Bit in the CS1D System CPU Unit is OFF), and the relevant node is operating as a polling node, the network's data links may stop if an ACT/STB (active/standby) switchover error occurs.

5-3-2 Using the Controller Link Support Software (Ver. 2.00 or Later) and CX-Programmer

Data links can be started or stopped using commands on the Data Link Menu of the Controller Link Support Software (Ver. 2.00). The node for which starting and stopping is being specified must participate in the data links.

Using a Programming Device Connected to PLC Node

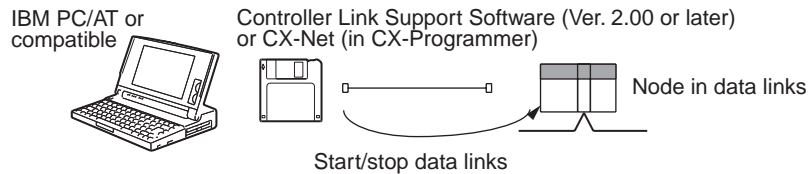

Note Use the CX-Net (in CX-Programmer).

Using a Computer Node

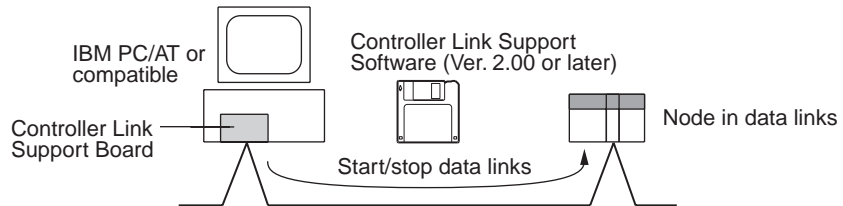

Data links can be started or stopped from the Controller Link Support Board on the local node.

5-3-3 Using FINS Commands

Data links can be started and stopped by sending the RUN and STOP FINS commands from a node on the Controller Link to a node that is in the data links.

Issuing the FINS Command from a Computer Node



Issuing the FINS Command from CVM1, CV-series, and CS-series



Data links can be stopped by sending the FINS command "STOP." The node to which the FINS command is issued must be participating in the data link.

5-4 Checking Data Link Status

There are two methods for checking the status of active data links:

- Check the LED indicators on the front of the Units.
- Check the data link status area.

When using Controller Link Units in duplex operation, check the data link operating status at the active Controller Link Unit. For details on checking the operating status for duplex operation, refer to *10-6-2 Troubleshooting for Duplex Systems Using Indicators*.

5-4-1 LED Indicators

Check the LNK, M/A, and RING indicators on the front of the unit.

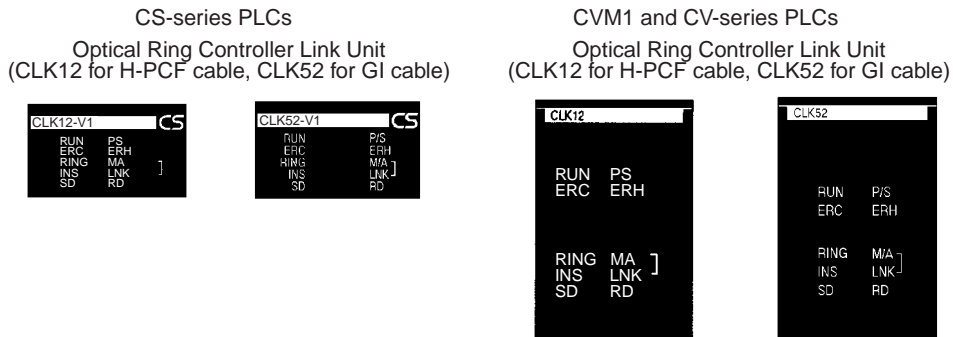

Make sure that the LNK indicator is ON at nodes participating in the active data links. →

Name	Color	Status	Contents	
LNK (data link)	Yellow	ON	Participating in data links.	
		Flashing	Data link table setting error	
		OFF	Not in data links or data links are inactive.	
M/A (data link mode)	Yellow		Data links active in network.	Data links not active in network.
		ON	Manual	Note: This indicator will always be OFF when the data links are not active.
		OFF	Automatic	
RING (transmission path format)	Yellow	ON	Token-ring mode setting (cable normal)	
		Flashing	Token-ring mode setting (cable disconnected)	
		OFF	Token-bus mode setting	

The LNK indicator will be lit at all nodes participating in the data links as long as operation is normal. The mode (manual/automatic) of any node active in the network can be checked using the M/A indicator, regardless of whether that node is participating in the data links. Using the RING indicator, it is also possible to check the transmission path format set for an active network, as well as the status of cables when in token-ring mode. See *10-1 Troubleshooting Using Indicators* for details.

5-4-2 Data Link Status Area

The data link status area can be used to check for errors when data link does not operate normally even though no abnormality has been detected by the PLC's CPU Unit or the Controller Link Unit. The data link status area contains the data link status information shown below. This status information is stored in the same words for CS-series, CVM1, and CV-series.

The number of words used for data link status, and the information that is reflected, depends on the setting (8-bit or 4-bit format) for the data link status storage format specification in the DM parameters area, as shown in the following diagram.

See 10-2 Status Area and Troubleshooting for troubleshooting procedures and see 5-4-3 Data Link Status Storage Format for details on storage format.

When 8-bit Format is Specified (See note 1.)

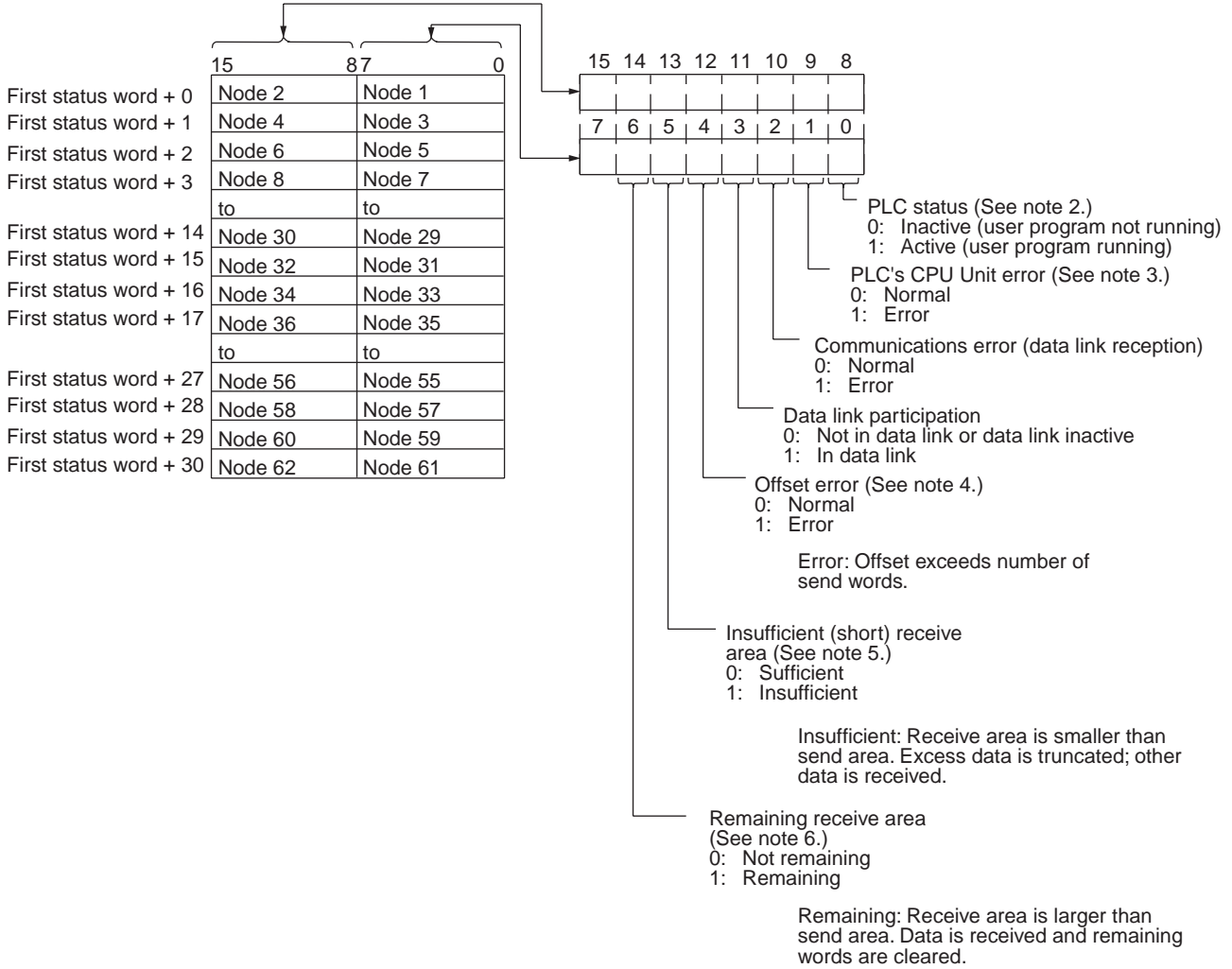

- Note**
1. The default setting for the data link status area is the CIO Area, with CIO 000 as the first data link status storage word. When the default setting is used for the data link status storage destination, 16 words are determined within the status area according to the unit number setting. When the 8-bit format is specified, therefore, the data that is reflected will be limited to node addresses 1 to 32.

When data link status is required for node addresses 33 or larger, do not use the default setting, i.e., specify the first word of the status storage area. If this is done when an 8-bit format is specified, 31 words will be used as the status storage area.
 2. Always 1 for the Controller Link Support Board.
 3. Always 0 for the Controller Link Support Board.

4. Even if an offset error occurs, the data link will operate and the node will participate in the data links. In the node where the offset error occurred, however, all receive area words will be cleared to 0.
5. The following shows an example of an insufficient (short) receive area.

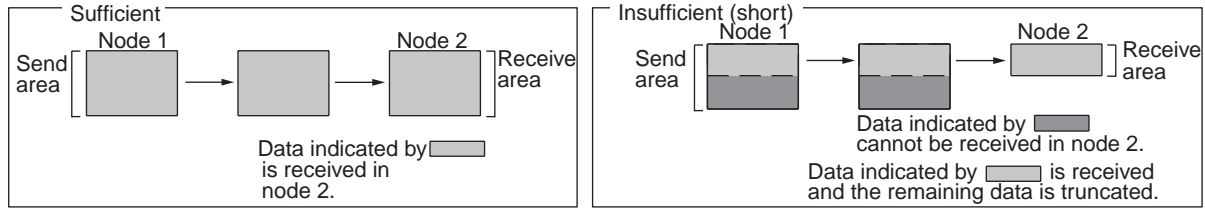

6. The following shows an example of a remaining receive area.

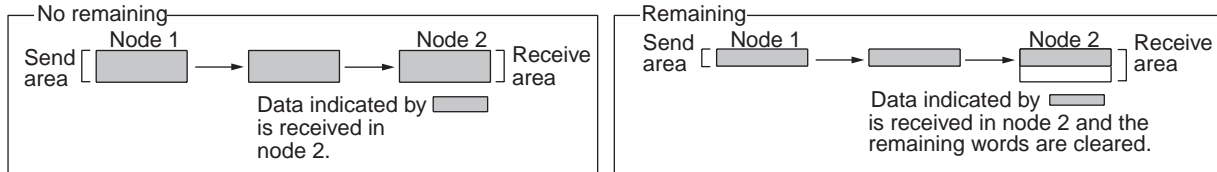

When 4-bit Format is Specified

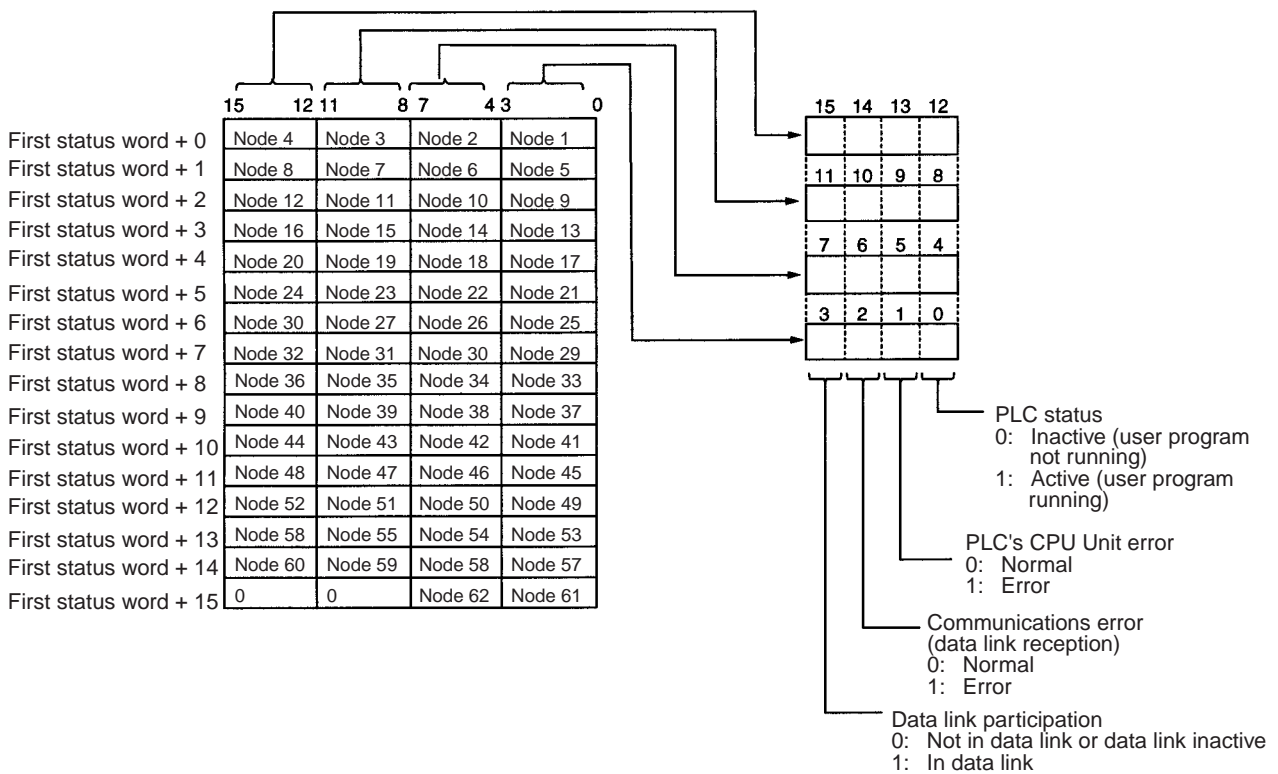

- Note**
1. A communications error will occur in a node that is not participating in the network.
 2. When a communications error occurs, previous status is retained for other nodes status.
 3. Only the PLC status and the PLC's CPU Unit error status are refreshed for nodes that are participating in the network, but not participating in the data links.

- When the data link status area is set in the CIO or LR Area, the data link status will be instantaneously set to 0 when the mode of the PLC's CPU Unit is changed.

The flags in the data link status operate as follows:

Name	Function
Data link participation	The corresponding flag will turn ON if the node has never participated in the data link normally. The flag will not turn OFF once it has turned ON even if the node is no longer participating in the data links.
Communications error	The corresponding flag will turn ON if continuous data link data cannot be received from the node, e.g., due to a cable break. The flag will turn OFF again if data is received from the node normally. The local node's Communications Error Flag will be ON if the local node is isolated from the network.
PLC's CPU Unit error	The corresponding flag will turn ON if the CPU Unit has a fatal error, non-fatal error, or watchdog timer error. The flag will turn OFF again if the node returns to normal. The status of this flag is based on data sent from the node and will not turn ON if data cannot be received, e.g., due to a Communications Error. Make sure that the Communications Error Flag is OFF before checking this flag.
PLC status	The corresponding flag will turn ON if the user program is being executed in the CPU Unit. It will turn OFF if the user program is not being executed. The status of this flag is based on data sent from the node and will not turn ON if data cannot be received, e.g., due to a Communications Error. Make sure that the Communications Error Flag is OFF before checking this flag.

The Data Link Participation Flag and the PLC Status Flag can be used to see if the system has started normally. These flags, however, cannot be used to detect communications errors. Use the Communications Error Flag and PLC's CPU Unit Error Flag to detect errors.

If the Local Node Data Link Participation Flag is OFF, the previous status will be maintained as the data link status and may not be correct. Make sure that the Local Node Data Link Participation Flag is ON before checking data link status.

Note The following Local Node Data Link Participation Flags are available.

CS-series, CVM1, CV-series PLCs:
 Bit 15 in 1500 + 25 x unit number + 6

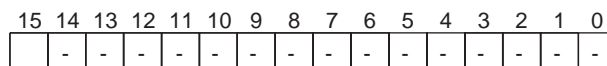

↑ 1: Local node participating in data link.
 0: Local node not participating in data link or data link stopped.

The data link status is enabled only when the local node is participating normally in the network. Make sure that the Local Node Data Link Participation Flag is ON before checking data link status.

The data link status storage area is set as follows:

Data link mode	PLC and operating level	First data link status word	Setting range	Default status
Automatic	CS-series PLC	Specify in DM 30000 + 100 × N + 7	16 or 31 words between CIO 000 and 6640	CIO 1500 + 25 × N + 7 to 22
	CVM1 or CV-series PLC	Specify in DM 2000 + 100 × N + 7	16 or 31 words between CIO 000 and 2540	CIO 1500 + 25 × N + 7 to 22

Data link mode	PLC and operating level	First data link status word	Setting range	Default status
Manual	CS-series PLC	Specify in the data link tables	16 words in the following ranges CIO: 0 to 6640 LR: 0 to 184 DM: 0 to 32752 EM: 0 to 32752	CIO 1500 + 25 × N + 7 to 22
	CVM1 or CV-series PLC		16 or 31 words in the following ranges CIO: 0 to 2540 LR: 0 to 184 DM: 0 to 24560 EM: 0 to 32750	

Note N: Unit number

5-4-3 Data Link Status Storage Format

Either an 8-bit or 4-bit format can be set as the method for storing the data link status. The format setting can be made separately for each node.

- This setting determines the number of words to be used for data link status, and also the information to be reflected. (Refer to 5-4-2 Data Link Status Area.)
- When the 8-bit format is set, the data link status area will be 31 words, and when the 4-bit format is set it will be 16 words. When the default setting is used for the data link status storage destination, however, this area is always 16 words regardless of the data link status storage format. Even when the 8-bit format is specified, therefore, the data link status that is actually reflected will be limited to node addresses 1 to 32.

The settings for the data link status storage format are shown below. The setting is made using the software switch in bit 7 of the DM parameters area. The address of the software switch will vary depending on the PLC, as follows:

- CS-series Optical Ring Controller Link Units: DM 30000 + 100 x unit number
- CVM1/CV-series Optical Ring Controller Link Units: DM 2000 + 100 x unit number

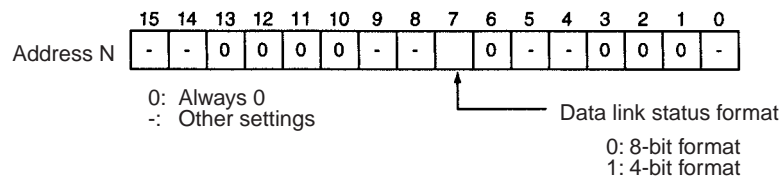

- This setting cannot be made for Optical Bus Controller Link Units (CLK11), because it is fixed at the 8-bit format. Always specify 0. With Optical Bus, the nodes for data links are limited to node addresses 1 to 32, so the data link status is always 16 words.
- The data link status is enabled only when the local node is participating normally in the data links. Confirm that the Local Node Data Link Participating Bit is ON before checking the data link status.

Note The data link storage format setting is enabled with the data link startup node setting. Therefore, if multiple nodes are set as startup nodes, ensure that they all have the same settings. If there are different settings, the format setting will depend on the startup node.

5-4-4 Checking by Manipulating Bit/Word Status

After you have confirmed that the data link function is operating normally, check to see whether or not the data link is operating as intended, i.e., check to see if the desired bits/words data is being transferred to the intended words at other nodes.

Although the data link function itself may be operating correctly, the data link areas may have been input incorrectly.

Change the contents of a bit or word in a data link send area using a Programming Device or the user program and check whether the change is reflected in data link areas of other nodes as intended.

Note Do not restart the polling node of the Controller Link Network while data links are active. Otherwise, the data links may stop.

5-4-5 Error Detection Program Example

Setting the Data Link Status Storage Format

The data link status storage method can be set to either 8-bit format or 4-bit format. The same data link status storage format is used by all nodes participating in the data link, according to the setting of the data link startup node.

- The words used for the data link status and the information shown in the status area are determined by the data link status storage format setting (refer to page 117).
- When 8-bit format is set, 31 words are allocated for data link status, and in 4-bit format, 16 words are allocated. When the default setting is used as the data link status storage destination, however, the allocation for data link status is always 16 words, regardless of the data link status storage format specification. Therefore, even when 8-bit format is specified, the actual data link status shown will be for node addresses 1 to 32 only.

The data link status storage format specification is made using the software switch in bit 7 of the DM parameters area.

The address of the software switch is as follows:

- CS-series Optical Ring Controller Link Units: DM 30000 + 100 × unit number
- CVM1 and CV-series Optical Ring Controller Link Units: DM 2000 + 100 × unit number

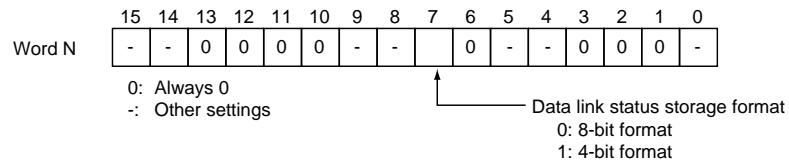

- The data link status storage format for optical models (model numbers with the suffix CLK11) is fixed to 8-bit format, so it cannot be set. If Optical Ring Controller Link Units or Optical Bus Controller Link Units will be used in the network, always set the data link status storage format to 0. The nodes that can participate in the data link are limited to nodes with node addresses 1 to 32, and the data link status is always 16 words.
- The data link status is enabled only when the local node is participating normally in the data links. Make sure that the Local Node Data Link Participation Flag is ON before checking the data link status.

Note The network uses the data link storage format setting that is set in the startup node. Therefore, if multiple nodes are set as startup nodes, make sure that they all have the same settings. If the settings are different in each startup node, the data link storage format setting used will depend on the startup node.

Error Detection Programming Examples

The following examples show programming using data link statuses.

Using Data Link Communications Processing to Detect Normal Operation or Errors in Other Nodes

- The data link status is enabled when the local node is participating normally in the data links.
- When the local node is participating in the data links, an AND condition of the data link status for each node can be taken using the Communications Error Flag and Data Link Participation Flag to detect errors and output them.
- The Communications Error Flag will be ON for nodes that are not participating in the network or nodes in which a communications error has occurred.
- The Data Link Participation Flag will remain OFF in nodes that cannot participate in the data links due to an error occurring while the data link is active.

The following programming can be used to check whether the data link communications are normal at system startup.

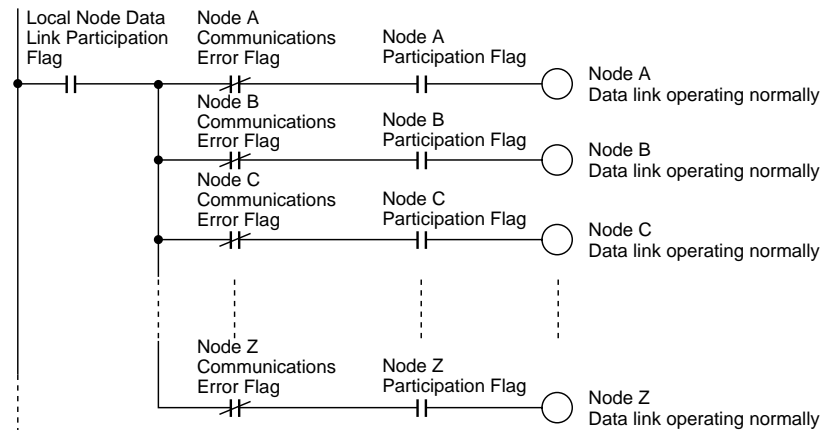

The following programming can be used to detect errors in data link communications while the system is operating (after the data link has started up normally for all nodes, this programming can be used to detect any new errors that occur).

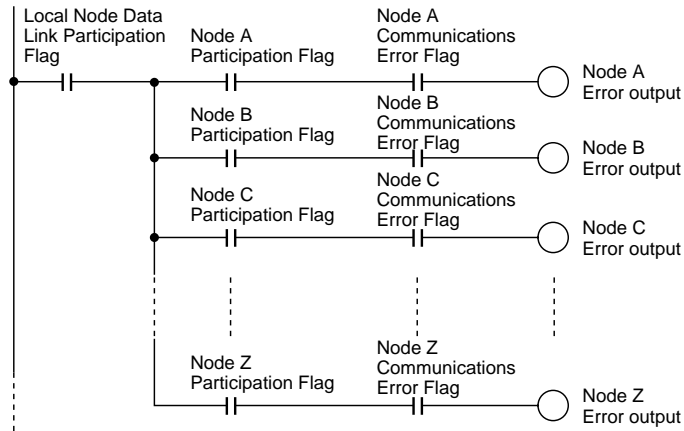

Data Link Error Detection in Local Node

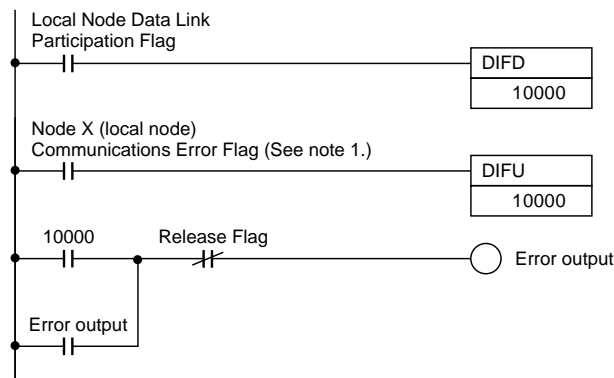

- Note**
1. The Communications Error Flag (in the data link status area) for the local node, which monitors data link status, will be set to ON if the local node is isolated from the network while the data link is active. In this case, the data link remains active, so the node's Data Link Participation Flag will remain ON even though the node is isolated from the network.
 2. In a SYSMAC LINK network, the local node's Local Node Data Link Participation Flag will be set to OFF if the local node is isolated from the network. In a Controller Link network, the local node's Local Node Data Link Participation Flag will remain ON, but the Communications Error Flag for the local node will be set to ON in the data link status area.

Programming Examples for Processing Data when Errors Occur

If a communications error occurs in a data link and valid data link data cannot be received, the previous data is stored in the data link area. To stop processing using the data link data when an error occurs, refer to the following programming example.

Processing Data Only when Data Links Are Operating Normally

Perform processing only when the data links are operating normally by including an AND condition for the Data Link Normal Operation Flag in the part of the programming that handles data link data for each node. This is an example of programming locks in the appropriate places.

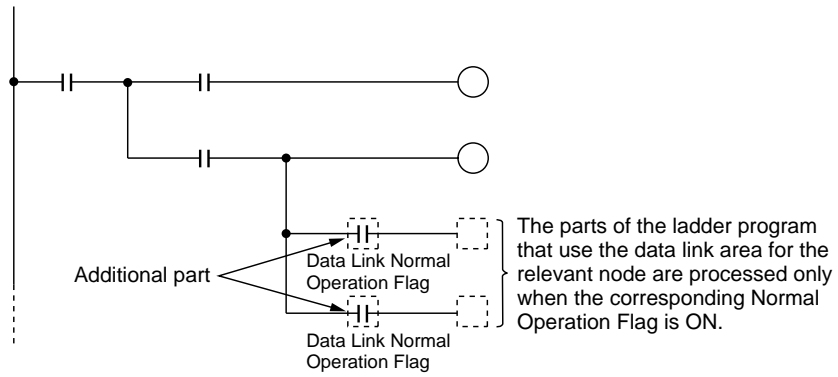

Data Link Normal Operation Flags can be created using the programming described in *Using Data Link Communications Processing to Detect Normal Operation or Errors in Other Nodes* on page 136.

Processing Data Only when Operation Is Normal Using the IL-ILC and JMP-JME Instructions

Perform processing only when operation is normal by creating a program based on program blocks that process data for each node with the IL-ILC and JMP-JME programs.

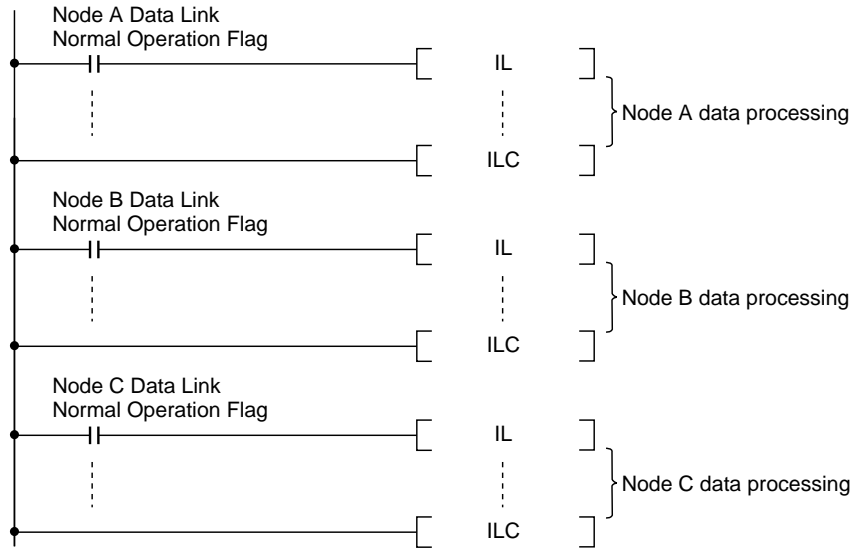

Data Link Normal Operation Flags can be created using the programming described in *Using Data Link Communications Processing to Detect Normal Operation or Errors in Other Nodes* on page 136.

Writing 0000 in the Data Link Area when Errors Occur

When data links are not operating normally, write 0000 to the data link area of the node with the error to stop other data being received.

The following example shows how to write 0000 in the data link area of node 2 (D00100 to D00120) using the BSET(071) (block set) instruction when an error occurs at node 2.

Data Link Example: Communications Error at Node 2

Node 1		Node 2		Node 62
#1		#1		#1
#2	x ←	#2		#2
#62		#62		#62

Example of Programming for Node 1 to Handle Communications Errors at Node 2

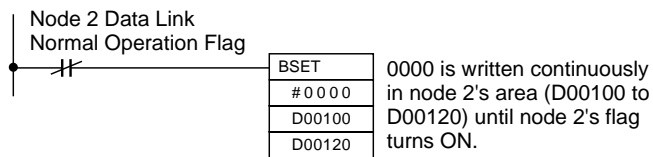

Insert the above programming at the start of the program.

Data Link Normal Operation Flags can be created using the programming described in *Using Data Link Communications Processing to Detect Normal Operation or Errors in Other Nodes* on page 136.

- Note**
1. If an error occurs and 0000 is written to the Data Link Area occurs for an unstable transmission path (i.e., one that repeatedly alternates between communications errors and normal operation), the normal data will be frequently cleared to 0000. Data processing methods that will not process data or arithmetic operations when errors occur are recommended (such as shown in the example for processing data only when data links are operating normally or the example for processing data only when operation is normal using the IL-ILC and JMP-JME instructions).
 2. The BSET(071) instruction is used to write 0000 to the corresponding area in which the ladder program is executing, but the value in the data link table will be read if the words are being monitored from Support Software. This enables peripheral servicing (i.e., for Support Software) to be executed after the CPU Unit has performed I/O refreshing (Controller Link Unit data link refresh).
 3. With Controller Link data links, if there is an error at the remote node (source node), the previous data (i.e., data received immediately before the error) continues to be stored in the data link receive area of the node receiving the data. To clear the data in the receive area to 0 when an error occurs, refer to the above example and include the appropriate programming for clearing to 0.
 4. Refresh processing for the data used in Controller Link data links is performed between the Controller Link Unit and CPU Unit with every cycle. Therefore, the above programming must be included at the start of the program. This method of clearing to 0 can be used with CS1, and CS1-H CPU Units as long as the DLNK(226) instruction is not used, and can be used with CVM1/CV CPU Units as long as CPU execution processing is set to synchronous processing. It cannot be used with CS1-H CPU Units if the DLNK(226) instruction is used, or with CVM1/CV CPU Units if CPU execution processing is set to asynchronous processing. (This is because when the DLNK(226) instruction is used with CS1-H CPU Units, or when asynchronous processing is set for the CVM1/CV CPU Units, the refreshing of data for data links is not synchronized with the instruction execution cycle.)

SECTION 6

Message Service

This section explains how to use the message service provided by a Controller Link Unit. It also explains the FINS commands and responses supported by Controller Link Units and those supported by CS-series, CVM1 and CV-series PLCs.

6-1	Introduction	142
6-1-1	SEND and RECV	143
6-1-2	CMND	147
6-1-3	Send/Receive Data Areas	150
6-2	Selecting Communications Instructions	152
6-2-1	Message Service Operations	153
6-2-2	Message Service Specifications	153
6-3	Using the Message Service	154
6-4	FINS Commands and Responses	160
6-4-1	FINS Communications Service	160
6-4-2	Sending and Receiving FINS Commands and Responses	160
6-4-3	Applicable Units for FINS Commands	162
6-5	Commands and Responses for Controller Link Units	162
6-5-1	Command Codes	162
6-5-2	DATA LINK START	163
6-5-3	DATA LINK STOP	163
6-5-4	CONTROLLER DATA READ	163
6-5-5	CONTROLLER STATUS READ	164
6-5-6	NETWORK STATUS READ	166
6-5-7	DATA LINK STATUS READ	168
6-5-8	CONNECTION DATA READ	169
6-5-9	NETWORK DISCONNECT DATA READ	171
6-5-10	NETWORK DISCONNECT DATA CLEAR	173
6-5-11	ECHOBACK TEST	174
6-5-12	BROADCAST TEST RESULTS READ	174
6-5-13	BROADCAST TEST DATA SEND	175
6-5-14	ERROR LOG READ	175
6-5-15	ERROR LOG CLEAR	176
6-6	Response Codes	177
6-6-1	Configuration	177
6-6-2	Network Relay Errors	177
6-6-3	Response Codes and Troubleshooting	179

6-1 Introduction

A message service is a command/response system used for data transmission between nodes on a network, i.e., PLC to PLC, PLC to computer, and computer to PLC). The message service can also be used to control operations, such as mode changes. The message service is implemented by sending commands from the user program. The following communications instructions are used:

SEND and RECV: Instructions for sending and receiving data.

CMND: An instruction for sending FINS commands. Some FINS commands are supported by Controller Link Units, and other FINS commands supported by the PLC's CPU Unit.

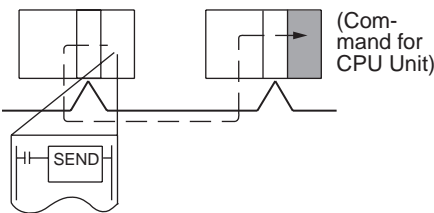
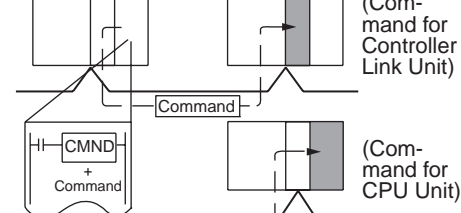
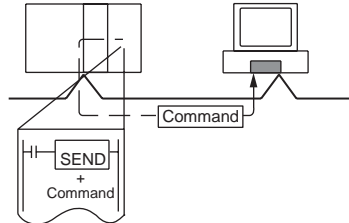
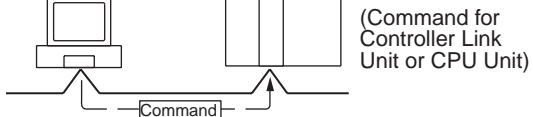
Message service	SEND/RECV instructions	CMND instruction (FINS commands)
Local node to remote node	<p>PLC to PLC</p> <p>CS-series, CVM1, or CV-series PLC CS-series, CVM1, or CV-series PLC</p>  <p>User program</p> <p>A program is not required for receiving responses when the PLC executes SEND and RECV.</p>	<p>CS-series, CVM1, or CV-series PLC CS-series, CVM1, or CV-series PLC</p>  <p>User program</p> <p>A program is not required for receiving responses when the PLC executes commands.</p>
PLC to computer	<p>CS-series, CVM1, or CV-series PLC Computer</p>  <p>A program is required for sending and receiving data with the computer.</p> <p>A program is not required for receiving responses when the PLC executes commands.</p>	
Computer to PLC	<p>Computer CS-series, CVM1, or CV-series PLC</p> <p>(The equivalent of SEND/RECV and CMND are sent from the computer program.)</p>  <p>Programming is required to receive responses at the computer.</p>	
Local node: Remote node	<p>SEND: 1:1 or 1:N (broadcast) There are no responses for broadcasting.</p> <p>RECV: 1:1</p>	<p>1:1 or 1:N (broadcast) There are no responses for broadcasting.</p>
Data length	1,980 bytes max. (990 words)	1,990 bytes max.

6-1-1 SEND and RECV

I/O memory data from other nodes can be read or written by simply using the program in the CPU Unit of a CS-series, CVM1, or CV-series PLC to execute SEND and RECV.

CS-series PLCs

SEND

SEND transmits “n” words beginning with S (the beginning word for data transmission at the local node) to “n” words beginning with D (the beginning word for data reception at the remote node, N.)

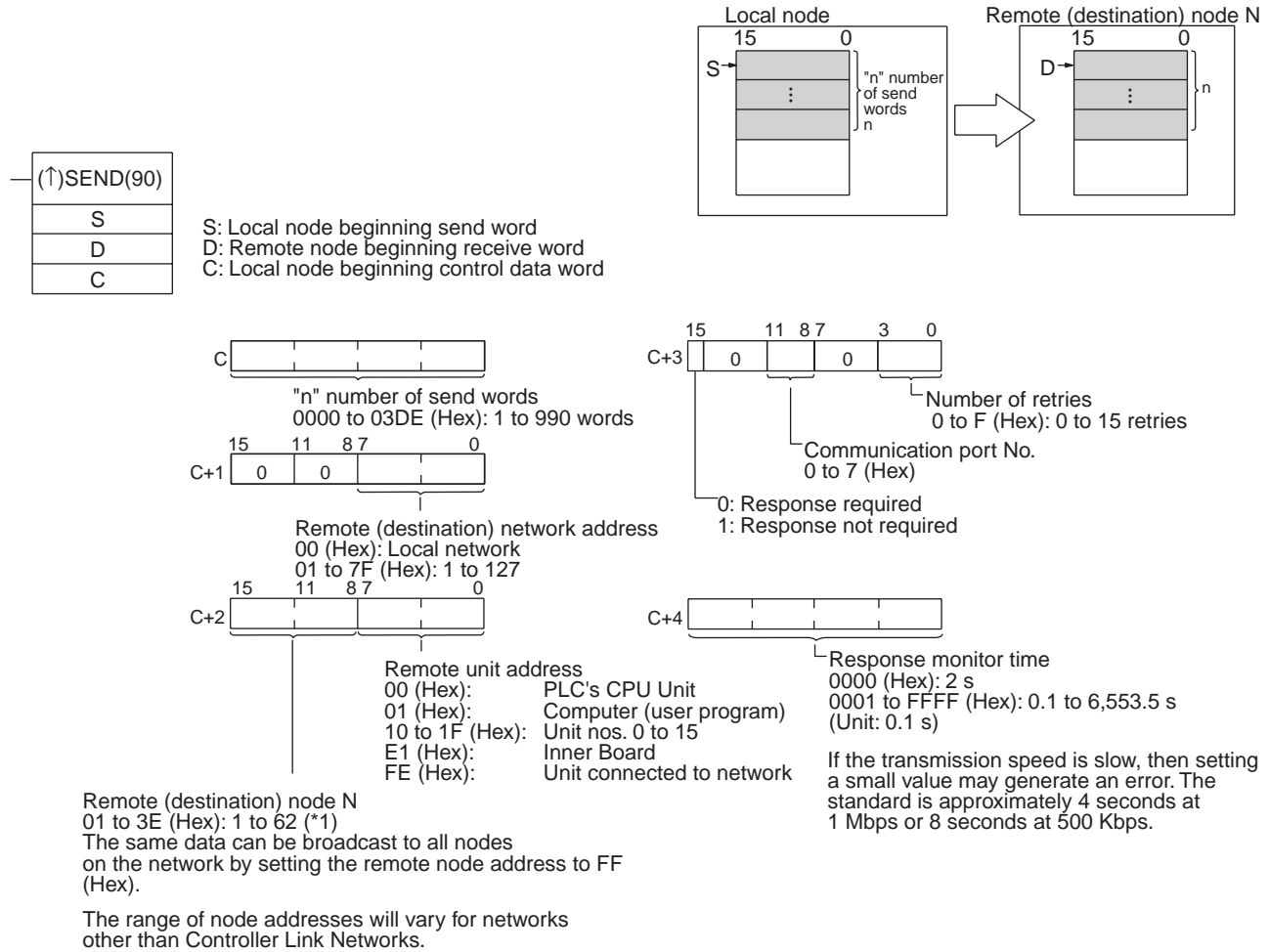

- Note**
1. When communicating with a CVM1 or CV-series PLC manufactured prior to April 1996 on the local network, the local network address cannot be set to “00.” Set a number other than “00” as the local network address in the routing tables, and then specify that number.
 2. With the message service, there is no guarantee that a message to a remote node will reach its destination. It is always possible that the message may be lost in transit due to noise or some other condition. When using the message service, it is advisable to prevent this situation from occurring by performing resend processing at the node where instructions are issued. With the SEND, RECV, and CMND instructions, resend processing is performed automatically once the number of retries has been set, so be sure to specify a number other than “0” for the number of retries.

- If the total number of data link words is increased, the communications cycle time will be increased. This may cause timeout errors to occur when waiting for the response. In that case, lengthen the response monitor time (control data word C+4).

RECV

RECV receives “m” words beginning with S (the beginning word for data transmission at the remote node, M) to the words beginning with D (the beginning word for data reception at the local node).

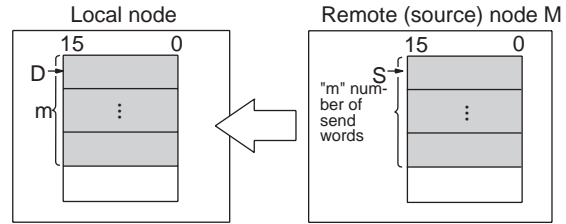

(↑)RECV(98)
S
D
C

S: Remote node beginning send word
 D: Local node beginning receive word
 C: Local node beginning control data word

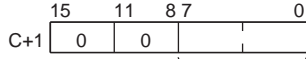
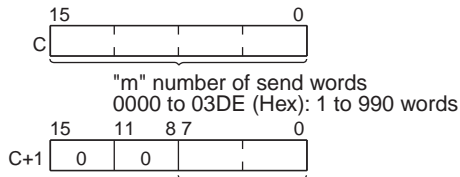

Remote (source) network address
 00 (Hex): Local network
 01 to 7F (Hex): 1 to 127

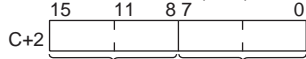

Remote unit address
 00 (Hex): PLC's CPU Unit
 01 (Hex): Computer (user program)
 10 to 1F (Hex): Unit nos. 0 to 15
 E1 (Hex): Inner Board
 FE (Hex): Unit connected to network

Remote (source) node M
 01 to 3E (Hex): 1 to 62 (*1)

The range of node addresses will vary for networks other than Controller Link Networks.

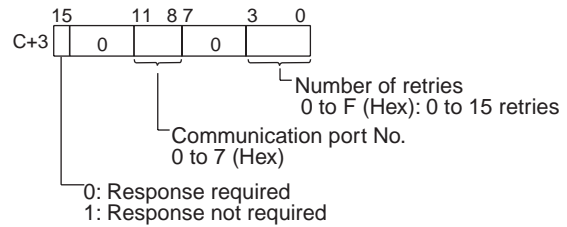

Response monitor time
 0000 (Hex): 2 s
 0001 to FFFF (Hex): 0.1 to 6,553.5 s (Unit: 0.1 s)

If the transmission speed is slow, then setting a small value may generate an error. The standard is approximately 4 seconds at 1 Mbps or 8 seconds at 500 Kbps.

*1 Only node addresses 1 to 32 can be specified when Optical Bus Controller Link Units/Boards (CLK11) are combined in a network with Optical Ring Controller Link Units/Boards operating in token-bus mode.

- Note**
- When communicating with a CVM1 or CV-series PLC manufactured prior to April 1996 on the local network, the local network address cannot be set to “00.” Set a number other than “00” as the local network address in the routing tables, and then specify that number.
 - With the message service, there is no guarantee that a message to a remote node will reach its destination. It is always possible that the message may be lost in transit due to noise or some other condition. When using the message service, it is advisable to prevent this situation from occurring by performing resend processing at the node where instructions are issued. With the SEND, RECV, and CMND instructions, resend processing is performed automatically once the number of retries has been set, so be sure to specify a number other than “0” for the number of retries.

- If the total number of data link words is increased, the communications cycle time will be increased. This may cause timeout errors to occur when waiting for the response. In that case, lengthen the response monitor time (control data word C+4).

CVM1 and CV-series PLCs

SEND

SEND transmits “n” words beginning with S (the beginning word for data transmission at the local node) to “n” words beginning with D (the beginning word for data reception at the remote node, N.)

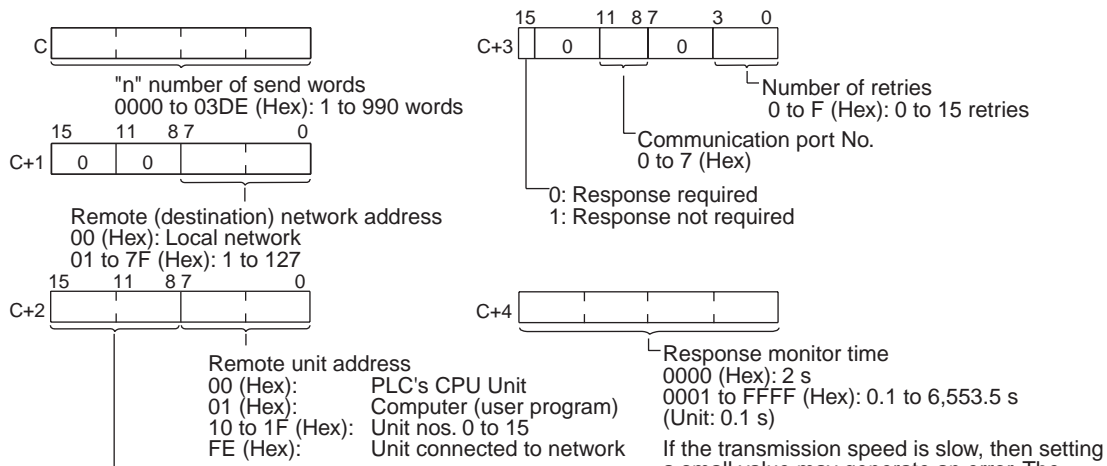
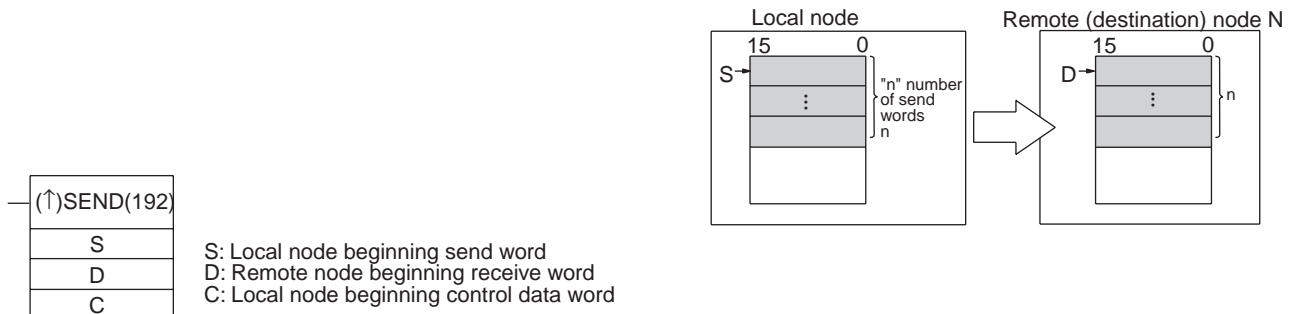

Remote (destination) node N
01 to 3E (Hex): 1 to 62 (*1)
The same data can be broadcast to all nodes on the network by setting the remote node address to FF (Hex).

The range of node addresses will vary for networks other than Controller Link Networks.

*1 Only node addresses 1 to 32 can be specified when Optical Bus Controller Link Units/Boards (CLK11) are combined in a network with Optical Ring Controller Link Units/Boards operating in token-bus mode.

- Note**
- When using CVM1 and CV-series PLCs manufactured prior to April 1996, the local network address cannot be set to “00.” Set a number other than “00” as the local network address in the routing tables, and then specify that number.
 - With the message service, there is no guarantee that a message to a remote node will reach its destination. It is always possible that the message may be lost in transit due to noise or some other condition. When using the message service, it is advisable to prevent this situation from occurring by performing resend processing at the node where instructions are issued. With the SEND, RECV, and CMND instructions, resend processing is performed automatically once the number of retries has been set, so be sure to specify a number other than “0” for the number of retries.

RECV

RECV receives “m” words beginning with S (the beginning word for data transmission at the remote node, M) to the words beginning with D (the beginning word for data reception at the local node).

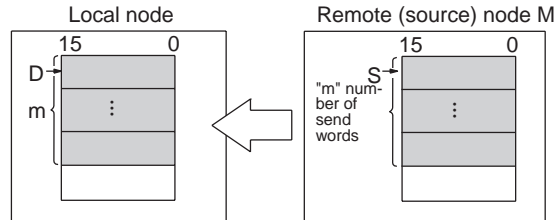

(↑)RECV(193)
S
D
C

S: Remote node beginning send word
 D: Local node beginning receive word
 C: Local node beginning control data word

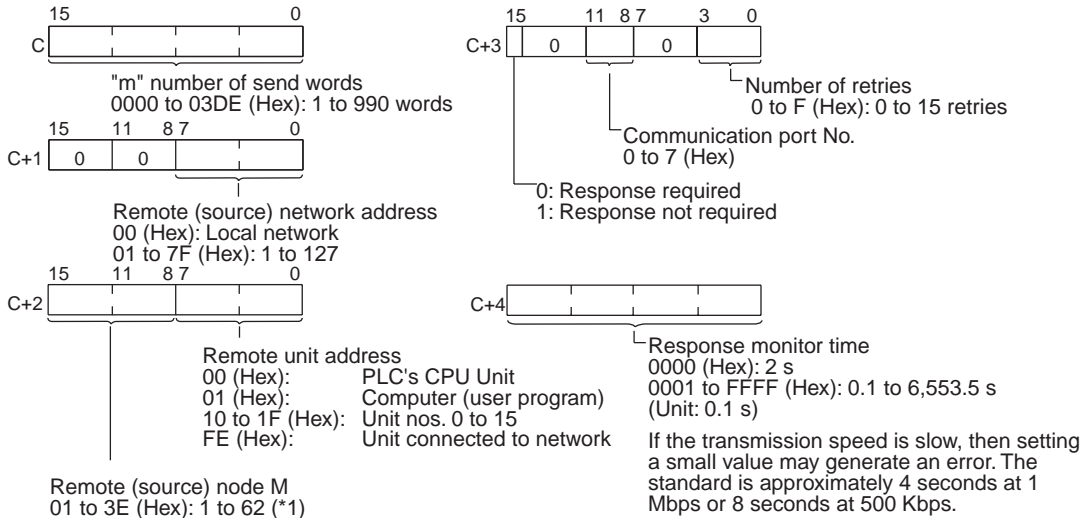

*1 Only node addresses 1 to 32 can be specified when Optical Bus Controller Link Units/Boards (CLK11) are combined in a network with Optical Ring Controller Link Units/Boards operating in token-bus mode.

- Note**
1. When using CVM1 and CV-series PLCs manufactured prior to April 1996, the local network address cannot be set to “00.” Set a number other than “00” as the local network address in the routing tables, and then specify that number.
 2. With the message service, there is no guarantee that a message to a remote node will reach its destination. It is always possible that the message may be lost in transit due to noise or some other condition. When using the message service, it is advisable to prevent this situation from occurring by performing resend processing at the node where instructions are issued. With the SEND, RECV, and CMND instructions, resend processing is performed automatically once the number of retries has been set, so be sure to specify a number other than “0” for the number of retries.

6-1-2 CMND

The CMND instruction can be executed in the user program in a CS-series, CVM1, or CV-series PLC to perform operations such as reading and writing memory data from and to other nodes, reading status information, and changing the operating mode.

CS-series PLCs

CMND(490) sends “n” bytes of command data beginning with S (the beginning word for storing command data at the local node) to remote node N. In return, “m” bytes of response data are stored at the local node beginning with D (the beginning word for storing response data).

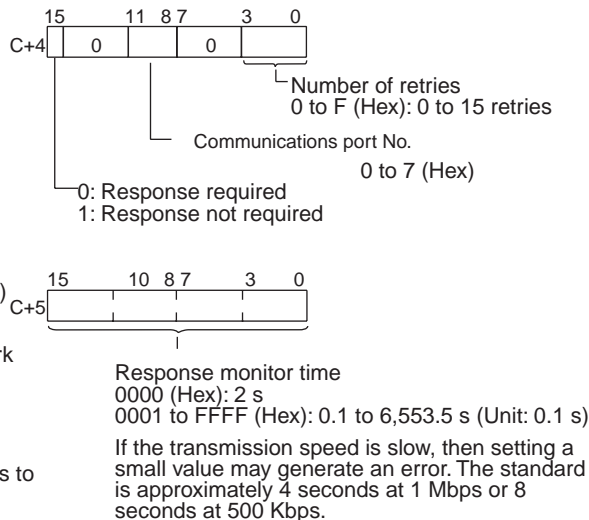
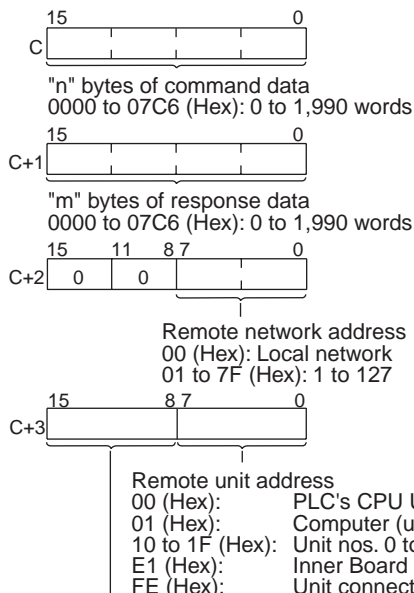
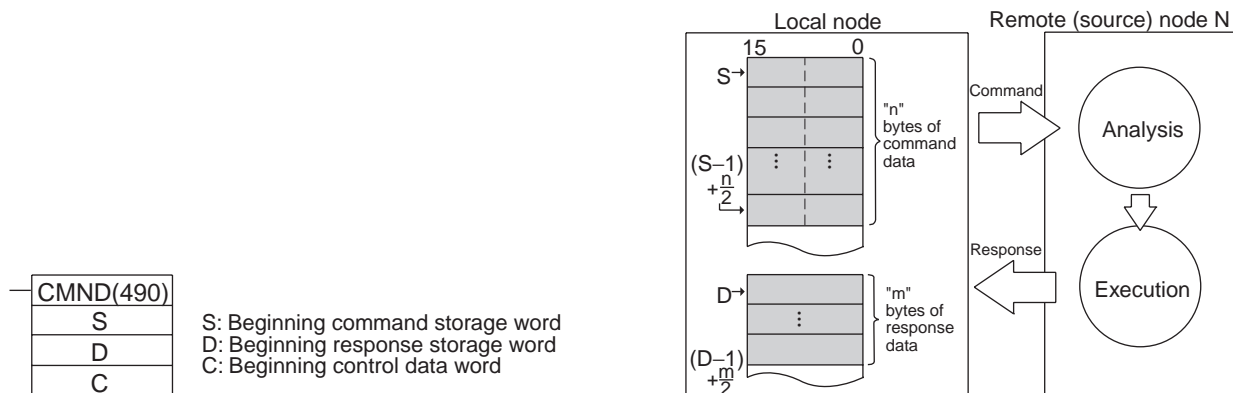

Remote node N
00 to 3E (Hex): 0 to 62 (*1)
The same data can be broadcast to all nodes on the network by setting the remote node address to FF (Hex).

The range of node addresses will vary for networks other than Controller Link Networks.

*1 Only node addresses 1 to 32 can be specified when Optical Bus Controller Link Units/Boards (CLK11) are combined in a network with Optical Ring Controller Link Units/Boards operating in token-bus mode.

Note With the message service, there is no guarantee that a message to a remote node will reach its destination. It is always possible that the message may be lost in transit due to noise or some other condition. When using the message service, it is advisable to prevent this situation from occurring by performing

resend processing at the node where instructions are issued. With the SEND, RECV, and CMND instructions, resend processing is performed automatically once the number of retries has been set, so be sure to specify a number other than "0" for the number of retries.

CVM1 and CV-series PLCs

CMND(194) sends "n" bytes of command data beginning with S (the beginning word for storing command data at the local node) to node N. In return, "m" bytes of response data are stored at the local node beginning with D (the beginning word for storing response data).

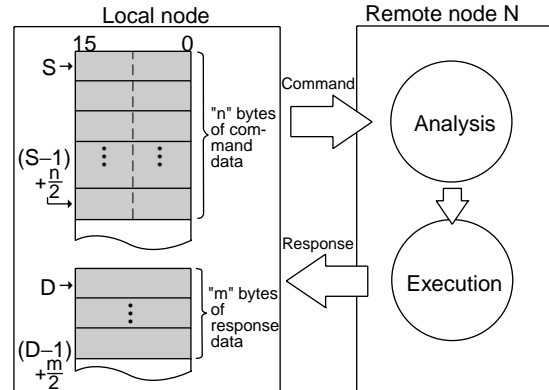

CMND(194)
S
D
C

S: Beginning command storage word
 D: Beginning response storage word
 C: Beginning control data word

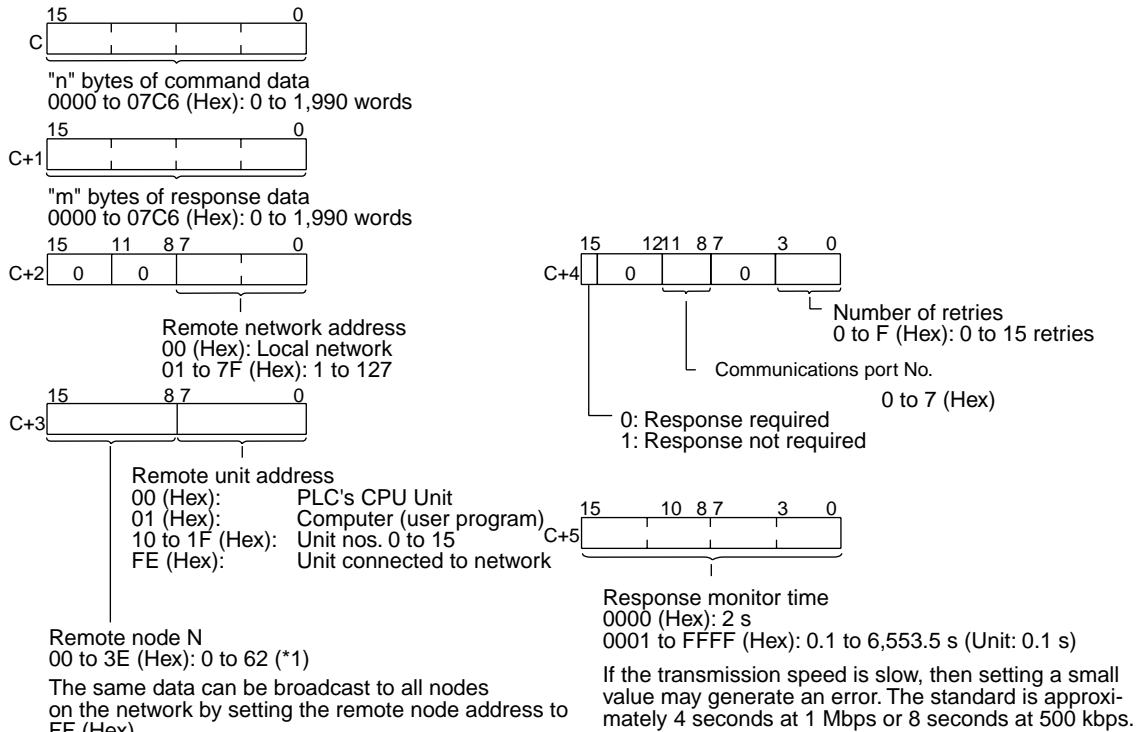

*1 Only node addresses 1 to 32 can be specified when Optical Bus Controller Link Units/Boards (CLK11) are combined in a network with Optical Ring Controller Link Units/Boards operating in token-bus mode.

Note 1. When using CVM1 and CV-series PLCs manufactured prior to April 1996, the local network address cannot be set to "00." Set a number other than "00" as the local network address in the routing tables, and then specify that number.

2. With the message service, there is no guarantee that a message to a remote node will reach its destination. It is always possible that the message may be lost in transit due to noise or some other condition. When using the message service, it is advisable to prevent this situation from occurring by performing resend processing at the node where instructions are issued. With the SEND, RECV, and CMND instructions, resend processing is performed automatically once the number of retries has been set, so be sure to specify a number other than "0" for the number of retries.

Example: Commands for CVM1, CV-series and CS-series PLCs

Type of command		Code	CS	CVM1/ CV
For memory areas (CIO, DM, EM, TC, transition, step, forced ON/OFF)	MEMORY AREA READ	0101	Yes	Yes
	MEMORY AREA WRITE	0102	Yes	Yes
	MEMORY AREA FILL	0103	Yes	Yes
	MULTIPLE MEMORY AREA READ	0104	Yes	Yes
	MEMORY AREA TRANSFER	0105	Yes	Yes
For parameter areas (PLC system setting, I/O table registration, routing table, etc.)	PARAMETER AREA READ	0201	Yes	Yes
	PARAMETER AREA WRITE	0202	Yes	Yes
	PARAMETER AREA CLEAR	0203	Yes	Yes
For program areas (UM)	PROGRAM AREA PROTECT	0304	Yes	Yes
	PROGRAM AREA PROTECT CLEAR	0305	Yes	Yes
	PROGRAM AREA READ	0306	Yes	Yes
	PROGRAM AREA WRITE	0307	Yes	Yes
	PROGRAM AREA CLEAR	0308	Yes	Yes
PLC mode	RUN	0401	Yes	Yes
	STOP	0402	Yes	Yes
PLC model data	CONTROLLER DATA READ	0501	Yes	Yes
	CONNECTION DATA READ	0502	Yes	Yes
PLC status data	CONTROLLER STATUS READ	0601	Yes	Yes
	CYCLE TIME READ	0620	Yes	Yes
PLC internal clock	CLOCK READ	0701	Yes	Yes
	CLOCK WRITE	0702	Yes	Yes
Messages	MESSAGE READ	0920	Yes	Yes
	MESSAGE CLEAR		Yes	Yes
	FAL/FALS READ		Yes	Yes
Access rights	ACCESS RIGHT ACQUIRE	0C01	Yes	Yes
	ACCESS RIGHT FORCED ACQUIRE	0C02	Yes	Yes
	ACCESS RIGHT RELEASE	0C03	Yes	Yes

Type of command		Code	CS	CVM1/ CV
Error data	ERROR CLEAR	2101	Yes	Yes
	ERROR LOG READ	2102	Yes	Yes
	ERROR LOG CLEAR	2103	Yes	Yes
File Memory	FILE NAME READ	2201	Yes	Yes
	SINGLE FILE READ	2202	Yes	Yes
	SINGLE FILE WRITE	2203	Yes	Yes
	MEMORY CARD FOR- MAT	2204	Yes	Yes
	FILE DELETE	2205	Yes	Yes
	VOLUME LABEL CRE- ATE/DELETE	2206	No	Yes
	FILE COPY	2207	Yes	Yes
	FILE NAME CHANGE	2208	Yes	Yes
	FILE DATA CHECK	2209	No	Yes
	MEMORY AREA FILE TRANSFER	220A	Yes	Yes
	PARAMETER AREA FILE TRANSFER	220B	Yes	Yes
	PROGRAM AREA FILE TRANSFER	220C	Yes	Yes
	Forced set/reset	FORCED SET/RESET	2301	Yes
FORCED SET/RESET CANCEL		2302	Yes	Yes

For details on commands for CS-series PLCs, refer to the *CS/CJ-series Programmable Controllers Communications Commands Reference Manual (W342)*. For details on commands for CVM1 and CV-series PLCs, refer to the *FINS Commands Reference Manual (W227)*.

6-1-3 Send/Receive Data Areas

The data areas that can be used as operands in the SEND and RECV instructions depend on the PLC, as shown in the following tables. Be sure to set the operands so that the end of the data area is not exceeded.

CS-series PLCs

Area	Range
CIO	CIO 0000 to CIO 6143
Work Area (WR)	W000 to W511
Holding Area	H000 to H511
Auxiliary Area	A000 to A959 (See note 1.)
Timer	TIM0000 to TIM4095
Counter	CNT0000 to CNT4095
Data Memory	D00000 to D32767
Extended Data Memory	E00000 to E32767 (See note 2.)

- Note**
1. Writing is not possible to words A000 through A447 in the Auxiliary Area.
 2. A maximum of thirteen banks can be used for Expansion DM. For details on extended data memory and the number of banks, refer to the operation manual for the PLC model that is being used.

CVM1 and CV-series PLCs

Area	Range	
	CV500, CVM1-CPU01	CV1000/2000, CVM1-CPU11/21
CIO Area	0000 to 2555	
CPU Bus Link Area	G000 to G255 (See note 1.)	
Auxiliary Area	A000 to A511 (See note 2.)	
Timer Area	T000 to T511	T000 T1023
Counter Area	C000 to C511	C000 to C1023
DM Area	DM0000 to DM8191	DM0000 to DM24575
Expansion DM Area	---	EM00000 to EM32765 (See note 3.)

- Note**
1. Writing is not possible to words G000 through G007 in the CPU Bus Link Area.
 2. Writing is not possible to words A256 through A511 in the Auxiliary Area.
 3. Expansion DM can be used by mounting an Expansion DM Unit to a CV1000/2000 or CVM1-CPU11/21 PLC. A maximum of eight banks can be used, depending on the type of Expansion DM. For details, refer to the CVM1 and CV-series PLC operation manuals.

6-2 Selecting Communications Instructions

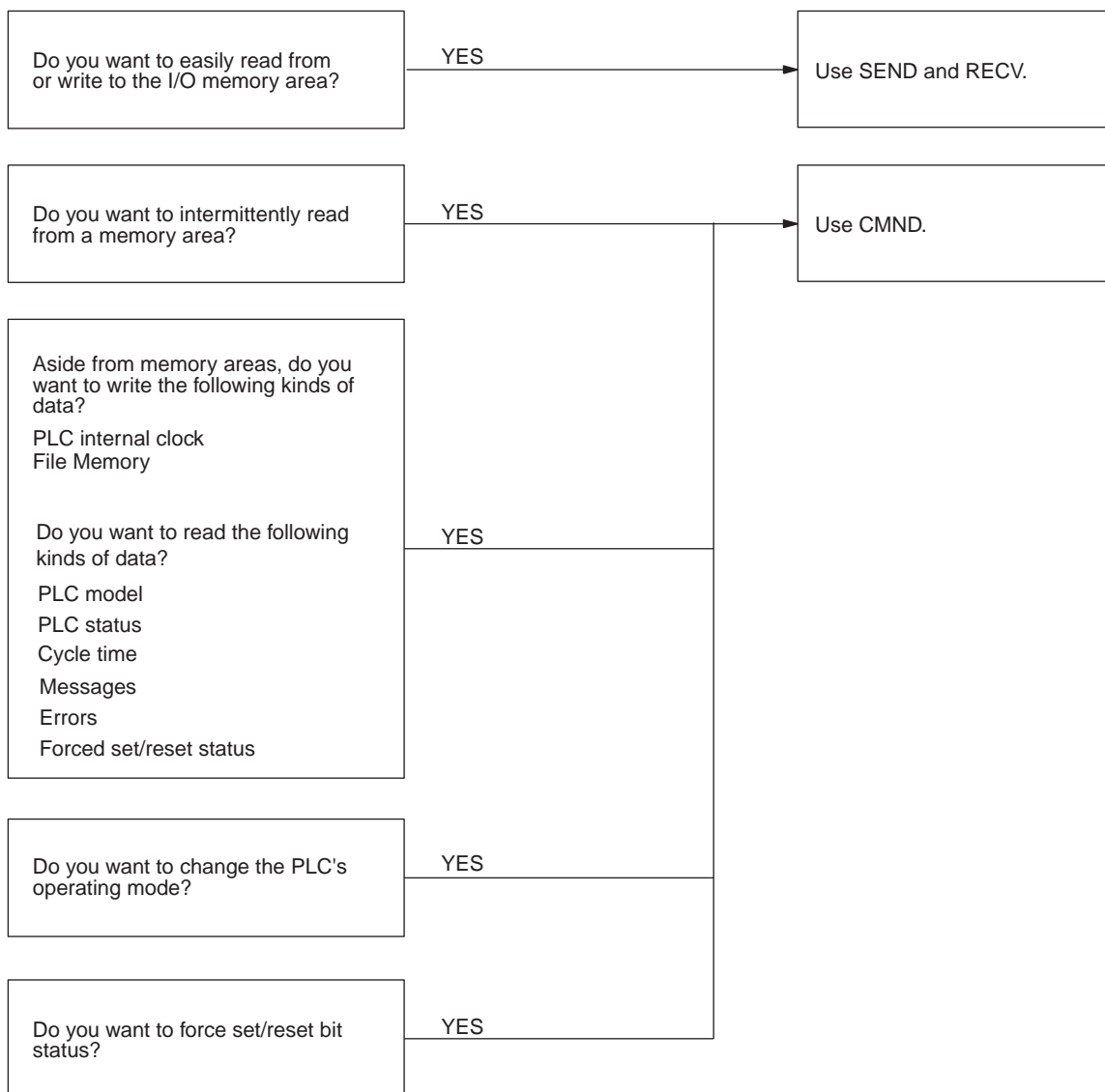

6-2-1 Message Service Operations

Instruction	Local node	Remote node		Communications contents	Data length	Broadcasting	Network connections
	CS, CVM1, or CV	CS, CVM1, or CV	Computer				
SEND and RECV	Yes	Yes	Yes (See note.)	Read to and write from all I/O memory areas.	990 words max. (1,980 bytes)	SEND only (no response)	Yes (up to three levels including local network), via CVM1 or CV-series.
CMND (See note.)	Yes	Yes	Yes (See note.)	Data read/write: Read to and write from all I/O memory areas. Read PLC model. Read status data. Read time data. Read and write File Memory data. Read PLC mode. PLC Control: Change PLC mode. Forced set/reset Clear PLC errors.	2,012 bytes max.	Yes (no response)	

Note If a computer is receiving commands, a program is required at the computer for sending back responses.

6-2-2 Message Service Specifications

Item	Specifications
Transmission format	1:1 SEND, RECV, or CMND 1:N SEND or CMND (broadcast)
Packet length	SEND: 990 words (1,980 bytes) max. RECV: 990 words (1,980 bytes) max. CMND: 1,990 bytes max.
Data content	SEND: Command and response for a request to send data are transferred. RECV: Command and response for a request to receive data are transferred. CMND: A wide range of command/response data can be sent.
Number of simultaneous commands	One for each of eight ports (ports 0 to 7).
Response monitor time	0000: Default setting (2 s) 0001 to FFFF: User settings (in increments of 0.1 s, 0.1 to 6553.5 s)
Number of retries	0 to F: 0 to 15

6-3 Using the Message Service

With SEND, RECV, and CMND, the Network Instruction Enabled Flag and Network Instruction Error Flag are generally written into the program as input conditions, as shown below. Only one instruction can be executed at a time for any given communications port. Exclusive control thus must be incorporated to execute nine or more instructions with CVM1 and CV-series PLCs (because CVM1 and CV-series PLCs have eight ports). A program example is given below.

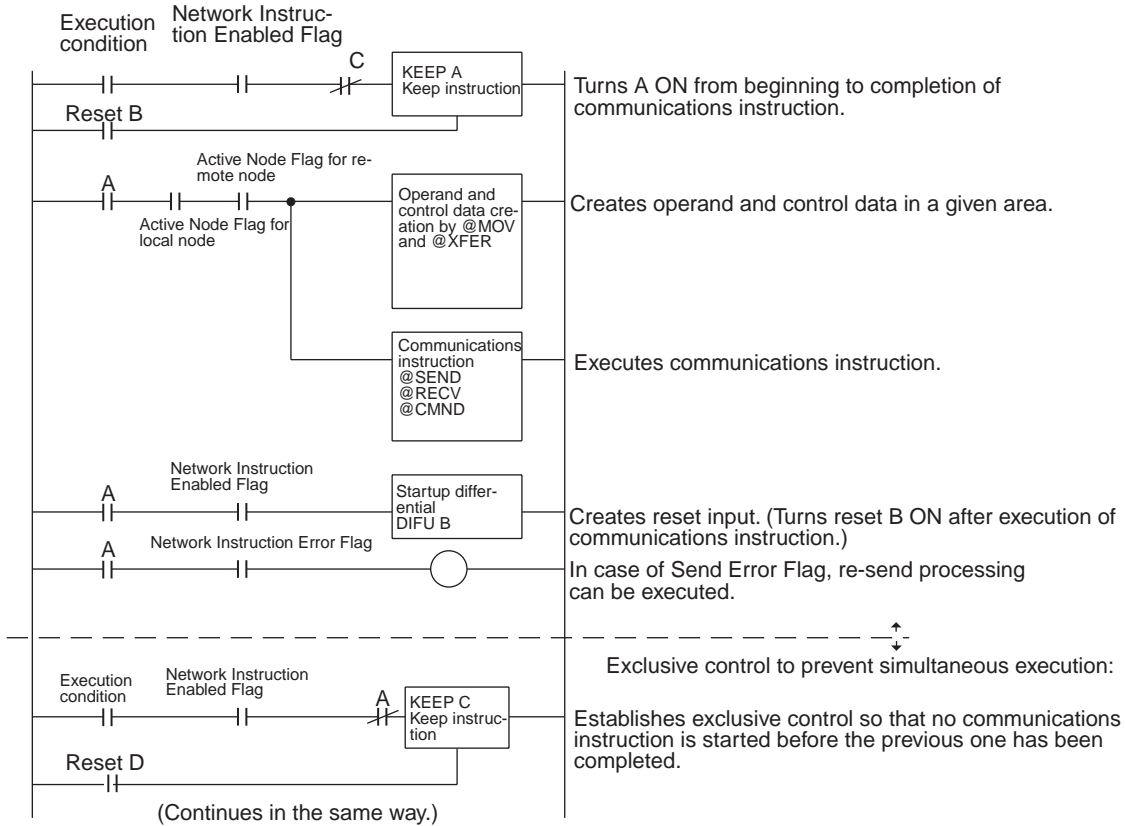

SEND/RECV Flags

CS-series PLCs

Name	Address		Contents
	Word	Bit	
Network Instruction Enabled Flag	A202	Port number corresponds to bit number, i.e., port 0: bit 00, port 1, bit 00, etc.	0: Execution not enabled (executing) 1: Execution enabled (not executing)
Network Instruction Error Flag	A219	Port number corresponds to bit number plus 8, i.e., port 0: bit 08, port 1, bit 09, etc.	0: Normal end 1: Abnormal end

Note With CS-series PLCs, ports 0 to 7 are also used for executing the PMCR (Protocol Macro) instruction, therefore these flags are used for the 4 instructions, SEND/RECV/CMND/PMCR. When the PMCR command is being executed, the same port cannot be used for SEND/RECV/CMND instructions.

CVM1 and CV-series PLCs

Name	Address		Contents
	Word	Bit	
Network Instruction Enabled Flag	A502	Port number corresponds to bit number, i.e., port 0: bit 00, port 1, bit 00, etc.	0: Execution not enabled (executing) 1: Execution enabled (not executing)
Network Instruction Error Flag	A502	Port number corresponds to bit number plus 8, i.e., port 0: bit 08, port 1, bit 09, etc.	0: Normal end 1: Abnormal end

Network Status

The nodes on the network are shown in the following illustrations.

CS-series, CVM1, and CV-series PLCs

	15	14	13	12	11	10	9	8	7	6	5	4	3	2	1	0
1500+25×N+2	16	15	14	13	12	11	10	9	8	7	6	5	4	3	2	1
1500+25×N+3	32	31	30	29	28	27	26	25	24	23	22	21	20	19	18	17
1500+25×N+4	49	47	46	45	44	43	42	41	40	39	38	37	36	35	34	33
1500+25×N+5	—	—	62	61	60	59	58	57	56	55	54	53	52	51	50	49

N: Unit number -: Not used
(The numbers in the grid are the node numbers for the corresponding bit.)

0: Not participating in network.
1: Participating in network.

*1 When Optical Bus Controller Link Units/Boards (CLK11) are combined in a network with Optical Ring Controller Link Units/Boards in token-bus mode, only node addresses 1 to 32 are checked for their participation status.

Communications Flag Operations

- The Network Instruction Enabled Flag turns OFF during transmission or reception, and ON after the data transmission or reception has been completed (regardless of whether an error occurs).
- The Network Instruction Error Flag retains its status until the next data transmission or reception.
- Even when there is an abnormal end, the Network Instruction Error Flag turns OFF when the next communications instruction is executed.

Example

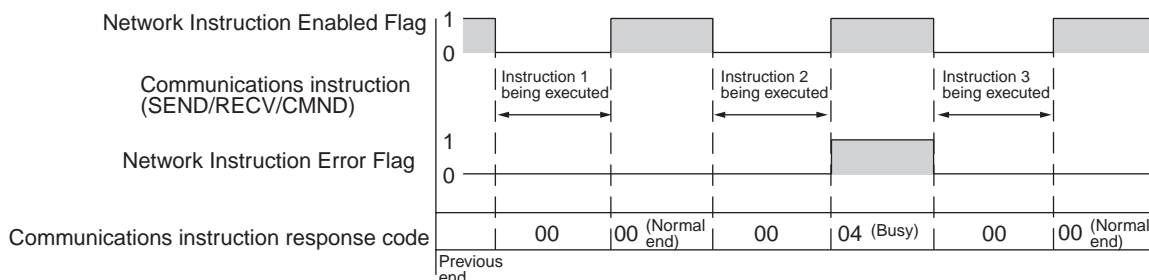

Communications Instruction Response Codes

The status after a communications instruction has been executed is reflected in the words shown in the following table. During instruction execution, it becomes "00" or "0000," and it is reflected here after the execution has been completed.

PLC	Word	Bits	Contents
CS-series	A203	---	Port 0 response code
	A204	---	Port 1 response code
	A205	---	Port 2 response code
	A206	---	Port 3 response code
	A207	---	Port 4 response code
	A208	---	Port 5 response code
	A209	---	Port 6 response code
	A210	---	Port 7 response code
CVM1 and CV-series	A503	---	Port 0 response code
	A504	---	Port 1 response code
	A505	---	Port 2 response code
	A506	---	Port 3 response code
	A507	---	Port 4 response code
	A508	---	Port 5 response code
	A509	---	Port 6 response code
	A510	---	Port 7 response code

CS-series, CVM1, and CV-series Response Codes

The results of executing SEND, RECV, and CMND instructions are reflected as one word (two bytes) of data. Instruction response codes are the same as FINS command response codes. Response code bits 08 to 15 correspond to the first byte of the response code, and response code bits 00 to 07 correspond to the second byte of the response code. For details, refer to 6-6 *Response Codes*.

Simultaneous Execution of Communications Instructions

CS-series, CVM1, and CV-series PLCs

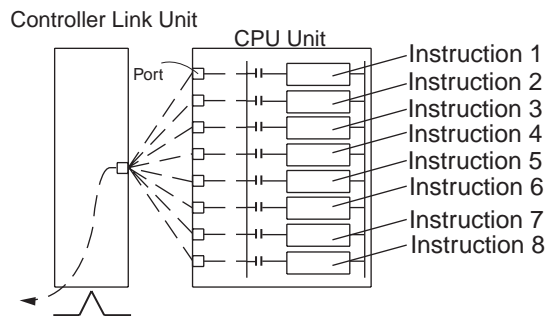

There are eight communications ports, so eight communications can be executed simultaneously. Only one message is refreshed from the CPU Unit to the Controller Link Unit and one from the Controller Link Unit to the CPU Unit for each CPU Bus Unit service time.

PLC Programming Examples

CS-series PLCs

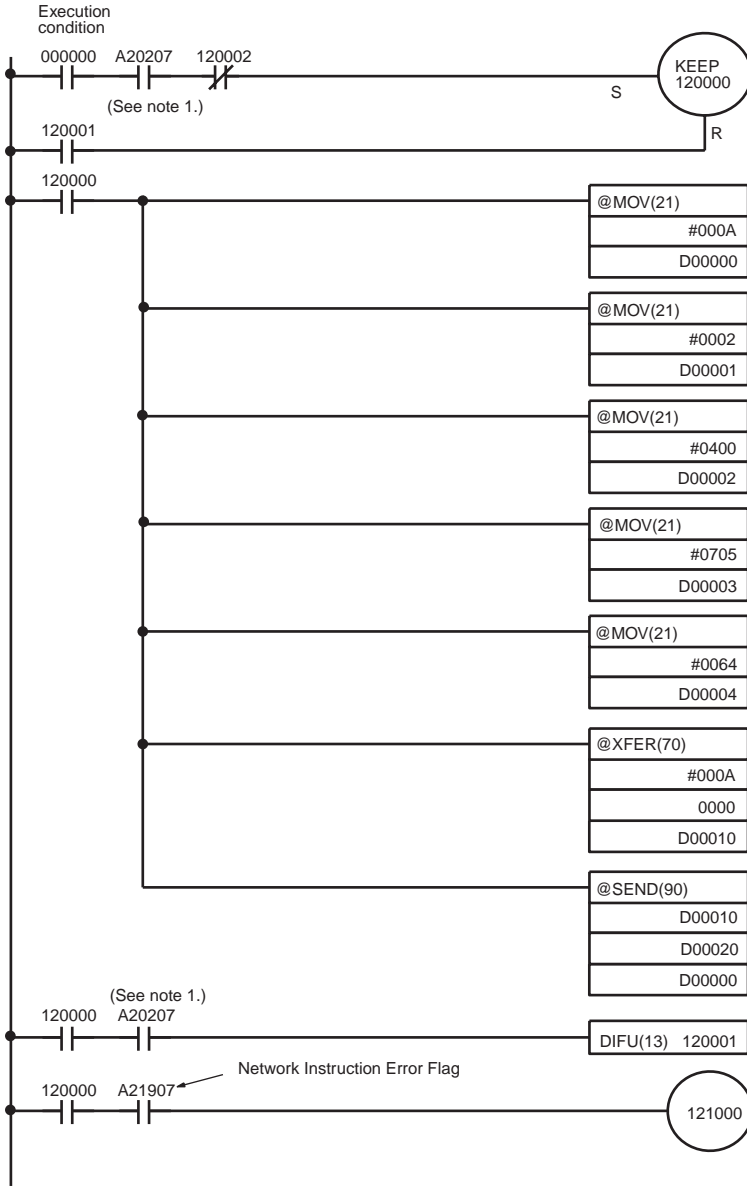

The transmission program will run when CIO 00000 turns ON, provided that the Network Instruction Enabled Flag is ON and the RECV instruction has not been executed.

CIO 120000 remains ON while the SEND instruction is being executed, and it turns OFF when instruction execution has been completed.

Control Data Preparation

Word	Content	Meaning
D00000	0 0 0 A	10 send words
D00001	0 0 0 2	Destination network address= 2
D00002	0 4 0 0	Remote node address = 4 Destination Unit address = 0
D00003	0 7 0 5	Response required Port No. 7 used No. of resends = 5
D00004	0 0 6 4	Response monitoring time = 10 s

Transfers the 10 words beginning at CIO 0000 to the 10 words beginning at D00010.

Transfers the 10 words beginning at DM 00010 of the local node to the words beginning with D00020 at network address 2, node address 4, and Unit address 0 (PLC).

Creates reset input.

Turns ON to indicate transmission error.

(Continued on the next page)

(Continued from the previous page)

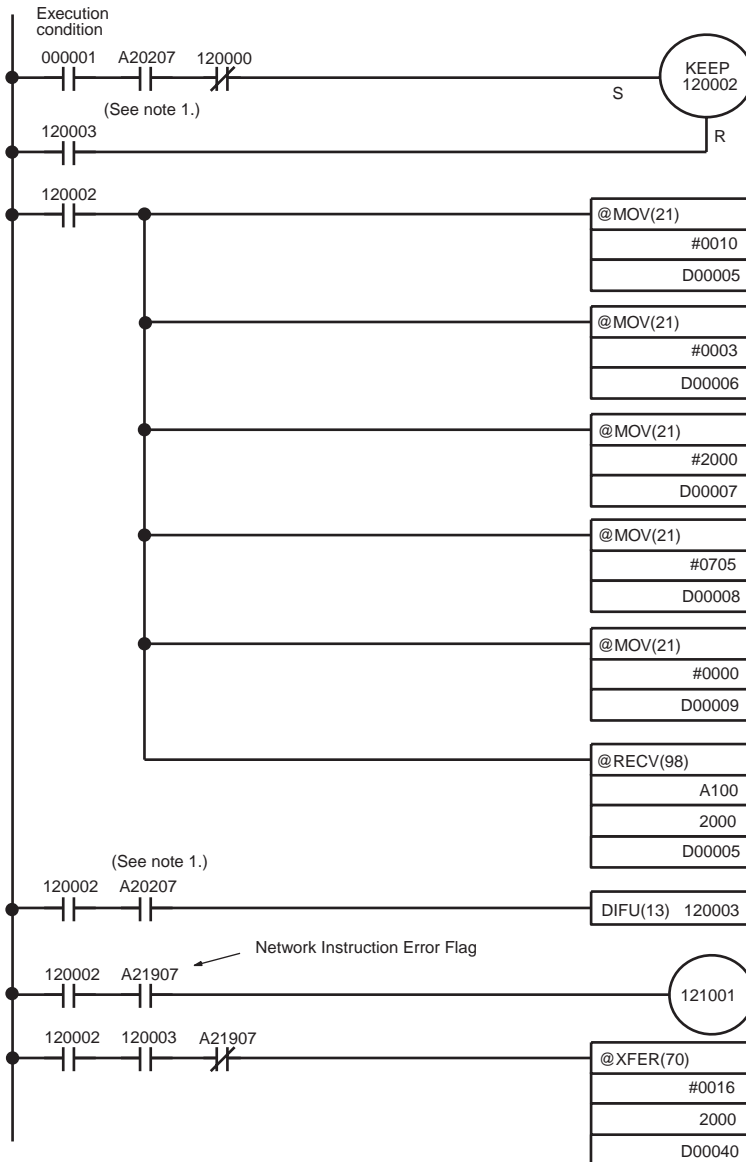

The reception program will run when CIO 00001 turns ON, provided that the Network Instruction Enabled Flag is ON and the SEND instruction has not been executed.

CIO 120002 remains ON while the RECV instruction is being executed, and it turns OFF when instruction execution has been completed.

Control Data Preparation

Word	Content	Meaning
D00005	0 0 1 0	16 receive words
D00006	0 0 0 3	Destination network address = 3
D00007	2 0 0 0	Remote node address = 32 Destination Unit address = 0
D00008	0 7 0 5	Response required Port No. 7 used No. of resends = 5
D00009	0 0 0 0	Response monitoring time = Default

Transfers the 16 words beginning at A100 of network address 3, node address 32, and Unit address 0 (PLC) to 2000.

Creates reset input.

Turns ON to indicate reception error.

Transmitted data (16 words from 2000) moved into words beginning at D00040 for storage.

- Note**
1. With CS-series PLCs, the Network Instruction Enabled Flag in A20200 to A20207 corresponding to communications ports will be OFF even when PMCR (PROTOCOL MACRO) is being executed.
 2. When using the sample program, make sure that the bits and words used in the sample program are not the same as those in the user program or by Special I/O Units.

CVM1 and CV-series PLCs

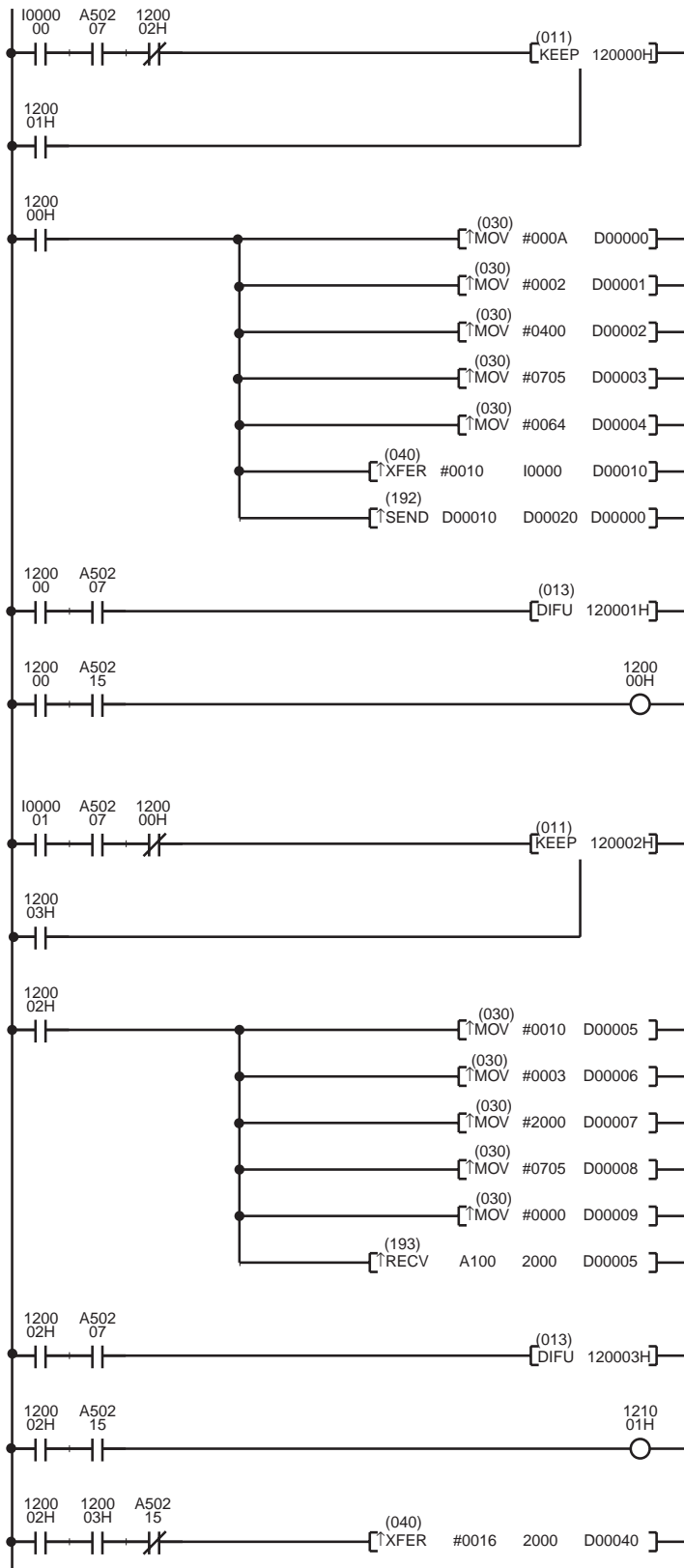

The transmission program will run when I000000 is ON, provided that the Network Instruction Enabled Flag for port 7 is ON and the RECV instruction has not been executed.

CIO 120000H remains ON while the SEND instruction is being executed, and it turns OFF when the execution of the instruction has been completed.

Word	Content	Meaning
D00000	00 0A	No. of send words: 10H
D00001	00 02	Remote network address: 2
D00002	04 00	Remote node address: 4 Remote unit address: 0
D00003	07 05	Response required Communications port no.: 7 Number of retries: 5
D00004	00 64	Response monitor time: 10 s

The 10-word data starting from I0000 is stored in D00010 and following words.

Transfers 10 words of data from the local node to the PLC (from D00020 onwards) at network address 2, node no. 4, unit address 0.

Creates reset input.

Transmission error display

The reception program will run when I000001 is ON, provided that the Network Instruction Enabled Flag for port 7 is ON and the SEND instruction has not been executed.

CIO 120002H remains ON while the RECV instruction is being executed, and it turns OFF when the execution of the instruction has been completed.

Word	Content	Meaning
D00005	00 10	Number of receive words: 16H
D00006	00 03	Remote network address: 3
D00007	20 00	Remote node address: 32 Destination Unit address: 0
D00008	07 05	Response required Communications port no.: 7 Number of retries: 5
D00009	00 00	Response monitor time: Default

Transfers 16 words of data (from A100 onwards) from the PLC at network address 3, node no. 32, unit address 0, to words 2000 onwards.

Creates reset input.

Reception error display

Reception data processing
When the data is received without an error, the 16-word data received at CIO 2000 and following words is stored in D00040 and following words on the same PLC.

Note When using the sample program, make sure that the bits and words used in the sample program are not the same as those in the user program or Special I/O Units.

6-4 FINS Commands and Responses

6-4-1 FINS Communications Service

The FINS communications service is a communications protocol developed by OMRON for FA control devices. It can be used for reading from and writing to PLC memory, or for controlling various operations, without having to create a user's program at the PLC. The FINS communications service has its own independent address system which does not rely on the actual network address system, so it can carry out communications in the same way regardless of whether the PLC at the local node is on a Controller Link Network or some other FA network (e.g., SYSMAC NET or SYSMAC LINK). For details on FINS commands addressed to CS/CJ-series CPU Units, refer to the *CS/CJ Series Communication Commands Reference Manual* (Cat. No. W342) and for details on FINS commands addressed to CVM1/CV-series CPU Units, refer to the *FINS Commands Reference Manual* (Cat. No. W227).

6-4-2 Sending and Receiving FINS Commands and Responses

FINS commands can be sent by using the CMND instruction with a CVM1, CV-series, CS-series, or CQM1H-series PLC. The following diagram shows the data format for sending FINS commands and receiving responses. The data that is sent and received is all hexadecimal unless otherwise noted.

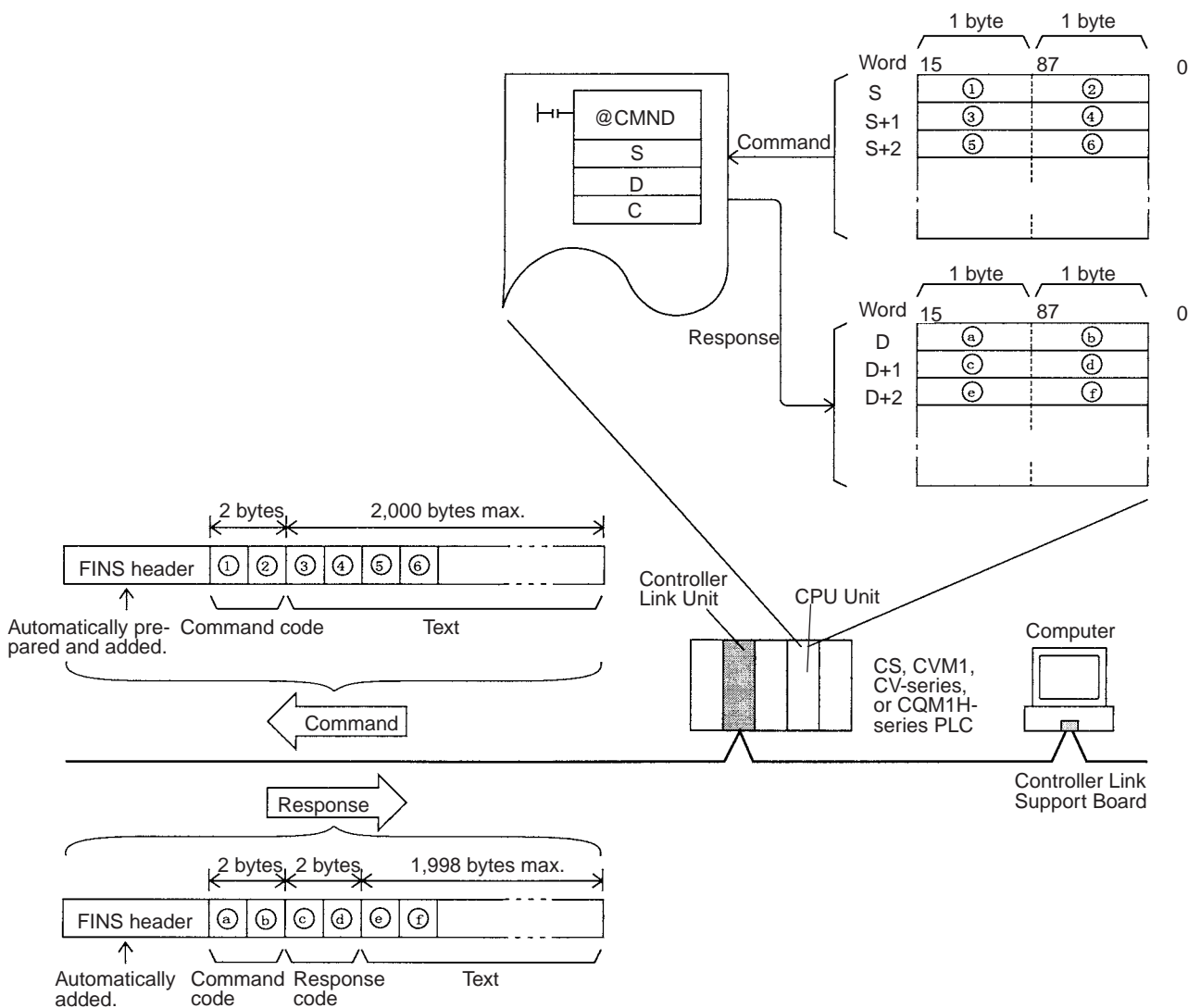

Command Codes

The command code consists of two bytes of data, and indicates the contents of the command. A FINS command must begin with a 2-byte command code, and any parameters must follow the command code.

Response Codes

The response code consists of two bytes of data, and indicates the result of the command execution. The first byte is the MRES (main response code), which indicates the broad classification of the execution result. The second byte is the SRES (sub-response code), which gives the detailed classification.

The following table shows the main response codes and the execution results. For a more detailed listing of response codes, including the sub-response codes, refer to 6-6 *Response Codes*.

MRES	Execution result	MRES	Execution result
00	Normal completion	21	Write not possible
01	Local node error	22	Not executable in current mode
02	Remote node error	23	No unit
03	Communications controller error	24	Start/stop not possible
04	Not executable (service not supported)	25	Unit error
05	Routing error	26	Command error
10	Command format error	30	Access error

MRES	Execution result	MRES	Execution result
11	Parameter error	40	Service interrupted by abort
20	Read not possible		

6-4-3 Applicable Units for FINS Commands

The parameters used with FINS commands and responses depend on the Unit to which the command is being sent. The FINS commands and responses addressed to Controller Link Units are explained in this manual. For details on other FINS commands and responses, refer to the manuals for the relevant Units. In addition, for commands addressed to CS/CJ-series CPU Units, refer to the *CS/CJ Series Communications Commands Reference Manual* (Cat. No. W342), and for commands addressed to CVM1/CV-series CPU Units, refer to the *FINS Commands Reference Manual* (Cat. No. W227).

When FINS commands are sent via a Host Link System for CVM1, CV-series, or CS-series PLCs, be sure to use the command format for relaying between networks.

6-5 Commands and Responses for Controller Link Units

6-5-1 Command Codes

Command code	Data link operation mode		Name	Page	
	Active	Inactive			
04	01	Not valid	Valid	DATA LINK START	163
	02	Valid	Not valid	DATA LINK STOP	163
05	01	Valid	Valid	CONTROLLER DATA READ	163
06	01	Valid	Valid	CONTROLLER STATUS READ	164
	02	Valid	Valid	NETWORK STATUS READ	166
	03	Valid	Valid	DATA LINK STATUS READ	168
	04	Valid	Valid	CONNECTION DATA READ	169
	05	Valid	Valid	NETWORK DISCONNECT DATA READ	171
	06	Valid	Valid	NETWORK DISCONNECT DATA CLEAR	173
08	01	Valid	Valid	ECHOBACK TEST	174
	02	Valid	Valid	BROADCAST TEST RESULTS READ	174
	03	Valid	Valid	BROADCAST TEST DATA SEND	175
21	02	Valid	Valid	ERROR LOG READ	175
	03	Valid	Valid	ERROR LOG CLEAR	176

Note Command codes 0604, 0605, and 0606 are valid only for Optical Ring Controller Link Units in token-ring mode. They cannot be used in token-bus mode or with any other Controller Link Units.

6-5-2 DATA LINK START

Starts the Controller Link Network data links.

Command Block

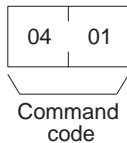

Response Block

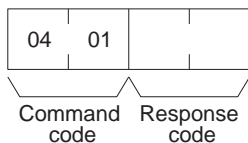

The DATA LINK START command can be received for either automatically or manually set data links. An error will occur if manually set data links are specified and yet data link tables do not exist.

The node that receives this command and starts the data links will become the data link startup node. For automatically set data links, the data links will be executed according to the settings at the startup node.

6-5-3 DATA LINK STOP

Stops the Controller Link Network data links.

Command Block

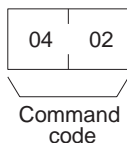

Response Block

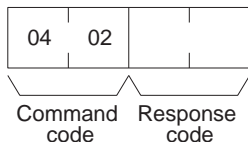

The DATA LINK STOP command can be received only while the data links are active. An error will occur if this command is sent at any other time.

This command can be received by any node that is participating in the data link.

6-5-4 CONTROLLER DATA READ

Reads the following information about the Controller Link Unit:

- Model number
- Version
- Connection method
- Node address
- Unit address
- Network address

Command Block

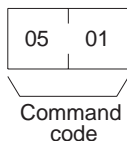

Response Block

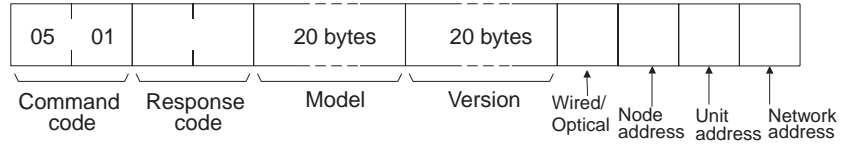

Parameters

Model number, version (response): The Controller Link Unit’s model number and version are returned as shown below, each 20 characters in ASCII code. If fewer than 20 bytes of data are used, 20 (Hex) (i.e., spaces) will be returned for the remaining bytes. In the version numbers shown below, the spaces are represented by boxes (□).

Optical Ring Controller Link Unit for CS-series PLCs:

CS1W-CLK12-V1□□□□□□□□

Version V*□V*□V*□□□□

The leftmost “V*” (*: version) represents the Communications Controller data link level version number. The middle one represents the Communications Controller network level version number. The rightmost one represents the Controller Link Unit version number.

Connection Method (Response)

The connection method parameter for the Controller Link Unit (wired or optical bus/ring) is configured as follows:

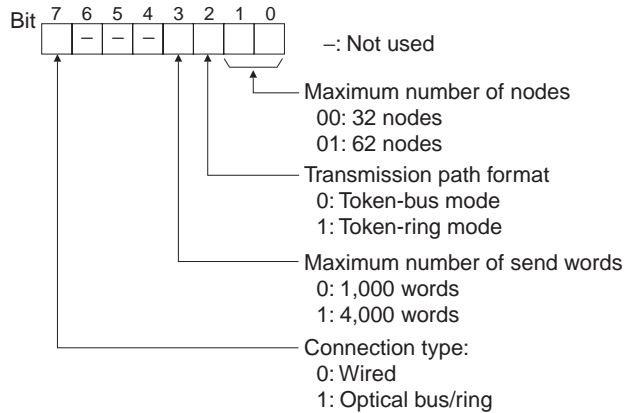

Node address (response): The Controller Link Unit’s node address is returned between 01 and 3E Hex (1 to 62).

Unit Address (response): The Unit address set for the Controller Link Unit (10 Hex + Unit number), is returned in hexadecimal. Even when there is a Unit number setting error, the Unit address is returned.

Network Address: The Controller Link Unit’s network address, as set in the routing table, is returned in hexadecimal. When the routing table has not been set, the address becomes 00 Hex.

6-5-5 CONTROLLER STATUS READ

Reads the Controller Link Unit’s controller status.

Command Block

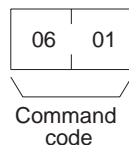

Response Block

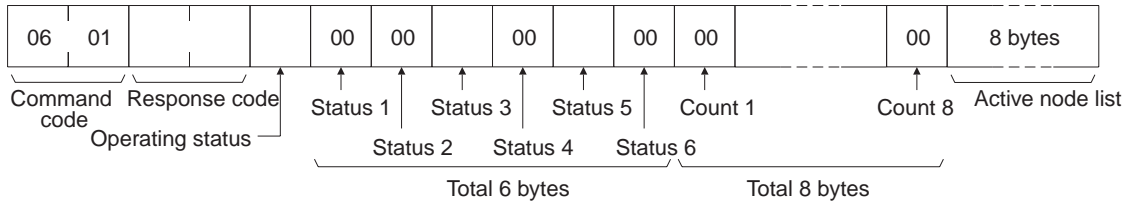

Parameters

Operating status (response): The operating status of the data links as follows:

00 (Hex): Data links inactive.

01 (Hex): Data links active.

02 (Hex): Local data links not active. (The data links are active in the network, but the local node is not participating.)

Status 1, Status 4, Status 6 (response): Not used by the Controller Link Unit. Always set to 00 (Hex).

Status 2 (response): The Controller Link Network’s transmission speed and the status of the Controller Link Unit’s backup power supply is returned with the following configuration.

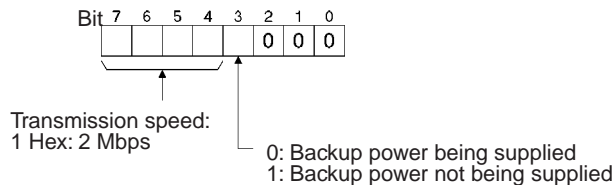

Status 3 (response): Error information. The configuration is as follows:

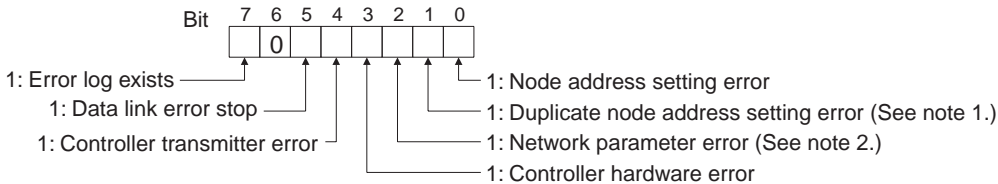

- Note**
1. This bit may be 1 if an Optical Ring Controller Link Unit is mistakenly connected to an Optical Bus Network or SYSMAC LINK Network.
 2. A network parameter error occurs if the registered network parameter contents do not match the actual network parameter contents after the power is turned on. The system, however, will not stop. When a network parameter error occurs, the actual network parameter contents are automatically registered to that Unit.

Status 5 (response): Error information related to the Unit and the PLC. The configuration is as follows:

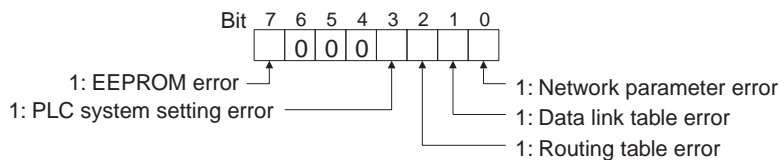

A network parameter error, data link table error, or routing table error occurs if an error is discovered when the parameters and tables are checked at power up.

A PLC system setting errors occurs if the Controller Link Unit is not properly recognized by a CVM1 or CV-series PLC.

A PLC model error occurs if a C200HX/HG/HE Controller Link Unit is mounted to another type of PLC.

Count 1 to Count 8 (response): The total number of times for each of the items listed below is returned as 1 byte of hexadecimal data.

- Count 1: Number of CRC errors
- Count 2: Number of token re-sends
- Count 3: Number of token returns
- Count 4: Number of token timeouts
- Count 5: Number of polling timeouts
- Count 6: Number of controller changes
- Count 7: Number of active node changes
- Count 8: Reserved for system use.

Network participation status (response): The following diagram shows the bits corresponding to node addresses in the Controller Link Network. When a bit is returned as "1," it means that the corresponding node is participating in the network.

Bit	7	6	5	4	3	2	1	0
Byte 1	8	7	6	5	4	3	2	1
Byte 2	16	15	14	13	12	11	10	9
Byte 3	24	23	22	21	20	19	18	17
Byte 4	32	31	30	29	28	27	26	25
Byte 5	40	39	38	37	36	35	34	33
Byte 6	48	47	46	45	44	43	42	41
Byte 7	56	55	54	53	52	51	50	49
Byte 8	-	-	62	61	60	59	58	57

Reserved for system use.

The numbers in the boxes indicate the node addresses. The bit status of a particular node address shows whether or not that node participates in the network.

- 0: Not part of network
- 1: Part of network

(All boxes marked by "-" are reserved for system use and fixed at "0.")

6-5-6 NETWORK STATUS READ

Reads the operating status of the entire Controller Link Network.

Command Block

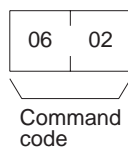

Response Block

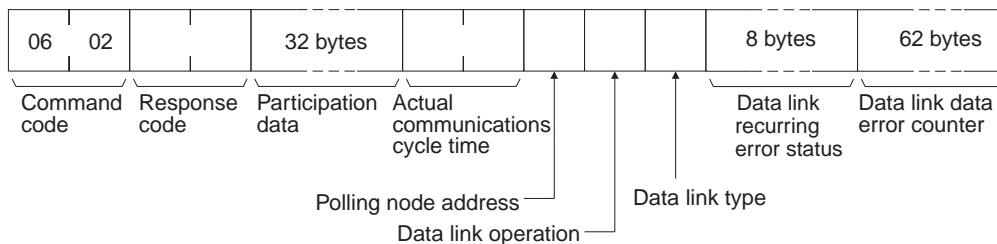

Parameters

Participation data (response): This parameter indicates the active status of individual nodes with respect to the network (i.e. their participation in the network). As shown in the following diagram, that status is expressed in four bits corresponding to the node address.

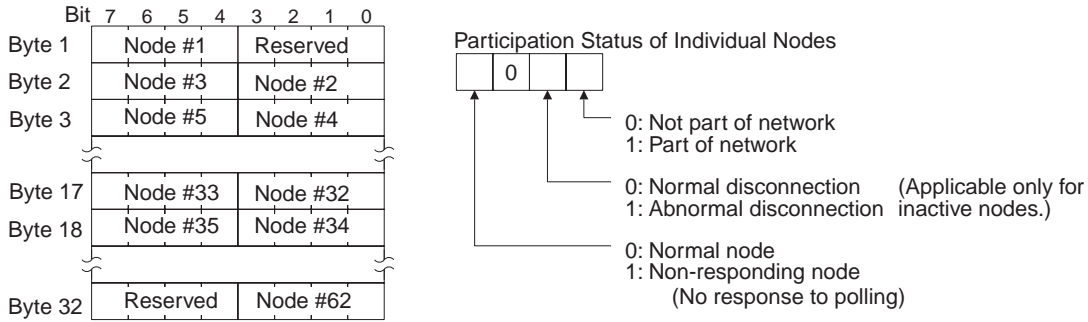

Actual communications cycle time (response): The actual communications cycle time is returned in units of 100 μs in hexadecimal.

Polling node address: The current polling node address is returned in hexadecimal.

Data link operation (response): Indicates the status of data link operation in the network.

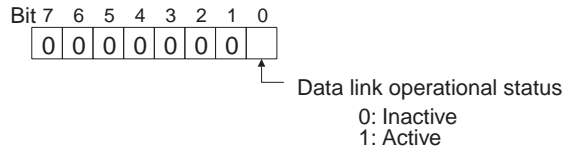

Data link type (response): Indicates the data transmission status of the local node's data links. It is configured as shown in the following diagram. This parameter is valid only during data link operation. While data link operation is inactive, the value from the previous operation is retained.

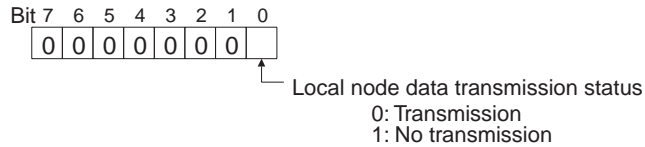

Data link recurring error status (response): Indicates whether an error continues to occur at a node when data link data is received. If an error continues to occur at the same node when the data is received, the bit corresponding to that node turns to "1" (i.e., turns ON). The configuration is shown in the following diagram.

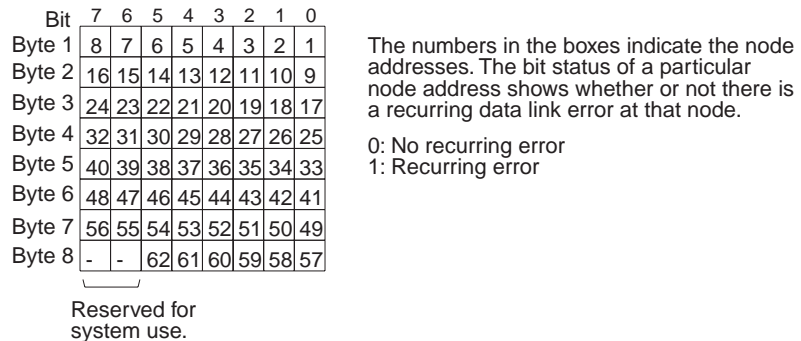

Data link data error counter (response): The total number of data link data reception errors occurring at all nodes (node addresses 1 to 62) is returned as a total count from the time the power was turned on. It is expressed, in hexadecimal, as one byte per node. The count can range from 0 to 255 (i.e., 0 to FF in hexadecimal).

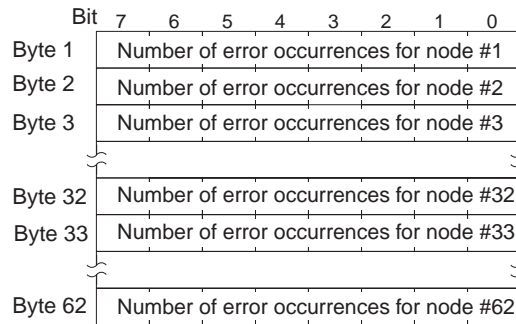

6-5-7 DATA LINK STATUS READ

Reads the data link operational status.

Command Block

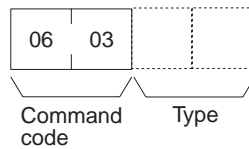

Response Block

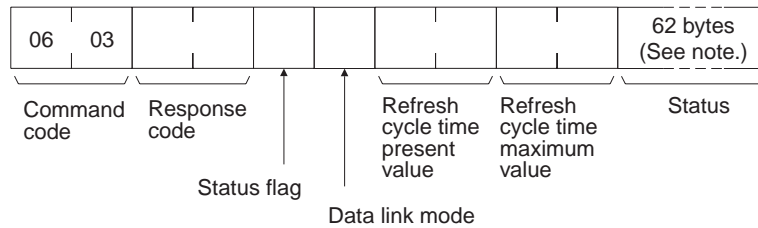

Note If 0000 Hex is specified as the command type (or if it is omitted), 32 bytes will be used for the status.

Parameters

Status flag (response): The overall data link status is returned in one byte of data, as shown in the following diagram.

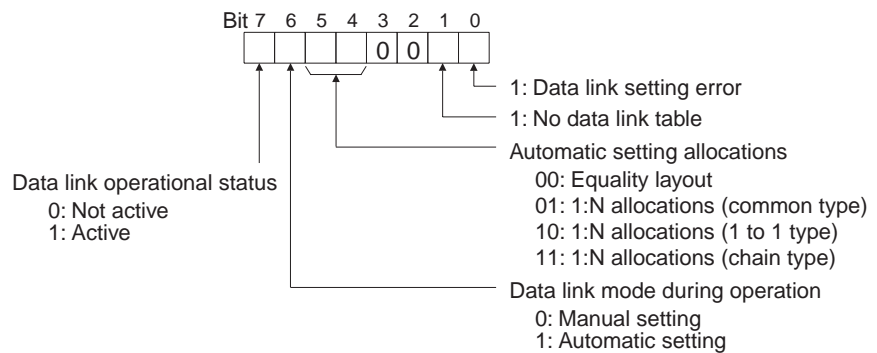

Data link mode (response): The data link mode during operation is returned in one byte of data, as follows:

- 01 (Hex): Automatic
- 03 (Hex): Manual

Refresh cycle time present value, refresh cycle time maximum value (response): The present value and the maximum value of the cycle time for refreshing the data link area are both returned in units of 1 ms, in hexadecimal, within a range of 0000 to 00FF (decimal: 0 to 255).

Status (response): The data link status of each mode is returned as shown in the following diagram. It is the same as the data link status in the PLC. (Refer to page 130.)

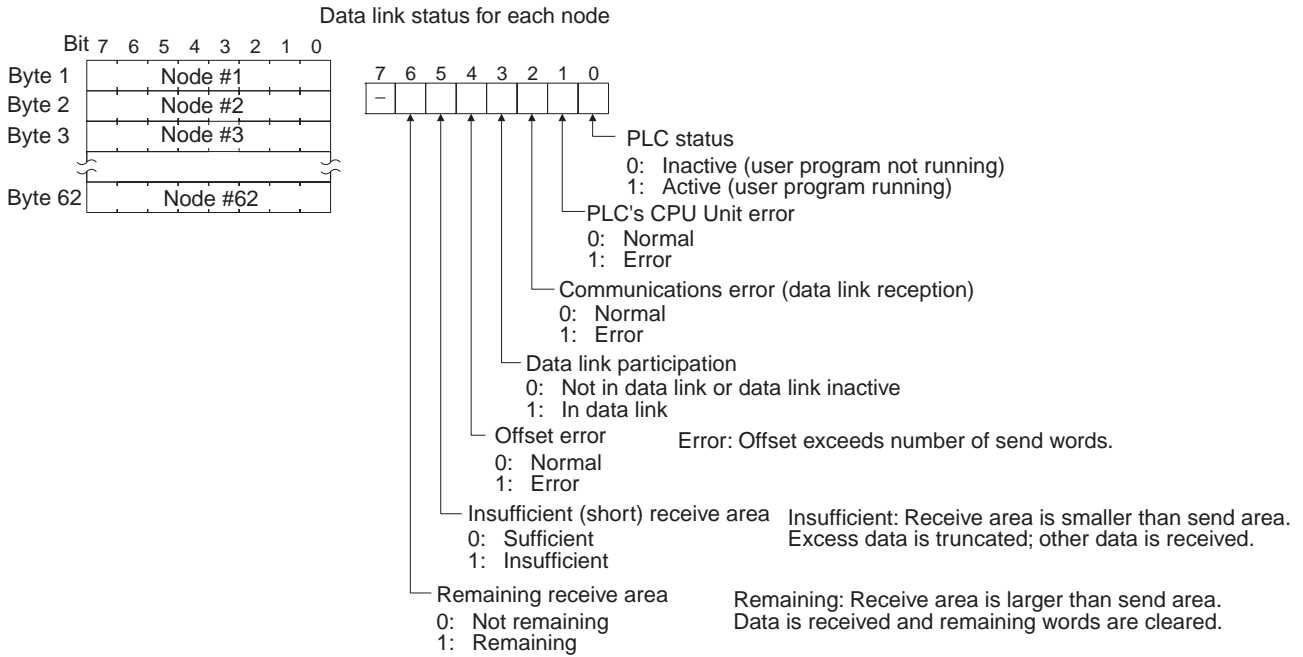

If 0000 Hex is specified as the command type (or it is omitted), only the 32 bytes for nodes 1 to 32 will be returned.

1. The data link status is not refreshed while the data links are inactive.
2. Nodes which are not active in the network or participating in the data links will generate communications errors.
3. Any node which is not active in the network retains the status that existed immediately prior to the generation of the communications error.
4. Only the PLC operation status and PLC error status will be refreshed for nodes that are not participating in a data link that is active in the network.

6-5-8 CONNECTION DATA READ

Reads in order of connection (descending direction) the node addresses of Controller Link Units connected in a ring. This command can only be used in token-ring mode, for Optical Ring Controller Link Units (H-PCF cable or GI cable).

Command Block

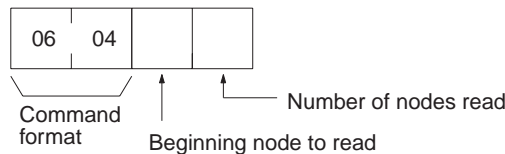

Response Block

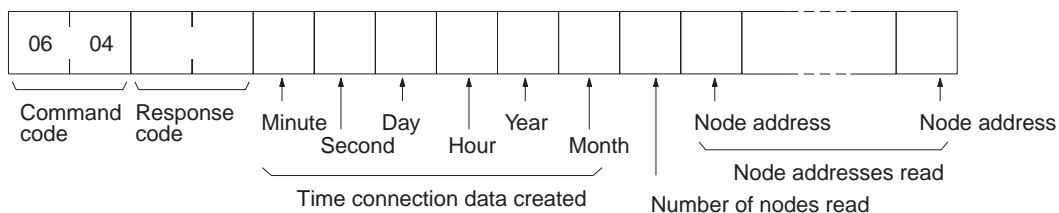

Parameters

Beginning node to read (command): With the local node as the starting point (0), specify the node for beginning reading, with a 1-byte hexadecimal value (2 digits) counted as 1, 2, etc., in the descending (SL2) direction. Set the value from 00 to 3E Hex (decimal: 0 to 62).

Number of nodes read (command, response): For the command, specify the number of node addresses to read. All node addresses are read in order from the local node in the descending (SL2) direction. In the response, the number of nodes actually read is returned, in the range of 01 to 3E Hex (decimal: 0 to 62).

With the command, the local node is read first regardless of the “beginning node to read” parameter setting. The number of other nodes addresses to read, therefore, is the “number of nodes read” minus 1.

Time connection data created (response): The time that the connection configuration data was last changed is returned in one byte (2 digits) BCD for each of the following in order: minute, second, day, hour, year, month. The data is changed with each communications cycle when in token-ring mode with a normal ring connection.

The year setting is for the two rightmost digits of the year. The hour setting is made from 00 to 23.

The time will be returned according to the time data set at the local node.

Node address (response): The node address for each node is returned in one byte (2 digits) hexadecimal.

With this response, the node address of the local node is returned first, regardless of the “beginning node to read” parameter setting. Then the rest of the node addresses are returned in order from the node set in the “beginning node to read” parameter.

Explanation

When the range specified in the “beginning node to read” and “number of nodes read” parameters is connected as a ring in relation to the local node, the node addresses are read until the node which is one node in the ascending direction from the local node. This will result in a normal completion.

In the following network, for example, the beginning node to read is 25, and the number of nodes read is 6.

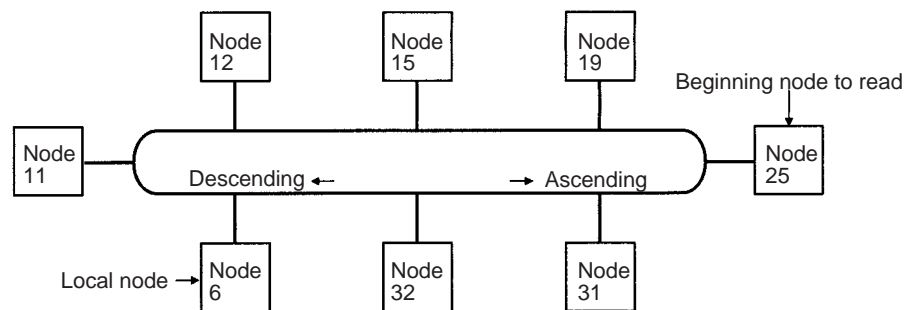

The following node addresses will be returned as the response.

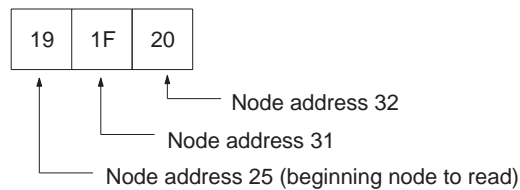

- Note**
1. In the event of a disconnection, the last data that was changed and saved will be returned.
 2. If a node is down even though nothing is disconnected, it will be skipped over for reading.

6-5-9 NETWORK DISCONNECT DATA READ

Reads the disconnection status of the Controller Link Unit. This command can only be used in token-ring mode, for Optical Ring Controller Link Units (H-PCF cable or GI cable).

Command Block

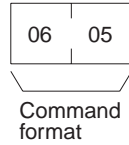

Response Block

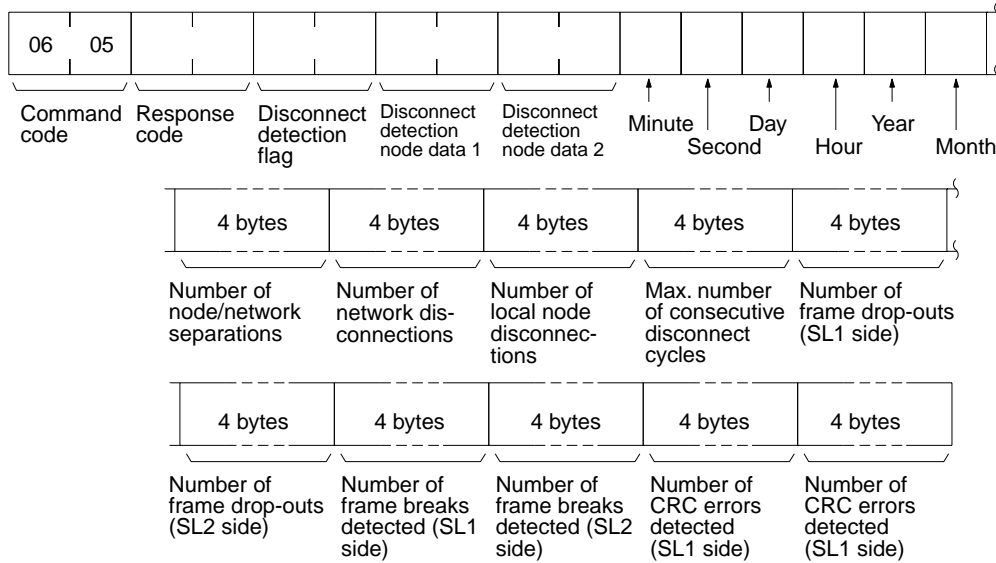

Parameters

Disconnect detection flag (response): Disconnection detections can be returned as follows:

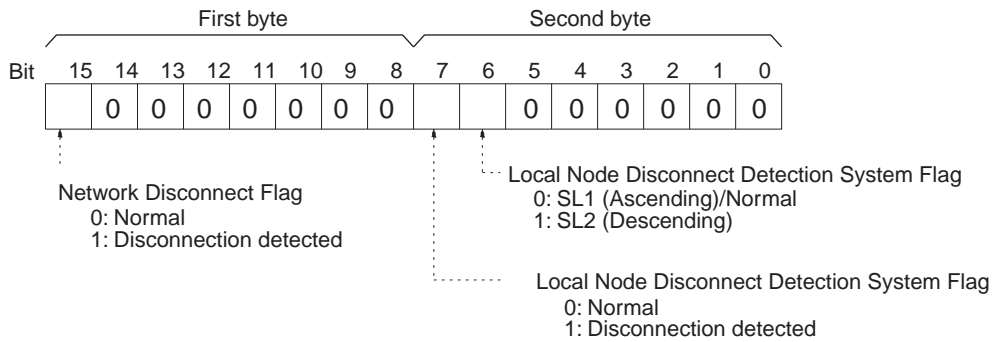

Disconnect detection node data 1, 2 (response): The node address of a node for which a detection is detected, along with the direction of detection at that mode, are returned as follows:

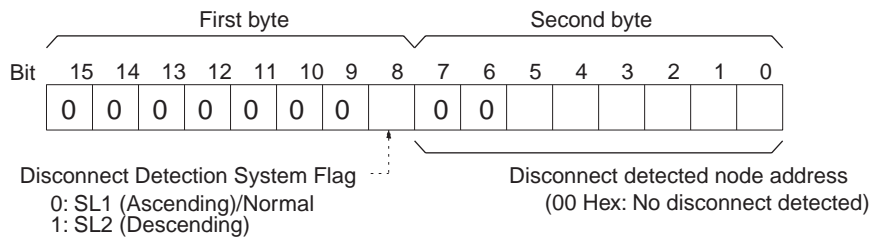

The data for the two modes is returned by “disconnect detect node data 1” and “disconnect detect node data 2.”

Time of beginning disconnection data recording: The time that the recording of the disconnection data was begun is returned in one byte (2 digits) BCD for each of the following in order: minute, second, day, hour, year, month.

The time at which the last of the following was executed becomes the time for this parameter: Local node powered up, Controller Link Unit restarted, or disconnection data cleared.

The year setting is for the two rightmost digits of the year. The hour setting is made from 00 to 23.

The time will be returned according to the time data set at the local node.

Number of node/network separations (response): The number of times that the local node is separated from the network from the “time of beginning disconnection data recording” onwards is returned in 4 bytes (8 digits) hexadecimal.

Number of network disconnections (response): The number of times that disconnection data is received from the polling node from the “time of beginning disconnection data recording” onwards is returned in 4 bytes (8 digits) hexadecimal. If the same disconnection data is continuously detected with each communications cycle, however, it will be regarded as the same disconnection and will not increase the count.

Number of local node disconnections (response): The number of times that disconnection data is detected by the local node from the “time of beginning disconnection data recording” onwards is returned in 4 bytes (8 digits) hexadecimal. If the same disconnection data is continuously detected with each communications cycle, however, it will be regarded as the same disconnection and will not increase the count.

Maximum number of consecutive disconnect cycles (response): The maximum number of consecutive cycles in which disconnection data from the polling node is detected is returned in 4 bytes (8 digits) hexadecimal. (The number is counted starting from the “time of beginning disconnection data recording.”)

A rough approximation of the time during which data may have been lost can be obtained by multiplying this value by the maximum communications cycle time for the Controller Link Network.

Number of frame drop-outs (SL1, SL2) (response): This response indicates the number of times that the data (frame) was correctly received by another system but could not be received by the local system. (The total from the “time of beginning disconnection data recording” onwards is returned in 4 bytes (8 digits) hexadecimal.)

Number of frame breaks detected (SL1, SL2) (response): This response indicates the number of times that the data (frame) was correctly received by another system but could not be detected at the local system except by carrier. (The total from the “time of beginning disconnection data recording” onwards is returned in 4 bytes (8 digits) hexadecimal.)

Number of CRC errors detected (SL1, SL2) (response): This response indicates the number of CRC errors and Manchester errors. (The number is counted from the “time of beginning disconnection data recording” onwards.)

Explanation

When a Optical Ring Controller Link Unit is used in the token-ring mode, the disconnect detection and notification function can be used. With this function, when the Controller Link Unit detects a disconnection, it provides disconnection data to the polling node. All of the nodes in the network are then notified from the polling node. For details on the disconnect detection and notification function, refer to *10-5 Locating and Correcting Cable Disconnections*.

Aside from the disconnect detection flag parameter, disconnection information is not cleared even when communications are restored. (The present disconnection status is always reflected in the disconnect detection flag parameter.) The disconnect detection node data 1 and 2 parameters, however, are overwritten by new disconnection data.

To clear disconnection data, either execute NETWORK DISCONNECT DATA CLEAR (FINS command) or use the Controller Link Support Software (Ver. 2.00 or later). When clearing the disconnection data by executing a FINS command, it must be done separately for each node.

When Controller Link Units are used in duplex operation, if there is an active/standby switchover resulting from an error in a Unit, then the time at which this occurs will become the “time of beginning disconnection data recording” and a new disconnection record will start. (Disconnection data is not inherited from one Controller Link Unit to another.)

6-5-10 NETWORK DISCONNECT DATA CLEAR

Clears the Controller Link disconnection data. This command can only be used in token-ring mode, for Optical Ring Controller Link Units (H-PCF cable or GI cable).

Command Block

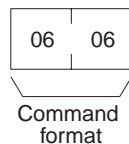

Response Block

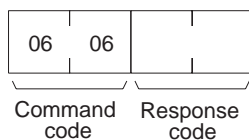

Explanation

Aside from the disconnect detection flag parameter, disconnection information is not cleared even when communications are restored. (The present disconnection status is always reflected in the disconnect detection flag parameter.) The disconnect detection node data 1 and 2 parameters, however, are overwritten by new disconnection data.

Execute this command to clear the disconnection data and restore the default status. Both the disconnection data in the Controller Link Unit and the ring status in the CPU Bus Area of the CPU Unit will be cleared.

The time at which the disconnection data is cleared will be recorded in the Controller Link Unit as the “time of beginning disconnection data recording.”

The disconnection data will only be cleared at those nodes which receive this command. For examples of programs for clearing the disconnection data from the entire network, refer to *10-5-4 Clearing the Ring Status Words*.

The disconnection data can also be cleared using Controller Link Support Software (Ver. 2.00 or later). With this method, the disconnection data is cleared all at once for all of the nodes in the network.

6-5-11 ECHOBACK TEST

Executes an echoback communications test between specified nodes.

Command Block

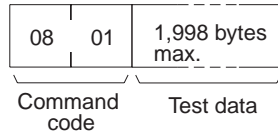

Response Block

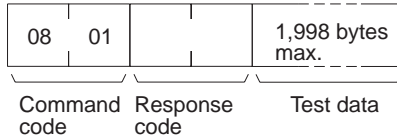

Parameters

Test data (command, response): For the command, up to 1,998 bytes of data can be specified to be sent to a specified node. For the response, the test data that was sent by the command is returned unchanged.

An error is generated if the data returned by the response is different from the data that was sent by the command.

6-5-12 BROADCAST TEST RESULTS READ

Reads for each node the results (number of receptions) of a BROADCAST TEST DATA SEND command that has been sent to all nodes in a specified network. (For details on the BROADCAST TEST RESULTS SEND command, refer to 6-5-13 BROADCAST TEST DATA SEND.)

Command Block

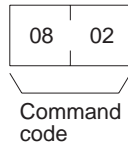

Response Block

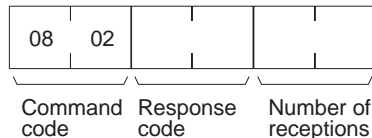

Parameters

Number of receptions (response): The number of times that broadcast test data has been received at the command remote node from the time that the last BROADCAST TEST RESULTS READ command was sent until this one was sent is returned.

An error will be generated if that number of receptions differs from the number of times that the BROADCAST TEST DATA SEND command was issued during that same period.

The *number of receptions* value being retained at the remote node is cleared when the BROADCAST TEST RESULTS READ command is executed.

6-5-13 BROADCAST TEST DATA SEND

Broadcasts test data to all nodes in a specified network.

Command Block

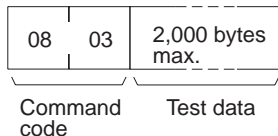

There is no response to this command.

The control data must be set as follows when this command is issued:

Remote node address: FF (Hex) (for broadcasting the data)

Remote unit address: FE (Hex) (for the Controller Link Unit)

Response required/not required: 1 (response not required)

The transmission and reception status is checked by comparing the number of times this command is issued with the *number of receptions* parameter of the BROADCAST TEST RESULTS READ command. (For details, refer to 6-5-12 BROADCAST TEST RESULTS READ.

6-5-14 ERROR LOG READ

Reads the PLC's error log.

Command Block

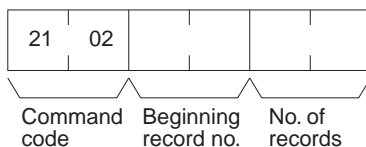

Response Block

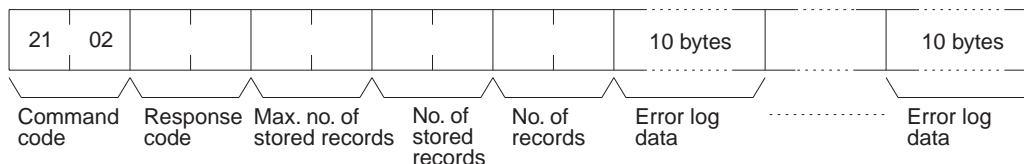

Parameters

Beginning record no. (command): Specifies the first record to be read, in two bytes (four digits) in hexadecimal. (The first record number is 0000 in hexadecimal. Designate the record number within the range given in the following table).

No. of records (command and response): Specifies the first record to be read, in two bytes (four digits) in hexadecimal. (The first record number is 0000 in hexadecimal. Designate the record number within the range given in the following table).

Max. no. of stored records (response): Specifies the maximum number of records that can be recorded.

No. of stored records (response): The number of records that have been recorded by the time the command is executed.

Parameter	Model number	CS1W-CLK13 CS1W-CLK53	CS1W-CLK12(-V1) CS1W-CLK52(-V1)
Command	Beginning record No.	0000 to 003F hex (Decimal: 0 to 63)	0000 to 0026 hex (Decimal: 0 to 38)
	No. of records	0001 to 0040 hex (Decimal: 1 to 64)	0001 to 0027 hex (Decimal: 1 to 39)

Parameter	Model number	CS1W-CLK13 CS1W-CLK53	CS1W-CLK12(-V1) CS1W-CLK52(-V1)
Response	Max. no. of stored records	0040 hex, fixed (Decimal: 64) 64 records max.	0027 hex, fixed (Decimal: 39) 39 records max.
	No. of stored records	0001 to 0040 hex (Decimal: 1 to 64)	0001 to 0027 hex (Decimal: 1 to 39)
	No. of records	0001 to 0040 hex (Decimal: 1 to 64)	0001 to 0027 hex (Decimal: 1 to 39)

Error log data (response): The specified error log records are returned in sequence starting from the beginning record number. The total number of bytes required is calculated as follows:

$$\text{No. of records} \times 10 \text{ bytes}$$

The configuration of each error record is as follows:

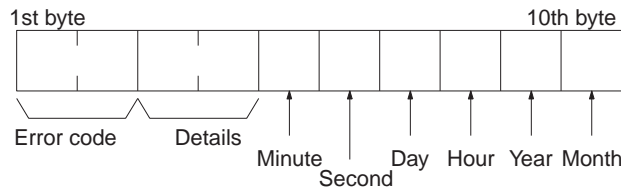

Error code, details: These parameters show the contents of errors. For details, refer to 10-3-2 Error Codes.

Date and time: These parameters show the seconds, minutes, hour (0 to 23), date, month, and year (the rightmost two digits) in BCD specifying the time that the error occurred.

- Note**
1. If the PLC does not have the specified number of records, all the records that have been stored in the PLC up to the point that the command is executed will be returned.
 2. If there is no error log registered, a response code of 1103 (Hex) will be returned.
 3. When Controller Link Units are used in duplex operation, if there is an active/standby switchover resulting from an error in a Unit, the error log is not inherited from one Controller Link Unit to another. To save the error log, use this command or the Programming Device to read the error log as appropriate.

6-5-15 ERROR LOG CLEAR

Clears all error log records and sets the error log pointer to 0.

Command Block

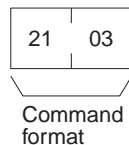

Response Block

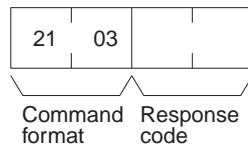

6-6 Response Codes

This section describes the response codes returned with responses to FINS commands. Response codes can be used to confirm normal completion of command execution or to troubleshoot problems when commands fail. For further troubleshooting information, refer to *SECTION 9 Troubleshooting and Maintenance* of this manual and to the operation manuals for specific Units or Systems.

6-6-1 Configuration

Response codes for FINS commands consist of two bytes that indicate the result of executing a command. The structure of the response codes is shown in the following diagram.

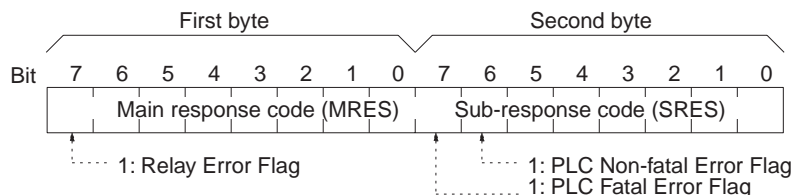

The main response code (MRES) in the first byte classifies the response and the sub-response code (SRES) in the second byte indicates details under the MRES classification.

If bit 7 of the first byte is ON, a network relay error has occurred. Refer to 6-6-2 *Network Relay Errors* for details on troubleshooting the error.

If bit 6 or 7 of the second byte is ON, an error has occurred in the PLC or computer returning the response. Refer to the operation manual for the device returning the response for details when troubleshooting the error.

6-6-2 Network Relay Errors

A network relay error will occur whenever a command cannot reach the destination. These errors can occur for several reasons: 1) Data was not successfully passed between two Link Units, 2) Data was not passed successfully between a Link Unit and another Unit, such as the PLC's CPU Unit, or 3) The destination of a gateway does not exist. In any case, the Unit that was not able to transfer data will return a response indicating a network relay error.

Bit 7 of the first byte of the response code will be ON if a network relay error has occurred. When this happens, two more bytes of data will follow the response code to indicate the location of the error. This information, along with the response code, should enable you to track the error.

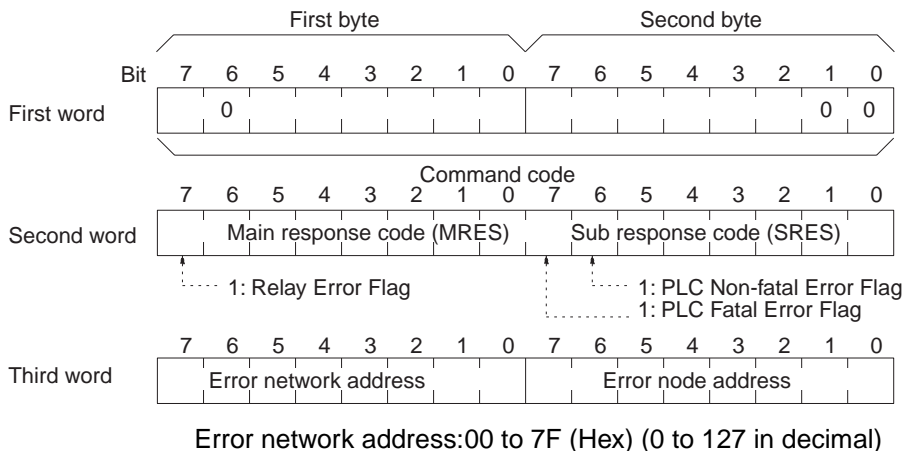

Error node address: Controller Link:01 to 3E (Hex) (1 to 62 in decimal) (*1)
 Ethernet:01 to 7E (Hex) (1 to 126 in decimal)
 SYSMAC NET:01 to 7E (Hex) (1 to 126 in decimal)
 SYSMAC LINK:01 to 3E (Hex) (1 to 62 in decimal)

*1 This is 01 to 20 Hex (1 to 32) for Wired or Optical Bus (CLK11) Controller Link Units.

Relay Errors

A relay error indicates that the command did not reach the Unit to which it was sent. There are several types of situation in which this can occur. Example 1 (below) shows a situation in which a relay error occurs when data cannot be transferred from one Communications Unit to another in an interconnected network. Example 2 shows a similar situation, except that the remote Unit is something other than a Communications Unit. In Example 3, the relay error occurs because either the specified remote node or the next relay node does not exist.

In the three diagrams, the numbers indicate the following:

- (1)The transmitted data fails to be received.
- (2)The relay error and response code are returned to the command source.

Example 1

In this example, data cannot be transferred between Controller Link Units due to some cause such as a routing table error.

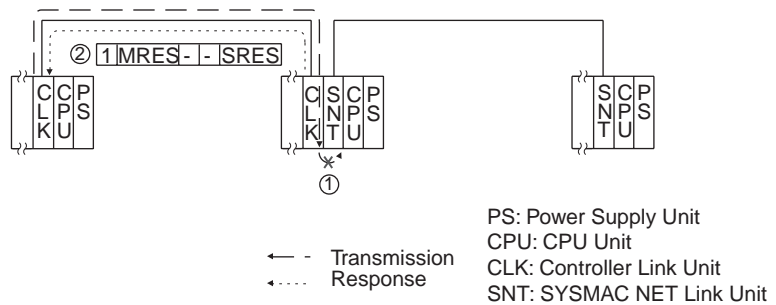

Example 2

In this example, data cannot be transferred between a Controller Link Unit and a CPU Unit.

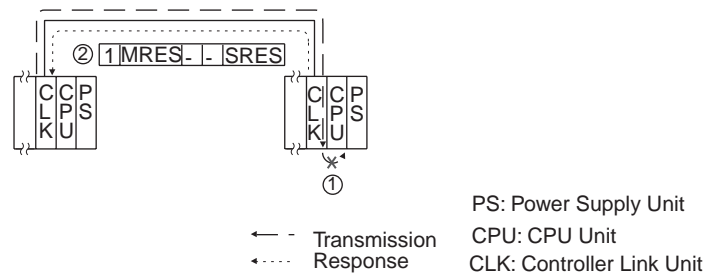

Example 3

In this example, the specified remote node or the next relay node does not exist.

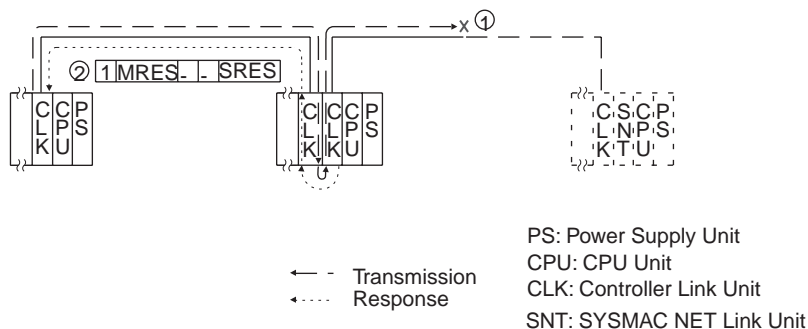

If an error occurs, check the MRES and SRES codes for the node in question, and correct the problem.

6-6-3 Response Codes and Troubleshooting

The table below lists response codes (main and sub-codes) returned after execution of the FINS commands, the probable cause of errors, and recommended remedies.

Upon receipt of some commands, the remote node will issue a request to another node; the other node is referred to as the third node.

Main code	Sub-code	Probable cause	Remedy
00: Normal completion	00	---	---
	01	Service was interrupted	Check the contents of the destination transmission area of third node. Check the data link status.
01: Local node error	01	Local node not part of Network	Add to Network.
	02	Token time-out, node address too large	Set the local node's node address below the maximum node address.
	03	Number of transmit retries exceeded	Check communications with ECHOBACK TEST. If the test fails, check network.
	04	Maximum number of frames exceeded	Either check the execution of events in the network and reduce the number of events occurring in one cycle, or increase the maximum number of frames.
	05	Node address setting error (range)	Correctly set the Controller Link BIOS /N option. Make sure the node address is within specified range and that there are no node addresses that are set twice.
	06	Node address duplication error	Make sure that there are no node addresses that are set twice.

Main code	Sub-code	Probable cause	Remedy
02: Remote node error	01	Remote node not part of Network	Add to Network.
	02	No node with the specified node address	Check the remote node's node address.
	03	Third node not part of Network	Check the third node's node address.
		Broadcasting was specified.	Check the control data and specify only one node as the third node.
	04	Busy error, remote node busy	Increase the number of transmit retry attempts or re-evaluate the system so that the remote node is not so busy receiving data.
	05	Response time-out, message packet was corrupted by noise	Increase the number of transmit retry attempts.
		Response time-out, response watchdog timer interval too short (If a large number of data links is used, the response monitor time will be shorter than the communications cycle time.)	Increase the value for the response watchdog timer interval in the control data.
Frame lost in transmission		Check the error log and correct the process.	
03: Communications controller error	01	Error occurred in the communications controller, ERC indicator is lit	Take corrective action, referring to communications controller errors and remedies table at end of this section
	02	CPU Unit error occurred in the PLC at the remote node	Clear the error in the CPU Unit (refer to the PLC's operation manuals)
	03	A controller error has prevented a normal response from being returned.	Check network communications status and reset the controller board. If the error still exists, replace the controller board.
	04	Unit address setting error	Make sure the Unit address is within the specified range and that there are no node addresses that are set twice.
04: Not executable	01	An undefined command has been used.	Check the command code and be sure that the Unit supports it.
	02	Cannot process command because the specified unit model or version is wrong.	Check the unit model and version.
05: Routing error	01	Remote node address is not set in the routing table.	Set the remote node address in the routing table.
	02	Routing table isn't registered.	Set the local nodes, remote nodes, and relay nodes in the routing table.
	03	Routing table error	Set the routing table correctly.
	04	The maximum number of relay nodes was exceeded in the command.	Redesign the network or reconsider the routing table to reduce the number of relay nodes in the command. Use a CS-series CPU Unit with unit Ver. 2.0 or later with CX-Programmer Ver. 4.0 or later to send commands across three or more network levels.

Main code	Sub-code	Probable cause	Remedy
10: Command format error	01	The command is longer than the max. permissible length.	Check the command format of the command and set it correctly.
	02	The command is shorter than min. permissible length.	Check the command format of the command and set it correctly.
	03	The designated number of data items differs from the actual number.	Check the number of items and the data, and make sure that they agree.
	04	An incorrect command format has been used.	Check the command format of the command and set it correctly.
	05	An incorrect header has been used. (The local node's relay table or relay node's local network table is wrong.)	Set the routing table correctly.
11: Parameter error	01	A correct memory area code has not been used or Extended Data Memory is not available.	Check the command's memory area code and set the appropriate code.
	02	The access size specified in the command is wrong, or the first address is an odd number.	Set the correct access size for the command.
	03	The first address is in an inaccessible area.	Set a first address that is in an accessible area.
	04	The end of specified word range exceeds the acceptable range.	Check the acceptable limits of the data area and set the word range within the limits.
		The total number of words exceeds the acceptable range.	Check the data link tables to be sure the limit to link words has not been exceeded.
	06	A non-existent program no. has been specified.	Check the program number and be sure that it is set correctly.
	09	The sizes of data items in the command block are wrong.	Check the command data and be sure that the sizes of the data items are correct.
		A node that is not set as a common link parameter is in the refresh parameters.	Check the data link tables to be sure all nodes in the refresh parameters are in the common link parameters.
	0A	The IOM break function cannot be executed because it is already being executed.	Either abort the current IOM break function processing, or wait until it is completed and execute the command.
		There are node addresses that have been set twice.	Check the data link tables for node addresses that have been set twice.
	0B	The response block is longer than the max. permissible length.	Check the command format and set the number of items correctly.
	0C	An incorrect parameter code has been specified.	Check the command data and reenter it correctly.
		There is a file error.	Check the data link table file for corruption.

Main code	Sub-code	Probable cause	Remedy
20: Read not possible	02	The data is protected.	Execute the instruction again after issuing the PROGRAM AREA PROTECT CLEAR command to the PLC.
		An attempt was made to download a file that is being uploaded.	Check the file name and either interrupt servicing or wait for servicing to complete before re-executing the command.
	03	The registered table does not exist or is incorrect.	Set or reset the registered table.
		Too many files open.	Close open files and re-execute the command.
	04	The corresponding search data does not exist.	---
	05	A non-existing program no. has been specified.	Check the program number and be sure that it is set correctly.
	06	A non-existing file has been specified.	Check whether the correct file name was used.
	07	A verification error has occurred.	Check whether the memory contents are correct and replace if incorrect.
A read error occurred.		Check the contents of the file.	
21: Write not possible	01	The specified area is read-only or is write-protected.	If the specified area is read-only, the write cannot be performed. If it is write-protected, turn off the write-protect switch and execute the instruction again.
	02	The data is protected.	Execute the instruction again after issuing the PROGRAM AREA PROTECT CLEAR command to the PLC.
		An attempt was made to simultaneously download and upload a file.	Check the file name and either interrupt servicing or wait for servicing to complete before re-executing the command.
		The data link tables cannot be written manual because the Unit is set for automatic generation.	Change the data link mode to manual.
	03	The number of files exceeds the maximum permissible.	Write the file(s) again after erasing unneeded files, or use different disk or Memory Card that has free space.
		Too many files open.	Close open files and re-execute the command.
	05	A non-existing program no. has been specified.	Check the program number and be sure that it is set correctly.
	06	A non-existent file has been specified.	Check the file name and execute again.
07	The specified file already exists.	Change the name of the file and execute the instruction again.	
08	Data cannot be changed.	---	
22: Not executable in current mode	01	The mode is wrong (executing).	Check the operating mode.
		Data links are inactive.	Check the data link status before execution.
	02	The mode is wrong (inactive).	Check the operating mode.
		Data links are inactive.	Check the data link status before execution.
	03	The PLC is in the PROGRAM mode.	Check operating mode of the PLC or computer.
	04	The PLC is in the DEBUG mode.	
	05	The PLC is in the MONITOR mode.	
	06	The PLC is in the RUN mode.	
07	The specified node is not the control node.	Check which node is the control node.	
08	The mode is wrong and the step cannot be executed.	Check whether the step has active status or not.	

Main code	Sub-code	Probable cause	Remedy
23: No Unit	01	A file device does not exist where specified.	Mount the Memory Card or disk
	02	The specified memory does not exist.	Check the specifications of the installed file memory.
	03	No clock exists.	Check the model number.
24: Start/stop not possible	01	The data link tables either have not been created or are incorrect.	Set the data link tables correctly.
25: Unit error	02	Parity/checksum error occurred because of incorrect data.	Transfer correct data into memory.
	03	I/O setting error (The registered I/O configuration differs from the actual.)	Either change the actual configuration to match the registered one, or generate the I/O table again.
	04	Too many I/O points	Redesign the system to remain within permissible limits.
	05	CPU bus error (An error occurred during data transfer between the CPU Unit and a CPU Bus Unit.)	Check the Unit, Service Boards, and cable connections and issue the ERROR CLEAR command.
	06	I/O duplication error (A rack number, unit number, or I/O word allocation has been duplicated.)	Check the system's settings and eliminate any settings that occur twice.
	07	I/O bus error (An error occurred during data transfer between the CPU Unit and an I/O Unit.)	Check the Unit, Service Boards, and cable connections and issue the ERROR CLEAR command.
	09	SYSMAC BUS/2 error (An error occurred during SYSMAC BUS/2 data transfer.)	Check the Unit, Service Boards, and cable connections and issue the ERROR CLEAR command.
	0A	Special I/O Unit error (An error occurred during CPU Bus Unit data transfer.)	Check the Unit, Service Boards, and cable connections and issue the ERROR CLEAR command.
	0D	Duplication in SYSMAC BUS word allocation.	Check and regenerate the I/O table.
	0F	A memory error has occurred in internal memory, in the Memory Card, or in Expansion DM during the error check.	If the error occurred in internal memory or the EM Unit, correct the data in the command and execute it again. If the error occurred in a Memory Card or EM used for file memory, the file data has been corrupted. Execute the MEMORY CARD FORMAT command for the PLC. If the above remedies do not eliminate the error, replace the faulty memory.
10	Terminator not connected in SYSMAC BUS System.	Connect the terminator correctly.	

Main code	Sub-code	Probable cause	Remedy
26: Command error	01	The specified area is not protected. This response code will be returned if an attempt is made to clear protection on an area that is not protected.	The program area is not protected, so it isn't necessary to clear protection.
	02	An incorrect password has been specified.	Specify a password that is registered.
	04	The specified area is protected.	Execute the command again after executing the PROGRAM AREA PROTECT CLEAR command for the PLC.
		The destination has received more than 5 commands.	Either interrupt servicing or wait for servicing to complete before re-executing the command.
	05	The service is being executed.	Execute the command again after the service has been completed or aborted.
	06	The service is not being executed.	Execute the service if necessary.
	07	The node does not have the right to execute the service.	Service cannot be executed from local node because the local node is not part of the data links. Execute the service from a node that is part of the data links.
		A buffer error has prevented returning a normal response.	Reset the board. If the error persists, replace the board.
	08	Service cannot be executed because necessary settings haven't been made.	Make the necessary settings.
	09	Service cannot be executed because necessary settings haven't been made in the command data.	Check the command format of and make the necessary settings.
	0A	The specified action or transition number has already been registered.	Execute the command again using an action or transition number that hasn't been registered.
	0B	Cannot clear error because the cause of the error still exists.	Eliminate the cause of the error and execute the ERROR CLEAR command.
30: Access right error	01	The access right is held by another node. (Either a Programming Device at the other node is executing an SFC online edit, or the other node is executing an ACCESS RIGHT ACQUIRE or ACCESS RIGHT FORCED ACQUIRE command.)	Execute the command again after the access right has been released. (The command can be executed after the ACCESS RIGHT FORCED ACQUIRE or ACCESS RIGHT RELEASE command is completed. Releasing the access right might affect processes in progress at the node that held the access right.)
40: Abort	01	Command was aborted with ABORT command.	---

SECTION 7

Network Interconnections

This section describes the methods used to connect multiple networks through CS-series, CVM1, and CV-series PLCs. The section also describes remote programming and monitoring with Programming Devices.

7-1	What is Network Interconnection?	186
7-1-1	Interconnecting Controller Link Networks	186
7-1-2	Interconnecting Different Types of Networks	186
7-2	Remote Programming and Monitoring	188
7-2-1	Within the Same Network	188
7-2-2	Remote Controller Link Networks	189
7-2-3	Other Remote Networks	190
7-3	Routing Tables	190
7-4	Setting Routing Tables	192
7-4-1	Routing Table Setting Procedure	192
7-4-2	Editing Local Network Tables	193
7-4-3	Editing Relay Network Tables	193
7-4-4	Saving Routing Tables	194
7-4-5	Connecting to the PLC	194
7-4-6	Transferring Routing Tables	194
7-4-7	Example Routing Table Settings	194

7-1 What is Network Interconnection?

Network interconnection enables commands and responses for the message service to be sent and received across multiple networks. The four networks listed below can be interconnected to achieve this.

FA Networks

- SYSMAC NET Link Networks
- SYSMAC LINK Networks
- Controller Link Networks

OA Network

- Ethernet Networks

7-1-1 Interconnecting Controller Link Networks

Controller Link Networks can be connected through a CS-series, CVM1, or CV-series PLC.

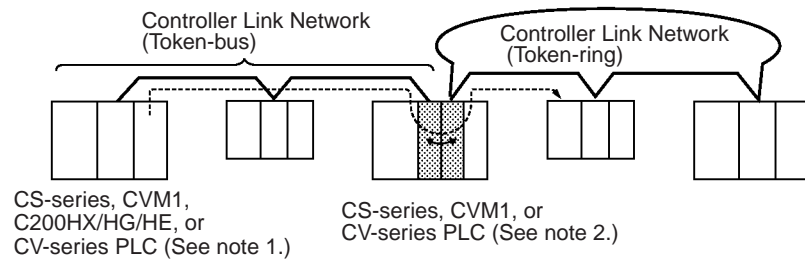

- Note**
1. Only the token-bus mode can be used with the C200HX/HG/HE Series.
 2. A data bridge is created between Controller Link Units mounted on the same CS-series, CVM1, or CV-series PLC.

7-1-2 Interconnecting Different Types of Networks

A CS-series, CVM1, or CV-series PLC can be used to connect a Controller Link Network with an Ethernet, SYSMAC NET, or SYSMAC LINK Network.

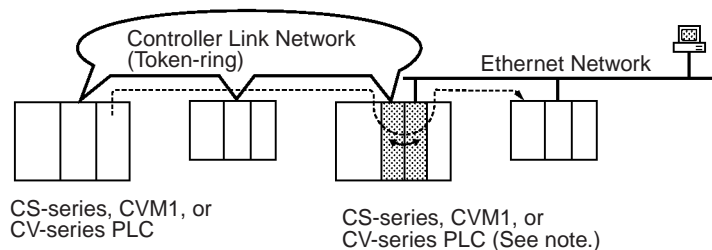

Note A data and communications protocol gateway is created between a Controller Link Unit and an Ethernet, SYSMAC NET, or SYSMAC LINK Unit mounted to the same CVM1, CV-series PLC.

- Note**
1. A bridge is used between Communications Units to connect the same type of networks.

2. A gateway is used between Communications Units to connect different types of networks.

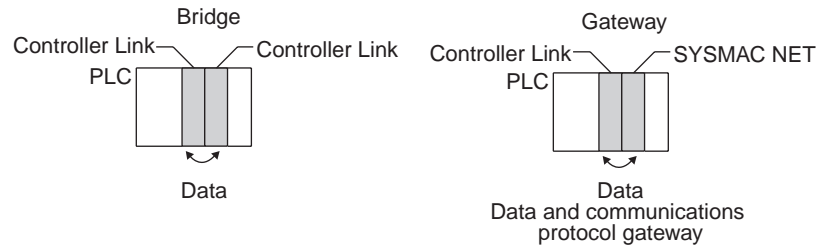

- Communications across up to eight networks, including the local network are possible when using a CS-series CPU Unit with unit version 2.0 or later. The following conditions and restrictions apply.
 - The CPU Unit for all nodes must be a CS-series CPU Unit with unit version 2.0 or later.
 - Routing tables can be set using the CX-Net in the CX-Programmer version 4.0 or later.
 - Communications across up to eight networks away are supported by Controller Link and Ethernet networks only.
 - DeviceNet and SYSMAC LINK networks support communications across up to three networks, the same as earlier versions.

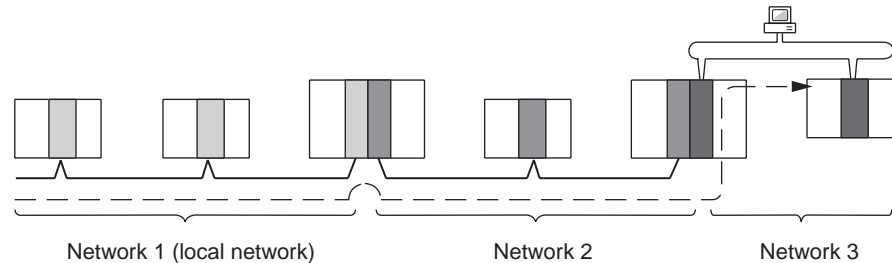

Although 2,012 bytes of data (including the header) can be sent and received with a Controller Link, the maximum amount of data is limited by any network the data passes through, i.e., the network with the smallest capacity will determine the limit.

If, for example, data passes through a SYSMAC LINK network as shown in the figure on the preceding page, the amount of data sent and received from the Controller Link is limited to 552 bytes (including the header) because the SYSMAC LINK Network can only handle that many bytes.

See the manual for the network you are using in order to determine the maximum amount of data for each network.

7-2 Remote Programming and Monitoring

A remote PLC can be programmed and monitored across a network from a Programming Device connected to a PLC.

7-2-1 Within the Same Network

SYSMAC Support Software and CV Support Software

A Programming Device connected to a CVM1, or CV-series CPU Unit can program and monitor a CVM1, or CV-series PLC on the same network. Programming and monitoring are possible, however, only for the same type of CPU Unit as the one to which the Programming Device is connected. For example, if the Programming Device is connected to a CVM1 or CV-series PLC, you can only program and monitor CVM1 or CV-series PLCs on the network.

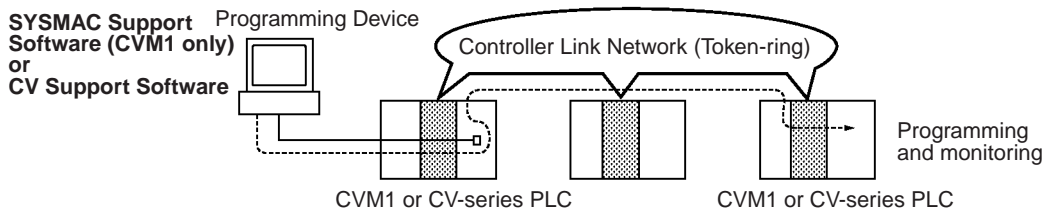

Note Remote programming and monitoring is not possible from a personal computer used as a node. Computer nodes can only monitor Controller Link Network status.

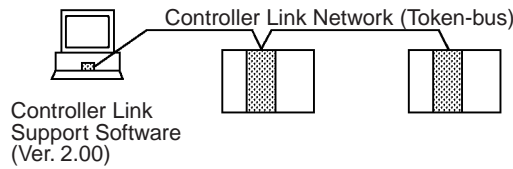

CX-Programmer

A CX-Programmer connected to a CS-series, C200HX/HG/HE, CVM1, CV-series, or CQM1H CPU Unit can program and monitor a CPU Unit on the same network. Programming and monitoring are possible, including CPU Units that are different to the one to which the Programming Device is connected.

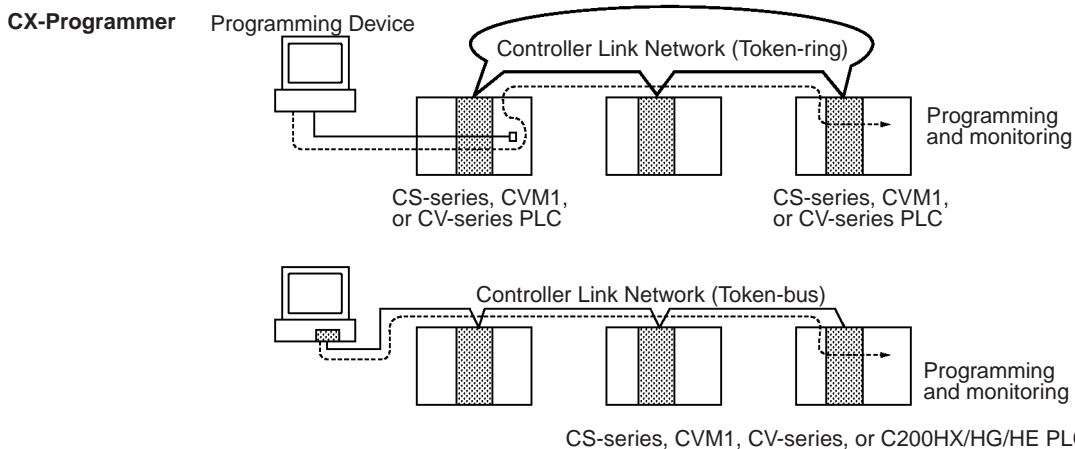

- Note**
1. With CX-Programmer, remote programming and monitoring are possible from a personal computer used as a node.
 2. C200HX/HG/HE PLCs can only be used in token-bus mode (wired).

7-2-2 Remote Controller Link Networks

SYSMAC Support Software or CV Support Software

A Programming Device connected to a CVM1 or CV-series CPU Unit can program and monitor a CVM1 or CV-series PLC on another Controller Link Network through a CVM1 or CV-series PLC. Other types of PLC cannot be programmed or monitored on remote networks.

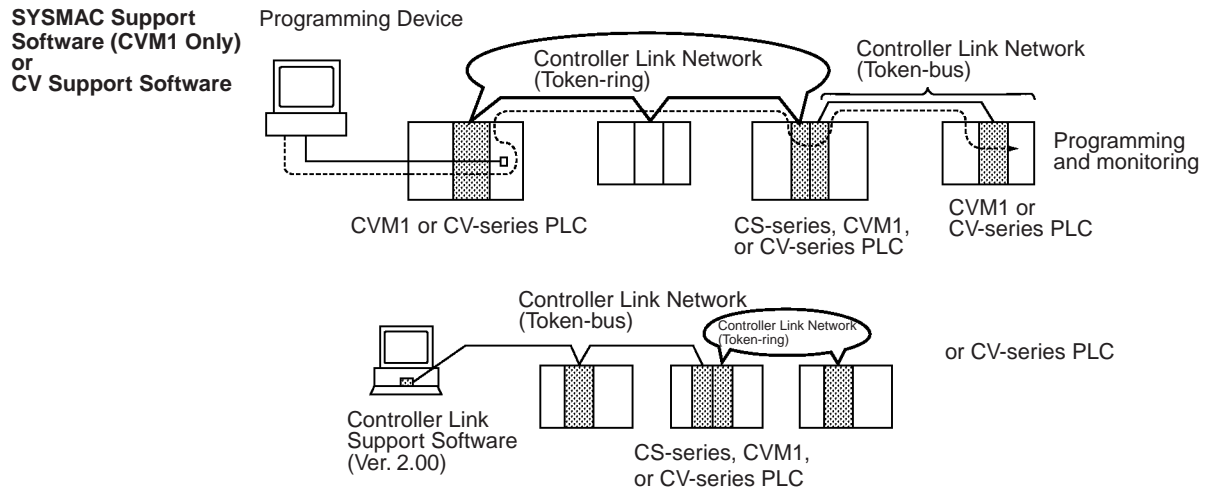

- Note**
1. Remote programming and monitoring is not possible from a personal computer used as a node. Computer nodes can only monitor Controller Link Network status.
 2. A Programming Device connected to a C200HX/HG/HE PLC cannot remotely program or monitor a node on a remote network.

CX-Programmer

A CX-Programmer connected to a CS-series, CVM1, CV-series, or CQM1H-series CPU Unit can program and monitor any other PLC on another Controller Link Network. Other types of PLC, different to the one to which the CX-Programmer is connected can also be programmed or monitored on remote networks.

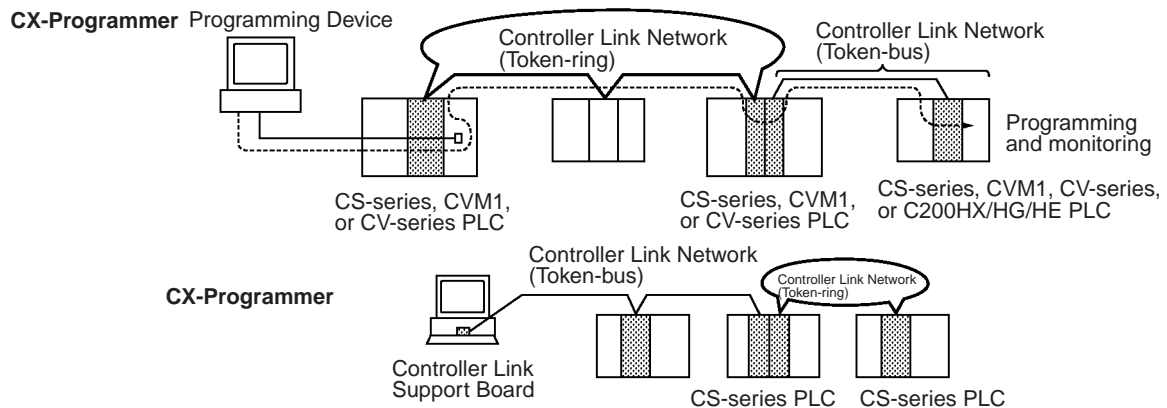

- Note**
1. With CX-Programmer, remote programming and monitoring is possible from a personal computer used as a node.
 2. C200HX/HG/HE PLCs can only be used in token-bus mode (wired).

7-2-3 Other Remote Networks

SYSMAC Support Software or CV Support Software

A Programming Device connected to a CVM1 or CV-series CPU Unit can program and monitor a CVM1 or CV-series PLC on a different type of network (SYSMAC NET or SYSMAC LINK) through a CVM1 or CV-series PLC. Other types of PLC cannot be programmed or monitored on remote networks.

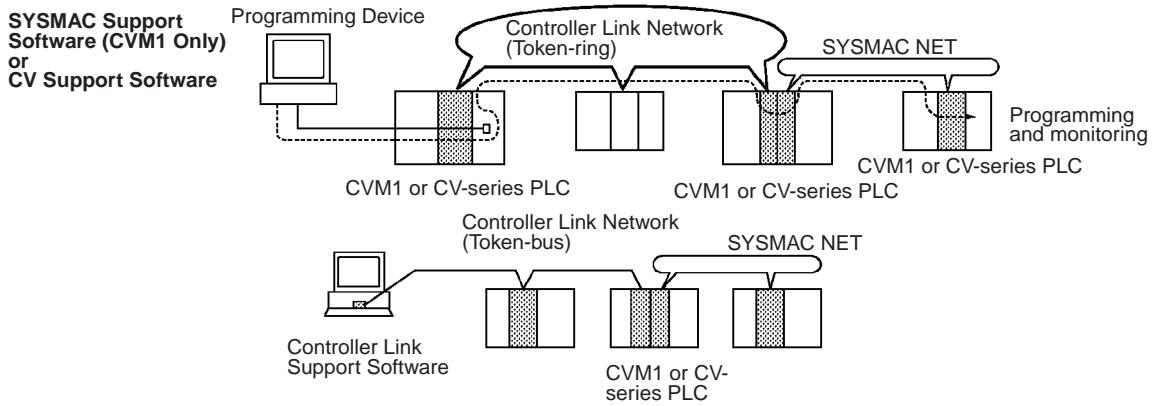

- Note**
1. Remote programming and monitoring is not possible from a personal computer used as a node. Computer nodes can only monitor Controller Link Network status.
 2. A Programming Device connected to a C200HX/HG/HE PLC cannot remotely program or monitor a node on a remote network.

CX-Programmer

A CX-Programmer connected to a CS-series, CVM1, or CV-series CPU Unit can program and monitor any other PLC on a different type of network (Ethernet, SYSMAC NET, or SYSMAC LINK) through a CS-series, CVM1, or CV-series PLC.

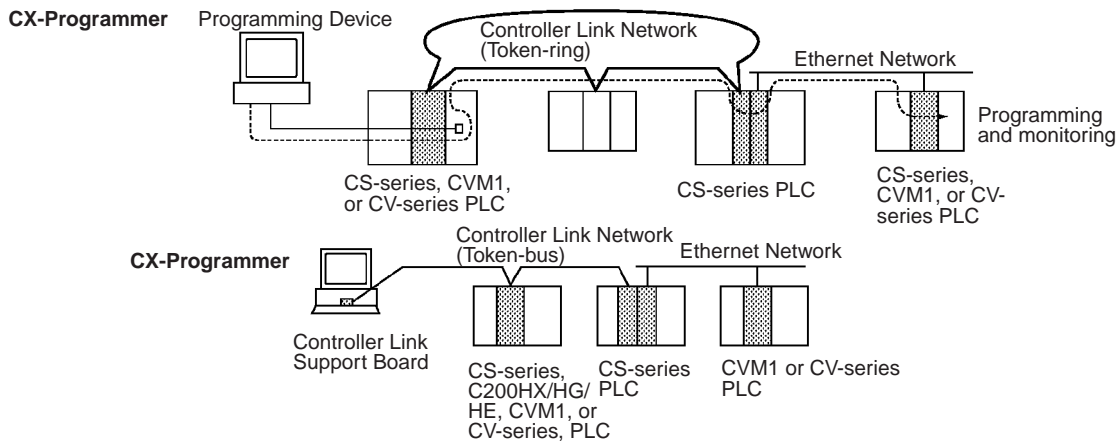

- Note**
1. With CX-Programmer, remote programming and monitoring is possible from a personal computer used as a node.
 2. C200HX/HG/HE PLCs can only be used in token-bus mode (wired).

7-3 Routing Tables

Routing tables that define the communications path from the Controller Link Unit on the local PLC to the network connected to the destination PLC must be created in order to send and receive data across networks. Each CPU Unit implements the message service or remote programming/monitoring to the appropriate Unit according to the routing tables.

Creating Routing Tables

Routing tables consists of a local network table and a relay network table.

Local Network Table

A local network table provides unit numbers and network addresses corresponding to the Units mounted to the PLC.

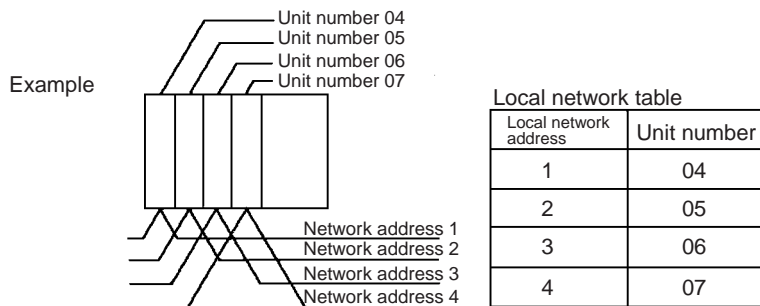

- Note**
1. The unit number is set between 0 and 15 using the rotary switch on the front panel of Controller Link Units for CS-series, CVM1, and CV-series PLCs.
 2. The network address is the address of the network connected to the Unit (between 1 and 127). The address is set when the local network table is created.

Relay Network Table

A relay network table provides the node and network addresses corresponding to the initial relay point (first point the data must go to) en route to a target network (end network) not directly connected to the local PLC.

The table traces the route from the relay point to the end network.

The example below shows the routing tables for the route from local node PLC1 (network address 1, node address 1) to PLC4 (network address 3, node address 2).

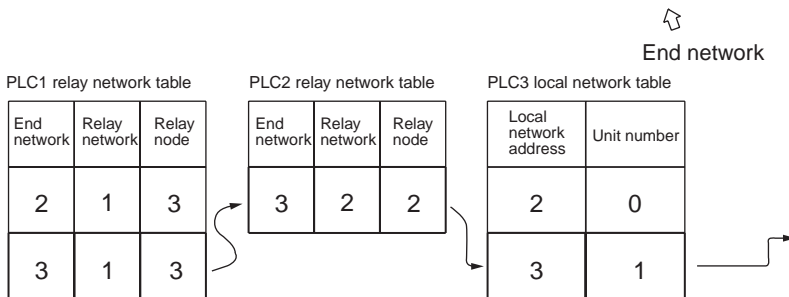
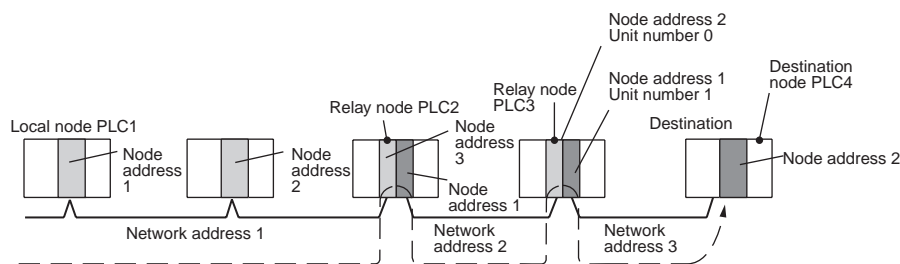

Data first goes to node address 3 at network address 1 to reach network address 3.

Data then goes to node address 2 at network address 2 to reach network address 3.

We know from the local network table that the data goes through local unit number 1 to reach network address 3.

Data goes to node address 2 at network address 3, i.e., the local network.

- Note**
1. The above example shows the routing tables for sending a message from PLC1 to PLC4. Similar routing table entries would have to be added to send a message from PLC4 to PLC1.
 2. Refer to 7-4 *Setting Routing Tables* for an example of setting routing tables.

7-4 Setting Routing Tables

This section describes routing table settings.

Routing tables are set through the CX-Net (in CX-Programmer), SYSMAC LINK, or Controller Link Support Software. This section describes setting procedures and setting details.

See the operating manual of the Programming Device you are using for the specific setting procedure.

- Note**
1. Routing tables cannot be set through Programming Consoles.
 2. Networks cannot be crossed by a Programming Device without setting routing tables. Routing tables can therefore be set only for nodes connected to the Programming Device and other nodes in the same network. Disconnect and reconnect the Programming Device to each network when setting routing tables in multiple networks.
 3. Make sure that the routing tables are properly set at all nodes on the network. If a message is sent to a node without correct routing tables, transmission will not work properly and a response may not be returned.
 4. When using a CVM1 or CV-series CPU Unit manufactured prior to April 1996, be sure to register routing tables whether or not the PLC is connecting multiple networks. The date of production can be checked on the lot number as explained below. (The lot number is a four-digit number written on the side panel of the CPU Unit.)

Note Routing tables are required if any of the CVM1 or CV-series CPU Units in the network have been manufactured on or before April 1996.

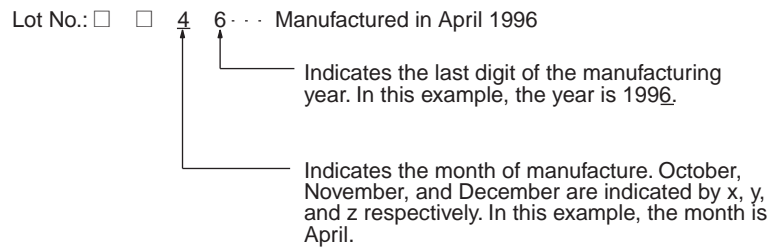

7-4-1 Routing Table Setting Procedure

The procedure for setting routing tables is described below.

- 1,2,3...**
1. Edit the local network table.
 2. Edit the relay network table.
 3. Save the routing tables.
 4. Connect the Programming Device to a PLC.
 5. Transfer the routing tables.
- Repeat the editing and saving steps for all nodes set with the routing tables.

7-4-2 Editing Local Network Tables

Use the routing table editing function on the Programming Device to edit the local network table as shown on the screen given below.

[Local Network table]

No.	Loc Netwk	SIOU unit #	No.	Loc Netwk	SIOU unit #
1			9		
2			10		
3			11		
4			12		
5			13		
6			14		
7			15		
8			16		

Local network:

Address 1 through 127 for the network connected to the Communications Unit

SIOU Unit No.:

Unit number of the Communications Unit. (CS-series, CVM1, or CV-series: 0 to 15) Set the unit number of all Communications Units (SYSMAC NET Link Units, SYSMAC Link Units and Controller Link Units) as well as the address of network connected to it.

Be sure to set the same address for each network when setting routing tables (local and relay network tables) in multiple PLCs.

7-4-3 Editing Relay Network Tables

Use the routing table editing function on the Programming Device to edit the local network table as shown on the screen given below.

[Relay Network table]

No.	End Netwk	Relay			No.	End Netwk	Relay		
		PC ID	Netwk	node			PC ID	Netwk	node
1					11				
2					12				
3					13				
4					14				
5					15				
6					16				
7					17				
8					18				
9					19				
10					20				

End network:

Network address of the end network (1 through 127)

Relay network:

Network address of the first relay point on the way to the end network (1 through 127)

Relay node:

Node address of the first relay point on the way to the end network (SYSMAC NET: 1 through 126, SYSMAC LINK: 1 through 62, and Controller Link (Wired or Optical Bus): 1 through 32, Ethernet: 1 through 127)

Set all networks not directly connected to the PLC.

Be sure to set the same address for each network when setting routing tables (local and relay network tables) in multiple PLCs.

Note The PLC ID is any unique name given to a specific node. When setting the PLC ID, simply input the ID. Network and node addresses will be input for you automatically. See the operation manual for SYSMAC, CV, or Controller Link Support Software for further details.

7-4-4 Saving Routing Tables

After editing local and relay network tables on the Programming Device, save the tables.

Note When setting routing tables in multiple PLCs, edit and save all routing tables and then transfer them together to work more efficiently.

7-4-5 Connecting to the PLC

Connect the Programming Device to a PLC in the network to transfer the routing tables. All PLCs receiving the routing table settings must have power turned ON for the transfer.

Note The Programming Device must be disconnected and then reconnected to a PLC on each network.

7-4-6 Transferring Routing Tables

Routing tables saved on a Programming Device can be read from memory and transferred to the PLCs on the network. First load and transfer routing tables to the PLC connected to the Programming Device. This enables networks to be distinguished even when multiple Communications Units are connected, and it enables routing tables to be transferred to other nodes on the network.

Once routing tables are transferred to the PLC connected to the Programming Device as well as all nodes on the same network, disconnect the Programming Device, reconnect it to a PLC on another network, and repeat the procedure.

 **Caution** CPU Bus Units are reset when routing tables are transferred from a Programming Device to a PLC to allow set routing tables to be read. Make sure that resetting CPU Bus Units will not cause equipment damage or dangerous system behavior before transferring tables.

7-4-7 Example Routing Table Settings

This section shows examples of routing table settings.

Example 1

The example below shows local network table settings when multiple CPU Bus Units are mounted in a single CVM1 or CV-series PLC.

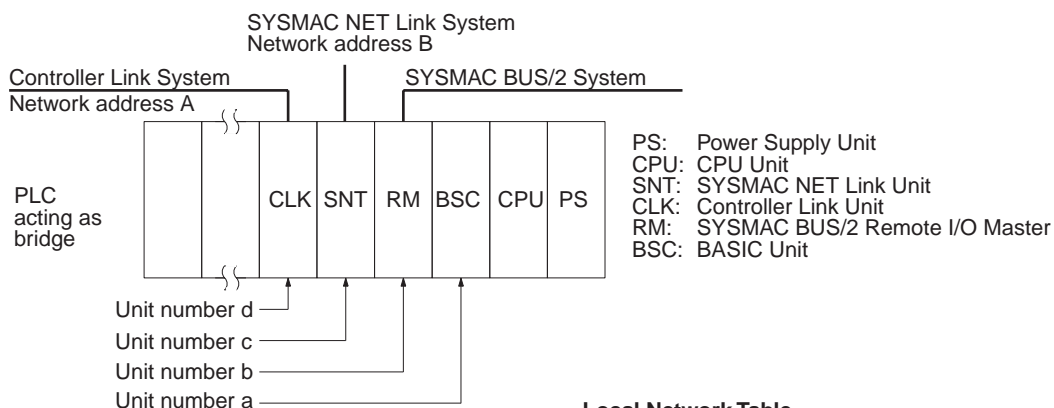

Local Network Table

No.	Loc Netwk	SIOU unit #
1	A	(d)
2	B	(c)

Do not register SYSMAC BUS/2 Master Units and BASIC Units in local network tables because these Units do not connect to networks.

Example 2

The following example show the settings for a relay network table connecting three networks.

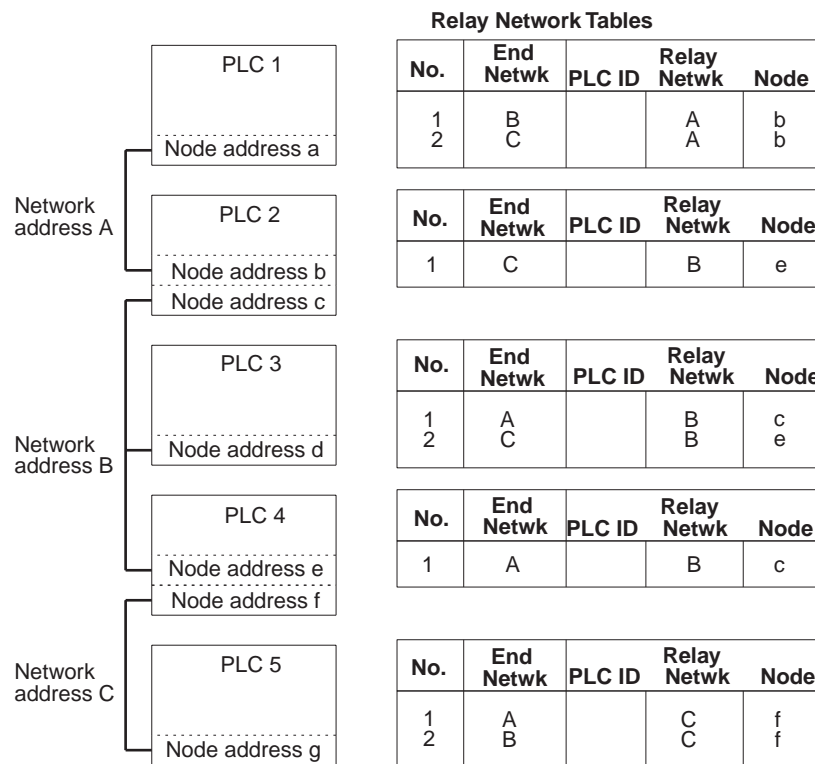

On closer examination of the relay network table for PLC3, we see that the relay network is B and the relay node is c when network A is the destination, and that the relay network is B and the relay node is e when network C is the destination.

Example 3

The network structure example in the figure below shows routing tables for all nodes.

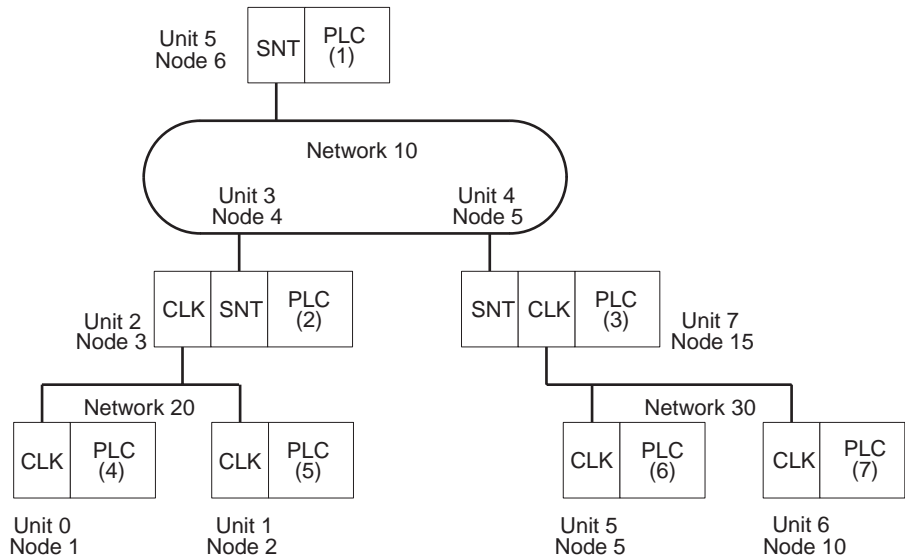

Routing Tables on PLC 1

Local Network Table

No.	Loc Netwk	SIOU unit#
1	010	05
2		
3		

Relay Network Table

No.	End Netwk	PLC ID	Relay Netwk	Node
1	020		010	004
2	030		010	005
3				

Routing Tables on PLC 2

Local Network Table

No.	Loc Netwk	SIOU unit#
1	010	03
2	020	02
3		

Relay Network Table

No.	End Netwk	PLC ID	Relay Netwk	Node
1	030		010	005
2				
3				

Routing Tables on PLC 3

Local Network Table

No.	Loc Netwk	SIOU unit#
1	010	04
2	030	07
3		

Relay Network Table

No.	End Netwk	PLC ID	Relay Netwk	Node
1	020		010	004
2				
3				

Routing Tables on PLC 4

Local Network Table

No.	Loc Netwk	SIOU unit#
1	020	00
2		
3		

Relay Network Table

No.	End Netwk	PLC ID	Relay Netwk	Node
1	010		020	003
2	030		020	003
3				

Routing Tables on PLC 5

Local Network Table

No.	Loc Netwk	SIOU unit#
1	020	01
2		
3		

Relay Network Table

No.	End Netwk	PLC ID	Relay Netwk	Node
1	010		020	003
2	030		020	003
3				

Routing Tables on PLC 6

Local Network Table

No.	Loc Netwk	SIOU unit#
1	030	05
2		
3		

Relay Network Table

No.	End Netwk	PLC ID	Relay Netwk	Node
1	010		030	015
2	020		030	015
3				

Routing Tables on PLC 7

Local Network Table

No.	Loc Netwk	SIOU unit#
1	030	06
2		
3		

Relay Network Table

No.	End Netwk	PLC ID	Relay Netwk	Node
1	010		030	015
2	020		030	015
3				

SECTION 8

Duplex Communications Units

This section describes the duplex function for Communications Units. It also provides setting methods using the CX-Programmer and precautions for using Communications Units in duplex operation. Read this section thoroughly and be sure that you understand the contents before using Communications Units in duplex operation.

8-1	Overview	200
8-1-1	Communications Continuation for Controller Link Unit Errors . . .	200
8-1-2	Online Replacement.	202
8-2	Duplex Unit System Configuration	202
8-2-1	System Configuration.	202
8-2-2	Duplex Specifications	203
8-3	Procedure for Using Duplex Units	204
8-3-1	Overview	204
8-3-2	Duplex Settings in the PLC Setup	207
8-3-3	Creating I/O Tables for Duplex Systems	208
8-4	Precautions for Duplex Systems.	210
8-5	Switching Time for Duplex Units	212
8-6	Auxiliary Area Bits/Words and PLC Setup Settings Related to Duplex Communications Units	214
8-6-1	Auxiliary Area	214
8-6-2	PLC Setup	216

8-1 Overview

By mounting the CS-series Optical Ring Controller Link Units (CS1W-CLK13/12-V1 or CS1W-CLK53/52-V1) to the CS1D System, Controller Link Units can be used in duplex operation. The duplex function for Communications Units is used in token-ring mode.

- Note**
1. Use duplex communications systems in token-ring mode. Token-ring mode's transmission path duplication and the CS1D System's duplex function for Communications Units allow the creation of a highly reliable network. If used in token-bus mode, the network will be temporarily split into two networks when Controller Link Units are replaced online because the transmission path is not duplicated.
 2. If an error occurs in an active Controller Link Unit and there is an active/standby switchover, or if an active Controller Link Unit is replaced online, because the relevant node will temporarily leave and then re-enter the network, communications operations (both message communications and data links) will be temporarily stopped. At this time, the Data Link Participation Flag for the relevant node will turn OFF, and the Communications Error Flag will turn ON. After the switchover, communications will resume and everything will return to the normal state (the Data Link Participation Flag turns ON and the Communications Error Flag turns OFF). For this reason, perform the following processing in systems where there are duplex nodes in the network.
 - When using message communications, set the number of retries for the SEND, RECV, and CMND instructions (i.e., set the number of retries in the control data to a value other than 0), and be sure to perform resend processing for instructions.
 - When using data links, while communications operations are stopped, data will not be sent or received for the relevant node. (Data sent or received, however, via data link immediately before communications stopped will be saved.) Therefore, if necessary for the application, include processing to control whether data received via data link after communications resumes (i.e., when the Data Link Participation Flag changes from OFF to ON and the Communications Error Flag changes from ON to OFF) is enabled or not. (Include processing in the ladder programs for the CPU Units at the relevant node and the data link destination node).

A theoretical value for the time required for communications to resume can be obtained using an equation. (Refer to *8-5 Switching Time for Duplex Units*.)

8-1-1 Communications Continuation for Controller Link Unit Errors

By using Duplex Controller Link Units, if there is an error in one of the Controller Link Units that causes it to stop operation, the other Controller Link Unit can continue communications.

Overview

Set the same unit number and node address for a Controller Link Unit mounted to the same CS1D System.

Normal Operation

Normally, one Unit performs communications operations in active mode. The other Unit waits in standby mode without participating in the network. The standby Controller Link Unit continuously performs internal self-diagnosis.

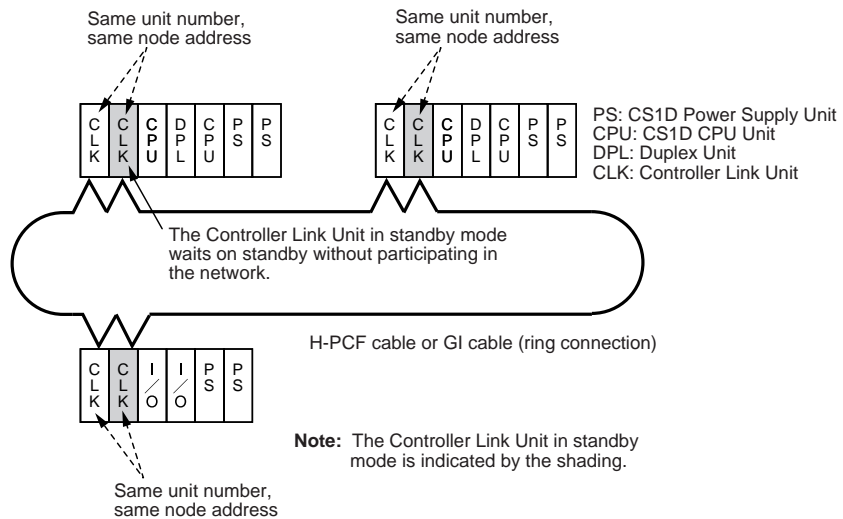

When the Controller Link Network is in normal duplex operation, the corresponding Duplex Communications Unit Operating Flag (A02700 to A02715: bits 00 to 15 correspond to the unit number) in the CS1D CPU Unit turns ON.

Operation when Error Occurs

If an error occurs in the active Controller Link Unit, the standby Controller Link Unit switches to active mode and continues communications for that node.

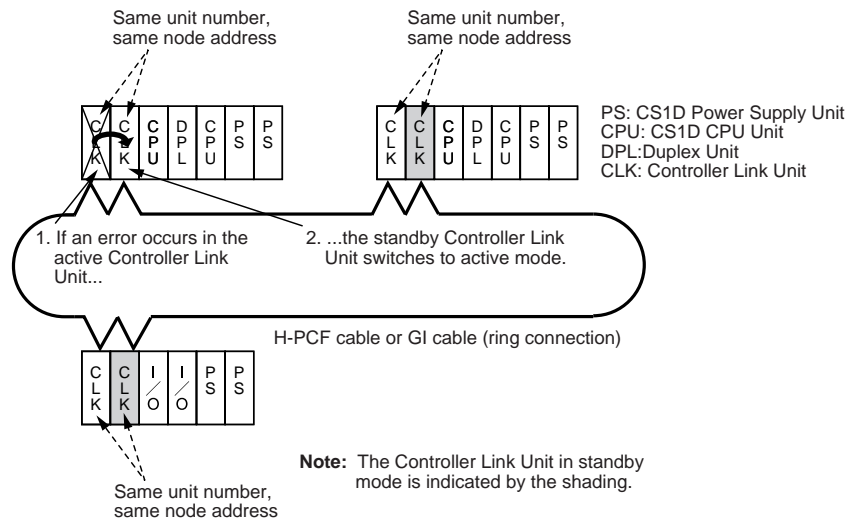

- The standby Controller Link Unit will switch to active mode when the following errors occur in the active Controller Link Unit.
 - a. Error in the communications controller's transmitter
 - b. Hardware error in the communications controller
 - c. EEPROM error
 - d. Watchdog timer error in the Controller Link Unit
 - e. Online replacement of an active Unit

Operation will not switch over if a disconnection due to a transmission path error (e.g., cable or connector break) is detected. Transmission path duplication in token-ring mode allows communications operation to continue in the event of a transmission path error.

If there is an active/standby switchover due to one the reasons above, a duplex communications error is detected at the CPU Unit, and the corresponding Duplex Communications Switched Flag (A43600 to A43615: bits 00 to 15 correspond to the unit number) turns ON. The reason for the switch is recorded in the Duplex Communications Switch Cause Flags (A042 to A049).

- If an error is detected in the standby Controller Link Unit by self-diagnosis, a duplex communications error is detected at the CPU Unit, and the corresponding Duplex Communications Standby Unit Error Flag (A43700 to A43715: bits 00 to 15 correspond to the unit number) turns ON. The active Unit will continue to operate normally and communications will continue. There will be no active/standby switchover.

8-1-2 Online Replacement

In CS1D Systems, a Controller Link Units with an error can be replaced without turning OFF the PLC's power supply (online replacement). For details on the procedure for online replacement, refer to page 294.

Replacing a standby Controller Link Unit has no effect on communications.

When an active Controller Link Unit is replaced, there is an active/standby switchover. The relevant node will temporarily leave and then re-enter the network and communications operations will be temporarily stopped. For details on the time required for communications to resume, refer to *8-5 Switching Time for Duplex Units*.

Note The online replacement procedure is performed from a Programming Console.

8-2 Duplex Unit System Configuration

8-2-1 System Configuration

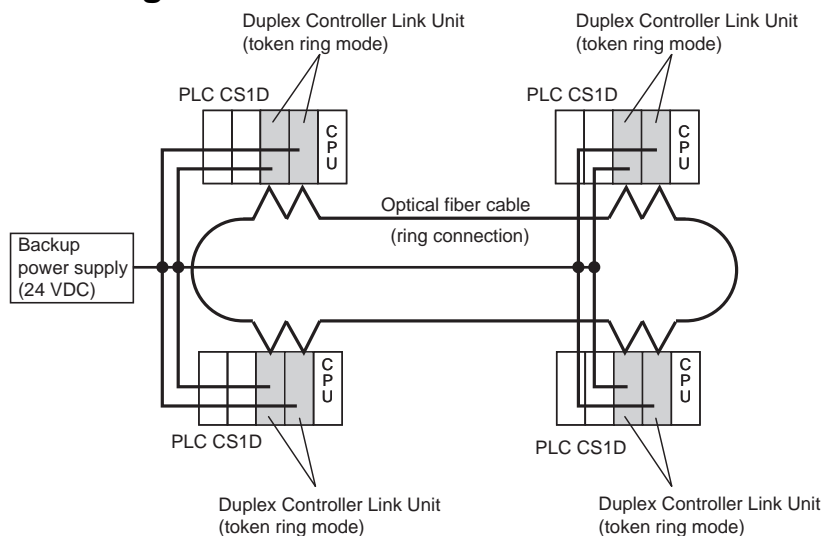

The Controller Link Units can be duplexed by combining a CS1D System and the following Duplex-compatible Controller Link Units.

Unit	Model
Duplex-compatible Controller Link Unit	CS1W-CLK13, CS1W-CLK53, CS1W-CLK12-V1, CS1W-CLK52-V1

- Note**
1. CS1D Systems require special CPU Units, Backplanes, and Power Supply Units. For details, refer to the *CS-series Duplex System Operation Manual* (W405).
 2. When using duplex Communications Units, use the duplex Controller Link Units shown in the illustration above. Duplex operation is not possible with other Units.
 3. In CS1D Systems with Controller Link Units used in duplex operation, set the duplex node as a startup node for data links (Data Link Start/Stop Bit in the CS1D System CPU Unit is turned ON). If the duplex node is not set to be a startup node for data links (Data Link Start/Stop Bit in the CS1D System CPU Unit is OFF), and the relevant node is operating as a polling node, the network's data links may stop if an ACT/STB (active/standby) switchover error occurs.

8-2-2 Duplex Specifications

Specifications relating to duplex functionality are given below. For other specifications, refer to *1-2 Specifications and Configurations*.

Item	Specification
Duplex-compatible model numbers	CS1W-CLK13 (H-PCF cable) CS1W-CLK12-V1 (H-PCF cable) CS1W-CLK53 (GI cable) CS1W-CLK52-V1 (GI cable)
Maximum number of nodes	Up to 31 nodes if all nodes are duplex. In 1 network, a total of up to 62 active and standby Controller Link Units can be connected. (See note 1.)
Number of duplex-compatible Units that can be mounted to 1 CS1D PLC	6 Up to 3 active and 3 standby Units can be mounted. (See note 2.)
Mounting position of duplex-compatible Units	Can be mounted in any slot on a CPU Backplane or Expansion Backplane in a CS1D System. When using a connecting cable (CS1D-CN051) between Duplex Units, however, the cable length is 50 cm and so mount in adjacent slots.

- Note**
1. Although standby Controller Link Units do not participate in the network as nodes, they are physically connected to the network and so they are included in the figure for the maximum number of connectable Units. For this reason, up to a total of 62 active and standby Controller Link Units can be connected. Therefore, if all the nodes are used in the CS1D System, with all the Controller Link Units used in duplex operation, the maximum number of nodes is 31 (62 – Number of standby Controller Link Units).

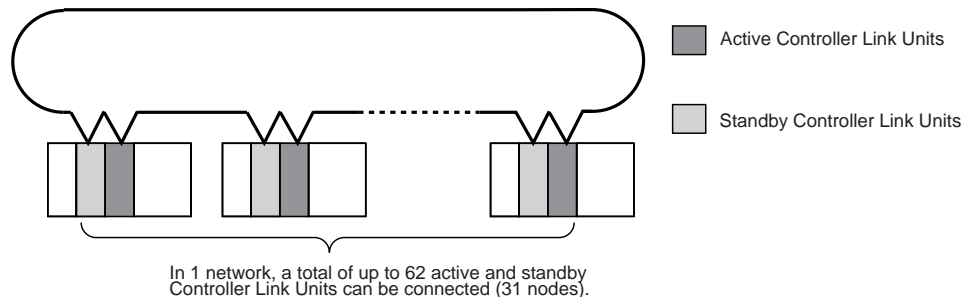

It is also possible to use only some of the Units in the Controller Link Network in duplex operation. In this case, up to a total of 62 active and standby Controller Link Units and Controller Link Units that are not used in duplex operation can be connected. The Units that are not used in duplex operation can include both existing Units (CS1W-CLK12, CS1W-CLK52, CVM1-CLK12, or CVM1-CLK52) and duplex-compatible Units.

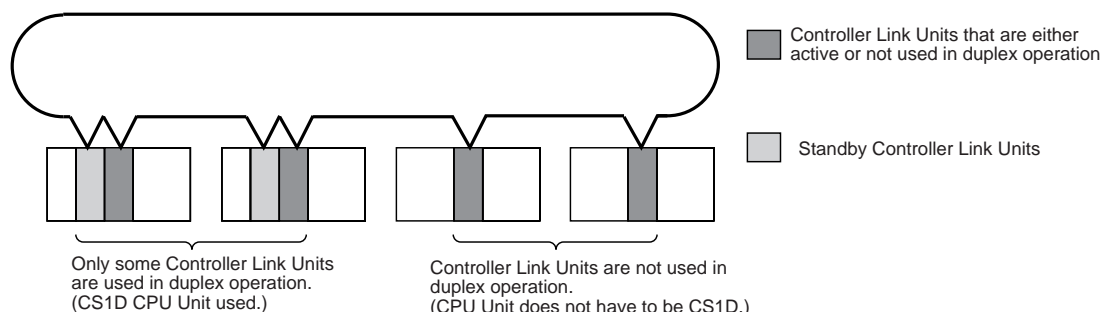

- Up to 3 pairs (i.e., 6 Units) of Duplex Controller Link Units can be mounted to one CS1D PLC. The following table gives the maximum number of mountable Units for different Unit combinations.

Number of Duplex Units mounted (ACT Mode + STB Mode)	Maximum number of non-duplex Units mounted	Total number of Units
None	8 (4)	8 (4)
1 group (2 Units)	7 (3)	9 (5)
2 groups (4 Units)	6 (2)	10 (6)
3 groups (6 Units)	5 (1)	11 (7)

The numbers in parentheses indicate the Pre-Ver. 1.2 models.

8-3 Procedure for Using Duplex Units

8-3-1 Overview

- Mount the two Controller Link Units to be used in duplex operation to the CS1D System.

Note As long as the two Units are mounted to the same CS1D PLC, they can be mounted in non-adjacent slots or on different Racks. When using a connecting cable (CS1D-CN051) between the Units, however, the cable length is 50 cm and so mount the Units in adjacent slots.

- Set the same unit number and node address for the two Units.

Note If the same unit number and node address are not set for the Units, it will not be possible to create I/O tables.

- Set the unit number of the two Units in *PLC Settings - Duplex Settings* in the CX-Programmer (Ver. 3.0 or later).

If the unit number is 0, click the checkbox next to *Communication Unit 0* (indicated by the arrow).

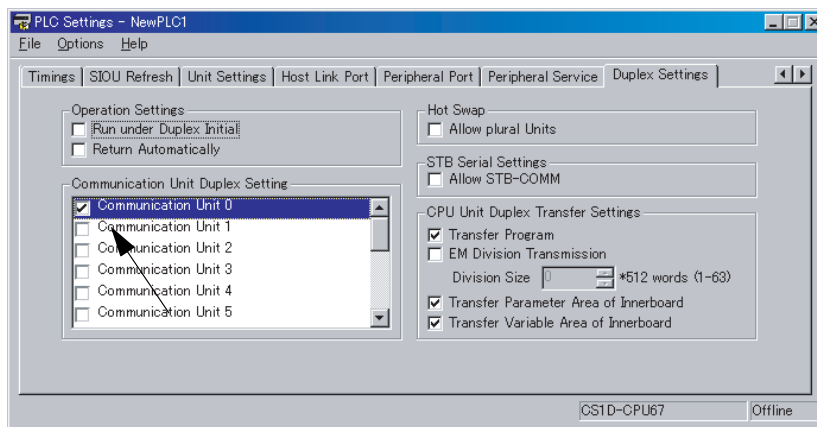

After transferring the PLC Setup settings, reset the CS1D's power supply. For details on the operation method, refer to 8-3-2 Duplex Settings in the PLC Setup.

Note (a) If the duplex settings in the PLC Setup are not performed, it will not be possible to create I/O tables.

(b) Connect the CX-Programmer to the active CPU Unit when transferring the PLC Setup settings to the CS1D. The settings cannot be transferred to the CPU Unit if the CX-Programmer is connected to the standby CPU Unit. (Only reading is possible.)

- Set the transmission path format to token-ring mode using the software switches in the CPU Unit's DM parameter area. (Set bits 8 or 9 to 1.)

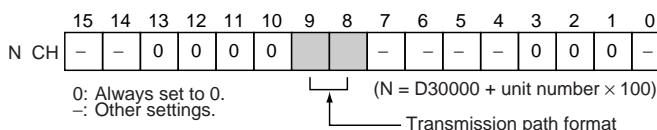

Transmission Path Format

Bit		Setting contents
9	8	
0	0	Token-ring mode
0	1	
1	0	
1	1	Token-bus mode

- Reset the CS1D's power supply. (A Unit/Rack Number Duplication Error will occur.)
- Create I/O tables and set the operating mode for each of the Duplex Controller Link Units. The Unit mounted in the slot with the lower slot number will be in active mode. (The operating mode can be changed later.)

If the I/O tables are created correctly, the status of the LED indicators for each of the Units will be as shown in the following table.

Unit	LED indicator status
Active mode	RUN indicator: Lit RING indicator: Lit (See note.)
Standby mode	RUN indicator: Flashes

For details on the operation method, refer to 8-3-3 Creating I/O Tables for Duplex Systems.

Note If I/O tables cannot be created, check the following items.

- 1) In the PLC Setup's duplex settings, make the Communications Unit duplex setting for the corresponding unit number. Also, after transferring the PLC Setup settings, reset the CS1D's power supply to enable the settings.
- 2) Set the same unit number for the two Duplex Units.
- 3) Set the same node address for the two Duplex Units.
- 4) When using duplex Communications Units, use the duplex Controller Link Units. Duplex operation is not possible with other Units.
- 5) Complete online replacement if the procedure has not been completed.
- 6) If there is an error in the CPU Unit, remove the cause of the error.
- 7) Perform wiring for the backup (24-V) power supply cable.

Note Use a backup power supply with duplex communications systems. By providing a backup power supply, the node bypass circuits in the Controller Link Unit will operate, and the influence on the network of active/standby switchover and online replacement can be reduced to a minimum.

7. Turn OFF the power supply, and perform wiring for the fiber-optic cable. When using an H-PCF cable, connect the two Duplex Controller Link Units using either a CS1D-CN051 Connecting Cable or a standard H-PCF cable.

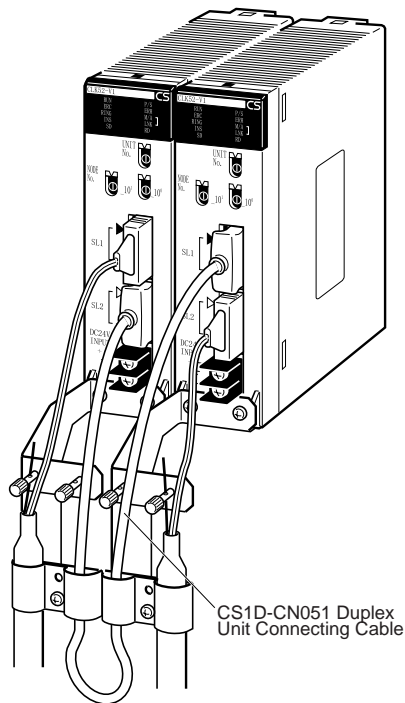

Duplex Unit Connecting Cable (H-PCF Cable)

Name: Duplex Unit Connecting Cable (H-PCF Cable)

Length: 50 cm

Model number: CS1D-CN051

Note If a GI cable is used to connect the Units, use a standard GI cable. Take note, however, of the following points.

1. Use a GI cable of length at least 50 cm.

2. Ensure that the cable does not exceed its maximum bending radius.
3. Use the following procedure to use data links.
 - a. Set the transmission path format, data link manual/automatic setting, and data link status storage format using the software switches in the DM parameters area of the CPU Unit.
 - b. Register the data link tables if using manual setting. If automatic setting is used, set the data link automatic setting parameters.
 - c. Turn ON the Data Link Start/Stop Bit (software switch in bit 0 of the DM parameters area of the CPU Unit) for the duplex node Controller Link Units (CS1D system).

Note In CS1D Systems with Controller Link Units used in duplex operation, set the duplex node as a startup node for data links (Data Link Start/Stop Bit in the CS1D System CPU Unit is turned ON). If the duplex node is not set to be a startup node for data links (Data Link Start/Stop Bit in the CS1D System CPU Unit is OFF), and the relevant node is operating as a polling node, the network's data links may stop if an ACT/STB (active/standby) switchover error occurs.

8-3-2 Duplex Settings in the PLC Setup

In the PLC Setup on the CX-Programmer, select *Options - Duplex Settings*. Click the Duplex Settings Tab and click the checkbox next to the unit number for the Duplex Communications Units.

Example: Duplex Settings for Communications Units with Unit Number 0

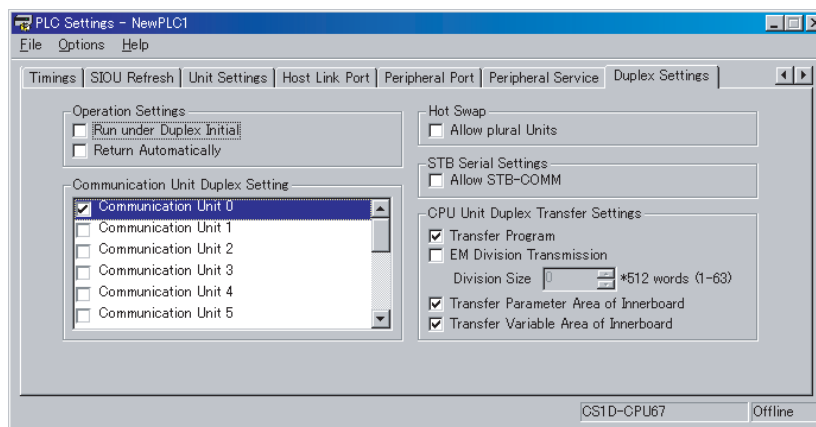

For details on settings other than duplex settings for Communications Units or the PLC Setup, refer to the *CS-series Duplex System Operation Manual (W405)*.

- Note**
1. Duplex settings for Communications Units can be performed with CX-Programmer Ver. 3.0 or later.
 2. Connect the CX-Programmer to the active CPU Unit when transferring the PLC Setup settings to the CS1D. The settings cannot be transferred to the CPU Unit if the CX-Programmer is connected to the standby CPU Unit. (Only reading is possible.)
 3. After changing PLC Setup settings, enable the changes by resetting the PLC's power supply.

8-3-3 Creating I/O Tables for Duplex Systems

Creating I/O Tables Based on Mounted Units

Display the CX-Programmer's I/O Table Window and select *Options – I/O Table Creation*. The type of Units mounted and the mounting position will be written to the CPU Unit as a registration I/O table. The Unit mounted in the slot with the lower slot number will be set to active mode and the other Unit will be set to standby mode.

When an I/O table is created, the I/O Table Window will be displayed in the way shown below. The first word in the CPU Bus Unit Area allocated to the active Unit (1500 in the example below) is displayed in brackets. (The first word allocated in the CPU Bus Unit Area depends on the unit number setting.) For the standby Unit, "STB" is displayed in brackets.

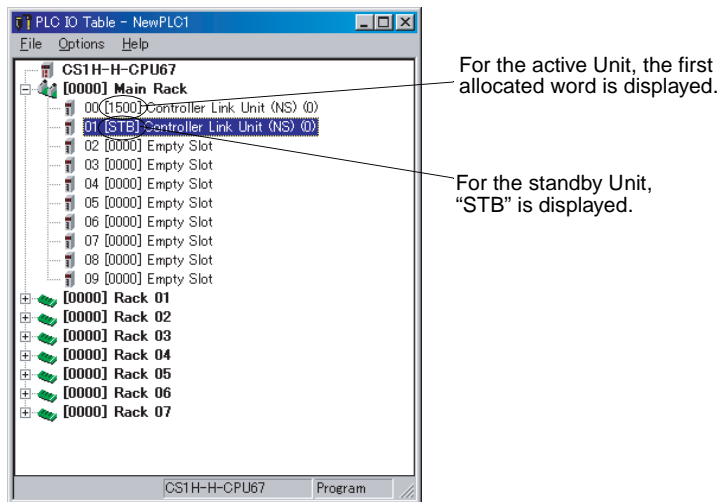

Note Once the I/O table has been created based on the mounted Units in the way shown above, the active/standby settings for the Units can be switched without changing the mounting configuration using the following procedure.

1. In the offline I/O Table Window, delete both of the relevant Units. (Right-click the Units and select *Delete* from the pop-up menu.)
2. Using the procedure described below (*Editing I/O Tables Offline*), reregister the relevant Units and register the operating modes.

**Editing I/O Tables
Offline**

I/O tables can be edited offline and then, after going online, transferred to the CPU Unit. The procedure for setting the Controller Link Unit mounted in slot 00 to active mode and setting the Controller Link Unit mounted in slot 01 to standby mode is given below as an example.

1. Open the I/O Table Window in CX-Programmer.

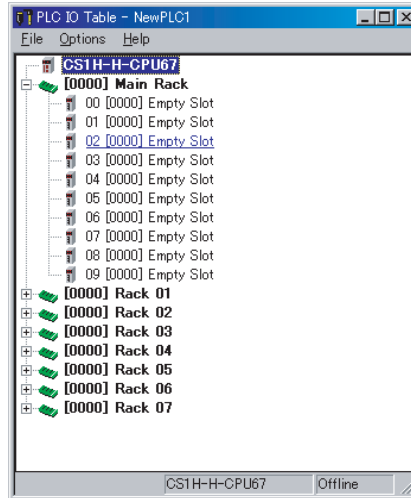

2. Right-click slot 00 and select *Controller Link Unit (NS)* from the pop-up menu.
3. The Enter CPU SIO Unit Number Dialog Box will be displayed. Select the unit number set for the Controller Link Units from the *Unit Number* drop-down list. In order to set the Unit in slot 00 to active mode, deselect (i.e., click if necessary) the checkbox next to *STB Mode (CS1D Only)*.

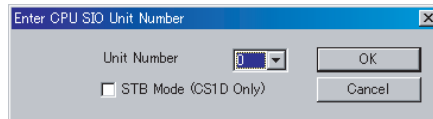

4. In the same way, right-click slot 01 and select *Controller Link Unit (NS)* from the pop-up menu to display the Enter CPU SIO Unit Number Dialog Box. In order to set the Unit in slot 01 to standby mode, select (i.e., click if necessary) the checkbox next to *STB Mode (CS1D Only)*.

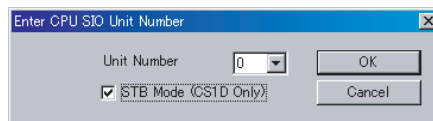

5. When the settings are completed, the I/O Table Window will be displayed in the way shown below. The first word in the CPU Bus Unit Area allocated to the active Unit (1500 in the example below) is displayed in brackets. (The first word allocated in the CPU Bus Unit Area depends on the unit number setting.) For the standby Unit, "STB" is displayed in brackets.

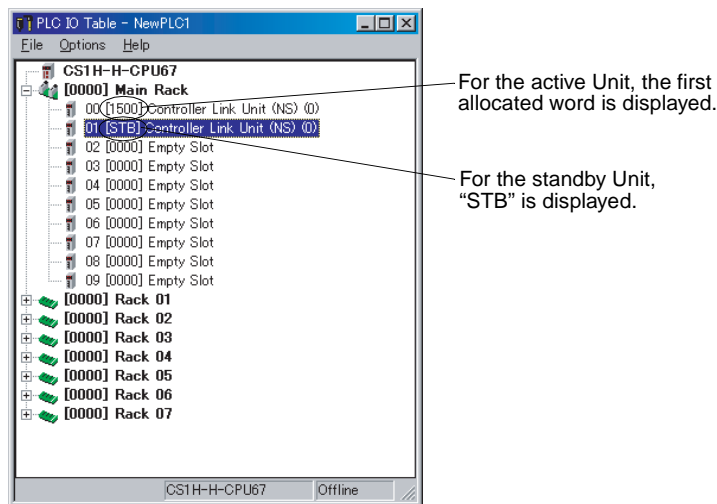

- Note**
1. Duplex settings for Communications Units (i.e., PLC Setup settings and I/O table creation/editing) can be performed with CX-Programmer Ver. 3.0 or later.
 2. When settings are made for a standby Unit, the following message is displayed. If the duplex settings for Communications Units in the PLC Setup are complete, this message can be ignored.

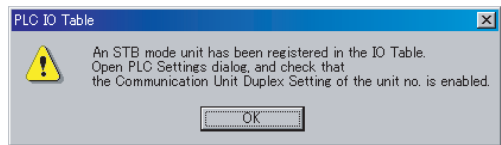

8-4 Precautions for Duplex Systems

- If an error occurs in an active Controller Link Unit and there is an active/standby switchover, or if an active Controller Link Unit is replaced online, because the relevant node will temporarily leave and then re-enter the network, communications operations (both message communications and data links) will be temporarily stopped. At this time, the Data Link Participation Flag for the relevant node will turn OFF, and the Communications Error Flag will turn ON. After the switchover, communications will resume and the status will return to normal (the Data Link Participation Flag turns ON and the Communications Error Flag turns OFF). For this reason, perform the following processing in systems where there are duplex nodes in the network.
 - When using message communications, set the number of retries for the SEND, RECV, and CMND instructions (i.e., set the number of retries in the control data to a value other than 0), and be sure to perform resend processing for instructions.

- When using data links, while communications operations are stopped, data will not be sent or received for the relevant node. (Data sent or received, however, via data link immediately before communications stopped will be saved.) Therefore, if necessary for the application, include processing to control whether data received via data link after communications resumes (i.e., when the Data Link Participation Flag changes from OFF to ON and the Communications Error Flag changes from ON to OFF) is enabled or not. (Include processing in the ladder programs for the CPU Units at the relevant node and the data link destination node).

A theoretical value for the time required for communications to resume can be obtained using an equation. (Refer to 8-5 *Switching Time for Duplex Units.*)

- Units can only be used in duplex operation if duplex-compatible Controller Link Units are mounted to the CS1D PLC. Other Units cannot be used for duplex operations.
- Units can be used in duplex operation in either CS1D Duplex Systems or CS1D Simplex Systems.
- When using Units in duplex operation, use Controller Link in token-ring mode. Token-ring mode's transmission path duplication and the CS1D System's duplex function for Communications Units allow the creation of a highly reliable network. If used in token-bus mode, the network will be temporarily split into two networks when Controller Link Units are replaced online because the transmission path is not duplicated.
- Basically, the maximum number of CS-series CPU Bus Units that can be mounted to a single CS1D PLC (including Expansion Racks) is 16. This is because unit numbers are restricted to the range 0 to 15. For this reason, standby Controller Link Units that have the same unit number as an active Controller Link Unit are not included in this figure. (For example, if there are 3 pairs of Duplex Units, the maximum number of mountable Units is 19.)
- CX-Programmer Ver. 3.0 or later is required to make settings for Duplex Units.
- Although standby Controller Link Units do not participate in the network as nodes, they are physically connected to the network and so they are included in the figure for the maximum number of connectable Units. For this reason, up to a total of 62 active and standby Controller Link Units can be connected. Therefore, if all the nodes are used in the CS1D System, with all the Controller Link Units used in duplex operation, the maximum number of nodes is 31 (62 – Number of standby Controller Link Units).

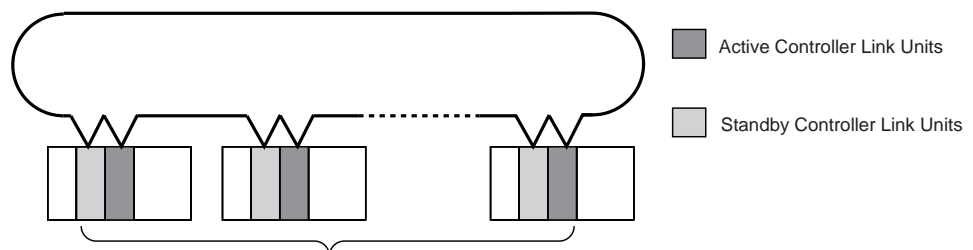

In 1 network, a total of up to 62 active and standby Controller Link Units can be connected (31 nodes).

- It is also possible to use only some of the Units in the Controller Link Network in duplex operation. In this case, up to a total of 62 active and standby Controller Link Units and Controller Link Units that are not used in duplex operation can be connected. The Units that are not used in duplex operation can include both existing Units (CS1W-CLK12, CS1W-CLK52, CVM1-CLK12, or CVM1-CLK52) and duplex-compatible Units.

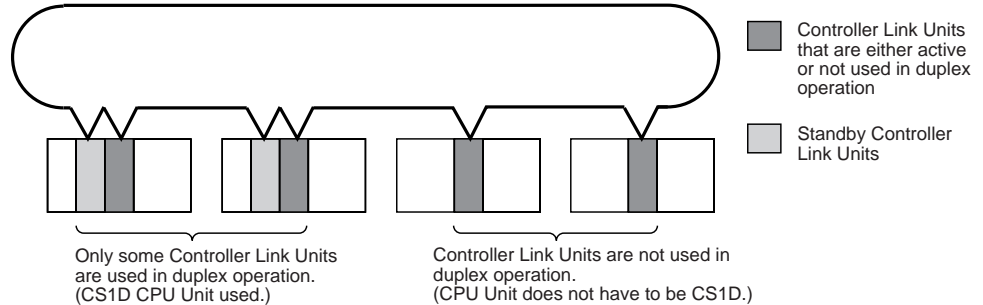

- As long as they are mounted on the same PLC, two Controller Link Units used in duplex operation can be mounted on different Racks or in non-adjacent slots.
- When using Units in duplex operation, construct the Controller Link Network so that the Controller Link Units used in duplex operation are adjacent to each other in the network. (As long as they are within the maximum distance between nodes for Controller Link Networks, there is no restriction on the physical distance.) If they are not adjacent to each other, because the node position will change when there is an active/standby switchover, it may not be possible to identify the location of disconnections.
- Communications data passes through Controller Link Units in standby mode in both directions without any processing. If the backup power supply for a Controller Link Unit in standby mode is interrupted, however, a disconnection may be detected at the position of the Unit.
- In CS1D Systems with Controller Link Units used in duplex operation, set the duplex node as a startup node for data links (Data Link Start/Stop Bit in the CS1D System CPU Unit is turned ON). If the duplex node is not set to be a startup node for data links (Data Link Start/Stop Bit in the CS1D System CPU Unit is OFF), and the relevant node is operating as a polling node, the network's data links may stop if an ACT/STB (active/standby) switchover error occurs.

8-5 Switching Time for Duplex Units

If an error occurs in an active Controller Link Unit and there is an active/standby switchover, or if an active Controller Link Unit is replaced online, because the relevant node will temporarily leave and then re-enter the network, communications operations (both message communications and data links) will be temporarily stopped.

The time required for communications to resume can be obtained using the following equation.

Equation for Calculating the Communications Recovery Time for Duplex Units

Maximum communications recovery time = 1,000 ms + Network participation waiting time (See note.) + PLC cycle time × 2

Minimum communications recovery time = 1,000 ms

Note Network Participation Waiting Time:

Maximum network participation waiting time = Communications cycle time × (Maximum node address in the network parameters – 1) ÷ Number of polled nodes in the network parameters

Calculation Example

As an example, the calculation for the following conditions is given below.

Communications cycle time: 20 ms (Number of nodes: 10; Number of data link words: 1,000)

Network parameters: Default settings (Maximum node address: 62; Number of polled nodes: 4; Number of event-frames: 35)

PLC cycle time: 15 ms

The communications recovery time is given by the following calculation:

Maximum value = 1,000 ms + 20 ms × (62 – 1) ÷ 4 + 15 ms × 2 = 1,335 ms

Minimum value = 1,000 ms

Note The maximum network participation waiting time can be reduced by changing the network parameters in the way described below. Making settings 1 and 2 below will reduce the network participation waiting time to a maximum of 1 communications cycle. Change the network parameters using CX-Net in CX-Programmer.

1. Set the maximum node address setting in the network parameters to the same value as the maximum address of the actual nodes in the network.
2. Set the number of polled nodes setting in the network parameters to the same value as the maximum node address setting.

Note Controller Link does not perform polling operations (e.g., checking network participation, establishing participation) for nodes with addresses larger than the maximum node address setting. Also, with each cycle, polling operations are performed for the number of nodes set in the number of polled nodes setting. Therefore, making settings 1 and 2 above will reduce the network participation waiting time to a maximum of 1 communications cycle.

8-6 Auxiliary Area Bits/Words and PLC Setup Settings Related to Duplex Communications Units

8-6-1 Auxiliary Area

Word(s)	Bit(s)	Name		Function
A027	00 to 15	Duplex Communications Unit Operating Flags		Turn ON when the Communications Unit with the corresponding unit number is in duplex operation. ON: Duplex communications operation OFF: Not in duplex communications operation
A042 to A049	00 to 15	Duplex Communications Switch Cause Flags (See note.)		When an error occurs in the active Communications Unit and operation is switched to the standby Communications Unit, an error code will be stored to show the cause of the error in the active Communications Unit. (See note.) The code is set to 00 Hex if online replacement is performed for the faulty Unit. The corresponding bit in A436 will also turn ON.
A261	10	Error information for I/O table creation	Online Replacement Flag	Turns ON when a Basic I/O Unit, Special I/O Unit, or CPU Bus Unit is being replaced online on the CPU Rack, an Expansion Rack, or a Long-distance Expansion Rack. If an attempt is made to generate the I/O tables while this flag is ON, an I/O table generation error will occur and the I/O tables will not be created. ON: During online replacement OFF: I/O table creation completed normally.
	11		Duplex Communications Unit Missing or Non-Duplex Communications Unit Mounted Flag	Turns ON when a Duplex Communications Unit is not mounted for a unit number specified for Duplex Communications Units in the PLC Setup or the mounted Unit does not support duplex operation. If an attempt is made to generate the I/O tables while this flag is ON, an I/O table generation error will occur and the I/O tables will not be created. ON: A Duplex Communications Unit is missing or the mounted Unit does not support duplex operation. OFF: I/O table creation completed normally. The corresponding bit in A434 will also turn ON.
	12		Duplex Communications Unit Verification Error Flag	Turns ON when the unit numbers or node addresses of two Units specified as a pair of Duplex Communications Units in the PLC Setup do not agree. If an attempt is made to generate the I/O tables while this flag is ON, an I/O table generation error will occur and the I/O tables will not be created. ON: Verification error OFF: I/O table creation completed normally. The corresponding bit in A435 will also turn ON.

Word(s)	Bit(s)	Name	Function
A316	03	Duplex Communications Error Flag	<p>Turns ON when there is an error in a Duplex Communications Unit (either active or standby). This flag can be used to check whether or not there are errors in any Duplex Communications Units.</p> <p>ON: There is an error in a Duplex Communications Unit.</p> <p>OFF: All Duplex Communications Units are operating normally.</p> <p>This flag will turn ON if any of the flags below turn ON.</p> <p>A43600 to A43615: Duplex Communications Switched Flags</p> <p>A43700 to A43715: Duplex Communications Standby Unit Error Flags</p>
A434	00 to 15	Duplex Communications Error Recognition Flags	<p>Turns ON when a Duplex Communications Unit is not mounted for a unit number specified for Duplex Communications Units in the PLC Setup or the mounted Unit does not support duplex operation.</p> <p>Bits 00 to 15 correspond to unit numbers 0 to F.</p> <p>ON: Duplex communications recognition error</p> <p>OFF: No duplex communications recognition error</p>
A435	00 to 15	Duplex Communications Setting Error Flags	<p>Turns ON when the unit numbers or node addresses of two Units specified as a pair of Duplex Communications Units in the PLC Setup do not agree.</p> <p>Bits 00 to 15 correspond to unit numbers 0 to F.</p> <p>ON: Duplex communications verification error</p> <p>OFF: No duplex communications verification error</p>
A436	00 to 15	Duplex Communications Switched Flags (non-fatal communications error)	<p>Turns ON when an error occurs in the active Communications Unit and operation is switched to the standby Communications Unit. Communications will be continued by the standby Communications Unit.</p> <p>Bits 00 to 15 correspond to unit numbers 0 to F.</p> <p>ON: Operation switched</p> <p>OFF: Operation not switched</p> <p>This flag is turned OFF when online replacement is performed for the faulty Communications Unit. A code indicating the cause of the switch is stored in A042 to A049.</p>
A437	00 to 15	Duplex Communications Standby Unit Error Flags (non-fatal communications error)	<p>Turns ON when an error occurs in the standby Communications Unit (from self-diagnosis). Communications will be continued by the active Communications Unit.</p> <p>Bits 00 to 15 correspond to unit numbers 0 to F.</p> <p>ON: Standby Communications Unit error</p> <p>OFF: Standby Communications Unit normal</p> <p>This flag is turned OFF when online replacement is performed for the faulty Communications Unit.</p>

Note Duplex Communications Switch Cause Flags (A042 to A049)

	15	8 7	0	
A042	Unit number 1	Unit number 0		The following error codes are written to the corresponding area for each unit number. 01 Hex: EEPROM error 02 Hex: Error in the communications controller's transmitter 03 Hex: Hardware error in the communications controller 80 Hex: Watchdog timer error
A043	Unit number 3	Unit number 2		
A044	Unit number 5	Unit number 4		
A045	Unit number 7	Unit number 6		
A046	Unit number 9	Unit number 8		
A047	Unit number 11	Unit number 10		
A048	Unit number 13	Unit number 12		
A049	Unit number 15	Unit number 14		

8-6-2 PLC Setup

The Duplex Unit settings (the checkboxes for unit numbers 0 to 15 under *Communication Unit Duplex Setting* in the CX-Programmer) can be set with the addresses given below.

Address in Programming Console		Settings	Function	New setting's effectiveness
Word	Bits			
121	0 to 15	0: Disable duplex settings for Communications Units 1: Enable duplex settings for Communications Units Default: 0	These settings (individual bits) enable or disable duplex settings for individual Communications Units. Bits 00 to 15 correspond to unit numbers 0 to 15. Active/standby can be specified by selecting the slot with the standby Unit using the I/O table editing operations from the CX-Programmer.	At power-ON

Note Duplex settings for Communications Units in the PLC Setup can be performed with CX-Programmer Ver. 3.0 or later.

SECTION 9

Communications Timing

This section explains details on Controller Link Network communications. Refer to this section for network communications that require accurate communications timing.

9-1	Communications Mechanism	218
9-1-1	Data Transmissions over the Network	218
9-1-2	Setting the Polling and Polled Nodes	219
9-1-3	Network Parameters	220
9-1-4	Specifying Network Parameters	220
9-2	Communications Cycle Time	221
9-2-1	Active Data Links	221
9-2-2	Inactive Data Links	222
9-2-3	Maximum Delay for Disconnections in Token-ring Mode	223
9-3	Data Link I/O Response Time	224
9-3-1	Data Exchange Timing	224
9-3-2	Data Processing Time	225
9-3-3	Calculation Example	226
9-4	Message Delay Times	230
9-4-1	CS-series, CVM1, and CV-series PLCs	230

9-1 Communications Mechanism

9-1-1 Data Transmissions over the Network

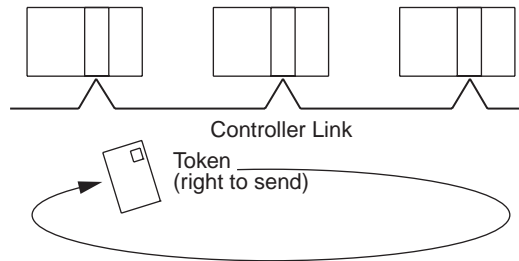

In a Controller Link Network, token passing is used to control network access. The right to send, called a “token,” circulates around the network. A node that receives the token is allowed to send data. If the node has data to send, it will attach the data to the token and send them together. If the node has no data to send, it will pass the token to the next node.

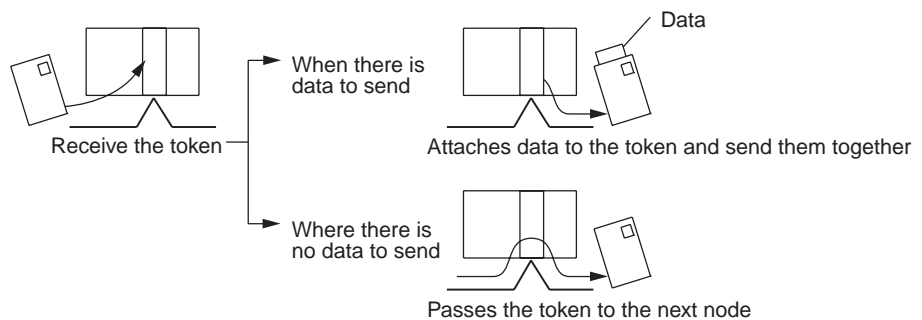

A token can be thought of as a circulating envelope. This envelope is circulated through the network and the person who receives the envelope will put a destination and a memo into the envelope to send his or her message to somebody else. This method is called “token passing.” The Optical Bus Controller Link Network is a bus network that uses token passing.

The Optical Ring Controller Link Network supports the token-ring mode, in which the transmission path can be duplicated by wiring the communication cable in a loop. (When wired in bus format, token-bus mode is used.)

The overall network communications procedure is explained below.

1,2,3...

1. The Unit at the node that manages the network, called the “polling node,” transfers the token. The token is circulated through the network in ascending order of node addresses. One cycle in which the token is circulated among all nodes on the network is called a “token circulation cycle.”
2. After one token circulation cycle is complete, the polling node checks the network connection status. One cycle in which the connection status of all nodes on the network is checked is called a “polling cycle.”
3. After one polling cycle is complete, the polling node transfers the token again.

The procedure is then repeated. In a Controller Link Network, the total time required for a token circulation cycle and a polling cycle is called the “communications cycle time.” Communications processing is executed by repeating the communications cycle.

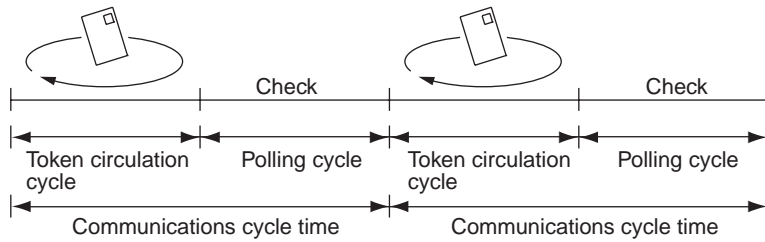

Polling Node

Each Controller Link Network always has a Unit that controls communications within the network. This Unit is called the “polling node.” Normally, the node that has the smallest node address in the network is the polling node (see note). All Units at nodes other than the polling node are called “polled nodes” (or polled units). The polling node controls the token, checks the network, and performs other relevant tasks. Should the polling node break down, the node with the next smallest node address is automatically selected as the polling node to prevent the entire network from shutting down.

Note The node with the smallest node address is not always the polling node, depending on the Unit start-up sequence, models, settings, and Unit status.

With an Optical Bus Controller Link Unit or Board, when the polling node breaks down the next polling node is temporarily disconnected from the network, reconstructs the network, and then reconnects to the network. Polled nodes remain connected to the network.

With an Optical Ring Controller Link Unit, when the polling node is shifted, the new polling node is not disconnected from the network.

When Controller Link Units are used in duplex operation, if there is an active/standby switchover resulting from an error in a Unit, because the node will temporarily leave the network before joining it again, the polling node will be shifted.

9-1-2 Setting the Polling and Polled Nodes

Use the Programming Device for the PLC to set Units as polling node or polled node in the DM parameter area.

CS-series Controller Link Units

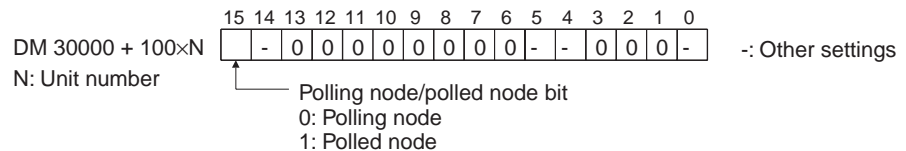

CVM1 and CV-series Controller Link Units

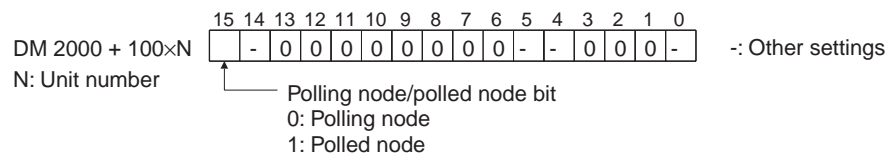

If the node is always to be connected as a polled node when the power is turned on, set it as a polled node. If the node can become a polling node when the power is turned on, set it as a polling node. One of the nodes set as a polling node will serve as the actual polling node. Except for maintenance after Unit replacement (see 10-8 Handling Precautions), set the Units all nodes as polling nodes (set the polling node/polled node bit to “0”).

9-1-3 Network Parameters

Network parameters are also used to control network operations. Network parameters are read from the polling node and distributed to all other nodes when the Controller Link Network is started. In this way, all nodes on the network always have the same network parameter settings. If nodes are connected to the network halfway during network operation, the network parameter settings will also be distributed to these nodes when they are connected. The following three network parameters can be specified.

Maximum Node Address

This parameter specifies the maximum node address of nodes to be checked by the polling node. The default is 62 (or 32 for Optical Bus Networks). Reducing the setting of this parameter reduces the number of nodes checked by the polling node and can thus avoid unnecessary check operations. However, if the network contains nodes with node addresses greater than the setting of the parameter, these nodes will not be connected to the network.

No. of Polled Nodes Per Communications Cycle

This parameter specifies the number of nodes to be checked (polled) by the polling node during each polling cycle. The default is 4. Setting this parameter to a high value increases the communications cycle time, but reduces the time required to recognize that nodes have been removed from or added to the network. Reducing the setting of this parameter shortens the communications cycle time but delays a network response when a node is disconnected from or connected to the network.

No. of Event-frames per Communications Cycle

This parameter specifies the maximum number of event frames (communications other than data links, such as message service transmissions) that can be transferred during a communications cycle. Specify a value in units of 128 bytes. The default is 35 (128 × 35 = 4,480 bytes).

Increasing the setting of this parameter increases the communications cycle time but allows for more event communications such as the message service. Too small a parameter value restricts event communications, resulting in an error. See 9-2 *Communications Cycle Time* (on page 221) for the effects of network parameters on communication cycle times.

9-1-4 Specifying Network Parameters

The network parameters can be specified from CX-Net in CX-Programmer or the Controller Link Support Software. This section describes only the allowable setting range for each network parameter. Refer to the *Controller Link Support Software Operation Manual (W308)* for setting procedures.

The following table shows the setting range and default for network parameters.

Network parameter	Setting range	Default value
Maximum node address	2 to 62	62 (See note 1.)
Number of polled nodes	1 to 31	4
Maximum number of event-frames	6 to 238	35

The network parameters become valid immediately after being set.

Note

1. The default value is 32 for Optical Bus Networks.
2. The network parameters set at the polling node will be enabled. Therefore, if there are multiple polling nodes, ensure that they all have the same settings. If there are different settings, network operation will depend on the polling node. Once the network has been constructed, however, the same network parameters will be set for all nodes.
3. Always stop the data link before changing network parameters.

4. Specify a value for the maximum node address that is equal to or greater than the maximum node address in the Controller Link Network.
5. For the CVM1 and CV-series PLCs, always set the System Protect Key Switch on the CPU Unit to NORMAL. Otherwise, the network parameter settings will not be stored normally.

9-2 Communications Cycle Time

This section describes how to calculate the communications cycle time.

9-2-1 Active Data Links

The following equations are used to calculate the communications cycle time when data links are operating.

Token-ring Mode

$$9.1 \times A + 1,740 \times B + 960 \times C + 1,100 \times D + 4 \times E + 2 \times F + 4,800 \text{ (}\mu\text{s)}$$

Token-bus Mode

$$9.1 \times A + 1,300 \times B + 290 \times C + 320 \times D + 4 \times E + 2 \times F + 2,290 \text{ (}\mu\text{s)}$$

- Note**
- A: Total number of data link words within the network (total number of words in send areas of all nodes)
 - B: Number of polled nodes per comm cycle (value specified in the network parameters)
 - C: Number of nodes connected to the network
 - D: Number of nodes that send messages during the communications cycle
 - E: Total number of bytes in messages transmitted during the communications cycle
 - F: Optical Fiber Cable transmission delay time
 - H-PCF cable: $F = 7 \times L \text{ }\mu\text{s}$ (L is the cable length in km.)
 - GI cable: $F = 5 \times L \text{ }\mu\text{s}$ (L is the cable length in km.)

The number of bytes in each message differs according to the instruction being issued, as shown in the following table.

Instruction	When sent	When received
SEND	Number of words to be sent $\times 2 + 18$	14
RECV	18	Number of words to be received $\times 2 + 14$
CMND	Number of bytes in command data + 10	Number of bytes in response data + 10

Calculation Example

Communications conditions are as follows:

- Transmission distance (with H-PCF cable): 8 km
- Transmission speed: 2 Mbps (fixed)
- Network parameters: Defaults
- Max node address: 62
- Polled nodes per comm cycle: 4
- Event-frames per comm cycle: 35
- Network configuration: 8 nodes
- Total number of data link words: 8,000 words
- Nodes that send messages: 2 nodes
- Bytes in all messages sent: $2,012 \times 2$ bytes

In this example, A to E in the equation have the following values.

- A: 8,000
- B: 4
- C: 8
- D: 2
- E: 4,024
- F: 7×8

The communications cycle time in token-ring mode is thus as follows:

$$9.1 \times 8,000 + 1,740 \times 4 + 960 \times 8 + 1,100 \times 2 + 4 \times 4,024 + 2 \times 7 \times 8 + 4,800 = 110,648 \text{ (\mu s)} \cong 111 \text{ (ms)}$$

And the communications cycle time in token-bus mode is as follows:

$$9.1 \times 8,000 + 1,300 \times 4 + 290 \times 8 + 320 \times 2 + 4 \times 4,024 + 2 \times 7 \times 8 + 2,290 = 99,458 \text{ (\mu s)} \cong 100 \text{ (ms)}$$

9-2-2 Inactive Data Links

The following equations are used to calculate a communications cycle time when the data link is inactive.

Token-ring Mode

$$1,740 \times B + 450 \times C + 1,100 \times D + 4 \times E + 2 \times F + 3,000 \text{ (\mu s)}$$

Token-bus Mode

$$1,300 \times B + 110 \times C + 320 \times D + 4 \times E + 2 \times F + 1,800 \text{ (\mu s)}$$

- Note**
- B: Number of polled nodes per communications cycle (value specified in the network parameter)
 - C: Number of nodes connected to network
 - D: Number of nodes that send messages during the communications cycle
 - E: Total number of bytes in messages transmitted during the communications cycle
 - F: Optical Fiber Cable transmission delay time
 - H-PCF cable: $F = 7 \times L \text{ \mu s}$ (L is the cable length in km.)
 - GI cable: $F = 5 \times L \text{ \mu s}$ (L is the cable length in km.)

The number of bytes in each message differs according to the instruction being issued, as shown in the following table.

Instruction	When sent	When received
SEND	Number of words to be sent \times $2 + 18$	14
RECV	18	Number of words to be received $\times 2 + 14$
CMND	Number of bytes in command data + 10	Number of bytes in response data + 10

Calculation Example

Communications conditions are as follows:

- Transmission distance (with H-PCF cable): 8 km
- Transmission speed: 2 Mbps
- Network parameters: Defaults
- Max node address: 62
- Polled nodes per comm cycle: 4
- Event-frames per comm cycle: 35
- Network configuration: 8 nodes
- Nodes that send messages: 2 nodes
- Bytes in all messages sent: $2,012 \times 2$ bytes

In this example, A to F in the equation have the following values.

- B: 4
- C: 8
- D: 2
- E: 4,024
- F: 7 × 8

The communications cycle time in token-ring mode is thus as follows:

$$1,740 \times 4 + 450 \times 8 + 1,100 \times 2 + 4 \times 4,024 + 2 \times 7 \times 8 + 3,000 = 31,968 \text{ (}\mu\text{s)}$$

$$\cong 32 \text{ (ms)}$$

And the communications cycle time in token-bus mode is thus as follows:

$$1,300 \times 4 + 110 \times 8 + 320 \times 2 + 4 \times 4,024 + 2 \times 7 \times 8 + 1,800 = 24,728 \text{ (}\mu\text{s)}$$

$$\cong 25 \text{ (ms)}$$

9-2-3 Maximum Delay for Disconnections in Token-ring Mode

Although the redundant transmission paths in token-ring mode ensure that communications will continue even if there is one disconnection, the communications cycle time will be affected. The data that is received first from the two reception interfaces (SL1 and SL2) will be used. A disconnection, however, may cause the data that should arrive first to be lost, causing a delay before the data is received on the other interface. The delay will thus be the time difference between receiving the same data on the two reception interfaces (assuming it was received). This delay will occur at each node as the right to send is passed, and the maximum delay in the overall cycle time will be the sum of the delay at each node.

On a Controller Link Network, the right to send is passed at the following times.

- When the token is passed.
- When the nodes being checked from the polling node for network participation change (depends on the number polled nodes per cycle set in the network parameters)
- When different nodes send messages requiring responses

The delay in the cycle time will depend on where the disconnection occurs, but the time to pass the right to send can be reduced by connecting nodes in order of node address.

Maximum Cycle Time Delay for Networks Connected in Order of Node Addresses

The maximum delay in the communications cycle time can be calculated as follows when the nodes are connected in order of node address.

$$(A \times 4 + B \times 2 + 1) \times (3 \times C + D) \text{ (}\mu\text{s)}$$

Where,

- A: Number of polled nodes per cycle
(value specified in the network parameter)
- B: Number of nodes that send messages during the cycle
- C: Number of nodes participating in the network
- D: Optical Fiber Cable transmission delay time
 H-PCF cable: $F = 7 \times L \text{ }\mu\text{s}$ (L is the cable length in km.)
 GI cable: $F = 5 \times L \text{ }\mu\text{s}$ (L is the cable length in km.)

Calculation Example

Communications conditions in this example are as follows:

Transmission distance (with H-PCF cable):	8 km
Transmission speed:	2 Mbps
Network parameters:	Defaults
Max node address:	62
Polled nodes per comm cycle:	4
Event-frames per comm cycle:	35

Network configuration:	8 nodes
Nodes that send messages:	2 nodes
Bytes in all messages sent:	2,012 × 2 bytes

In this example, A to D in the equation have the following values.

A: 4; B: 2; C: 8; D: 7 × 8

The maximum communications cycle delay in token-ring mode would be as follows:

$$(4 \times 4 + 2 \times 2 + 1) \times (3 \times 8 + 7 \times 8) = 1,680 \text{ (}\mu\text{s)}$$

$$\cong 1.7 \text{ (ms)}$$

The rate of change in the communications cycle time when data links are active would be as follows (refer to 9-2-1 Active Data Links):

$$(111 + 1.7)/111 \times 100 \cong 101.5 \text{ (%)}$$

The rate of change in the communications cycle time when data links are inactive would be as follows (refer to 9-2-2 Inactive Data Links):

$$(32 + 1.7)/32 \times 100 \cong 105.3 \text{ (%)}$$

9-3 Data Link I/O Response Time

When accurate communications timing is required, you need to understand data exchange timing and the time required for data transmission and reception via data links. Use the information described in this section as reference information for system construction.

9-3-1 Data Exchange Timing

This section describes data exchange timing for data links between the Controller Link Unit and the PLC's CPU Unit. Data exchange is executed as interrupt processing during CPU Bus Unit or Programming Device/Host Link servicing performed by the CPU Unit. This interrupt processing is executed each time data exchange between the local node and each node connected via a data link is completed.

Data exchange timing differs depending on the CPU Unit model and the CPU Unit the Execute Process (asynchronous or synchronous) specified in PLC Setup, as described below.

CVM1 and CV-series PLCs Under Asynchronous Operation

When a CVM1 or CV-series CPU Unit is operating in asynchronous mode, data exchange with the Controller Link Unit is executed as interrupt processing during peripheral processing, regardless of the cycle time of PLC instruction execution. Data exchange timing is as follows:

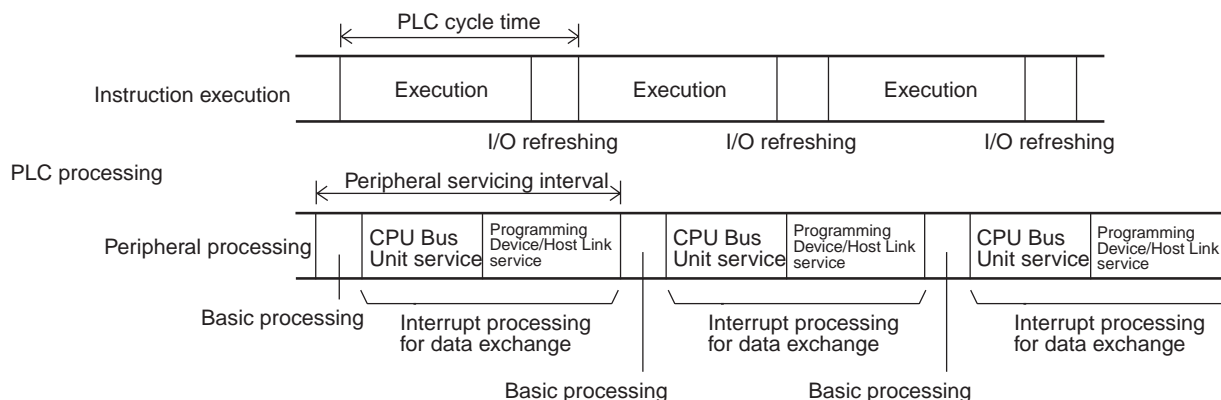

More than one data exchange can be executed during a PLC cycle, depending on the data exchange timing. If interrupt processing for data exchange is executed, the peripheral servicing interval will be lengthened by the time required for the interrupt processing (see 9-3-2 Data Processing Time on page 225).

CS-series PLCs, CVM1 and CV-series PLCs in Synchronous Mode

When a CS-series, CVM1, or CV-series PLC is operating in synchronous mode, data exchange with the Controller Link Unit is executed during peripheral processing for the PLC cycle. Data exchange timing is as follows:

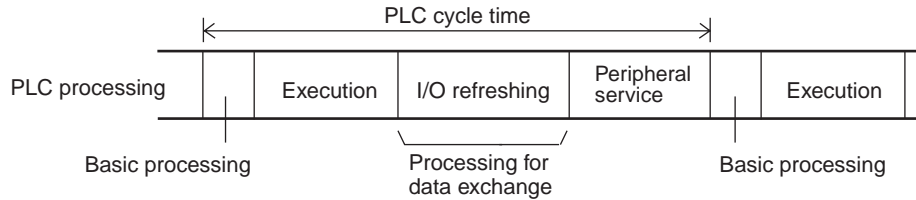

If processing for data exchange is executed, the PLC cycle time will be lengthened by the time required for processing (see 9-3-2 Data Processing Time below).

9-3-2 Data Processing Time

The time required to process data exchange (data processing time) can be roughly estimated as shown in the following table.

CPU Unit	Equation estimating data processing time
CS1-H-series CPU Unit	$0.1 \text{ ms} + \text{Number of transfer words} \times 0.7 \mu\text{s}$
CS1-series CPU Unit	$1.5 \text{ ms} + \text{Number of transfer words} \times 1 \mu\text{s}$
CVM1-series CPU Unit	$1.7 \text{ ms} + \text{Number of transfer words} \times 1 \mu\text{s}$

The number of words processed in a single data exchange is shown in the following table for each series of PLC. If the number of data link words exceeds the value shown in the table, data exchange will be executed as several separate processes.

PLCs	Words per data exchange
CS-series PLCs	Approx. 7,800 words
CVM1 and CV-series PLCs	Approx. 3,700 words

- Note**
1. Use the above equations only if only one Controller Link Unit is mounted on the PLC. If other CPU Bus Units are mounted on the PLC, obtain the refresh times for each CPU Bus Unit and add to the above equations.
 2. The execution of some items takes precedence over data link area refreshing. For example, data link area refreshing will not take place during execution of the SEND(192), RECV(193), or FAL(006) instruction.

9-3-3 Calculation Example

The data links of the Controller Link Unit require a slight time delay from the time the data link area of one node is changed until this change is reflected in the data link area at another node. This time delay is called the data link I/O response time. The following is a calculation example of the maximum and minimum I/O response times for the system configuration shown below.

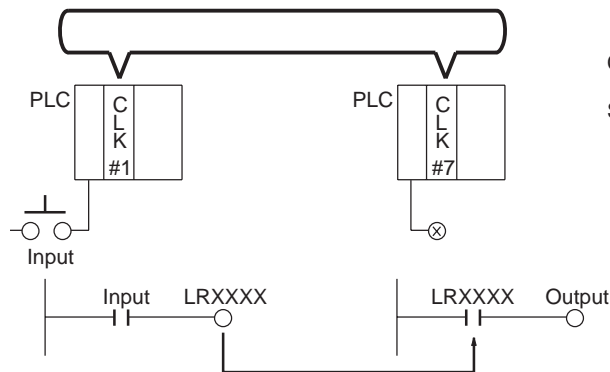

CLK: Controller Link Unit

System configuration

H-PCF cable used	Token-ring mode
Connection method:	8 km
Transmission distance:	62
Maximum node address:	8 nodes
Number of polled nodes per comm cycle:	4
Number of event-frames per comm cycle:	35
Nodes in network:	8 nodes
Nodes in data links:	8 nodes
Words sent in area 1:	8 words per node
Words in area 2:	16 words per node

No messages communications are performed.

A single Controller Link Unit is mounted to each CPU Rack.

The data link I/O response time depends on the communications cycle time, input ON delay, output ON delay, and the cycle times of the PLCs involved. The values are detailed below.

Communications Cycle Time

Communications cycle time =
 $9.1 \times (8 + 16) \times 8 + 1,740 \times 4 + 960 \times 8 + 2 \times 7 \times 8 + 4,800 = 21,299 \mu\text{s} \cong 22 \text{ ms}$

Input ON Delay

The input ON delay is the time it takes for an input device to turn ON an input to the PLC after receiving an input signal. In this system the input ON delay is 1.5 ms max.

Output ON Delay

The output ON delay is the time it takes for an output device to turn ON an output signal after receiving an output from the PLC. In this system the output ON delay is 15 ms max.

Cycle Times

The cycle time of the PLC at node #1 is 25 ms.
 The cycle time of the PLC at node #7 is 10 ms.

CVM1, CV-series, CS-series PLCs Under Synchronous Operation

Maximum Data Link I/O Response Time

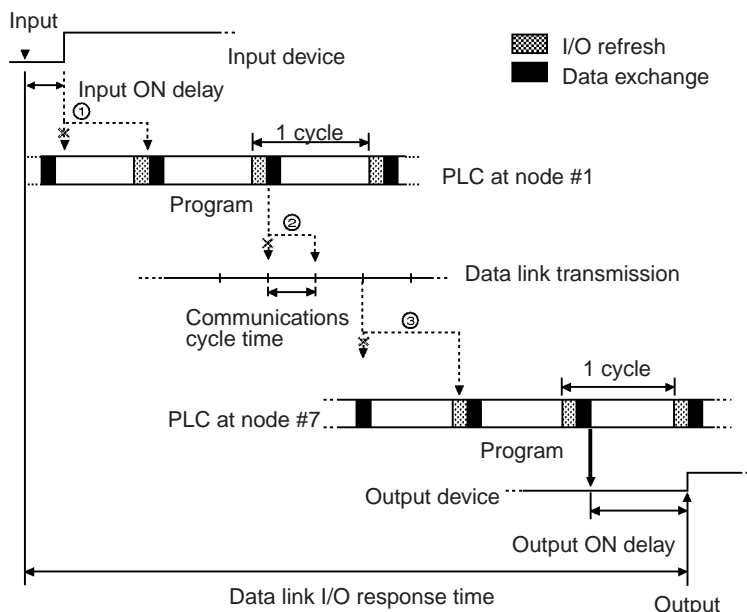

There are three points shown in the diagram above where processing is delayed, increasing the data link I/O response time.

- 1,2,3...
1. The input arrives in the PLC just after I/O refreshing, causing a delay of up to one cycle before the input is read into the PLC.
 2. Data exchange occurs just after the PLC at node #1 passes the token that makes it the polling node, causing a delay of up to one communications cycle time before the data is transferred in data link processing.
 3. At node #7, data from the previous data exchange is still being transferred, causing a delay of up to one cycle before the input is read into the PLC. (If the cycle time at node #7 is longer than the communications cycle time, the processing will be delayed for two cycles.) Also, if the total number of data link words exceeds the maximum number for a single exchange, the data exchange will be divided up and there may be a delay of one to two additional cycles.

The maximum number of words that can be exchanged in a single data exchange is approx. 7,800 words for CS-series PLCs and approx. 3,700 words for CVM1 and CV-series PLCs.

The equation for the maximum data link I/O response time is as follows:

Input ON response time	1.5 ms
Cycle time of PLC at node #1 × 2	25 ms × 2
Communications cycle time × 2	22 ms × 2
PLC cycle time at node #7 × 2	10 ms × 2 (See note.)
Output ON response time	15 ms
Total (data link I/O response time)	130.5 ms

Note The PLC cycle time when data link words exceed 12,000 using a CS-series Controller Link Unit with unit version 1.2 or later is calculated as follows.

- 12,000 to 15,600 (approx.) words: × 3
- 15,600 (approx.) to 20,000 words: × 4

If there is a node with more than 3,850 send words, however, the factors become $\times 5$ and $\times 6$.

Noise may increase I/O delays.

Minimum Data Link I/O Response Time

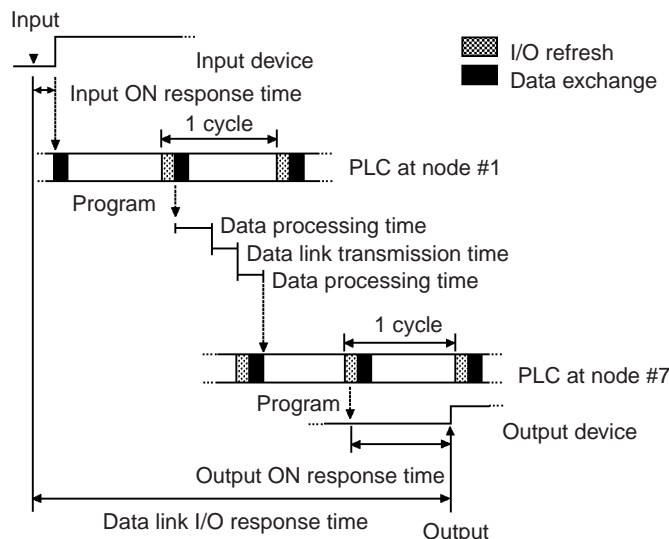

There are three points shown in the diagram above where processing is delayed, increasing the data link I/O response time.

In this case, both the input ON response time and output ON response time are considered negligible (0), but the data processing time required for data exchange and the time required for the data transmission itself cannot be ignored, so they are included in the total. The respective values are as follows:

Data processing time:
 $0.001 \times (8 + 16) + 0.1 = 0.124 \approx 0.1 \text{ ms}$

Data Link transmission time:

The following formula is derived from on the transmission speed.

$$0.008 \times \text{Number of data link words (ms)}$$

In this case, this gives the following result.

$$0.008 \times (8 + 16) = 0.19 \approx 0.2 \text{ ms}$$

Cycle time of PLC at node #1	25 ms
Data processing time	1.9 ms
Data link transmission time	0.2 ms
Data processing time	0.1 ms
PLC cycle time at node #7	10 ms
Total (data link I/O response time)	37.2 ms

Noise may increase I/O delays.

CVM1 and CV-series PLCs Under Asynchronous Operation

Maximum Data Link I/O Response Time

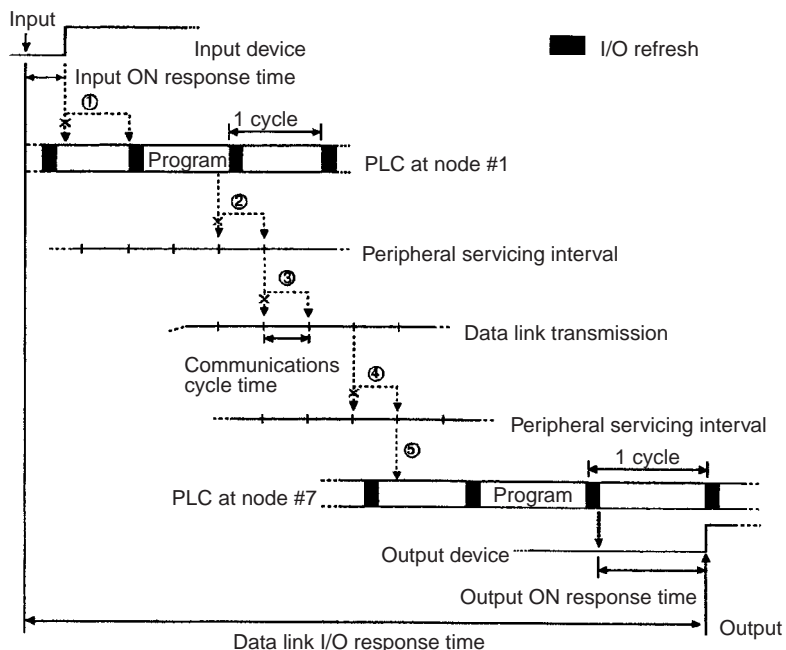

There are five points shown in the diagram above where processing is delayed, increasing the data link I/O response time.

- 1,2,3...
1. The input arrives in the PLC just after I/O refreshing, causing a delay of up to one cycle before the input is read into the PLC.
 2. Data exchange occurs just after the PLC at node #1 passes the token that makes it the polling node, causing a delay of up to one communications cycle time before the data is transferred in data link processing.
 3. At node #1, data from the previous data exchange is still being transferred, causing a delay of up to one cycle before the input is read into the PLC.
 4. The data transferred in data link processing arrives at the PLC at node #7 after data exchange, so the data will not be read into the PLC until the next data exchange, causing a delay of up to one peripheral servicing interval. Up to 3,700 words can be transferred in a single data exchange, so a delay of another peripheral servicing interval will occur if more than 3,700 words are being transferred.
 5. The data is received after the PLC at node #7 has executed the instruction, causing a delay of up to one cycle time.

Assume that the peripheral servicing interval of the PLCs at nodes #1 and #7 is 10 ms. The equation for the maximum data link I/O response time is as follows:

Input ON delay	1.5 ms
Cycle time of PLC at node #1 × 2	25 ms × 2
Peripheral servicing interval of PLC at node #1	10 ms
Communications cycle time × 2	22 ms × 2
Peripheral servicing interval of PLC at node #7 × 2	10 ms × 2
PLC cycle time at node #7 × 2	10 ms × 2
Output ON delay	15 ms
Total (data link I/O response time)	160.5 ms

Note Noise may increase I/O delays.

Minimum Data Link I/O Response Time

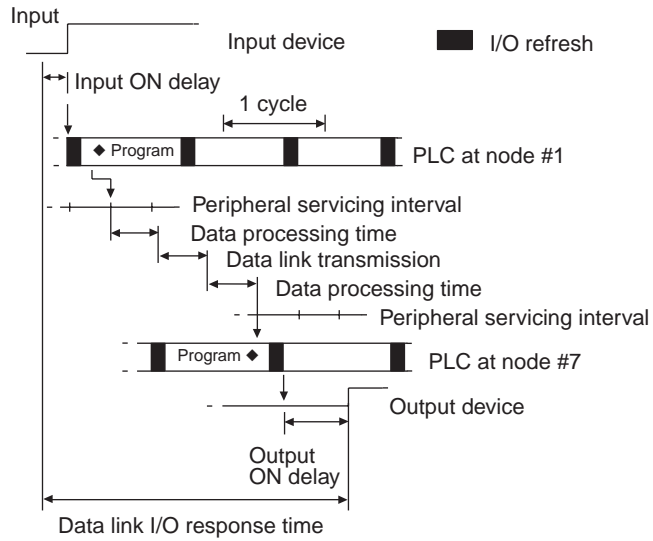

In this case, both the input ON response time and output ON response time are considered negligible (0), but the data processing time required for data exchange and the time required for the data transmission itself cannot be ignored, so they are included in the total. The respective values are as follows:

Data processing time:
 $0.001 \times (8 + 16) \times 8 + 1.7 = 1.89 \approx 1.9 \text{ ms}$

Data Link transmission time:

The following formula is derived based on the transmission speed.
 $0.008 \times (8 + 16) = 0.19 \approx 0.2 \text{ ms}$

Assume that the sum of the instruction execution time and I/O refresh time for the PLCs at nodes #1 and #7 is 1 ms. The equation for minimum data link I/O response time is as follows:

Instruction execution time + I/O refresh time for PLC at node #1	1 ms
Data processing time	1.9 ms
Data link transmission time	0.2 ms
Data processing time	1.9 ms
Instruction execution time + I/O refresh time for PLC at node #7	1 ms
Total (data link I/O response time)	6.0 ms

Noise may increase I/O delays.

9-4 Message Delay Times

The two charts which follow indicate the sequence of processing which will enable users to calculate the maximum delay time to be expected between the time SEND(192/90) or RECV(193/98) is executed and the time the data is stored in the remote or local node's memory area, ready for use by other instructions in the program.

9-4-1 CS-series, CVM1, and CV-series PLCs

SEND

The following diagram indicates the data flow which will yield the maximum delay time from the time SEND(192)/SEND(90) is executed by the user program to the time the Controller Link Unit stores the data in the remote Unit's memory.

Note Be sure to take into account the time required for data links and program execution, which are not included in the following example.

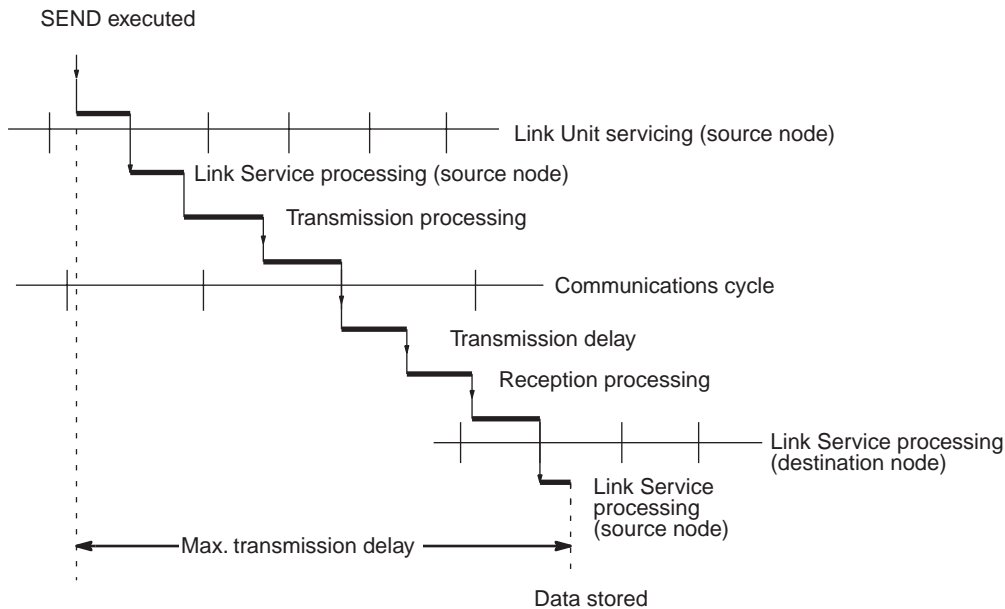

Max. transmission delay = Link Unit servicing interval (local node) + Link service processing (local node) + Transmission processing + Communications cycle time + Transmission delay + Reception processing + Link Unit servicing interval (remote node) + Link service processing (remote node)

Link Servicing Interval (Local and Remote Nodes)

Link servicing depends on the execution mode of the PLC. The execution modes on the local and remote modes need not be the same.

For synchronous execution, links are serviced once per PLC execution cycle. For asynchronous execution, links are serviced according to the peripheral servicing interval. Refer to the operation manual for the PLC for details. Refer to the *CVM1 and CV-series PLCs Operation Manual: Ladder Diagrams (W202)* or *CS/CJ-series PLCs Communications Commands Reference Manual (W342)* for details.

Link Service Processing (Local and Remote Nodes)

Link service processing is the same as the PLC’s peripheral servicing and is approximately 1 ms for Controller Link Units.

Transmission Processing

Number of words transferred × 0.00075 ms + 2 ms

Communications Cycle Time (with Data Links Inactive)

See 9-2 *Communications Cycle Time* (on page 221).

Transmission Delay Time

Number of words transferred × 0.008 + 0.112 ms

Reception Processing

Number of words transferred × 0.00075 + 1.3 ms

Note The I/O response time can increase due to noise or restrictions on the number of frames that can be transmitted while data links are operating.

Example

In this example, the maximum transmission delay is calculated for an instruction sending 256 words of data in a system with 32 nodes. Network specifics are detailed below:

H-PCF cable used
 Connection method: Ring connection
 Transmission distance: 8 km
 Transmission speed: 2 Mbps
 Max. node address: 62
 Number of nodes: 62
 Number of polled nodes per comm cycle: 4
 Local node execution: Synchronous
 Remote node execution: Asynchronous
 Number of words: 256
 Data link: Inactive

Link servicing interval (local node)	PLC cycle time (local node)
Link service processing (local node)	1 ms
Transmission processing	$0.00075 \times 256 + 2 = 2.192 \cong 2.2$ ms
Communications cycle time (See note.)	$1,740 \times 4 + 450 \times 62 + 1,100 \times 0 + 4 \times 0 + 2 \times 7 \times 8 + 3,000 = 37,972 \mu\text{s} \cong 38.0$ ms
Transmission delay	$0.008 \times 256 + 0.112 = 2.16 \cong 2.2$ ms
Reception processing	$0.00075 \times 256 + 1.13 = 1.492 \cong 1.5$ ms
Link servicing interval (remote node)	As required by Programming Device
Link service processing (remote node)	1 ms
Total (max. transmission delay)	PLC cycle time (local node) + Peripheral servicing interval (remote node) + 45.9 ms

Note This communications cycle time is calculated assuming that there is no node that transmits event frames before the SEND command is sent.

RECV Instruction Maximum Delay Time

The data flow which will yield the maximum transfer interval from the time the RECV(193)/RECV(98) instruction is executed by the user program to the time the Controller Link Unit stores the data in the local Unit's memory area is described below.

Note Be sure to take into account the time required for data links and program execution, which are not included in the following example.

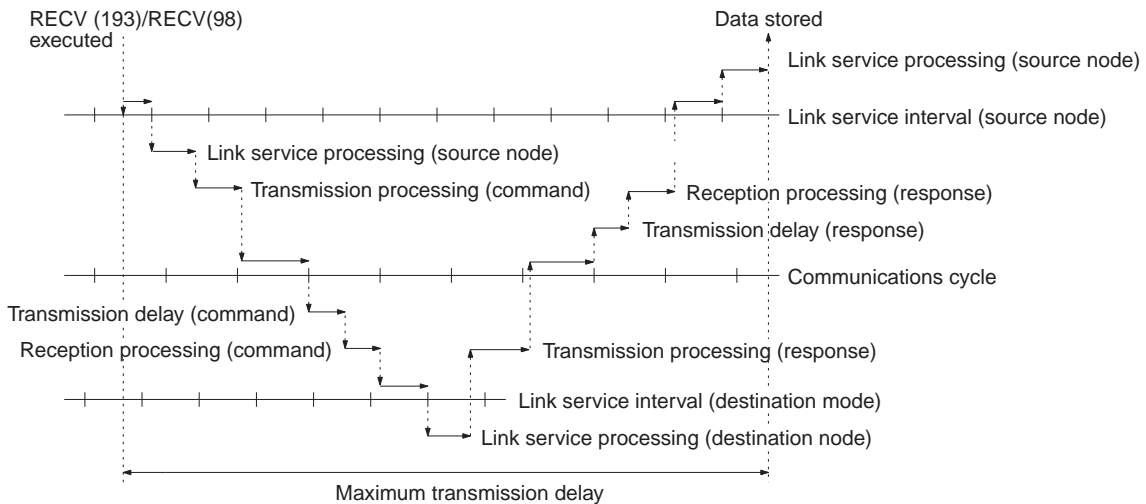

Max. transmission delay = Link servicing interval (local node) + Link service processing (local node) + Transmission processing (command) + Communications cycle + Transmission delay (command) + Reception processing (command) + Link servicing interval (remote node) + Link service processing (remote node) + Transmission processing (response) + Communications cycle + Transmission delay (response) + Reception processing (response) + Link servicing interval (local node) + Link service processing (local node).

Link Servicing Interval (Local and Remote Nodes)

Link servicing depends on the execution mode of the PLC. The execution modes on the local and remote modes need not be the same.

For synchronous execution, links are serviced once per PLC execution cycle. For asynchronous execution, links are serviced according to the peripheral servicing interval. Refer to the *CVM1 and CV-series PLCs Operation Manual: Ladder Diagrams (W202)* for details.

Link Service Processing (Local and Remote Nodes)

Link service processing is the same as the PLC’s peripheral servicing and is approximately 1 ms for Controller Link Units.

Transmission Processing

Commands: 2 ms

Responses: Number of words transferred × 0.00075 ms + 2 ms

Communications Cycle Time (with Data Links Inactive)

See 9-2 *Communications Cycle Time* (on page 221).

Transmission Delay Time

Number of words transferred × 0.008 + 0.112 ms

Note Commands: Transmission delay time is calculated assuming that the number of words to be transferred is zero.

Responses: Transmission delay time is calculated according to the number of words to be transferred.

Reception Processing

Commands: 1.3 ms

Responses: Number of words transferred × 0.00075 ms + 2 ms

The I/O response time can increase due to noise or restrictions on the number of frames that can be transmitted while the data link is operating.

Example

In this example, the maximum transmission delay is calculated for an instruction receiving 256 words of data in a system with 62 nodes. Network specifics are detailed below:

H-PCF cable used
 Connection method: Ring connection
 Transmission distance: 8 km
 Transmission speed: 2 Mbps
 Max. node address: 62
 Number of nodes: 62
 Number of polled nodes per comm cycle: 4
 Local node execution: Synchronous
 Remote node execution: Asynchronous
 Number of words: 256
 Data link: Inactive

Link Unit servicing (local node) × 2	PLC cycle time (local node) × 2
Link service processing (local node) × 2	1 ms × 2 = 2 ms
Transmission processing (command)	2 ms
Communications cycle × 2 (See note.)	$(1,740 \times 4 + 450 \times 62 + 1,100 \times 0 + 4 \times 0 + 2 \times 7 \times 8 + 3,000) \times 2 = 37,972 \mu\text{s} \times 2 \approx 75.9 \text{ ms}$
Transmission delay (command)	$0.112 \approx 0.1 \text{ ms}$
Reception processing (command)	1.3 ms
Link servicing interval (remote node)	As required by Programming Device (remote node)
Link service processing (remote node)	1 ms
Transmission processing (response)	$0.00075 \times 256 + 2 = 2.192 \approx 2.2 \text{ ms}$
Transmission delay (response)	$0.008 \times 256 + 0.112 = 2.16 \approx 2.2 \text{ ms}$
Reception processing (response)	$0.00075 \times 256 + 2 = 2.192 \approx 2.2 \text{ ms}$
Total (max. transmission delay)	PLC cycle time (local node) × 2 + Peripheral servicing time (remote node) + 88.9 ms

Note This communications cycle time is calculated assuming that there is no node that transmits event frames before the RECV command is sent.

SECTION 10

Troubleshooting and Maintenance

This section provides information on troubleshooting errors that occur during Controller Link Unit operation, as well as daily inspection, cleaning, and other maintenance procedures.

10-1	Troubleshooting Using Indicators	236
10-1-1	CS-series Controller Link Units	236
10-1-2	CVM1 and CV-series Controller Link Units	242
10-2	Status Area and Troubleshooting	247
10-2-1	CS-series Controller Link Units	247
10-2-2	CVM1 and CV-series Controller Link Units	254
10-3	Error Log	260
10-3-1	Error Log Table	260
10-3-2	Error Codes	261
10-3-3	Reading and Clearing Error Logs	267
10-4	Troubleshooting Error Messages	268
10-5	Locating and Correcting Cable Disconnections	270
10-5-1	Notification of Network Cable Disconnections	270
10-5-2	Cable Disconnection Examples	274
10-5-3	Correction of Network Cable Disconnections	276
10-5-4	Clearing the Ring Status Words	278
10-5-5	Reading the Ring Status	282
10-6	Troubleshooting for Duplex Communications Units	284
10-6-1	LED Indicators	284
10-6-2	Troubleshooting for Duplex Systems Using Indicators	285
10-7	Cleaning and Inspection	287
10-7-1	Cleaning	287
10-7-2	Inspection	288
10-8	Handling Precautions	288
10-8-1	Replacing Existing CS-series Models with New Models	288
10-8-2	Version Upgrade Functions for V1 or Higher Models	289
10-8-3	Replacing the Unit	289
10-8-4	Setting the Unit after Replacement	290
10-8-5	Replacing the Unit	292

10-1 Troubleshooting Using Indicators

This section describes the errors indicated by the Controller Link Unit indicators and possible remedies.

10-1-1 CS-series Controller Link Units

CS-series Optical Ring Controller Link Unit (H-PCF Cable)

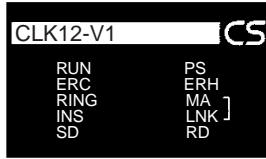

CS-series Optical Ring Controller Link Unit (GI Cable)

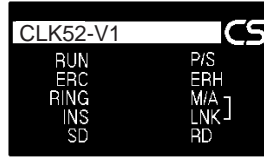

CS-series Optical Bus Controller Link Unit



RUN: Operating
 PS: Power being supplied
 ERC: Communications error
 RING: Transmission path format
 ERH: PC error
 INS: Network participation
 M/A: Data link mode
 LNK: Data link

Troubleshooting with RUN, P/S, ERC, ERH, RING, and INS Indicators

The RUN, P/S, ERC, ERH, RING, and INS indicators can be used to check whether Controller Link Unit startup and Network participation are operating normally.

Note Be sure to turn off the power to the PLC before performing any of the following.

- Disconnecting the Unit or connectors.
- Securing Units or connectors.
- Setting hardware switches.

The following CIO words contain information on the status of the Controller Link Unit. These words are referenced in the “Status area” column in the following table.

Error Information: CIO 1500 + 25 × (Unit No.) (See page 247)

Ring Status: CIO 1500 + 25 × (Unit No.) + 23 (See page 250)

Power Status: CIO 1500 + 25 × (Unit No.) + 24 (See page 254)

Indicators						Status area	Error code	Probable cause	Probable remedy
RUN	P/S	ERC	ERH	RING	INS				
Lit	---	Not lit	Not lit	Lit	Lit	---	---	The Unit started normally in token-ring mode and entered the network normally.	---
Lit	---	Not lit	Not lit	Not lit	Lit	---	---	The Unit started normally in token-bus mode and entered the network normally.	---
Flashing	---	Not lit	Not lit	Not lit	Not lit	---	---	Normal standby operation when used in duplex operation.	---

Indicators						Status area	Error code	Probable cause	Probable remedy
RUN	P/S	ERC	ERH	RING	INS				
Not lit	---	Not lit	Not lit	Not lit	Not lit	---	---	Power is not being supplied correctly to the PLC.	Check the power supply voltage and supply at the recommended voltage.
								The Controller Link Unit has become loose.	Secure the Controller Link Unit firmly.
								The Controller Link Unit is mounted in the wrong slot.	Refer to 3-2-2 CS1 and CS1-H PLCs and 3-2-3 CS1D PLCs in <i>Installation</i> and mount the Unit correctly.
								The Controller Link Unit is faulty.	If the indicators do not light when the Unit is mounted in another PLC, replace the Controller Link Unit.
---	Lit	---	---	---	---	Power status: Bit 11 ON Error information: Bit 15 ON	0216 Hex	The status of the backup power supply changed. (Backup power being supplied.)	The backup power supply may have gone OFF or come ON if error code 0216 is recorded in the error log. If possible, turn ON the backup power first and leave it ON during operation.
---	Not lit	---	---	---	---	Power status: Bit 11 OFF Error information: Bit 15 ON	0216 Hex	The status of the backup power supply changed. (Backup power not being supplied.)	The backup power supply may have gone OFF or come ON if error code 0216 is recorded in the error log. If possible, turn ON the backup power first and leave it ON during operation. Check the backup power supply and its cables.
Not lit	---	Lit	Not lit	---	Not lit	---	---	Controller Link Unit faulty.	If the ERC indicators still lights when the Unit is mounted on another PLC, replace the Controller Link Unit.
						---	0214 Hex	The node address is outside the setting range.	Set the node address to within the 1 to 62 range. (For the CS1W-CLK11, the range is 1 to 32.)

Indicators						Status area	Error code	Probable cause	Probable remedy
RUN	P/S	ERC	ERH	RING	INS				
---	---	Lit	Not lit	---	Not lit	Error information: Bits 12 and 15 ON	021B Hex	Hardware error in communications controller.	Replace the Controller Link Unit.
						Error information: Bits 11 and 15 ON	0210 Hex	Error in the communications controller's transmitter.	Replace the Controller Link Unit.
Lit	---	Lit	---	---	Not lit	Error information: Bits 09 and 15 ON	0211 Hex	The same node address is being used by two different Units.	Change so that each node address in the Network is unique.
								The transmission path format setting does not match the setting in the polling node.	Change the setting to match the one in the polling node and turn the power ON again.
Lit	---	---	Lit	---	---	Error information: Bit 15 ON	0001 Hex	An error has occurred in the PLC.	Refer to the PLC's operation manual and correct the error. If the error occurs again, replace the PLC.
							Error information: Bits 00 and 15 ON	0203 Hex	There is an error in the network parameters stored in the Controller Link Unit's EEPROM.
								021A Hex	The network parameter settings are incorrect or the local node address is larger than the maximum node address set in the network parameters.
						Error information: Bits 01 and 15 ON	0203 Hex	There is an error in the data link tables stored in the Controller Link Unit's EEPROM.	Set the data link tables again. If the error occurs again, replace the Controller Link Unit.
								021A Hex	The data link table settings are incorrect.
						Error information: Bits 02 and 15 ON	0203 Hex	There is an error in the routing table in the PLC's routing table area.	Set the routing tables again. If the error occurs again, replace the PLC.
								021A Hex	Routing table setting error

Indicators						Status area	Error code	Probable cause	Probable remedy
RUN	P/S	ERC	ERH	RING	INS				
Lit	---	---	---	---	Not lit	---	---	Cables are not connected correctly.	Check the cable connections are reconnect correctly.
								The node address is larger than the maximum node address set in the network parameters.	Either change the maximum node address setting with the Controller Link Support Software (Ver. 2.00 or later) or set a node address below the maximum.
								No other nodes exist.	Make sure that 2 or more nodes exist within the Network.
								No node has been set as the polling node.	Refer to 9-1-2 <i>Setting the Polling and Polled Nodes</i> and set the Controller Link Unit as the polling node. (If both types of optical Units are used in a network, use the Optical Ring Units as polled nodes.)
								The transmission path format setting is different in the polling node.	Change the setting to match the one in the polling node and turn the power ON again.
---	---	---	---	Flashing	Lit	Ring status: Bit 15 ON Error information: Bit 15 ON	021E Hex	A break was detected in the network cable. (Network operation continues.)	Determine the location of the break with the Controller Link Support Software (Ver. 2.00 or later) or the ring status word. Correct the break. Refer to 10-5 <i>Locating and Correcting Cable Disconnections</i> for details.
---	---	---	---	Flashing	Not lit	Ring status: Bit 15 ON Error information: Bit 15 ON	021E Hex	A break was detected in the network cable. (The Unit was out of the network after the error.)	

Troubleshooting with LNK and M/A Indicators

Data Link Cannot be Started

The following table describes the LNK and M/A indicators at the startup node and their use in troubleshooting when a data link cannot be started.

Starting a data link depends on the Controller Link Unit operating normally and participating in the Network. Refer to *Troubleshooting with RUN, ERC, ERH and INS Indicators* earlier in this section and check Unit operation before using the following table.

Indicators		Probable cause	Probable remedy
LNK	M/A		
Lit	---	Data link operating normally.	---
Flashing	---	There is an error in the data link tables.	When the ERH indicator is flashing, remake and set the data link tables.
		When manual setting is used, either data link tables have not been created for the startup node or there is an error in the data link tables.	Refer to <i>5-2-2 Manual Setting</i> and set data link tables for the startup node.
		When automatic setting is used, either the data link parameters for the startup node have not been set or there is an error in the data link tables.	Refer to <i>5-2-4 Automatic Setting: Select All</i> and set the automatic parameters for starting the data links.
		When a number exceeding 12,000 was set for the data link send and receive words or the same memory area was set for Area 1 and Area 2 using a Controller Link Unit with unit version 1.2 or later that was then replaced with a pre-Ver. 1.2 Controller Link Unit.	The number of data link send and receive words cannot exceed 12,000 and the same memory area cannot be set for Area 1 and Area 2 when using a pre-Ver. 1.2 Controller Link Unit. Either use a Controller Link Unit with unit version 1.2 or later or reset the data link tables.
Not lit	Lit	Manually set data links are already operating on the same Network.	Stop the manually set data links that are operating and restart the data links.
Not lit	Not lit	Automatically set data links are already operating on the same Network.	Stop the automatically set data links that are operating and restart the data links.
		There is an error in the startup node PLC.	Refer to the PLC's operation manual and correct the error. If the error reoccurs, replace the PLC.

Node Cannot Participate in Data Link

The following table describes the LNK and M/A indicators when a node cannot participate in the data links.

Data link participation depends on the Controller Link Unit operating normally and participating in the Network. Refer to *Troubleshooting with RUN, ERC, ERH and INS Indicators* earlier in this section and check Unit operation before using the following table.

Indicators		Probable cause	Probable remedy
LNK	M/A		
Lit	---	Data link operating normally.	---
Flashing	Lit	When manual setting is used, there is an error in the data link table.	Refer to 5-2-2 <i>Manual Setting</i> and remake the data link table.
Flashing	Not lit	When automatic setting is used, the data link parameters at the startup node are incorrect for the local node (the data link area is out of range for the local node.)	Refer to 5-2-4 <i>Automatic Setting: Select All</i> , reset the parameters for the startup node DM Area so that the local node can participate in the data link, and then restart the data link.
		When automatic setting is used, the local node is not set to participate in the data link at the startup node.	Stop the data link, reset the parameters for the startup node DM Area so that the local node can participate in the data link, and then restart the data link.
		When a number exceeding 12,000 was set for the data link send and receive words or the same memory area was set for Area 1 and Area 2 using a Controller Link Unit with unit version 1.2 or later that was then replaced with a pre-Ver. 1.2 Controller Link Unit.	The number of data link send and receive words cannot exceed 12,000 and the same memory area cannot be set for Area 1 and Area 2 when using a pre-Ver. 1.2 Controller Link Unit. Either use a Controller Link Unit with unit version 1.2 or later or reset the data link tables.
Not lit	Lit	When manual setting is used, there are no data link tables set for the local node.	Set data link tables for the local node.

Data Link Cannot be Stopped

Stopping the data link depends on the Controller Link Unit operating normally and participating in the Network. Read the above explanations before attempting to stop operation.

Note Stop the data link from the node at which the LNK indicator is lit (indicating active data links). Data links cannot be stopped from nodes which do not have active data links.

10-1-2 CVM1 and CV-series Controller Link Units

Optical Ring Controller Link Unit

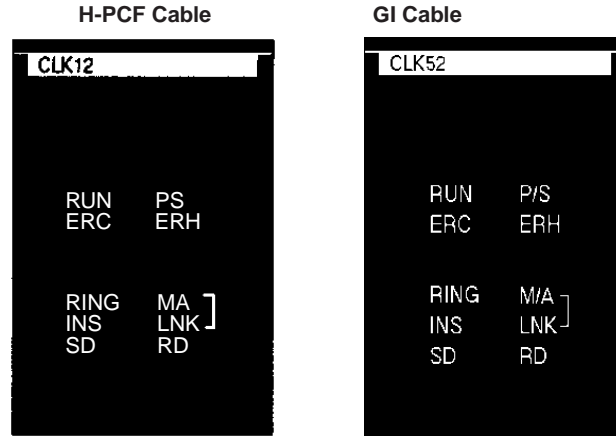

RUN: Operating
 PS: Power being supplied
 ERC: Communications error
 RING: Transmission path format
 ERH: PC error
 INS: Network participation
 M/A: Data link mode
 LNK: Data link

Troubleshooting with RUN, ERC, ERH, RING and INS Indicators

The RUN, ERC, ERH, RING and INS indicators can be used to check whether Controller Link Unit startup and Network participation are operating normally.

Note Be sure to turn off the power to the PLC before performing any of the following.

- Disconnecting the Unit or connectors.
- Securing Units or connectors.
- Setting hardware switches.

The following CIO words contain information on the status of the Controller Link Unit. These words are referenced in the "Status area" column in the following table.

Error Information: CIO 1500 + 25 × (Unit No.) (See page 254.)

Ring Status: CIO 1500 + 25 × (Unit No.) + 23 (See page 257.)

Power Status: CIO 1500 + 25 × (Unit No.) + 24 (See page 257.)

Indicators						Status area	Error code	Probable cause	Probable remedy
RUN	P/S	ERC	ERH	RING	INS				
Lit	---	Not lit	Not lit	Lit	Lit	---	---	The Unit started normally in token-ring mode and entered the network normally.	---
Lit	---	Not lit	Not lit	Not lit	Lit	---	---	The Unit started normally in token-bus mode and entered the network normally.	---

Indicators						Status area	Error code	Probable cause	Probable remedy
RUN	P/S	ERC	ERH	RING	INS				
Not lit	---	Not lit	Not lit	Not lit	Not lit	---	---	Power is not being supplied correctly to the PLC.	Check the power supply voltage and supply at the recommended voltage.
								The Controller Link Unit has become loose.	Secure the Controller Link Unit firmly.
								The Controller Link Unit is mounted in the wrong slot.	Refer to 3-2-1 CVM1 and CV-series PLCs and mount the Unit correctly.
								The Controller Link Unit is faulty.	If the indicators do not light when the Unit is mounted in another PLC, replace the Controller Link Unit.
---	Lit	---	---	---	---	Power status: Bit 11 ON Error information: Bit 15 ON	0216 Hex	The status of the backup power supply changed. (Backup power being supplied.)	The backup power supply may have gone OFF or come ON if error code 0216 is recorded in the error log. If possible, turn ON the backup power first and leave it ON during operation.
---	Not lit	---	---	---	---	Power status: Bit 11 OFF Error information: Bit 15 ON	0216 Hex	The status of the backup power supply changed. (Backup power not being supplied.)	The backup power supply may have gone OFF or come ON if error code 0216 is recorded in the error log. If possible, turn ON the backup power first and leave it ON during operation. Check the backup power supply and its cables.
Not lit	---	Lit	Not lit	---	Not lit	---	---	Controller Link Unit faulty.	If the ERC indicators still lights when the Unit is mounted on another PLC, replace the Controller Link Unit.
						Error information: Bit 15 ON	0214 Hex	The node address is outside the setting range.	Set the node address to within the 1 to 62 range.

Indicators						Status area	Error code	Probable cause	Probable remedy
RUN	P/S	ERC	ERH	RING	INS				
---	---	Lit	Not lit	---	Not lit	Error information: Bits 12 and 15 ON	021B Hex	Hardware error in communications controller.	Replace the Controller Link Unit.
						Error information: Bits 11 and 15 ON	0210 Hex	Error in the communications controller's transmitter.	Replace the Controller Link Unit.
Lit	---	Lit	---	---	Not lit	Error information: Bits 09 and 15 ON	0211 Hex	The same node address is being used by two different Units.	Change so that each node address in the Network is unique.
							0211 Hex	The transmission path format setting does not match the setting in the polling node.	Change the setting to match the one in the polling node and turn the power ON again.
Lit	---	---	Lit	---	---	Error information: Bit 15 ON	0001 Hex	An error has occurred in the PLC.	Refer to the PLC's operation manual and correct the error. If the error occurs again, replace the PLC.
							Error information: Bits 00 and 15 ON	0203 Hex	There is an error in the network parameters stored in the Controller Link Unit's EEPROM.
						Error information: Bits 01 and 15 ON		021A Hex	The network parameter settings are incorrect or the local node address is larger than the maximum node address set in the network parameters.
							Error information: Bits 02 and 15 ON	0203 Hex	There is an error in the data link tables stored in the Controller Link Unit's EEPROM.
						Error information: Bits 02 and 15 ON		021A Hex	The data link table settings are incorrect.
							Error information: Bits 02 and 15 ON	0203 Hex	There is an error in the routing table in the PLC's routing table area.
						Error information: Bits 02 and 15 ON		021A Hex	Routing table setting error

Indicators						Status area	Error code	Probable cause	Probable remedy
RUN	P/S	ERC	ERH	RING	INS				
Lit	---	---	---	---	Not lit	---	---	Cables are not connected correctly.	Check the cable connections are reconnect correctly.
								The node address is larger than the maximum node address set in the network parameters.	Either change the maximum node address setting with the Controller Link Support Software (Ver. 2.00 or higher) or set a node address below the maximum.
								No other nodes exist.	Make sure that 2 or more nodes exist within the Network.
								No node has been set as the polling node.	Refer to 9-1-2 <i>Setting the Polling and Polled Nodes</i> and set the Controller Link Unit as the polling node. (If both types of optical Units are used in a network, use the Optical Ring Units as polled nodes.)
								The transmission path format setting is different in the polling node.	Change the setting to match the one in the polling node and turn the power ON again.
---	---	---	---	Flashing	Lit	Ring status: Bit 15 ON Error information: Bit 15 ON	021E Hex	A break was detected in the network cable. (Network operation continues.)	Determine the location of the break with the Controller Link Support Software (Ver. 2.00 or higher) or the ring status word. Correct the break. Refer to 10-5 <i>Locating and Correcting Cable Disconnections</i> for details.
---	---	---	---	Flashing	Not lit	Ring status: Bit 15 ON Error information: Bit 15 ON	021E Hex	A break was detected in the network cable. (The Unit was out of the network after the error.)	

Troubleshooting with LNK and M/A Indicators

Data Link Cannot be Started

The following table describes the LNK and M/A indicators at the startup node and their use in troubleshooting when a data link cannot be started.

Starting a data link depends on the Controller Link Unit operating normally and participating in the Network. Refer to *Troubleshooting with RUN, ERC, ERH and INS Indicators* earlier in this section and check Unit operation before using the following table.

Indicators		Probable cause	Probable remedy
LNK	M/A		
Lit	---	Data link operating normally.	---
Flashing	---	There is an error in the data link tables.	When the ERH indicator is flashing, remake and set the data link tables.
		When manual setting is used, either data link tables have not been created for the startup node or there is an error in the data link tables.	Refer to 5-2-2 <i>Manual Setting</i> and set data link tables for the startup node.
		When automatic setting is used, either the data link parameters for the startup node have not been set or there is an error in the data link tables.	Refer to 5-2-4 <i>Automatic Setting: Select All</i> and set the automatic parameters for starting the data links.
		Automatic setting is used with 1:N allocations, but the device does not support this function.	Use a Controller Link Unit that supports automatic data link creation with 1:N allocations. Refer to <i>Automatic Setting, Equality Layout</i> on page 110 for details.
Not lit	Lit	Manually set data links are already operating on the same Network.	Stop the manually set data links that are operating and restart the data links.
Not lit	Not lit	Automatically set data links are already operating on the same Network.	Stop the automatically set data links that are operating and restart the data links.
		There is an error in the startup node PLC.	Refer to the PLC's operation manual and correct the error. If the error reoccurs, replace the PLC.

Node Cannot Participate in Data Link

The following table describes the LNK and M/A indicators when a node cannot participate in the data links.

Data link participation depends on the Controller Link Unit operating normally and participating in the Network. Refer to *Troubleshooting with RUN, ERC, ERH and INS Indicators* earlier in this section and check Unit operation before using the following table.

Indicators		Probable cause	Probable remedy
LNK	M/A		
Lit	---	Data link operating normally.	---
Flashing	Lit	When manual setting is used, there is an error in the data link table.	Refer to 5-2-2 <i>Manual Setting</i> and remake the data link table.
Flashing	Not lit	When automatic setting is used, the data link parameters at the startup node are incorrect for the local node (the data link area is out of range for the local node.)	Refer to 5-2-4 <i>Automatic Setting: Select All</i> , reset the parameters for the startup node DM Area so that the local node can participate in the data link, and then restart the data link.
		Automatic setting is used with 1:N allocations, but the device does not support this function.	Use a Controller Link Unit that supports automatic data link creation with 1:N allocations. Refer to <i>Automatic Setting, Equality Layout</i> on page 110 for details.

Indicators		Probable cause	Probable remedy
LNK	M/A		
Not lit	Lit	When manual setting is used, there are no data link tables set for the local node.	Set data link tables for the local node.
Not lit	Not lit	When automatic setting is used, the startup node is not set to participate in the data links.	Stop the data links, remake and set the parameters in the startup node's DM Area, and then restart the data link.

Data Link Cannot be Stopped

Stopping the data link depends on the Controller Link Unit operating normally and participating in the Network. Read the above explanations before attempting to stop operation.

Note Stop the data link from the node at which the LNK indicator is lit (indicating active data links). Data links cannot be stopped from nodes which do not have active data links.

10-2 Status Area and Troubleshooting

The status of the Unit and the communications status of the Controller Link Unit is recorded in the Status Area of the PLC. The cause of errors can be found by searching the Status Area. The Status Area can be read using a Programming Console, or the Controller Link Support Software.

This section explains the contents of the Status Area and tells how to troubleshoot errors recorded there.

10-2-1 CS-series Controller Link Units

The status of the Unit and Network is indicated in the following manner in the PLC.

Status information related to duplex operation of Communications Units is reflected in the PLC's Auxiliary Area. For details, refer to *10-1 Troubleshooting Using Indicators and Auxiliary Area* on page 309.

Status Area

Error Information: CIO 1500 + 25 x (Unit No.)

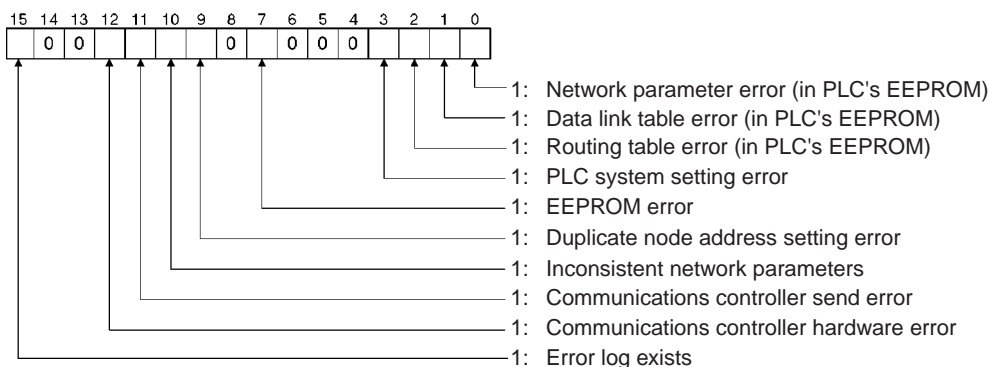

Polling Node Address, Startup Node Address: CIO 1500 + 25 x (Unit No.) + 1

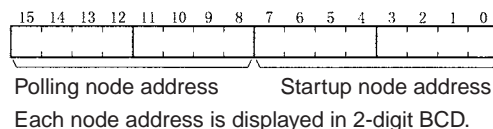

Network Participation Status: CIO 1500 + 25 x (Unit No.) + 2 to + 5

	15	14	13	12	11	10	9	8	7	6	5	4	3	2	1	0
+2	16	15	14	13	12	11	10	9	8	7	6	5	4	3	2	1
+3	32	31	30	29	28	27	26	25	24	23	22	21	20	19	18	17
+4	48	47	46	45	44	43	42	41	40	39	38	37	36	35	34	33
+5	-	-	62	61	60	59	58	57	56	55	54	53	52	51	50	49

-: Not used

The numbers in the squares correspond to node addresses.
 The bit status indicates each node's participation status as follows:
 0: Not part of the network
 1: Part of the network

Note When the local node is not part of the network, the local node's participation status bit will be 0. The participation status of other nodes will not be reliable in this case.

Local Data Link Participation Status: CIO 1500 + 25 x (Unit No.) + 6

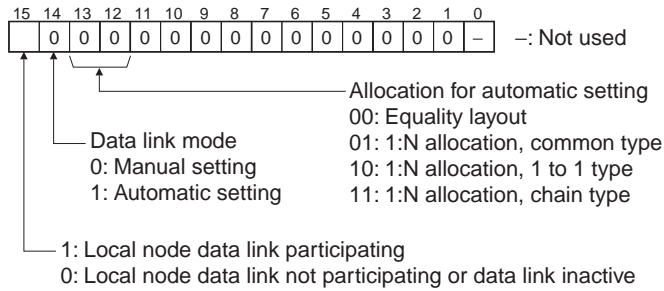

Note Data link status is valid only when the local node is participating in the data link. Confirm that the Local Data Link Participation Flag is ON before referencing the data link status.

Data Link Status: CIO 1500 + 25 x (Unit No.) + 7 to + 22

8 Bit Format Specified

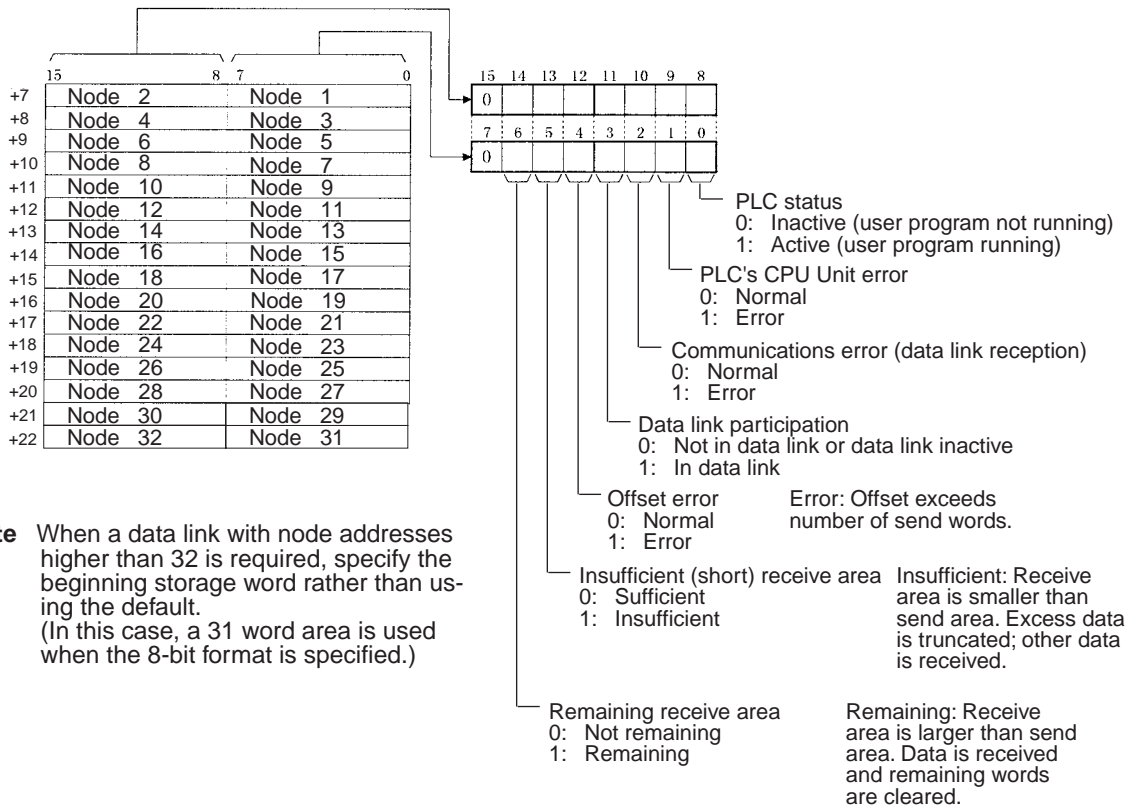

Note When a data link with node addresses higher than 32 is required, specify the beginning storage word rather than using the default. (In this case, a 31 word area is used when the 8-bit format is specified.)

4 Bit Format Specified

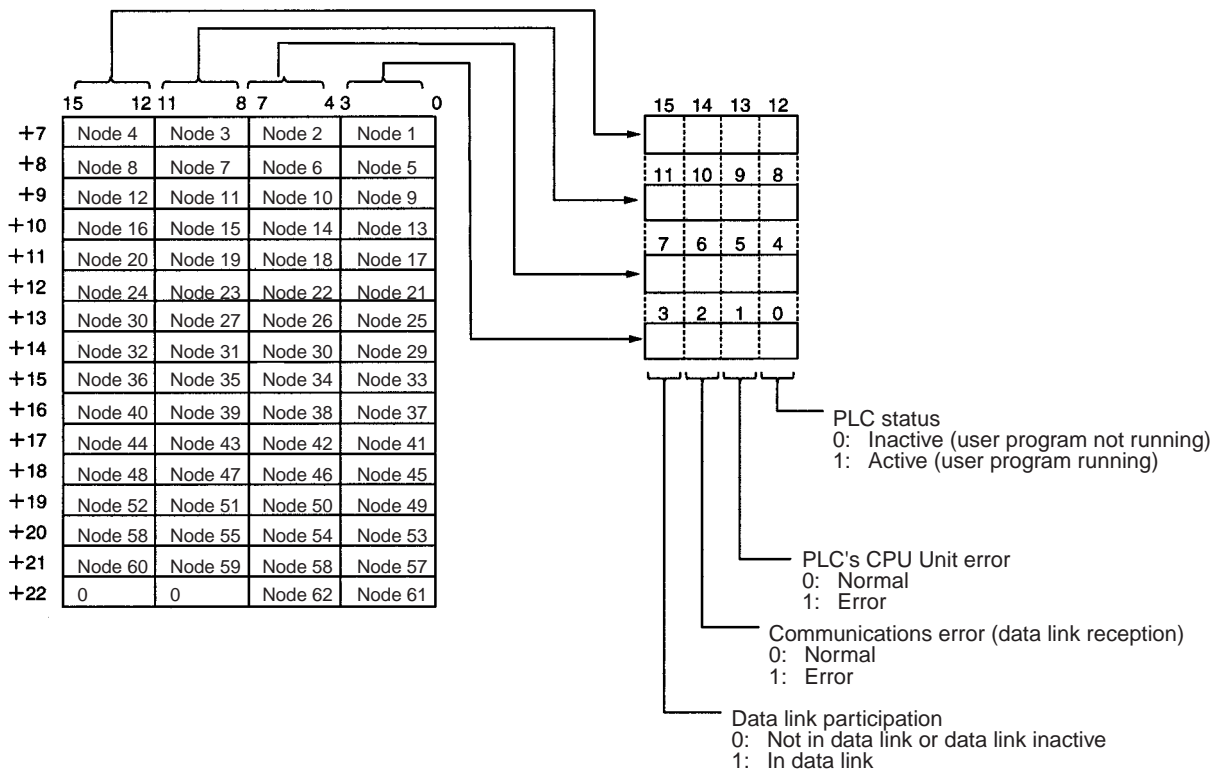

When the first data link status word is set to the default (0000) for either the manually set data link tables or automatically set data link tables (In the first data link status word parameter), the data link status is stored in the above area (CIO 1500 + 25 × (Unit No.) (+ 7 to +22)).

When a different area has been set for the first data link status word, the status is stored in the specified area. The status storage format is the same as the one shown in the above diagram. When the 8-bit format is specified, the area contains 31 words in order to contain the status information for node addresses 1 to 62.

Note Refer to 5-4 Checking Data Link Status for details on status flags.

Ring Status: CIO 1500 + 25 x (Unit No.) + 23

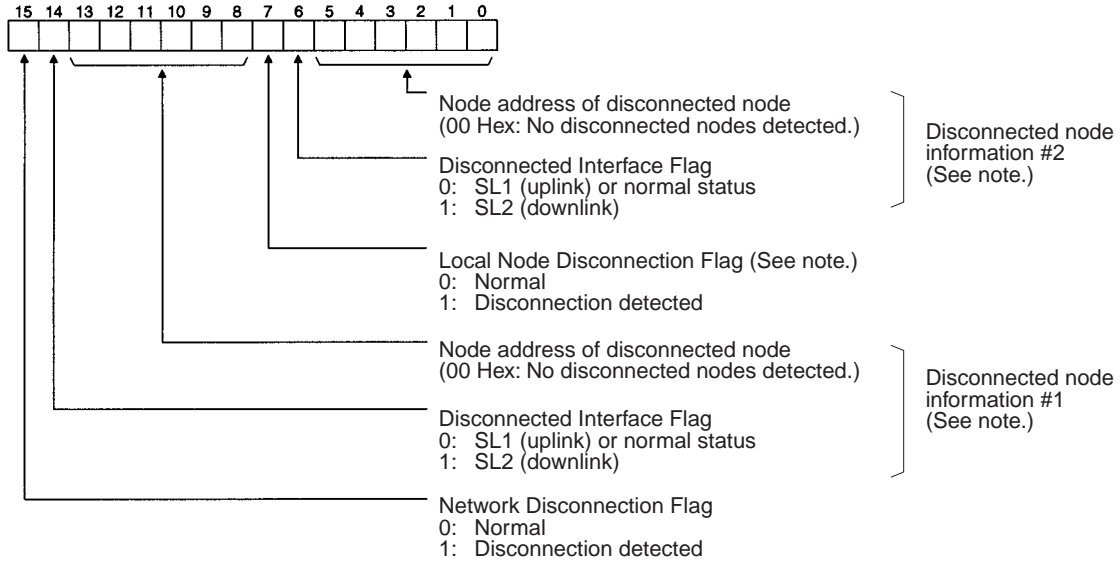

Note The disconnected node information is valid only when bit 15 (the Network Disconnection Flag) is ON. If bit 15 is OFF, the earlier disconnected node information and Local Node Disconnection Flag status is retained.

Power Status: CIO 1500 + 25 x (Unit No.) + 24

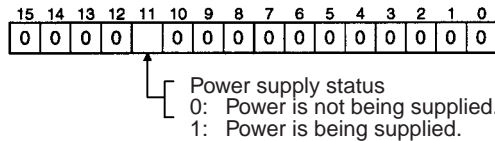

Bit Status and Error Processing

Data Link Status

Bit status	Probable cause	Probable remedy
PLC's CPU Unit error is 1: ON	A fatal PLC error, non-fatal PLC error, or a watchdog timer error has occurred.	Refer to the PLC's operation manual and correct the error. If the error occurs again, replace the PLC.
	The Unit is mounted to a non-compatible PLC.	Refer to <i>1-2-5 Controller Link Unit Models and PLCs</i> and mount onto the correct PLC.
Communications error is 1: ON	The relevant node is not in the Network.	Enter the node in the Network.
	A communications error has occurred as a result of noise.	Conduct an echoback test using the Controller Link Support Software and if this does not correct the error, check the usage environment.
	A communications error has occurred.	Refer to page 242 <i>Troubleshooting with RUN, ERC, RING and INS Indicators</i> and troubleshoot accordingly.
Data link participation is 0: OFF	The relevant node is not part of data links.	Enter the relevant node in data links. If an error occurs, refer to page 246 <i>Node Cannot Participate in Data Link</i> and troubleshoot accordingly.
	There are no active data links in the Network.	Activate the data links.
Offset error is 1: ON	The offset is greater than the number of send words at the relevant node.	Check the number of send words at the relevant node, the number of receive words at the local node and the offset, then reset the data link table correctly.

Bit status	Probable cause	Probable remedy
Receive area insufficient (short) is 1: ON	The send area at the relevant node is larger than the receive area and some data cannot be received.	When the intention is not to receive all data, use as is (data that cannot be received will be read and discarded.) When it differs from the intended data link, check the number of send words at the relevant node, the number of receive words at the local node and the offset, then reset the data link table correctly.
Receive area remaining is 1: ON	The send area at the relevant node is smaller than the receive area and some of the area will be unused.	When the intention is to leave some space in the receive area, use as is (the surplus receive area will be cleared to 0.) When it differs from the intended data link, check the number of send words at the relevant node, the number of receive words at the local node and the offset, then reset the data link table correctly.

Other Status

Bit status	Probable cause	Probable remedy
Error log exists (CIO 1500 + 25 × n, bit 15) is 1: ON	Error information on the Controller Link Unit (an error log) has been recorded.	Using the Controller Link Support Software or an FINS command, read the cause of the current error. Alternatively, use past error log records to troubleshoot the problem.
Communications controller send error (CIO 1500 + 25 × n, bit 11) is 1: ON	The Controller Link Unit is faulty.	Replace the Controller Link Unit.
Inconsistent network parameters (CIO 1500 + 25 × n, bit 10) is 1: ON	Indicates that the network parameters recorded in the CPU Bus Unit Area differ from the values of the Network in use.	Check the network parameters on the Network in use using the Controller Link Support Software, and reset necessary parameters.
Node address duplicate setting error (CIO 1500 + 25 × n, bit 9) is 1: ON	The same node address has been used more than once.	Reset so that each node address is used only once within the same Network (except for Units used in duplex operation).
	The Unit is connected to a SYSMAC LINK network (Optical Units only).	Check the network and reconnect cables correctly.
EEPROM error (CIO 1500 + 25 × n, bit 7) is 1: ON	An error has occurred while writing data to the EEPROM in the Controller Link Unit.	Check the status of bits 00 to 02 in CIO 1500 + 25 × n, and correct any problems found. If the error occurs again, replace the CPU Unit.

Bit status	Probable cause	Probable remedy
PLC system setting error (CIO 1500 + 25 × n, bit 3) is 1: ON	Data is corrupted in the CPU Bus Unit system setup in the CPU Unit.	Check the status of bits 00 to 02 in CIO 1500 + 25 × n, and correct any problems found. If the error occurs again, replace the CPU Unit.
	The PLC is protected.	Set the PLC's protect switch to OFF.
Routing table error (CIO 1500 + 25 × n, bit 2) is 1: ON	The routing table data in the CPU Unit's Parameter Area is corrupted.	Refer to <i>7-4 Setting Routing Tables</i> and reset the routing tables correctly. If the error occurs again, replace the Controller Link Unit.
	There is an error in the routing table setting.	When using a routing table, refer to <i>7-4 Setting Routing Tables</i> and reset the routing tables correctly. If no routing tables are being used, delete the tables.
Data link table error (CIO 1500 + 25 × n, bit 1) is 1: ON	The data link table data in the CPU Bus Unit Area is damaged.	Refer to <i>5-3 Starting and Stopping Data Links</i> and reset the data link tables correctly. If the error occurs again, replace the CPU Unit.
	There is an error in the data link table settings.	When using manually set data links, refer to <i>5-3 Starting and Stopping Data Links</i> and remake and set the data link tables correctly. When manually set data links are not being used, delete the data link tables.

Bit status	Probable cause	Probable remedy
Network parameter error (CIO 1500 + 25 × n, bit 0) is 1: ON	The network parameter data in the CPU Bus Unit Area is damaged.	Refer to 9-1-3 <i>Network Parameters</i> and reset the data correctly. If the error occurs again, replace the CPU Unit. Either set the EEPROM Clear Bit in the DM parameter area to ON, or use the Initialize network parameters operation on the Maintenance Menu of the Controller Link Support Software to initialize the network parameters and then cycle the power supply.
	There is an error in the network parameter settings, or node address of the local node is larger than the maximum address set within the network parameters.	Refer to 9-1-3 <i>Network Parameters</i> and reset the network parameters or the node address.

10-2-2 CVM1 and CV-series Controller Link Units

The status of the Unit and Network is indicated in the following manner in the PLC.

Status Area

Error Information: CIO 1500 + 25 x (Unit No.)

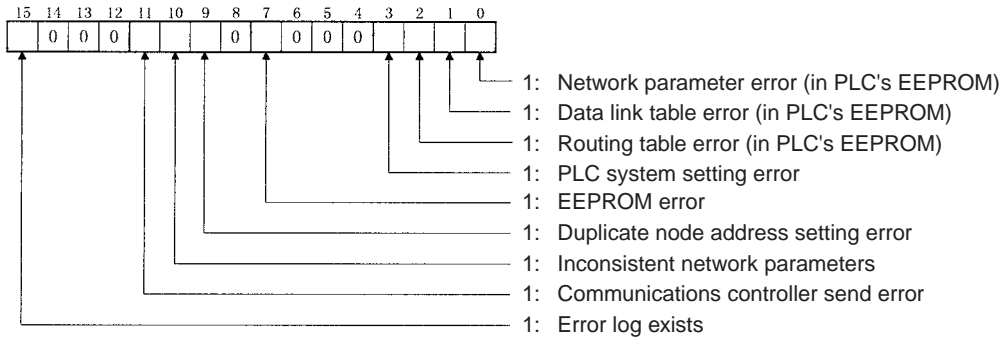

Polling Node Address, Startup Node Address: CIO 1500 + 25 x (Unit No.) + 1

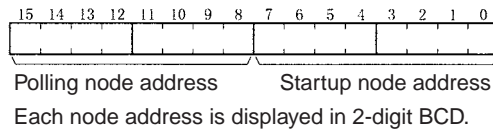

Network Participation Status: CIO 1500 + 25 x (Unit No.) + 2 to + 5

	15	14	13	12	11	10	9	8	7	6	5	4	3	2	1	0
+2	16	15	14	13	12	11	10	9	8	7	6	5	4	3	2	1
+3	32	31	30	29	28	27	26	25	24	23	22	21	20	19	18	17
+4	48	47	46	45	44	43	42	41	40	39	38	37	36	35	34	33
+5	—	—	62	61	60	59	58	57	56	55	54	53	52	51	50	49

—: Not used

The numbers in the squares correspond to node addresses.
 The bit status indicates each node's participation status as follows:
 0: Not part of the network
 1: Part of the network

Note When the local node is not part of the network, the local node's participation status bit will be 0. The participation status of other nodes will not be reliable in this case.

Local Data Link Participation Status: CIO 1500 + 25 x (Unit No.) + 6

15	14	13	12	11	10	9	8	7	6	5	4	3	2	1	0
0	0	0	0	0	0	0	0	0	0	0	0	0	0	0	0

1: Local node data link participating
 0: Local node data link not participating or data link inactive

Note Data link status is enabled only when the local node is participating in the data links. Make sure that the Local Node Participation Flag is ON before checking data link status.

Data Link Status: CIO 1500 + 25 x (Unit No.) + 7 to + 22

8 Bit Format Specified

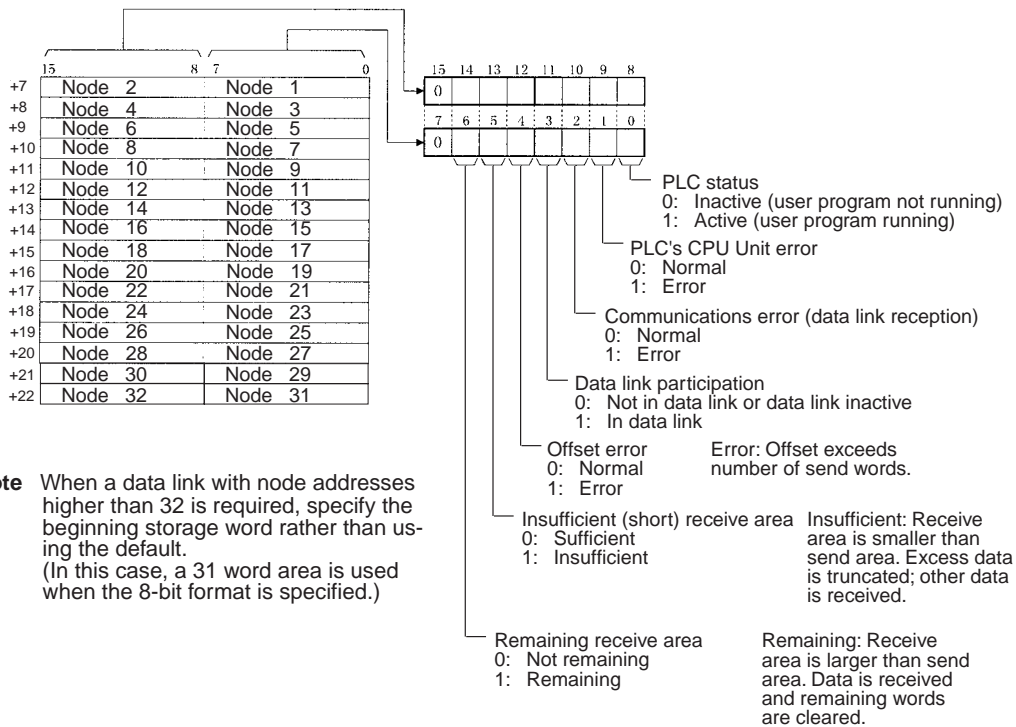

Note When a data link with node addresses higher than 32 is required, specify the beginning storage word rather than using the default. (In this case, a 31 word area is used when the 8-bit format is specified.)

4 Bit Format Specified

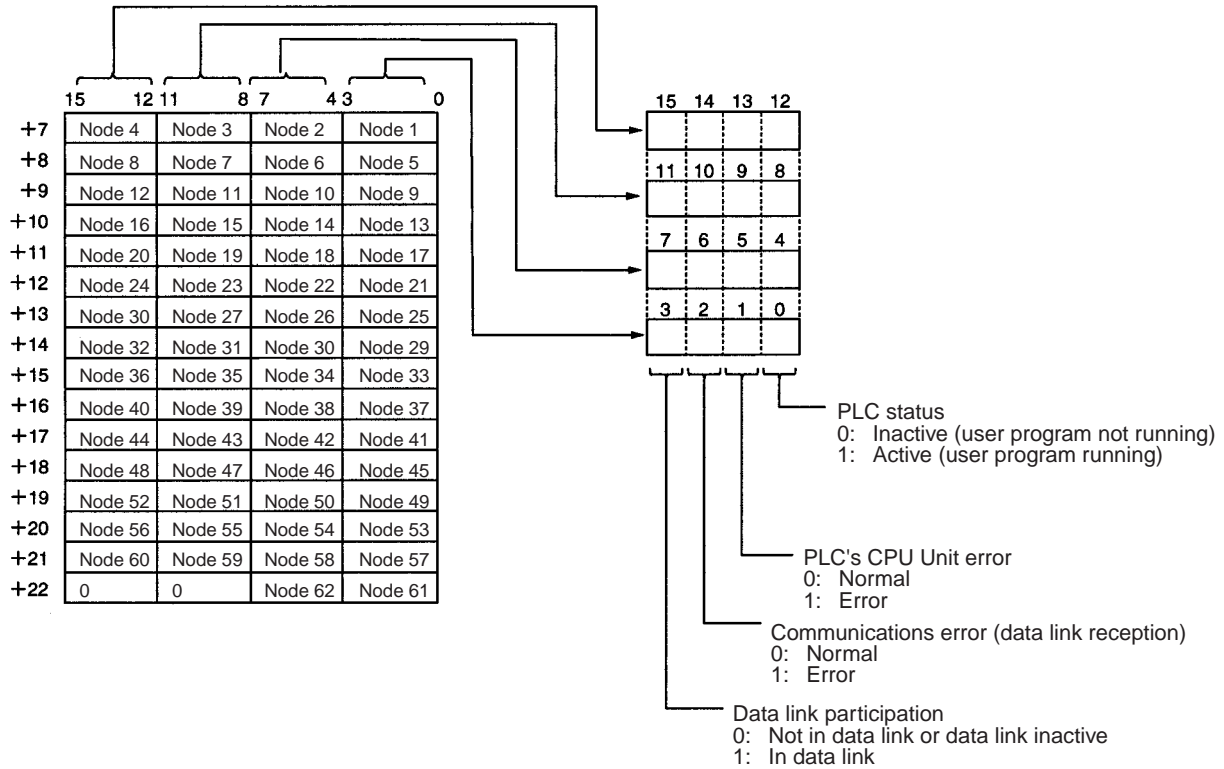

When the first data link status word is set to the default (0000) for either the manually set data link tables or automatically set data link tables (In the first data link status word parameter), the data link status is stored in the above area (CIO 1500 + 25 × (Unit No.) (+ 7 to +22)).

When a different area has been set for the first data link status word, the status is stored in the specified area. The status storage format is the same as the one shown in the above diagram. When the 8-bit format is specified, the area contains 31 words in order to contain the status information for node addresses 1 to 62.

Note Refer to 5-4 Checking Data Link Status for details on status flags.

Ring Status: CIO 1500 + 25 x (Unit No.) + 23

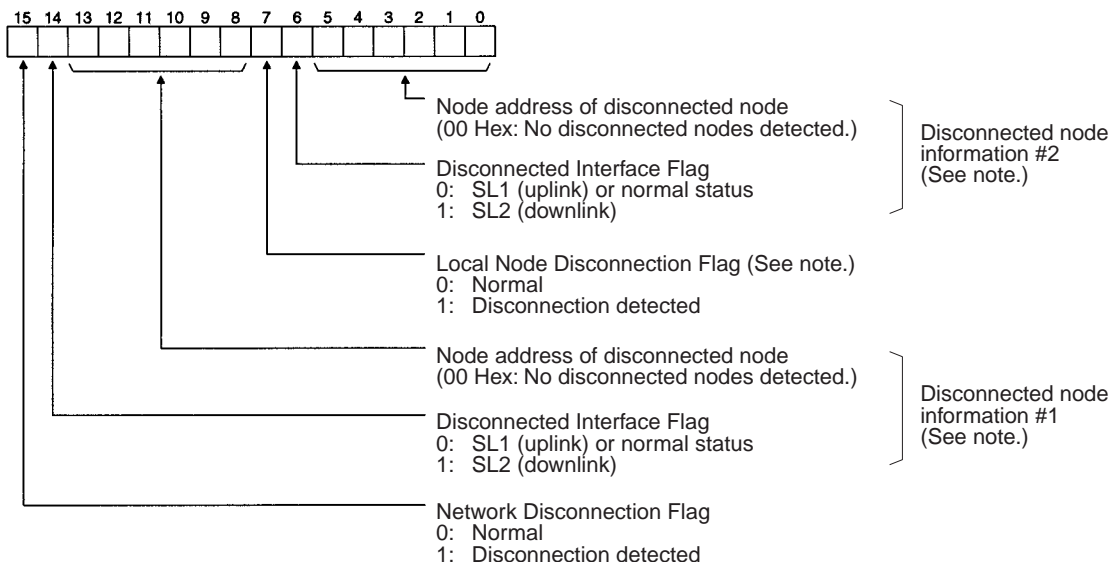

Note The disconnected node information is valid only when bit 15 (the Network Disconnection Flag) is ON. If bit 15 is OFF, the earlier disconnected node information and Local Node Disconnection Flag status is retained.

Power Status: CIO 1500 + 25 x (Unit No.) + 24

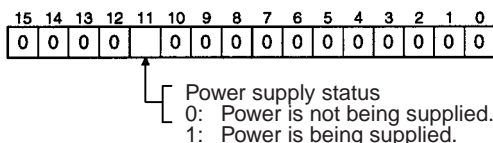

Bit Status and Error Processing

Data Link Status

Bit status	Probable cause	Probable remedy
PLC's CPU Unit error is 1: ON	A fatal PLC error, non-fatal PLC error, or a watchdog timer error has occurred.	Refer to the PLC's operation manual and correct the error. If the error occurs again, replace the PLC.
	The Unit is mounted to a non-compatible PLC.	Refer to 1-2-5 <i>Controller Link Unit Models and PLCs</i> and mount onto the correct PLC.
Communications error is 1: ON	The relevant node is not in the Network.	Enter the node in the Network.
	A communications error has occurred as a result of noise.	Conduct an echoback test using the Controller Link Support Software and if this does not correct the error, check the usage environment.
	A communications error has occurred.	Refer to page 242 <i>Troubleshooting with RUN, ERC, ERH, RING and INS Indicators</i> and troubleshoot accordingly.

Bit status	Probable cause	Probable remedy
Data link participation is 0: OFF	The relevant node is not part of data links.	Enter the relevant node in data links. If an error occurs, refer to page 246 <i>Node Cannot Participate in Data Link</i> and troubleshoot accordingly.
	There are no active data links in the Network.	Activate the data links.
Offset error is 1: ON	The offset is greater than the number of send words at the relevant node.	Check the number of send words at the relevant node, the number of receive words at the local node and the offset, then reset the data link table correctly.
Receive area insufficient (short) is 1: ON	The send area at the relevant node is larger than the receive area and some data cannot be received.	When the intention is not to receive all data, use as is (data that cannot be received will be read and discarded.) When it differs from the intended data link, check the number of send words at the relevant node, the number of receive words at the local node and the offset, then reset the data link table correctly.
Receive area remaining is 1: ON	The send area at the relevant node is smaller than the receive area and some of the area will be unused.	When the intention is to leave some space in the receive area, use as is (the surplus receive area will be cleared to 0.) When it differs from the intended data link, check the number of send words at the relevant node, the number of receive words at the local node and the offset, then reset the data link table correctly.

Other Status

Bit status	Probable cause	Probable remedy
Error log exists (CIO 1500 + 25 × n, bit 15) is 1: ON	Error information on the Controller Link Unit (an error log) has been recorded.	Using the Controller Link Support Software or an FINS command, read the cause of the current error. Alternatively, use past error log records to troubleshoot the problem.
Communications controller send error (CIO 1500 + 25 × n, bit 11) is 1: ON	The Controller Link Unit is faulty.	Replace the Controller Link Unit.
Inconsistent network parameters (CIO 1500 + 25 × n, bit 10) is 1: ON	Indicates that the network parameters recorded in the CPU Unit's EEPROM differ from the values of the Network in use.	Check the network parameters on the Network in use using the Controller Link Support Software, and reset necessary parameters.
Node address duplicate setting error (CIO 1500 + 25 × n, bit 9) is 1: ON	The same node address has been used more than once.	Reset so that each node address is used only once within the same Network.

Bit status	Probable cause	Probable remedy
EEPROM error (CIO 1500 + 25 × n, bit 7) is 1: ON	An error has occurred while writing data to the CPU Unit's EEPROM.	Check the status of bits 00 to 02 in CIO 1500 + 25 × n, and correct any problems found. If the error occurs again, replace the CPU Unit.
PLC system setting error (CIO 1500 + 25 × n, bit 3) is 1: ON	The CPU Unit's EEPROM data is damaged.	Check the status of bits 00 to 02 in CIO 1500 + 25 × n, and correct any problems found. If the error occurs again, replace the CPU Unit.
	The PLC is protected.	Set the PLC's protect switch to OFF.
Routing table error (CIO 1500 + 25 × n, bit 2) is 1: ON	The routing table data within the CPU Unit's EEPROM is damaged.	Refer to <i>7-4 Setting Routing Tables</i> and reset the routing tables correctly. If the error occurs again, replace the Controller Link Unit.
	There is an error in the routing table setting.	When using a routing table, refer to <i>7-4 Setting Routing Tables</i> and reset the routing tables correctly. If no routing tables are being used, delete the tables.
Data link table error (CIO 1500 + 25 × n, bit 1) is 1: ON	The data link table data in the EEPROM of the CPU Unit is damaged.	Refer to <i>5-3 Starting and Stopping Data Links</i> and reset the data link tables correctly. If the error occurs again, replace the CPU Unit.
	There is an error in the data link table settings.	When using manually set data links, refer to <i>5-3 Starting and Stopping Data Links</i> and remake and set the data link tables correctly. When manually set data links are not being used, delete the data link tables.

Bit status	Probable cause	Probable remedy
Network parameter error (CIO 1500 + 25 × n, bit 0) is 1: ON	The CPU Unit's EEPROM data link tables or the network parameters are damaged.	Refer to 9-1-3 <i>Network Parameters</i> and reset the data correctly. If the error occurs again, replace the CPU Unit.
		Either set the EEPROM Clear Bit in the DM parameter area to ON, or use the Initialize network parameters operation on the Maintenance Menu of the Controller Link Support Software to initialize the network parameters and then cycle the power supply.
	There is an error in the network parameter settings, or node address of the local node is larger than the maximum address set within the network parameters.	Refer to 9-1-3 <i>Network Parameters</i> and reset the network parameters or the node address.

10-3 Error Log

The error log records errors that occur in the Controller Link Unit and the time they occur. The error log can be read or cleared using the Controller Link Support Software, the CX-Programmer, or a message service (FINS commands for the Controller Link Unit).

10-3-1 Error Log Table

Errors are recorded in an error log table in the Unit's RAM, with one record for each error and a maximum of 64 or 39 records.

Errors of significance are also recorded in the Unit's EEPROM so that when the power to the Unit is turned OFF or reset, a record of the error will remain. (The error log table in EEPROM automatically reads the Unit's RAM when the power is turned ON again.)

Item	Specification
No. of records	64 records max.: CS1W-CLK13 and CS1W-CLK53 39 records max.: All other Units
Data code	Binary (Times are in BCD)
Length of each record	10 bytes
Configuration of records	Error code: 2 bytes (Refer to page 261.) Detail code: 2 bytes (Refer to page 261.) Time: 6 bytes (Refer to the following page.)
Record order	From the oldest record to the most recent.

If the number of records exceeds 64 or 39, the oldest record will be deleted and the most recent error recorded.

Error Log Table Configuration

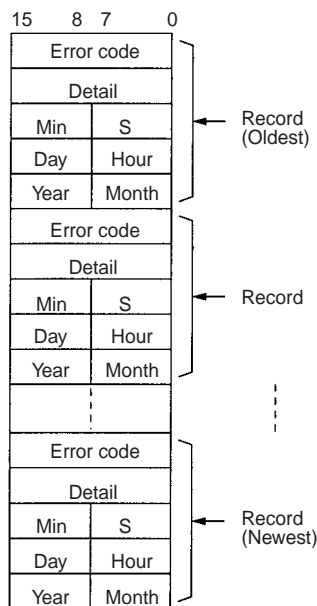

Time Information

The time is recorded in BCD with one byte each for the year (the rightmost two digits), month, day, hour, seconds, and minutes of the time the error occurred.

- Note**
1. The PLC's time information can be read and used in the Controller Link Unit. When the time cannot be read from the PLC, all error log times will be 0. This can occur for PLC startup errors, Unit No. errors, CPU Unit errors, or PLC model errors. When error logs like these are read from the Controller Link Support Software, they will be dated 0 s, 0 min, 0 hr, 0 day, 0 month, 2000.
 2. When replacing the battery for CS-series PLCs, it will be necessary to switch the power supply ON and reset the internal clock. If the internal clock is not reset, time information in the error log will not be recorded correctly.
 3. The time information will be all zeros for CQM1H-series PLCs unless a Memory Cassette with a clock is mounted in the CPU Unit. The time information will be all zeros in the year 2000 if it is read from Support Software.
 4. When Controller Link Units are used in duplex operation, if there is an active/standby switchover resulting from an error in a Unit, the error log is not inherited from one Controller Link Unit to another. To save the error log, use this command or the Programming Device to read the error log as appropriate.

10-3-2 Error Codes

The following table lists the error codes (in 4-digit hexadecimal) and the contents of the errors.

Error code	Contents	Detail code		Correction	Written to EEPROM	Applicable PLC
		1st byte	2nd byte			
0001 Hex	PLC watchdog timer error	00 Hex	00 Hex	Replace PLC's CPU Unit.	Yes	CV, CS
0002 Hex	PLC service monitor error	Monitor time (unit: ms)		Check operating environment.	Yes	CV, CS

Error code	Contents	Detail code		Correction	Written to EEPROM	Applicable PLC
		1st byte	2nd byte			
0003 Hex	PLC shared RAM error	01 Hex: Cyclic 02 Hex: Event 04 Hex: CPU bus link	00 Hex	Check operating environment.	Yes	CV
0004 Hex	CPU Bus Unit ID number error	00 Hex	00 Hex	Check I/O Connecting Cables.	Yes	CV, CS
0005 Hex	Unit number error	Unit set value	The value recognized by the CPU Unit	Check the Unit number setting. Recreate the I/O table.	Yes	CV
0006 Hex	CPU Unit error	Bit 11: No relevant Unit in I/O table. Bit 12: Hardware test unit number recognized. Bit 13: Incorrect unit number. Bit 14: Duplicated unit number.		Check the Unit number settings. Recreate the I/O table.	Yes	CV, CS
000E Hex	I/O Bus error	00 Hex fixed	00 Hex fixed	Check the operating environment.	Yes	CS
000F Hex	PLC initialization error			Check the operating environment.	Yes	CS
0010 Hex	PLC Setup exceeds capacity			Reduce the number of CPU Bus Units mounted on each CPU Unit by one.	Yes	CS
0011 Hex	PLC initialization error (Time out)			Check the operating environment.	Yes	CS
0012 Hex	CPU Unit memory error	01 Hex: Read error 02 Hex: Write error	01 Hex: Data link table 02 Hex: Network parameters 03 Hex: Routing table 04 Hex: PLC Setup Area	Reset the appropriate data.	Yes	CS
0013 Hex	CPU Unit write-protected			Release the CPU Unit write protect.	Yes	CS

Error code	Contents	Detail code		Correction	Written to EEPROM	Applicable PLC
		1st byte	2nd byte			
0101 Hex	Transmission failed; local node not in Network	Command block Bits 0 to 7: Source node address Bits 8 to 14: Source Network address Bit 15: OFF Response block Bits 0 to 7: Destination node address Bits 8 to 14: Destination Network address Bit 15: ON (1st byte: bits 8 to 15; 2nd byte, bits 0 to 7)		Refer to page 236 <i>Troubleshooting Using Indicators</i> and place the local node into Network.	No	CV, CS
0103 Hex	Transmission failed; retry count exceeded			Using the Controller Link Support Software or FINS commands, run echoback test and check operating environment if errors occur.	No	CV, CS
0104 Hex	Transmission failed; maximum number of frames exceeded.			Reduce the number of events per communications cycle or increase the maximum number of network parameter frames.	No	CV, CS
0105 Hex	Transmission failed; node address incorrect			Refer to <i>4-1 CS-series Optical Ring Controller Link Units</i> or and check node address settings to be sure they are within range and unique.	No	CV, CS
0106 Hex	Transmission failed; redundant node address			Correct node addresses so that they are unique within the same Network.	No	CV, CS
0107 Hex	Transmission failed; destination node not in Network			Refer to <i>10-1 Troubleshooting Using Indicators</i> and place destination node into Network.	No	CV, CS
0108 Hex	Transmission failed; specified Unit does not exist			Refer to <i>4-2 CVM1 and CV-series Optical Ring Controller Link Units</i> and check unit address and unit number of destination.	No	CV, CS

Error code	Contents	Detail code		Correction	Written to EEPROM	Applicable PLC
		1st byte	2nd byte			
0109 Hex	Transmission failed; destination busy	Command block Bits 0 to 7: Source node address Bits 8 to 14: Source Network address Bit 15: OFF Response block Bits 0 to 7: Destination node address Bits 8 to 14: Destination Network address Bit 15: ON (1st byte: bits 8 to 15; 2nd byte, bits 0 to 7)		Increase number of retries or reconfigure system to distribute load.	No	CV, CS
010A Hex	Transmission failed; communications controller error			Conduct an echo-back test and if the effects of noise are considerable, reconsider the operating environment. Restart the Controller Link Unit. If the error occurs again, replace the Unit.	Yes	CV, CS
010B Hex	Transmission failed; PLC error			Refer to the PLC operating manual. If the error occurs again, replace the PLC.	No	CV, CS
010C Hex	Transmission failed; unit number incorrect			Check unit number settings to be sure they are within range and unique.	No	CV, CS
010D Hex	Transmission failed; destination address incorrect			Refer to <i>7-4 Setting Routing Tables</i> , and set a destination address in the routing table.	No	CV, CS
010E Hex	Transmission failed; routing tables not registered			Refer to <i>7-4 Setting Routing Tables</i> , and set a routing table for the source node, destination node, and relay node.	No	CV, CS
010F Hex	Transmission failed; routing table error			Refer to <i>7-4 Setting Routing Tables</i> , and correctly set the routing table.	No	CV, CS
0110 Hex	Transmission failed; too many relay points			Check routing tables and system configuration. Use a CS-series CPU Unit with unit version 2.0 or later and CX-Programmer Ver. 4.0 or later to send commands across three or more network levels.	No	CV, CS
0111 Hex	Transmission failed; command packet too long			Be sure to use the FINS command format.	No	CV, CS
0112 Hex	Transmission failed; header error.			Be sure to use the correct FINS command format.	No	CV, CS
0113 Hex	Transmission failed; I/O setting error	Check I/O table accuracy.	No	CV, CS		
0114 Hex	Transmission failed; CPU bus error	Check Unit and cable connections and clear error.	No	CV, CS		

Error code	Contents	Detail code		Correction	Written to EEPROM	Applicable PLC
		1st byte	2nd byte			
0115 Hex	Transmission failed; redundant I/O allocations	Command block Bits 0 to 7: Source node address		Check unit numbers for redundancy within the same PLC.	No	CV, CS
0116 Hex	Transmission failed; CPU Bus Unit error	Bits 8 to 14: Source Network address		Check Unit and cable connections and clear error.	No	CV, CS
0117 Hex	Internal buffer full	Bit 15: OFF		Increase number of retries or reconfigure system to distribute load.	No	CV, CS
0118 Hex	Illegal packet discarded	Response block Bits 0 to 7: Destination node address Bits 8 to 14: Destination Network address Bit 15: ON (1st byte: bits 8 to 15; 2nd byte, bits 0 to 7)		Check for nodes sending illegal packets.	Yes	CV, CS
0203 Hex	EEPROM error	01 Hex: Read error 02: Hex: Write error	01 Hex: Data link tables 02 Hex: Network parameters 03 Hex: Routing tables	For CVM1 and CV-series PLCs, check that the PLC is not protected. Remake and set the relevant data. If the error occurs again for the CVM1 and CV-series, replace the CPU Unit.	Yes	CV
0206 Hex	Number of participating nodes decreased (local node still participating)	Network parameters maximum node address	Number of non-participating nodes	Check network parameters, node participation, cables, and terminating resistance.	No (See note 4.)	CV, CS
0207 Hex	Number of participating nodes decreased (local node not participating)				No (See note 4.)	CV, CS
0208 Hex	Polling node changed	Address of previous polling node	Address of new polling node	Check previous polling node.	No (See note 4.)	CV, CS
0209 Hex	Inconsistent network parameter	00 Hex	Address of polling node	Using the Controller Link Support Software, check network parameters.	Yes	CV, CS
020C Hex	Time out with token	00 Hex	Error status (See note 3.)	Check network parameters, node participation, cables, and terminating resistance.	No	CV, CS
0210 Hex	Communications controller send error	00 Hex	Error status (See note 3.)	Replace the Controller Link Unit.	Yes	CV, CS
0211 Hex	Duplicate address error	00 Hex	Local node address	Reset so that each node address is used only once within the same Network.	No (See note 4.)	CV, CS
0214 Hex	Node address setting error	Not specified		Check the node address settings and correct them.	Yes	CS

Error code	Contents	Detail code		Correction	Written to EEPROM	Applicable PLC
		1st byte	2nd byte			
0216 Hex	Backup power supply error	00 Hex fixed	Backup power supply error distinction: 01 Hex: OFF to ON 02 Hex: ON to OFF	Check the status of the backup power supply and power supply cables.	No	CV, CS
021A Hex	Set table logic error	00 Hex	01 Hex: Network parameters 02 Hex: Data link tables 03 Hex: Routing tables	Remake and set the appropriate data. Check the unit version code.	Yes	CV, CS
021B Hex	Hardware error	00 Hex: SL1 error 01 Hex: SL2 error	Error status (See note 3.)	Replace the Controller Link Unit.	No (See note 4.)	CV, CS
021C Hex	Data link error inactive	Not set		Restart the Controller Link Unit.	Yes	CV, CS
021E Hex	Network disconnection occurred	Ring status (See note 4.)		Refer to <i>10-5 Locating and Correcting Cable Disconnections</i> for details.	No	CV, CS
0220 Hex	Number of participating nodes decreased (0206 Hex) Additional information #1	Bits 0 to 15 correspond to nodes 1 to 16. The corresponding bit will be ON when that node is disconnected. (Bit 0 is always OFF.)		Check network parameters, the disconnected node, and cables.	No (See note 4.)	CV, CS
0221 Hex	Number of participating nodes decreased (0206 Hex) Additional information #2	Bits 0 to 15 correspond to nodes 17 to 32. The corresponding bit will be ON when that node is disconnected.				CV, CS
0222 Hex	Number of participating nodes decreased (0206 Hex) Additional information #3	Bits 0 to 15 correspond to nodes 33 to 48. The corresponding bit will be ON when that node is disconnected.				CV, CS
0223 Hex	Number of participating nodes decreased (0206 Hex) Additional information #4	Bits 0 to 13 correspond to nodes 49 to 62. The corresponding bit will be ON when that node is disconnected. (Bit 14, 15 is always OFF.)				CV, CS
0230 Hex	Data link stop requested	Start node address	Stop node address	Check the application and Support Software operation if the data link was not intentionally stopped.	Yes	CS
0300 Hex	Packet discarded	Not set		Conduct an echo-back test and find the cause of the error.	No	CV, CS
0601 Hex	Unit error	Not set		Check the operating environment.	Yes	CV, CS

- Note**
1. Applicable PLCs: CV = CVM1 and CV-series PLCs, CS = CS-series PLCs.
 2. Errors indicated by error codes 0101 to 0116 are recorded only when the frame was discarded because transmission was impossible.
 3. Error codes 021E through 0223 are recorded for Optical Ring Controller Link Units/Boards only.
 4. The data is written to EEPROM for the CS1W-CLK13 and CS1W-CLK53.
 5. Error Status:
The status of each bit indicates that an error has occurred as given in the diagram below.
 6. Error code 0230 hex is only recorded for Controller Link Units with unit version 1.2 or later.

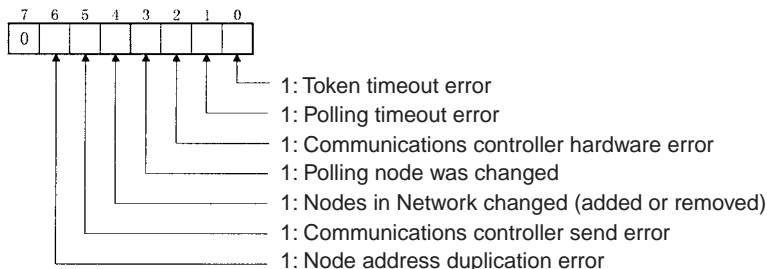

7. Ring Status:
The network disconnection information is indicated as shown in the diagram below.

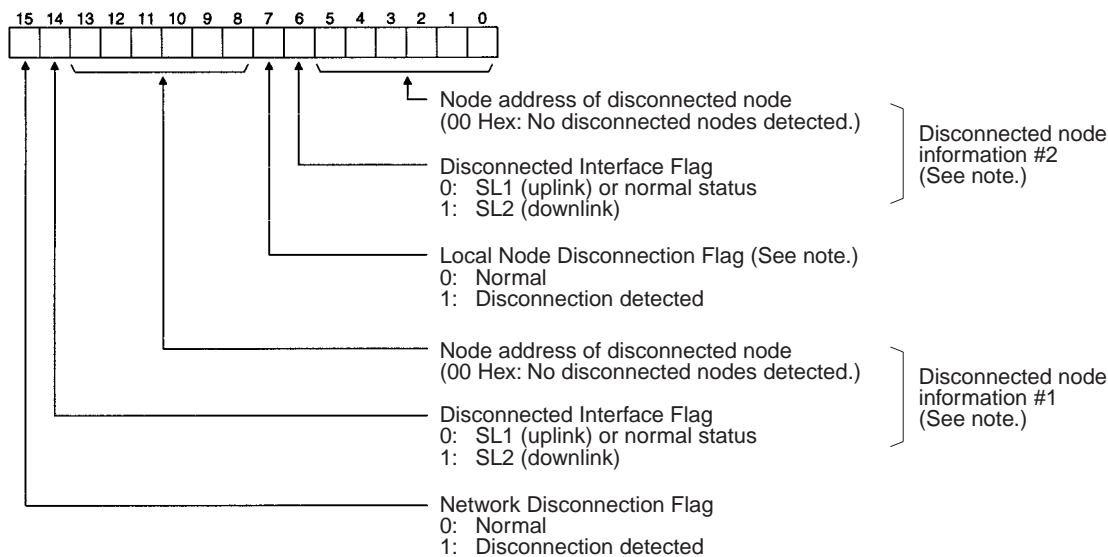

Note The disconnected node information is valid only when bit 15 (the Network Disconnection Flag) is ON. If bit 15 is OFF, the earlier disconnected node information and Local Node Disconnection Flag status is retained.

10-3-3 Reading and Clearing Error Logs

Error logs can be read or cleared using the Controller Link Support Software, the CX-Programmer, PLC Programming Devices, or the message service. The following examples are for the Controller Link Support Software and the message service. When using a PLC Programming Device, refer to the Programming Device’s operation manual for details.

Controller Link Support Software

Read or clear the error log using the following procedure.

- 1,2,3...
1. Display the Main Menu.
 2. Select "E: Error log."
 3. Designated the node. The error log for the designated node will be displayed.
 4. Press the F7 (Clear) Key. The designated node error log will be cleared.

Message Service

Reading an Error Log

Send the ERROR LOG READ FINS command (command code 2102 Hex) to the appropriate node. Refer to 6-5-14 ERROR LOG READ.

Clearing an Error Log

Send the ERROR LOG CLEAR FINS command (command code 2103 Hex) to the appropriate node. Refer to 6-5-15 ERROR LOG CLEAR.

10-4 Troubleshooting Error Messages

This section describes the error messages displayed during data link table checks performed with CX-Net and the required troubleshooting. Perform data link table checks by selecting **Validate Table** from the Table Menu in the CX-Net's Datalink Component Screen, or when transferring data link tables (by selecting **Online - Transfer to PLC**).

Example Display of Error List

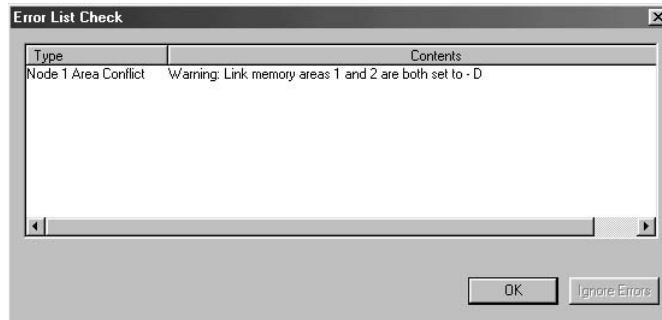

- Note**
- (1) If any errors (except for warnings) are detected during the table check performed when transferring data link tables, the data link tables will not be transferred even if the **OK** Button is clicked. Remove the cause of the error and then transfer the data link tables again.
 - (2) Messages (in the *Contents* field) preceded by "Warning," indicate a warning, not an error that will prevent operation continuing. Check the contents of the message, and confirm that the intended settings and allocations are correct. Click the **OK** Button to transfer the data link tables without any changes.
 - (3) The following two messages indicate warnings for Controller Link Units with unit version 1.2 or later and errors for pre-Ver. 1.2 Controller Link Units.
 Node XX Node size:
 Warning: The total send and receive size of ** exceeds 12000.
 Node XX Area Overlap:
 Warning: Link memory areas 1 and 2 are both set to – [Area]

Error message		Troubleshooting
Node XX Link area exceeded	Total link area 1 Start Address ** size ** is outside max area size	The size ** of Link Area 1 starting from start address ** exceeds the maximum size for the corresponding area. Check the maximum number of words in the corresponding area of the CPU Unit being used, and either change the start address or reduce the number of data link words.
	Total link area 2 Start Address ** size ** is outside max area size	The size ** of Link Area 2 starting from start address ** exceeds the maximum size for the corresponding area. Either change the start address or reduce the number of data link words.
Node XX Dest	Warning: Size outside bounds of Link from node **. Enter value in range ** to **	The number of receive words at the destination node is smaller than the number of send words at the source node. Change the number of send words or number of receive words if the allocations are not intended. If the allocations are intended, the data link tables can be transmitted without making any changes.
	Invalid [Area] offset. Enter value in range ** to **	The value equal to or higher than the number of send words at node XX is set in the number of offset words for the destination node. If the allocation is not intended, change either the number of send words or the number of receive words. If the allocations are intended, the data link tables can be transmitted without making any changes.
Node XX Dest Overflow	Warning: Overflow occurred	The number of receive words at the destination node is larger than the number of send words at the source node. Change the number of send words or number of receive words if the allocations are not intended. If the allocations are intended, the data link tables can be transmitted without making any changes.
	Warning: Block outside bounds of Link from node **. Enter value in range ** to **	The number of receive words at the destination node is smaller than the number of send words at the source node. Change the number of send words or number of receive words if the allocations are not intended. If the allocations are intended, the data link tables can be transmitted without making any changes.
Node XX Node size	Warning: The total node send and receive size of ** exceeds 12000	The total number of send and receive words exceeds 12,000. Controller Link Units with unit version 1.2 or later are required for data links with 20,000 send and receive words. For pre-Ver. 1.2 Controller Link Units, reduce the number of send and receive words.
	Total Node send size of ** exceeds max 20000	The total number of send and receive words exceeds 20,000. Reduce the number of send and receive words to within the maximum.
	Total Node send size of ** exceeds max 8000	The total number of send and receive words exceeds 8,000. Reduce the number of send and receive words to within the maximum.
	Total Node send size of ** exceeds max 62000	The total number of send and receive words exceeds 62,000. Reduce the number of send and receive words to within the maximum. (The 62,000 maximum can be exceeded by personal computer boards only.)
	Total Node send size is 0	The number of allocated words for node ** in node No. xx is 0. Change the number of words or delete the node.
	Total Node send size of ** exceeds max 1000	The total number of send words for node XX exceeds 1,000. Set the number of send words to 1,000 words or less.
	Total Node send size of ** exceeds max 4000	The total number of send words for node XX exceeds 4,000. Set the number of send words to 4,000 or less, or to 1,000 or less. (More than 1,000 send words can be set for the CS1W-CLK13 and CS1W-CLK53.)

Error message		Troubleshooting
Node XX Area Overlap Node XX Area Conflict	Warning: Duplicated area exists in Area 1 and status area	The same words have been allocated for both the Data Link Area 1 and status area. If the duplication is not intended, change the settings for either area. If the duplication is intended, the data link tables can be transmitted without making any changes.
	Warning: Duplicated area exists in Area 2 and status area	The same words have been allocated for both the Data Link Area 2 and status area. If the duplication is not intended, change the settings for either area. If the duplication is intended, the data link tables can be transmitted without making any changes.
	Warning: Link memory areas 1 and 2 are both set to - [Area]	The same area has been set for both Data Link Area 1 and 2. The same area can be set if using Controller Link Units with unit Ver. 1.2 or later. If a pre-Ver. 1.2 Controller Link Unit is being used, set a different area each for Area 1 and Area 2. (This message is displayed for CS-series CPU Units only.)
	Link memory areas 1 and 2 are both set to [Area]	The same area has been set for both Data Link Area 1 and 2. Set a different area each for Area 1 and Area 2. (This message is displayed for CS-series CPU Units only.)
	Link memory areas 1 and 2 are both set to [Area]	The same address has been set for the Data Link Area and the area in which both Area 1 and Area 2 are set. Reset the addresses so that no duplication occurs. (This message is displayed for CS-series CPU Units only.)

The XX symbol refers to the corresponding node address. The two asterisks (**) refer to the corresponding area type, address, and number of words.

10-5 Locating and Correcting Cable Disconnections

In an Optical Ring Controller Link System, the disconnect detection and notification function can be used to locate an open point in the optical ring and notify all of the nodes in the network through the polling node. If the ring is broken at one point, this function allows the system administrator to perform repairs and maintenance before another problem develops or the network stops transmitting data.

10-5-1 Notification of Network Cable Disconnections

Optical Ring Controller Units connect to redundant transmission paths through two interfaces. Data transmitted from another node in the network is received at both of the Unit's connectors (SL1 and SL2) as shown in the following diagram.

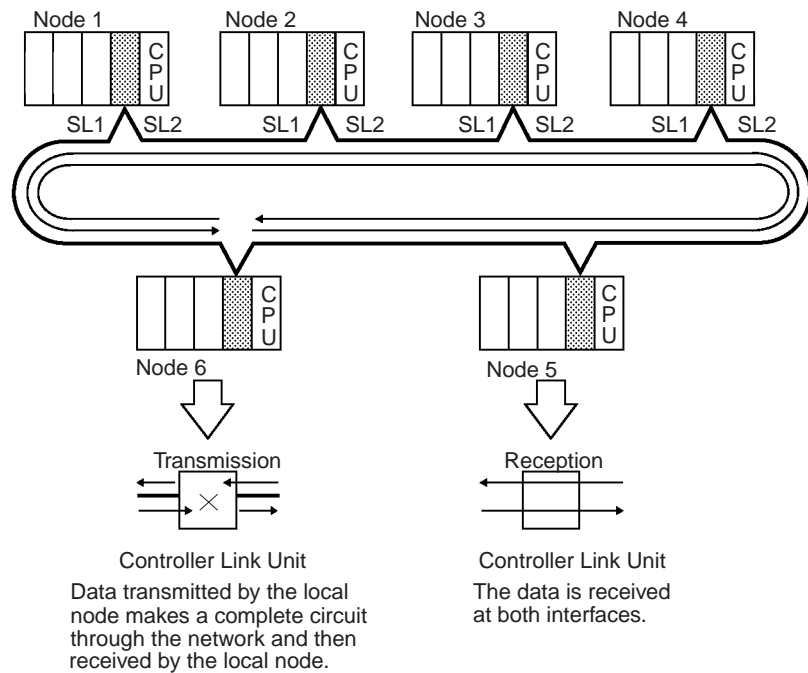

The following diagram shows the same network when the cable between nodes 3 and 4 is disconnected or broken for some reason. Even in this case, network communications will continue normally as long as the Controller Link Unit can receive data normally through either SL1 or SL2.

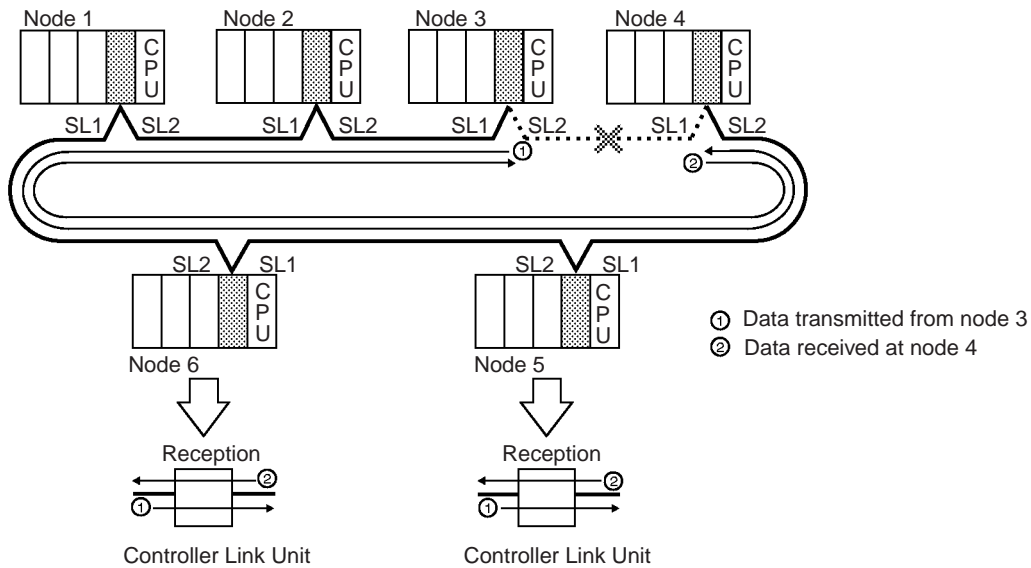

The following diagram shows which interface is used to receive data from the other nodes when the cable between nodes 3 and 4 is disconnected or broken.

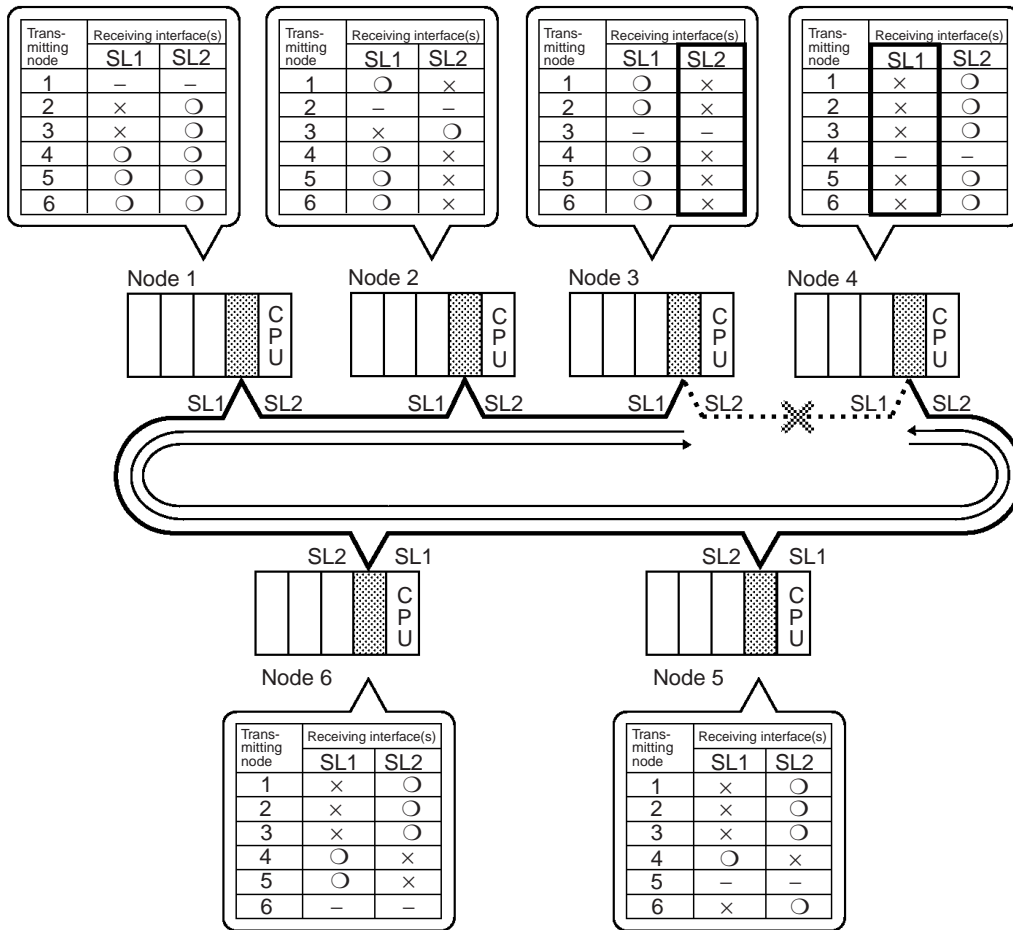

No data is received through node 3's SL2 interface or node 4's SL1 interface. When a node detects that no data is being received through one of its interfaces (such as nodes 3 and 4 in this example), it notifies the polling node that a "network cable disconnection" has occurred.

After receiving notification of a disconnection, the polling node notifies all of the nodes in the network about the disconnection. Each node updates its "ring status" with the disconnection information transmitted from the polling node.

Note When using Controller Link Units in duplex operation, the standby Unit is not recognized as a node. If the backup power supply to the standby Unit is stopped, however, data will not be able to pass through and the network will be disconnected at this point.

Ring Status Information Stored in Each Node

Each node maintains ring status information in one word, as shown in the following diagram.

Ring Status word: CIO 1500 + 25 x (Unit No.) + 23

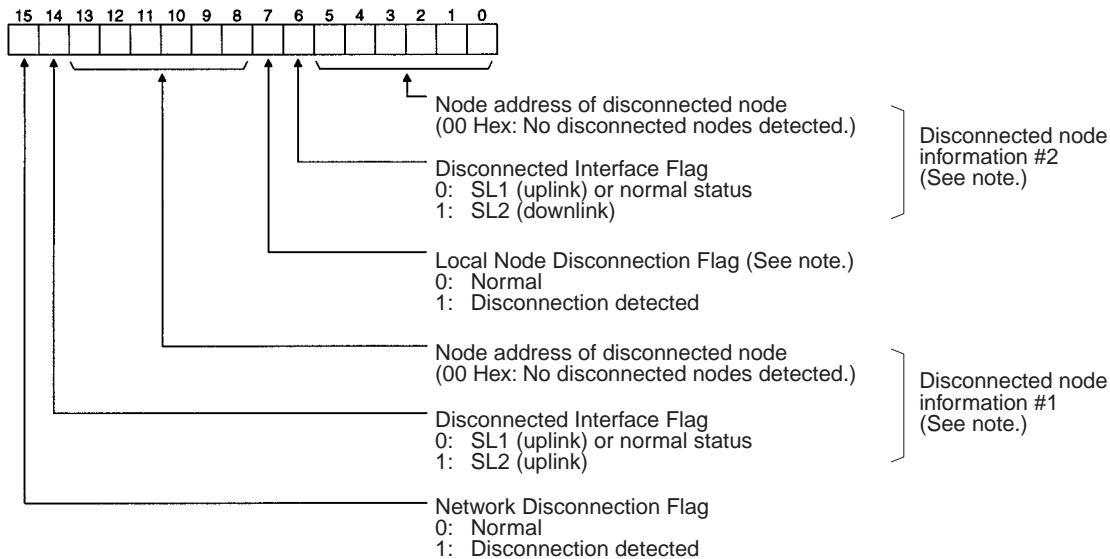

Note The disconnected node information is valid only when bit 15 (the Network Disconnection Flag) is ON. If bit 15 is OFF, the earlier disconnected node information and Local Node Disconnection Flag status is retained.

The following tables show the ring status for each node in the preceding example.

Ring Status of Nodes 3 and 4

Bit	Function	Value
15	Network Disconnection Flag (0: Normal; 1: Disconnection detected)	1
14	Disconnected node information #1	Disconnected Interface Flag 0: SL1/normal; 1: SL2
13 to 8		Node address of disconnected node
7	Local Node Disconnection Flag (0: Normal; 1: Disconnection detected)	1
6	Disconnected node information #2	Disconnected Interface Flag 0: SL1/normal; 1: SL2
5 to 0		Node address of disconnected node

Note The contents of disconnected node information #1 and #2 may be reversed depending on network conditions.

Ring Status of Nodes 1, 2, 5, and 6

Bit	Function	Value
15	Network Disconnection Flag (0: Normal; 1: Disconnection detected)	1
14	Disconnected node information #1	Disconnected Interface Flag 0: SL1/normal; 1: SL2
13 to 8		Node address of disconnected node
7	Local Node Disconnection Flag (0: Normal; 1: Disconnection detected)	0

Bit	Function		Value
6	Disconnected node information #2	Disconnected Interface Flag 0: SL1/normal; 1: SL2	0
5 to 0		Node address of disconnected node	04 Hex

Note The contents of disconnected node information #1 and #2 may be reversed depending on network conditions.

10-5-2 Cable Disconnection Examples

The cables connecting the nodes in an Optical Ring System have two optical fibers which provide communications in both directions. It is possible for just one of the optical fibers to become disconnected.

Example 1: One Optical Fiber Disconnected

The following example shows a network in which just the downlink optical fiber (the uplink fiber for node 4) is broken between nodes 3 and 4.

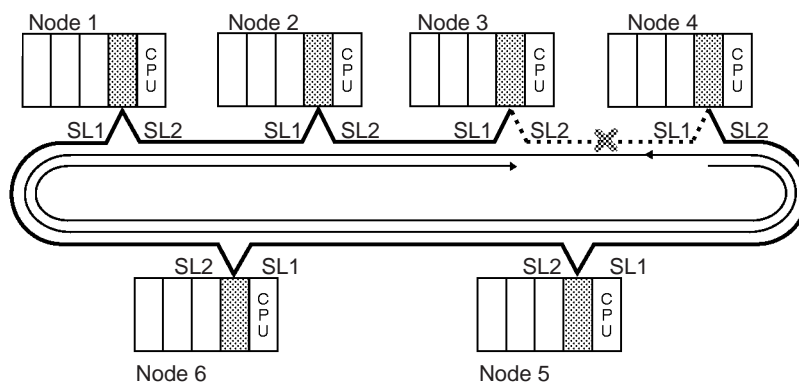

Ring Status Information Stored in Each Node

The following tables show the ring status for each node in the preceding example.

Ring Status of Node 4

Bit	Function		Value
15	Network Disconnection Flag (0: Normal; 1: Disconnection detected)		1
14	Disconnected node information #1	Disconnected Interface Flag 0: SL1/normal; 1: SL2	0
13 to 8		Node address of disconnected node	04 Hex
7	Local Node Disconnection Flag (0: Normal; 1: Disconnection detected)		1
6	Disconnected node information #2	Disconnected Interface Flag 0: SL1/normal; 1: SL2	0
5 to 0		Node address of disconnected node	00 Hex

Note When only one node's disconnected node information is stored, the data is stored in bits 8 to 14 (disconnected node information #1).

Ring Status of Nodes 1, 2, 3, 5, and 6

Bit	Function		Value
15	Network Disconnection Flag (0: Normal; 1: Disconnection detected)		1
14	Disconnected node information #1	Disconnected Interface Flag 0: SL1/normal; 1: SL2	0
13 to 8		Node address of disconnected node	04 Hex
7	Local Node Disconnection Flag (0: Normal; 1: Disconnection detected)		0
6	Disconnected node information #2	Disconnected Interface Flag 0: SL1/normal; 1: SL2	0
5 to 0		Node address of disconnected node	00 Hex

Note When only one node's disconnected node information is stored, the data is stored in bits 8 to 14 (disconnected node information #1).

Example 2: One Optical Fiber Disconnected in Two Places

As long as one of the optical fibers is communicating normally in one direction, the network can continue operating normally even though the other optical fiber is broken in two places. While the system will continue operating normally, repair the ring as soon as possible to prevent the system from going down if another problem occurs.

The following example shows a network in which the downlink optical fiber is broken between nodes 1 and 2 (the uplink fiber for node 2) and the downlink optical fiber is broken between nodes 3 and 4 (the uplink fiber for node 4).

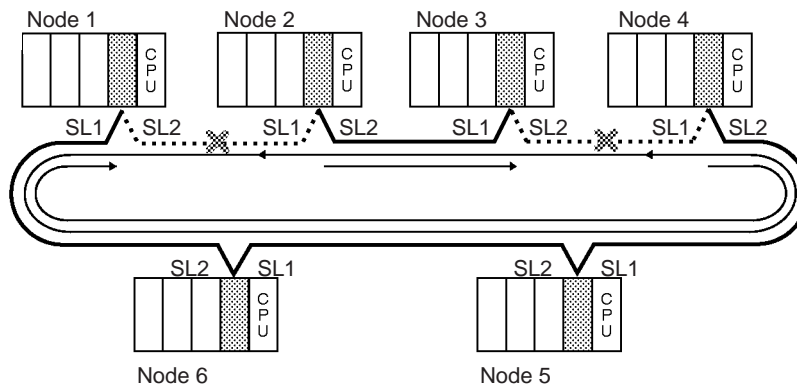

Ring Status Information Stored in Each Node

The following tables show the ring status for each node in the preceding example.

Ring Status of Nodes 2 and 4

Bit	Function		Value
15	Network Disconnection Flag (0: Normal; 1: Disconnection detected)		1
14	Disconnected node information #1	Disconnected Interface Flag 0: SL1/normal; 1: SL2	0
13 to 8		Node address of disconnected node	02 Hex
7	Local Node Disconnection Flag (0: Normal; 1: Disconnection detected)		1
6	Disconnected node information #2	Disconnected Interface Flag 0: SL1/normal; 1: SL2	0
5 to 0		Node address of disconnected node	04 Hex

Note When only one node's disconnected node information is stored, the data is stored in bits 8 to 14 (disconnected node information #1).

Ring Status of Nodes 1, 3, 5, and 6

Bit	Function		Value
15	Network Disconnection Flag (0: Normal; 1: Disconnection detected)		1
14	Disconnected node information #1	Disconnected Interface Flag 0: SL1/normal; 1: SL2	0
13 to 8		Node address of disconnected node	02 Hex
7	Local Node Disconnection Flag (0: Normal; 1: Disconnection detected)		0
6	Disconnected node information #2	Disconnected Interface Flag 0: SL1/normal; 1: SL2	0
5 to 0		Node address of disconnected node	04 Hex

Note When only one node's disconnected node information is stored, the data is stored in bits 8 to 14 (disconnected node information #1).

10-5-3 Correction of Network Cable Disconnections

Cable disconnections must be corrected as soon as possible after they are located with the disconnect detection and notification function.

The following list shows the most likely causes of disconnections based on information gathered for OMRON's earlier Optical Bus Networks.

- 1,2,3...**
1. The power supply is OFF in a node without a backup power supply.
 2. The node's connector is not installed properly.
 3. The cable is faulty. (The end of the cable may be dirty or the cable may be damaged.)
 4. The Controller Link Unit is faulty. (The surface of the receiving element may be dirty or the receiver may be damaged.)

The following table explains how to correct problems with network communications based on the nature of the problems.

Communications conditions	Probable disconnection(s)	Possible remedy
<p>Communications applications can continue operating.</p>	<p>Both optical fibers disconnected at one location</p> <p>One optical fiber disconnected at one location</p>	<ol style="list-style-type: none"> 1. Locate the disconnection point by checking each node's ring status word or connecting to one of the nodes with the support software (CX-Net in CX-Programmer or Controller Link Support Software Ver. 2.00 or later.) 2. Check the power supply and backup power supply at the nodes indicated by the "node address of disconnected node" entries (bits 0 to 5 and bits 8 to 13 of the ring status word.) Correct any problems that are found. 3. Check the optical fiber cables and connectors at the nodes indicated by the "node address of disconnected node" entries (bits 0 to 5 and bits 8 to 13 of the ring status word.) Correct any problems that are found. 4. If the problem is not resolved with steps 2 and 3, it is necessary to plan a system shutdown for maintenance. Shut down the system and replace the following components to remove the component causing the problem: <ul style="list-style-type: none"> • The cable and connectors between the affected nodes • The affected Controller Link Unit(s) (1 or 2 Units)
	<p>One optical fiber disconnected at two locations</p>	<ol style="list-style-type: none"> 1. Locate the disconnection point by checking each node's ring status word or connecting to one of the nodes with the support software (CX-Net in CX-Programmer or Controller Link Support Software Ver. 2.00 or higher.) 2. Check the power supply and backup power supply at the nodes indicated by the "node address of disconnected node" entries (bits 0 to 5 and bits 8 to 13 of the ring status word) and any nodes in between. Correct any problems that are found. 3. Check the optical fiber cable connection at the interface indicated by the Disconnected Interface Flag (bit 6 of the ring status word) for the node indicated in bits 0 to 5. Correct any problems that are found. 4. Check the optical fiber cable connection at the interface indicated by the Disconnected Interface Flag (bit 14 of the ring status word) for the node indicated in bits 8 to 13. Correct any problems that are found. 5. If the problem is not resolved with steps 2 and 3, it is necessary to plan a system shutdown for maintenance. Shut down the system and replace the following components to remove the component causing the problem: <ul style="list-style-type: none"> • The cable and connectors between the affected nodes • The affected Controller Link Unit(s) (1 or 2 Units)
<p>Communications applications cannot continue operating normally</p>	<p>Both optical fibers disconnected at two or more locations</p>	<p>The information reflected in the ring status words may differ from node to node, so the disconnection locations must be corrected in order.</p> <ol style="list-style-type: none"> 1. Locate the disconnection point by checking each node's ring status word or connecting to one of the nodes with the support software (CX-Net in CX-Programmer or Controller Link Support Software Ver. 2.00 or higher.) 2. Check the power supply and backup power supply at the nodes indicated by the "node address of disconnected node" entries (bits 0 to 5 and bits 8 to 13 of the ring status word) and any nodes in between. Correct any problems that are found. 3. Check the optical fiber cables and connectors at the nodes indicated by the "node address of disconnected node" entries (bits 0 to 5 and bits 8 to 13 of the ring status word.) Correct any problems that are found. 4. Repeat steps 1 through 3 until all of the disconnections are corrected. 5. If the problem is not resolved with steps 1 through 4, it is necessary to plan a system shutdown for maintenance. Shut down the system and replace the following components to remove the component causing the problem: <ul style="list-style-type: none"> • The cable and connectors between the affected nodes • The affected Controller Link Unit(s) (1 or 2 Units)

10-5-4 Clearing the Ring Status Words

When a disconnection has been detected, the disconnected node information and Local Node Disconnection Flag status in the ring status words is retained even if the disconnection has been corrected. The data is retained to provide a record of the disconnection if the connection is just unstable and has been restored automatically. (The disconnected node information will be overwritten if another error is detected later.)

The ring status information is recorded independently in each node, so one of the following methods must be used to clear the ring status words.

- Clear the ring status words with the support software (Controller Link Support Software Ver. 2.00 or higher.)
In this case, the ring status must be cleared for each node.
- Send the NETWORK DISCONNECT DATA CLEAR command (FINS command 06 06) from the ladder program or other source. The command must be sent to all of the nodes.

Note If the power supplies (including backup power supplies) to the nodes are not turned ON simultaneously, the temporary disconnection will be detected as the network starts up. When the network is started in token-ring mode, verify that the disconnection has been corrected automatically by checking the ring status words or the status of the RING LED indicators and then clear the ring status words.

The following example shows how to clear the ring status words by sending FINS command 06 06 from the ladder program. In this example, the Controller Link Unit's unit number is 0 and no other Communications Units are mounted in the local node.

Sample Ladder Program for CS-series PLCs

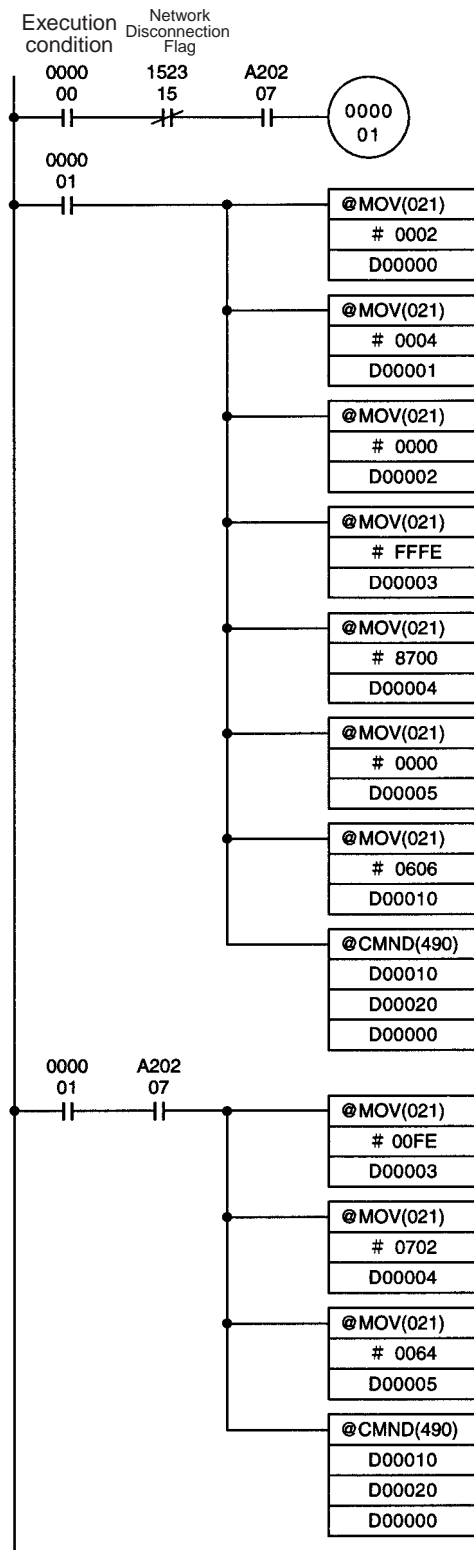

- The ring status clear program will start when the execution condition (CIO 000000) is ON as long as the Network Disconnection Flag (CIO 152315 for unit number 0) is OFF and the Port #7 Enabled Flag (A20207) is ON.

- Sets the control data.

DM word	Contents		Function
D00000	00	02	Number of bytes of command data = 2 bytes
D00001	00	04	Number of bytes of response data = 4 bytes
D00002	00	00	Destination network address = 0 (the local network)
D00003	FF	FE	Destination node address = FF (broadcast to all nodes) Destination unit address = FE (Communications Unit)
D00004	87	00	Response not required, Transmission port number = 7, Number of retries = 0 (Set to 0 for a broadcast.)
D00005	00	00	Response monitoring time = 0 s (Set to 0 for a broadcast.)

- Sets the FINS command code.
06 06 Hex: NETWORK DISCONNECT DATA CLEAR
- Sends the 06 06 FINS command to all Communications Units (except the local node) in the local network.
- Sets the control data.

DM word	Contents		Function
D00000	00	02	Number of bytes of command data = 2 bytes
D00001	00	04	Number of bytes of response data = 4 bytes
D00002	00	00	Destination network address = 0 (the local network)
D00003	00	FE	Destination node address = 00 (local node) Destination unit address = FE (Communications Unit)
D00004	07	02	Response required, Transmission port number = 7, Number of retries = 2
D00005	00	64	Response monitoring time = 10 s

- Sends the 06 06 FINS command to the Communications Unit at the local node in the local network.

- Note**
1. In CS-series PLCs, the Port Enabled Flag for the port being used (A20200 to A20207 correspond to ports 0 to 7) will be turned OFF even if the PROTOCOL MACRO (PMCR) instruction is being executed.
 2. When using the sample program as written above, be sure that the bits and words in the sample program are not already being used by the program or other Special Units.

Sample Ladder Program for CV-series PLCs

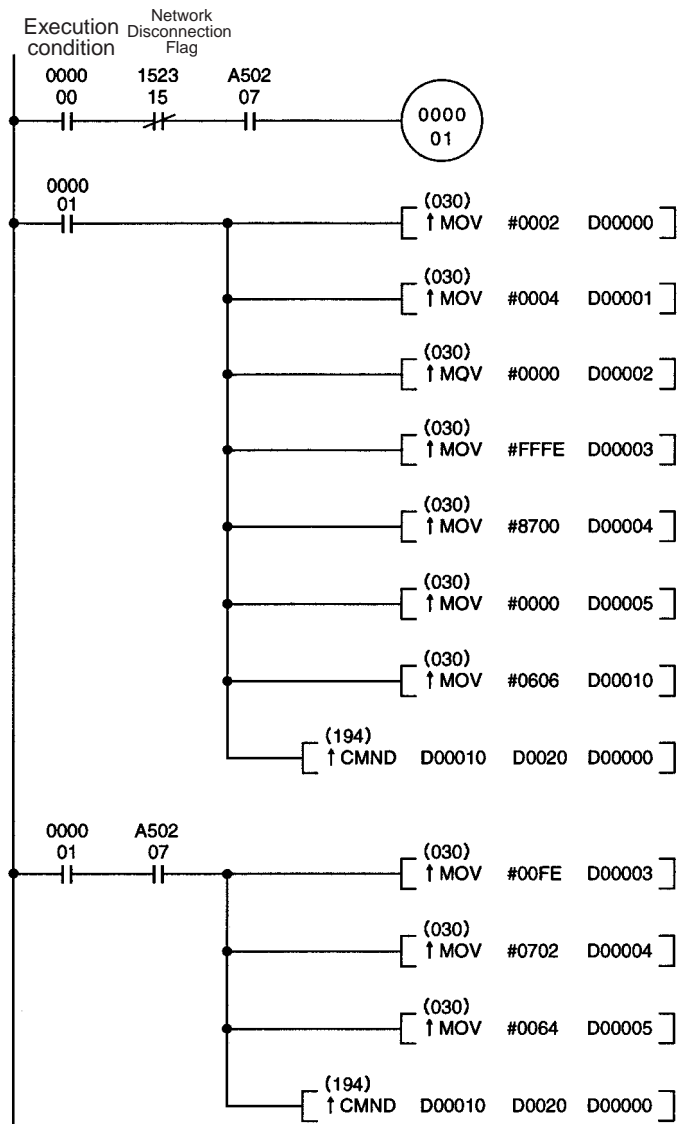

- The ring status clear program will start when the execution condition (CIO 000000) is ON as long as the Network Disconnection Flag (CIO 152315 for unit number 0) is OFF and the Port #7 Enabled Flag (A20207) is ON.
- Sets the control data.

DM word	Contents	Function
D00000	00 02	Number of bytes of command data = 2 bytes
D00001	00 04	Number of bytes of response data = 4 bytes
D00002	00 00	Destination network address = 0 (the local network)
D00003	FF FE	Destination node address = FF (broadcast to all nodes) Destination unit address = FE (Communications Unit)
D00004	87 00	Response not required, Transmission port number = 7, Number of retries = 0 (Set to 0 for a broadcast.)
D00005	00 00	Response monitoring time = 0 s (Set to 0 for a broadcast.)

- Sets the FINS command code.
06 06 Hex: NETWORK DISCONNECT DATA CLEAR

- Sends the 06 06 FINS command to all Communications Units (except the local node) in the local network.
- Sets the control data.

DM word	Contents		Function
D00000	00	02	Number of bytes of command data = 2 bytes
D00001	00	04	Number of bytes of response data = 4 bytes
D00002	00	00	Destination network address = 0 (the local network)
D00003	00	FE	Destination node address = 00 (local node) Destination unit address = FE (Communications Unit)
D00004	07	02	Response required, Transmission port number = 7, Number of retries = 2
D00005	00	64	Response monitoring time = 10 s

- Sends the 06 06 FINS command to the Communications Unit at the local node in the local network.

Note When using the sample program as written above, be sure that the bits and words in the sample program are not already being used by the program or other Special Units.

10-5-5 Reading the Ring Status

It is necessary to know the structure of the ring status word when displaying the word on a Programmable Terminal or other device because several pieces of information are combined in the ring status word. In particular, the “node address of disconnected node” is stored in hexadecimal and mixed with other status flags, so the node addresses must be extracted and converted to decimal.

The sample programs shown below read the two “node address of disconnected node” addresses and store these addresses in the DM area in BCD format. In this example, the Controller Link Unit’s unit number is 0.

Structure of the Ring Status Word

The following diagram shows the structure of the ring status word.

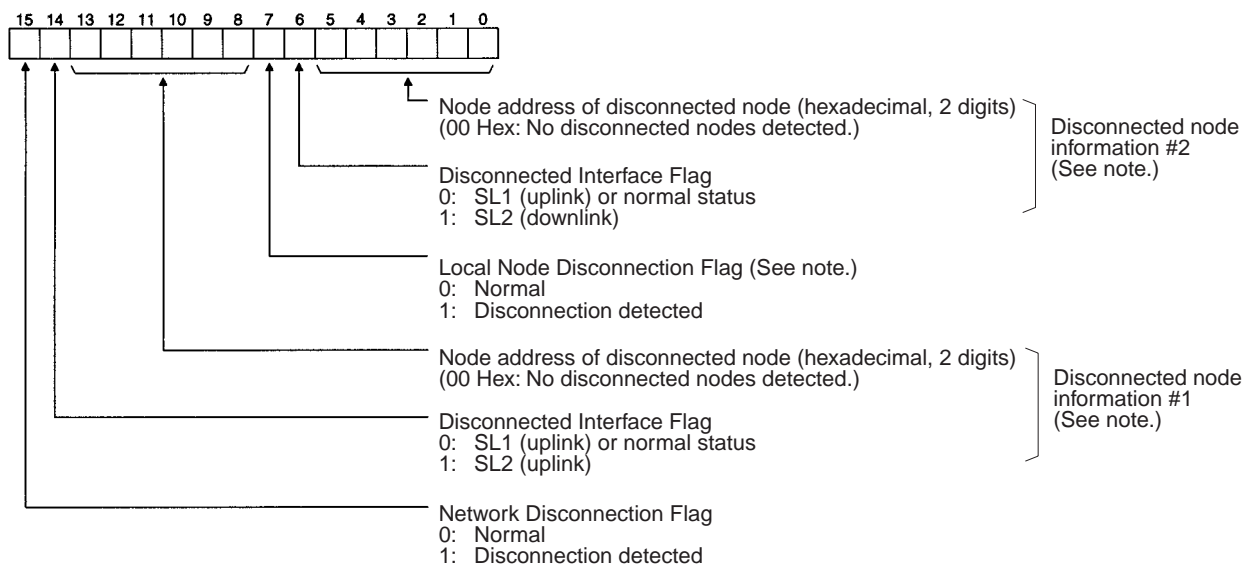

Note The disconnected node information is valid only when bit 15 (the Network Disconnection Flag) is ON. If bit 15 is OFF, the earlier disconnected node information and Local Node Disconnection Flag status is retained.

Sample Program for CS-series PLCs

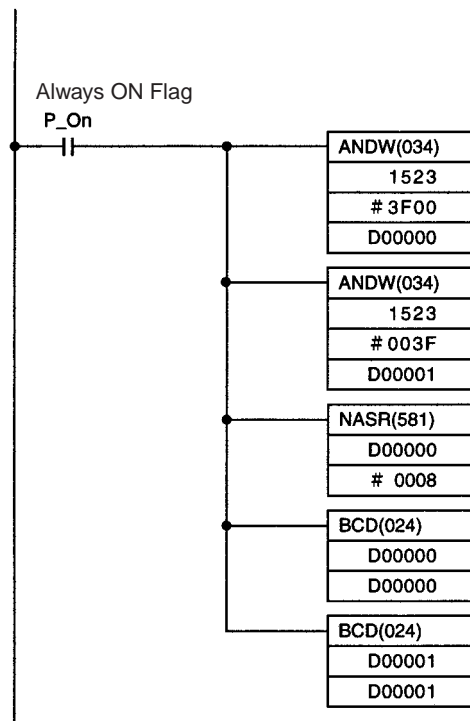

- As long as the Network Disconnection Flag (CIO 152315 for unit number 0) is ON, the “node address of the disconnected node” in bits 8 to 13 is stored in D00000 and the “node address of the disconnected node” in bits 0 to 5 is stored in D00001.
- The contents of D00000 are shifted 8 bits to the right to convert the node address to a proper hexadecimal value.
- The hexadecimal node addresses stored in D00000 and D00001 are converted to BCD.

Note When using the sample program as written above, be sure that the bits and words in the sample program are not already being used by the program or other Special Units.

Sample Program for CV-series PLCs

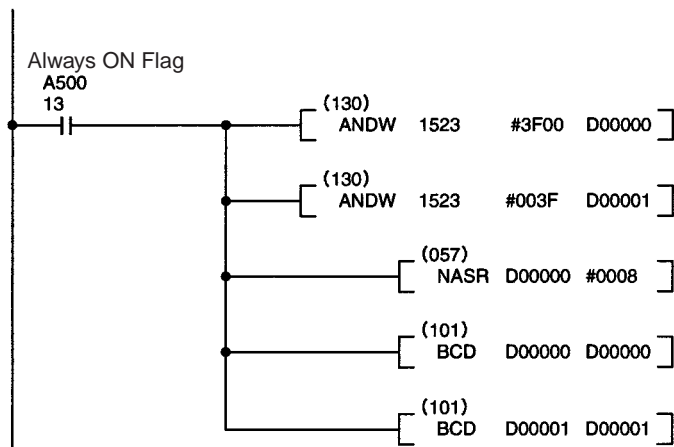

- As long as the Network Disconnection Flag (CIO 152315 for unit number 0) is ON, the “node address of the disconnected node” in bits 8 to 13 is stored in D00000 and the “node address of the disconnected node” in bits 0 to 5 is stored in D00001.
- The contents of D00000 are shifted 8 bits to the right to convert the node address to a proper hexadecimal value.
- The hexadecimal node addresses stored in D00000 and D00001 are converted to BCD.

Note When using the sample program as written above, be sure that the bits and words in the sample program are not already being used by the program or other Special Units.

10-6 Troubleshooting for Duplex Communications Units

Controller Link Units (CS1W-CLK13, CS1W-CLK12-V1, CS1W-CLK53, and CS1W-CLK52-V1) can be used in duplex operation when they are mounted to a CS1D System. When using Controller Link Units in duplex operation, if there is an error in the active Unit, the standby Unit switches to active mode, and communications operations for the node continue. The Unit with the error can also be replaced without turning OFF the power for the CS1D PLC (online replacement).

Note When an error occurs in the active Controller Link Unit and the standby Unit changes to active mode, the node temporarily leaves the network before rejoining it. For details on the time required to complete the switchover, refer to 8-5 *Switching Time for Duplex Units*.

System Configuration Example

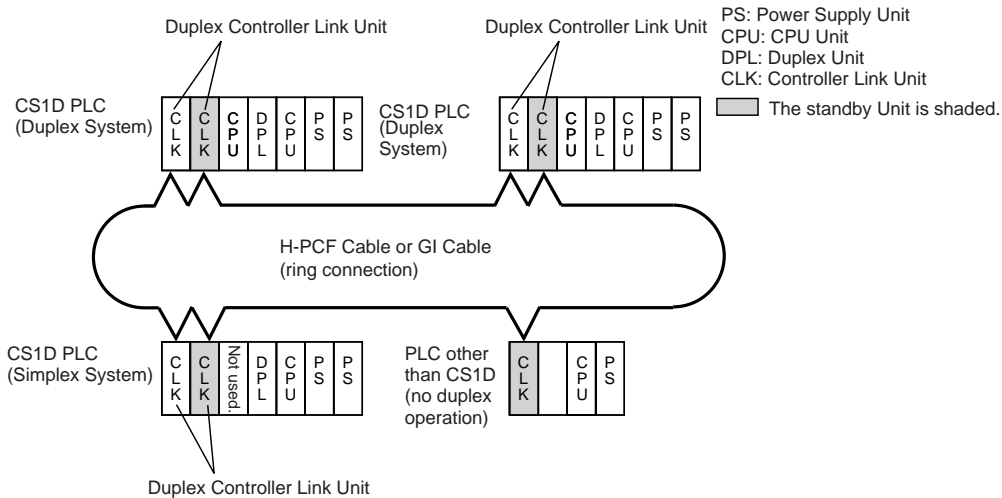

10-6-1 LED Indicators

The LED indicators on the active Controller Link Unit operate in the same way as those for existing Units (i.e., without the “-V1” at the end). Refer to 3-1 *Component Names and Functions*. The operation of the LED indicators on the standby Unit is given below.

CS1W-CLK13
CS1W-CLK12-V1

CS1W-CLK53
CS1W-CLK52-V1

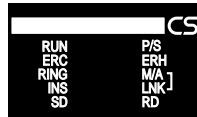

Name	Color	Status	Meaning
RUN (operating)	Green	Lit	Unit operating normally in active mode.
		Flashing	Unit operating normally in standby mode (performing self-diagnosis).
		Not lit	Unit error.
ERC (communications error)	Red	Lit	Error detected by self-diagnosis.
		Not lit	No error detected by self-diagnosis.
P/S (power supply)	Green	Lit	Backup power is being supplied.
		Not lit	Backup power is not being supplied.

- Note**
- The standby Controller Link Unit continuously performs self-diagnostic tests (memory checks and internal loopback tests for communications circuits).
The internal communications circuits are completely separate from the transmission path and so the loopback tests will have no influence on network communications. If an error is detected by self-diagnosis, the ERC indicator will turn ON and the details of the error will be reflected in A437 in the CPU Unit's memory. If this happens, it is probably because of a hardware failure and the Unit must be replaced.
 - The INS, SD, RD, M/A, LNK, and RING LED indicators on Controller Link Units in standby mode do not turn ON.

10-6-2 Troubleshooting for Duplex Systems Using Indicators

This section describes the errors indicated by the indicators on Controller Link Units used in duplex operation in a CS1D System and provides possible remedies.

For details on troubleshooting for errors that have no relation to duplex operation, refer to *10-1 Troubleshooting Using Indicators*.

Troubleshooting for Errors at Startup

Active Unit		Standby Unit		Status area (Auxiliary Area)	Probable cause	Probable remedy
RUN	ERC	RUN	ERC			
Lit	Not lit	Flashing	Not lit	---	Both the active and standby Units are operating normally.	---
Not lit	Not lit	Not lit	Not lit	---	Power is not being supplied correctly to the PLC.	Check the power supply voltage and supply at the recommended voltage.
				---	The Power Supply Unit is not a CS1D Power Supply Unit.	Use CS1D Power Supply Units for CS1D Systems.
				---	The Controller Link Unit has become loose.	Secure the Controller Link Unit firmly.
				CPU Bus Unit Error Flag (A40207)	There were errors in both active and standby Units.	If the same problem occurs when the Units are mounted on another PLC, replace them.
				I/O bus error B: I/O Bus Error Flag (A40114) I/O Bus Error Rack Number (0B Hex is stored in bits 8 to 15 of A404)	The wrong Expansion Backplane is connected.	Replace the Expansion Backplane with a CS1D Expansion Backplane (supports online Unit replacement).
Lit	Not lit	Lit	Not lit	(CPU on standby)	4 or more pairs of Communications Units are set for duplex operation.	The maximum number of pairs of Communications Units mounted on 1 CS1D PLC that can be set for duplex operation is 3.
Not lit	Not lit (ERH is lit)	Flashing	Not lit	Duplex Communications Setting Error Flags (A435) CPU Bus Unit Setting Error Flag (A40203)	The active Controller Link Unit's unit number is set incorrectly.	Set the active Controller Link Unit's unit number to the same number as the standby Unit and reset the power.
					The active Controller Link Unit does not support duplex operation.	Mount a duplex-compatible Controller Link Unit (CS1W-CLK13, CS1W-CLK12-V1, CS1W-CLK53, or CS1W-CLK52-V1).
Lit	Not lit	Not lit	Not lit (ERH is lit)	Duplex Communications Setting Error Flags (A435) CPU Bus Unit Setting Error Flag (A40203)	The standby Controller Link Unit's unit number is set incorrectly.	Set the standby Controller Link Unit's unit number to the same number as the active Unit and reset the power.
Lit	Not lit (ERH is lit)	Not lit	Not lit (ERH is lit)	CPU Bus Unit Duplication Error Flag (A40113)	The duplex settings in the PLC Setup have not been made.	Make the duplex settings for the relevant Unit under <i>Communication Unit Duplex Setting</i> in the PLC Setup using CX-Programmer.
Lit	Not lit (ERH is lit)	Not lit	Not lit	Duplex Communications Setting Error Flags (A435) CPU Bus Unit Setting Error Flag (A40203) CPU Bus Unit Setting Error Flag (A40207)	The active Controller Link Unit does not support duplex operation.	Mount a duplex-compatible Controller Link Unit (CS1W-CLK13, CS1W-CLK12-V1, CS1W-CLK53, or CS1W-CLK52-V1).

Active Unit		Standby Unit		Status area (Auxiliary Area)	Probable cause	Probable remedy
RUN	ERC	RUN	ERC			
Not lit	Not lit	Flashing	Not lit	Duplex Communications Setting Error Flags (A435) CPU Bus Unit Setting Error Flag (A40207)	The was an error in the standby Controller Link Unit.	If the RUN indicator still does not light when the Unit is mounted on another PLC, replace it.
Not lit	Lit	Flashing	Not lit	(CPU standby)	The was an error in the active Controller Link Unit.	If the ERC indicator lights when the Unit is mounted on another PLC, replace it.
					The node address setting for the active Controller Link Unit is out of the allowable range.	Set the node address of the active Unit to the same address as the standby Unit in the range 1 to 62.

Troubleshooting for Errors during Operation

Active Unit		Standby Unit		Status area (Auxiliary Area)	Probable cause	Probable remedy
RUN	ERC	RUN	ERC			
Lit	Not lit	Flashing	Not lit	(No error)	Both the active and standby Units are operating normally.	---
Not lit	Not lit	Lit	Not lit	Duplex Communications Switched Flags (A436)	There was an error in the active Controller Link Unit. (The standby Unit switched to active mode and continued communications.)	Replace the active Controller Link Unit.
Lit	Not lit	Flashing	Lit	Duplex Communications Standby Unit Error Flag (A437)	The was an error in the standby Controller Link Unit. (The active Unit continued communications.)	Replace the standby Controller Link Unit.
Lit	Not lit	Not lit	Not lit	Duplex Communications Standby Unit Error Flag (A437)	The was a watchdog timer error in the standby Controller Link Unit. (The active Unit continued communications.)	Replace the standby Controller Link Unit.

In the CS1D System, online replacement can be performed for Controller Link Units. For details, refer to page 294.

10-7 Cleaning and Inspection

This section describes cleaning and inspection procedures that are to be performed as daily maintenance.

10-7-1 Cleaning

Conduct the following periodic cleaning to keep the Controller Link Unit in optimum condition.

- Wipe the Unit with a dry, soft cloth daily.
- For stains that cannot be removed with a dry cloth, dip the cloth in medium strength alcohol (2%), wring the cloth tightly, and then wipe down the Unit.
- If glue, vinyl, or tape is left on the Unit for long periods of time, it will stain. Remove these items during cleaning.

⚠ Caution Do not use volatile solvents such as benzine or paint thinner, or chemical cloths for cleaning. They will damage the quality of the coating on the Unit.

10-7-2 Inspection

Controller Link Units must be inspected on a regular basis to ensure correct operation. Inspections should be conducted once every 6 to 12 months. If the Unit is subject to extremes in temperature or humidity, inspections should be conducted on a more regular basis.

Tools and Equipment Need for Inspection

The following tools and equipment will be needed to perform inspection and adjustments.

- Assorted flat-blade and Phillips screwdrivers
- Circuit tester or digital voltmeter
- Industrial-grade alcohol and clean cotton cloth
- Synchroscope
- Pen-chart recording oscilloscope
- Thermometer, hygrometer
- Light tester

Inspection Items

Inspect the follow items to see if they deviate from the prescribed standards. If any items do deviate from the standard either adjust so they are within the operating range or adjust the Unit accordingly.

Item	Description	Inspection instrument
Ambient conditions	Temperature: 0° to 55°C	Thermometer
	Humidity: 10% to 90% (no condensation or icing)	Hygrometer
	Dust-free	Visual inspection
Installation	Units securely attached?	Phillips-head screwdriver
	Communications cable connectors secure?	Visual inspection
	Communications cabling damaged?	Visual inspection
Optical fiber deterioration	Has the light attenuation increased? There should be no deterioration since initial installation. • 3.0 dB/km for 50/125 μm cable • 3.5 dB/km for 62.5/125 μm cable	Light tester

10-8 Handling Precautions

The Controller Link Unit is a Network device. If the Unit is damaged, it will effect the entire Network, so always ensure repairs are undertaken immediately. We recommend that you have a spare Controller Link Unit on hand so that repairs may be conducted quickly.

10-8-1 Replacing Existing CS-series Models with New Models

The CS1W-CLK13, CS1W-CLK12-V1, CS1W-CLK53, and CS1W-CLK52-V1 CS-series Controller Link Units are completely compatible upgrades of the CS1W-CLK12 and CS1W-CLK52. The replacement procedure is the same as that for existing models. Also, if the PLC is replaced with a CS1D System, duplex operation of Communications Units and online replacement will be possible.

The maximum number of active and standby Controller Link Units that can be mounted to one network is 62. If all the Units are used in duplex operation, the maximum number of nodes in the network is 31. For details, refer to *Duplex Specifications* on page 203.

10-8-2 Version Upgrade Functions for V1 or Higher Models

For model numbers with suffixes of V1 or higher, earlier models are completely upwardly compatible with the new models. There are restrictions on certain functions, however, in systems where earlier and newer models are used together.

Item	Model number	CS1W-CLK12-V1 CS1W-CLK52-V1	
	CS1W-CLK13 CS1W-CLK53	Unit Ver. 2.0 (See note 1.)	Unit Ver. 1.2 (See note 1.)
Number of send/receive data link words (send or receive data link area that can be created for one PLC node)	20,000 words max.	12,000 words max.	
Number of send words per node (total of area 1 and area 2)	4,000 words max. (See notes 2 and 3.) (optional setting only)	1,000 words max.	
Data link area	The same area can be allocated for area 1 and area 2.	The same area cannot be allocated for area 1 and area 2.	
Maximum number of units that can be mounted to a single PLC	8 Units	4 Units	
Number of error log records	64 records max.	39 records max.	

- Note**
1. For information on checking the unit version, refer to *Unit Versions of CS-series Controller Link Units* on page vi.
 2. When the CS1W-CLK12-V1 and CS1W-CLK52-V1 are used together, no more than 1,000 send words per node can be used.
 3. Use CX-Integrator Data Link Setting Tool version 3.2.1.1 or higher to set data link tables with more than 1,000 send words per node. For information on checking the CX-Integrator Data Link Setting Tool version number, refer to *Checking the CX-Integrator Data Link Setting Tool Version* on page viii.

10-8-3 Replacing the Unit

Observe the following precautions when replacing the Unit.

- Always turn OFF the power before replacing the Unit.
- Check that the new Unit is not faulty.
- If you suspect that a poor connection is the cause of a malfunction, clean the connectors using a clean, soft cloth and industrial-grade alcohol. Remove any lint or threads left from the cloth, and remount the Unit.
- When returning a faulty Unit for repairs, always attach a detailed fault report to the Unit and return to you nearest OMRON outlet as listed at the back of this manual.

Note In order to prevent faulty operation be sure to turn OFF the power to all nodes before replacing the Unit. In an Optical Ring system, it is possible to replace a Unit while the system is operating as long as specific conditions are met.

Refer to *Replacing a Unit while the System is Operating* on page 292 for details. (In a CS1D System, online replacement is possible.)

When replacing the Unit, do not reconnect that node to the Network before carrying out the procedures listed below. In particular, a node with a small address will become the polling node and communicate the initial network parameter status to other nodes, so there is the chance that network parameters in the entire Network will be damaged.

10-8-4 Setting the Unit after Replacement

After replacing a Controller Link Unit, reset the hardware switches, software switches, and data link tables, and wire it in the same manner as the previous Unit. This section describes settings that require particular care. Refer to the Unit replacement methods later in this section for details on replacing the Unit.

Caution After replacing the CPU Unit, transfer important data, such as DM and HR Area contents, to the new CPU Unit before restarting operation. Depending on the program, accidents can occur as a result of incorrect DM or HR Area contents.

CVM1 and CV-series Controller Link Units store data such as data link tables, network parameters, and routing tables in the CPU Unit. When replacing the CPU Unit, reset these settings using the Controller Link Support Software.

Setting the Transmission Format

The following transmission format setting must be made in advance when using a CS1W-CLK13/12/12-V1 Optical Ring Controller Link Unit as a substitute for a CS1W-CLK11 Optical Bus Controller Link Unit. (The CLK53/52/52-V1 Optical Ring Controller Link Units (GI cable) cannot be combined with CLK11/11-V1 Optical Bus Controller Link Units or CLK13/12/12-V1 Optical Ring Controller Link Units (H-PCF cable).)

The control bits for CS-series Controller Link Units are in D30000 + (100 × unit number).

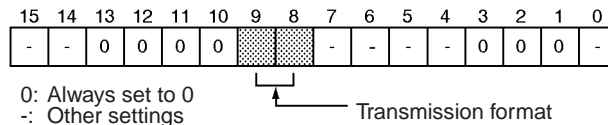

Transmission Path

Bit		Setting
9	8	
0	0	Token-ring mode
0	1	
1	0	
1	1	Token-bus mode

Continuing Operation in Token-bus Mode

1,2,3...

The Optical Bus and Optical Ring Controller Link Units can be used together if you want to keep the system in token-bus mode (daisy-chain connections). Some of the Optical Bus Controller Link Units in the system can be replaced with Optical Ring Controller Link Units that use H-PCF cable.

1. Replace the Unit and turn the power ON without the optical fiber cable connected.
2. Set the transmission format for the replaced Unit to “token-bus mode” with bits 8 and 9 of D30000 + (100 × unit number).
3. Turn the power OFF and then ON again and verify that the Controller Link Unit’s RING indicator is **not** lit. (The Unit is set to token-bus mode if the RING indicator is not lit.)

4. Leave the cable disconnected and set the network parameters. See “Resetting Network Parameters” below for details.
5. Turn the power OFF and install the network cable connector.
6. Check the connections, turn the power ON to all of the nodes, verify that the INS indicators are lit, and verify that the network has started operating normally.

Changing Operation to Token-ring Mode

If all of the Controller Link Units in the network are Optical Ring Controller Link Units (using H-PCF cable), the network can operate in token-ring mode. All of the nodes in the network must be set to token-ring mode.

1,2,3...

1. Replace the Unit and turn the power ON without the optical fiber cable connected.
2. Set the transmission format for the replaced Unit to “token-ring mode” with bits 8 and 9 of D30000 + (100 × unit number).
3. Turn the power OFF and then ON again and verify that the Controller Link Unit’s RING indicator is lit. (The Unit is set to token-ring mode if the RING indicator is lit.)
4. Turn the power OFF and install the optical fiber cable connector. Connect the nodes at the ends of the network to form a ring configuration.
5. Check the connections, turn the power ON to all of the nodes, verify that the INS indicators are lit, and verify that the network has started operating normally.

Resetting Network Parameters

When a CPU Unit has been replaced for a CVM1 or CV-series Controller Link Unit, it is necessary to reset the network parameters, data link tables, and routing tables. This sections describes the resetting procedure for the network parameters. For details on data link table resetting procedures, refer to 5-2 *Setting Data Links* and for routing table resetting procedures, refer to 7-4 *Setting Routing Tables*.

1,2,3...

1. Network parameters are read from the polling node when the Network is activated and this information is distributed to all nodes in the Network. For this reason, temporarily set the replaced node’s polled/polling node setting in the DM parameter area to a “polled node” after replacing the Unit.

CS-series Controller Link Units

DM 30000 + 100 × n
n = Unit number

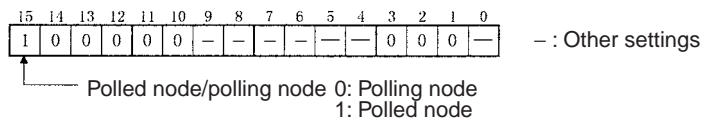

CVM1 and CV-series Controller Link Units

DM 2000 + 100 × n
n = Unit number

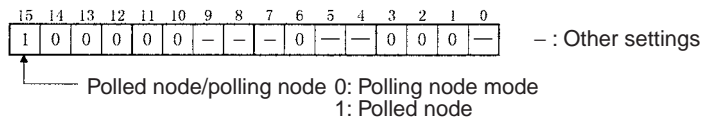

2. Turn the power off once, connect the Controller Link Network and turn the power on again. Check that the Unit is participating in the Network.
If the INS indicator is lit and the ERC and ERH indicators are off, then the Unit is in the Network.
3. Return the polled node/polling node setting of the node in which the Unit was replaced to “polling node.”

CS-series Controller Link Units

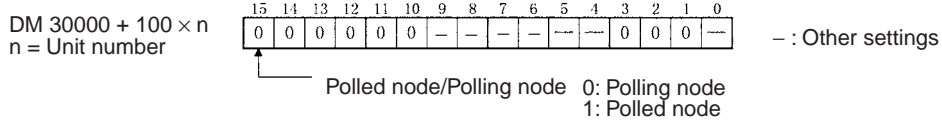

CVM1 and CV-series Controller Link Units

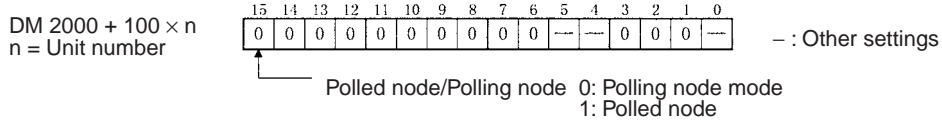

- Restart the Controller Link Unit or turn the power off and then back on again, and then check to see if the Unit is participating in the Network.
If the INS indicator is lit and the ERC and ERH indicators are not lit, then the Unit is in the Network.

Note Restart the Unit only when the data links are halted.

Using the above procedure to reset the network parameters of the node that was replaced to the same as the other nodes in the Network.

Caution When a CPU Unit has been replaced for a CVM1 or CV-series Controller Link Unit, do not connect that node to the Network before carrying out the above procedures. In particular, a node with a small address will become the polling node and communicate the initial network parameter status to other nodes, so there is the chance that network parameters in the entire Network will be damaged.

10-8-5 Replacing the Unit

CS-series, CVM1 and CV-series Controller Link Units

Note CS-series, CVM1 and CV-series Controller Link Unit data is stored in the EEPROM of the CPU Unit. For this reason even if the Controller Link Unit is replaced, on the hardware settings must be made to return all settings to their previous status. If, however, the CPU Unit is replaced, the data link tables and routing tables will need to be reset.

Replacing a Unit after Stopping the System (Normal Replacement)

Typically, the system is shut down as described in the following procedure before replacing a Unit. It is possible to keep the system operating and turn OFF just the node where the Unit is being replaced, but several conditions must be met. Refer to *Replacing a Unit while the System is Operating* below for details.

- 1,2,3...
- Turn OFF all nodes in the Controller Link Network.
 - Detach the communications cables attached to the Controller Link Unit to be replaced and remove the Unit.
 - Mount the new Controller Link Unit in the PLC and connect the communications cables. (Refer to SECTION 3.)
 - Set the unit number, node address, baud rate, and the terminating resistance for the new Unit to the same settings as the previous Unit. (Refer to SECTION 4.)
 - Turn ON the power to the PLCs at all nodes in the Controller Link Network other than those for which the Controller Link Unit was replaced.
 - Check that all the other nodes are active and then turn ON the power to the PLC with the Controller Link Unit that was replaced.

7. Using the Controller Link Support Software, read the network parameters and make sure the Network is operating normally.
8. If the data links are not activated automatically, start the data links from the data link startup node.
9. Check that the data links are operating normally by monitoring them from the Controller Link Support Software.

Replacing a Unit while the System is Operating (Except CS1D Systems)

1,2,3...

If an Optical Ring Controller Link Unit (H-PCF or GI cable) is being replaced, the Unit can be replaced without turning OFF the other nodes in the network as long as the following 3 conditions are met simultaneously. There will be no effect on the network if these conditions are met.

1. The network must be operating in token-ring mode (transmission format setting set to token-ring mode) and there must not be a disconnected node in the network. (See note for the location of the control bit.)
A disconnection can be found by checking the status of the Network Disconnection Flag (bit 15 of the ring status in CIO 1523 + (25 × n)) or monitoring the connection status from the Controller Link Support Software (Ver. 2.00 or later) with the connection configuration information utility.
2. The network must be started with the relevant Controller Link Unit set as a polled node. (See note for the location of the control bit.)
The replaced Controller Link Unit may become a polling node if the polling node/pollled node control bit specifies it as a polling node. In this case, the network parameters may change and the data link may stop. (To restore proper operation, set the network parameters again and restart the data link.)
3. The application program must be written so that the other nodes will not be affected by the removal of the node from the network and its reintroduction.

Note

The transmission format control bits are bits 8 and 9 and the polling node/pollled node control bit is bit 15 in the following word. (The term “n” is the unit number.)

CS-series: DM 30000 + (100 × n)
CVM1 and CV-series: DM 2000 + (100 × n)

If the 3 conditions listed above are met, it is possible to turn OFF just the node being replaced and leave the rest of the system operating. Use the following procedure if the 3 conditions are met.

1,2,3...

1. Turn OFF the backup power supply and the power supply to the PLC containing the Unit that will be replaced.
2. Detach the communications cables and backup power supply cable attached to the Controller Link Unit to be replaced and remove the Unit.
3. Mount the new Controller Link Unit in the PLC and connect just the backup power supply cable. (Leave the backup power supply OFF.)
4. Set the unit number, node address, baud rate, and the terminating resistance for the new Unit to the same settings as the previous Unit. (Refer to SECTION 4.)
5. Turn ON the power to the PLC with the Controller Link Unit that was replaced.
6. Use a Programming Device to turn ON (set to 1) the new Controller Link Unit's polling node/pollled node control bit (bit 15 of the following word). Turning this control bit ON sets the Unit as a polled node.
CS-series: DM 30000 + (100 × n)
CVM1 and CV-series: DM 2000 + (100 × n)
7. Turn OFF the power to the PLC with the Controller Link Unit that was replaced.

8. Connect the communications cables. (Refer to *SECTION 3*.)
9. Turn ON the backup power supply to the Controller Link Unit that was replaced.
10. Turn ON the power to the PLC with the Controller Link Unit that was replaced.
11. Using the Controller Link Support Software, read the network parameters and verify that the Network is operating with the correct settings.
12. If the data links are being used but not activated automatically, start the data links from the data link startup node.
13. Check that the data links are operating normally by monitoring them from the Controller Link Support Software.
14. Use a Programming Device to turn OFF (set to 0) the new Controller Link Unit's polling node/pollled node control bit (bit 15 of the following word). Turning this control bit OFF sets the Unit as a polling node.
 - CS-series: DM 30000 + (100 × n)
 - CVM1 and CV-series: DM 2000 + (100 × n)

Online Replacement in CS1D Systems

In CS1D Systems, if a Controller Link Network is used in token-ring mode, Controller Link Units can be replaced without turning OFF the power for the PLC (online replacement).

- Online replacement is possible only for Controller Link Units (including models without "-V1" at the end) mounted to a CS1D PLC with the transmission path format set to token-ring mode.
- Online replacement is possible in both CS1D Duplex Systems and Simplex Systems.
- In token-ring mode, because of transmission path duplication, Units can be replaced without interrupting communications. In token-bus mode, because there is no transmission path duplication, the network is split during Unit replacement.
- When using Controller Link Units in duplex operation, the standby Unit will switch to active mode during online replacement of the standby Unit. (It will leave the network temporarily before rejoining.) The influence of the node disconnection can be reduced to a minimum. (Refer to *8-5 Switching Time for Duplex Units*.) For Controller Link Units that are not used in duplex operation, the node will remain disconnected from the network throughout online replacement.

Online replacement is performed using a Programming Console (CQM1-PRO01/CQM1H-PRO01/C200H-PRO27).

- Note**
- Online replacement of Controller Link Units will affect the network in the way shown in the following table. Confirm that there will be no adverse effect on the system for the application program before performing online replacement.

Communications Unit operation	Transmission path format	Controller Link operation
Units used in duplex operation	Token-ring mode	<ul style="list-style-type: none"> • During online replacement, the other Unit will switch to active mode and continue communications. (The node will temporarily leave the network before rejoining.) • The transmission path is duplicated and so communications will continue if the cable of the Unit being replaced is disconnected. • If the backup power supply for the Unit being replaced is turned OFF, it is detected as a network disconnection, and the disconnect detection flag for each node turns ON. (The RING indicator for each Controller Link Unit lights.)
	Token-bus mode	Online replacement, with communications continued, is not supported. Turn OFF the power for all the nodes in the network before replacing the Unit. For details, refer to page 292.
Units not used in duplex operation	Token-ring mode	<ul style="list-style-type: none"> • The transmission path is duplicated and so communications will continue if the cable of the Unit being replaced is disconnected. • If the backup power supply for the Unit being replaced is turned OFF, it is detected as a network disconnection, and the disconnect detection flag for each node turns ON. (The RING indicator for each Controller Link Unit lights.)
	Token-bus mode	Online replacement, with communications continued, is not supported. Turn OFF the power for all the nodes in the network before replacing the Unit. For details, refer to page 292.

- In CS1D Systems with Controller Link Units used in duplex operation, set the duplex node as a startup node for data links (Data Link Start/Stop Bit in the CS1D System CPU Unit is turned ON). If the duplex node is not set to be a startup node for data links (Data Link Start/Stop Bit in the CS1D System CPU Unit is OFF), and the relevant node is operating as a polling node, the network's data links may stop if an ACT/STB (active/standby) switchover error occurs.
- Specify the Unit to be replaced using the rack number and slot number. Be sure not to specify the wrong Unit. With reference to the CPU Unit's Operation Manual, confirm the rack number and slot number using the Programming Device before replacing the Unit.

Note Online replacement is not supported by CS1, CS1-H, CVM1, and CV-series CPU Units. Refer to page 292 or page 293.

- 1,2,3...**
1. From the Programming Console's initial display, display the I/O Table Create display.

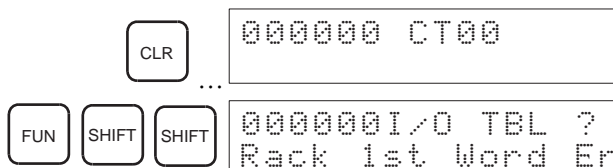

- Specify the rack number and slot number of the Controller Link Unit to be replaced. In this example, the rack number is 0 and the slot number is 3 (unit number 1).

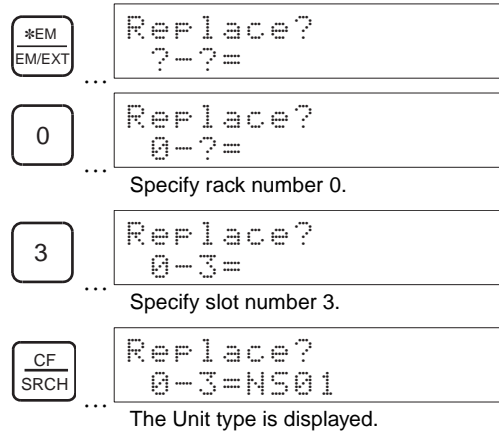

Note When the `CF/SRCH` key is pressed, the type and unit number of the Unit mounted in the specified rack in the specified slot are displayed. For a Controller Link Unit with a unit number of 0, "NS01" is displayed.

- Enable online replacement.

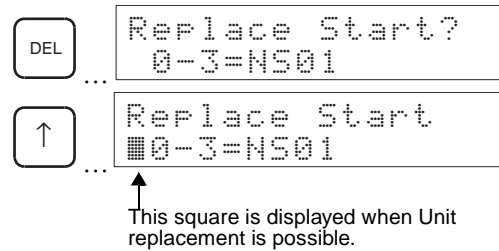

Note Press `INS` `↓` to cancel online replacement.

- Turn OFF the backup power supply for the Controller Link Unit to be replaced.
- Remove the Unit together with its communications cable and backup power supply cable.
- Mount the new Controller Link Unit to the CS1D and connect the backup power supply cable. (Do not turn the backup power supply ON at this stage.)
- Set the unit number and node address for the new Controller Link Unit to the same settings used for the replaced Unit. (Refer to *SECTION 4 Preparations for Communications.*)
- Connect the communications cable. (Refer to *SECTION 3 Installation and Wiring.*)
- Turn ON the backup power supply for the new Unit.
- Indicate that online replacement is finished.
- When not using Communications Units in duplex operation, if data links are used and are not started up automatically, start up the data links using the data link startup node.

12. If data links are restarted in the way described in step 11, confirm that the data links are operating normally using Monitor Data Link Status in the Controller Link Support Software.

SECTION 11

Adding Nodes and Editing Active Data Link Tables

This section describes the methods used to add nodes to the Controller Link Network and change data link tables while the data links are active without turning OFF the power to the PLC in the existing network.

11-1 Adding Nodes in Token-ring Mode	300
11-2 Changing the Data Link Tables with Active Data Links	303

Overview

When Optical Ring Controller Link Units (H-PCF cable or GI cable) are used, token-ring mode can be used and data link tables can be changed while the data links are active, allowing nodes to be added to the network without turning OFF the power to the PLC.

Nodes can be added in token-ring mode by all the Optical Ring Controller Link Units (CS1W-CLK12-V1, CS1W-CLK52-V1, CVM1-CLK12, and CVM1-CLK52).

Changing data link allocations while the system's data links are active is possible only if the nodes whose data link tables are to be changed are CS1W-CLK12-V1 or CS1W-CLK52-V1 Optical Ring Controller Link Units.

- Note**
1. Changing data link tables during active data links is supported by CS1W-CLK12-V1 and CS1W-CLK52-V1 Optical Ring Controller Link Units manufactured after May 2003 (lot number 0306□□_□□□□ onwards) and also by CS1W-SLK13 and CS1W-CLK53.
 2. Use the CX-Net in CX-Programmer version 3.2 or later to change data link tables while the data links are active.

11-1 Adding Nodes in Token-ring Mode

New nodes can be added to the network without turning OFF the PLC if token-ring mode is used with Optical Ring Controller Link Units (H-PCF or GI cable).

Example of Adding Nodes Using Token-ring Mode

System Configuration at Startup

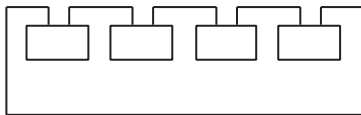

Transmission path format set to token-ring mode in a network without a network disconnection

System Configuration after Adding Nodes

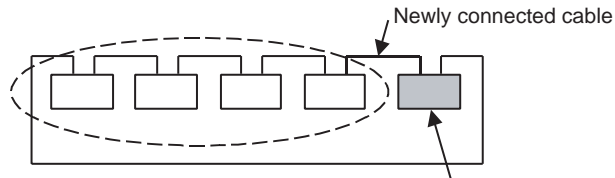

The power to the PLC does not need to be turned OFF to the nodes shown within the broken line. Newly added node

Remove one of the optical cables to add a node to the network. The Controller Link system will detect a line disconnection, but token-ring mode supports transmission path duplication, so the data links and messages communications are not affected.

- Note**
- The following conditions apply when adding new nodes to the Controller Link network without turning OFF the power.

- The network must be operating in token-ring mode and there must not be a disconnected node in the network. Set the transmission path format to token-ring mode using software switches in the DM parameters area (see note a).
A disconnection can be detected by checking to see if the Network Disconnection Flag in bit 15 of the ring status of the CPU Bus Unit is OFF (see note b). Disconnections can also be detected by using the *Controller Link Network Disconnection Information* in the CX-Net in CX-Programmer version 3.0 or later.

- The data link tables must be set correctly for the nodes to be added while the data links are active in the existing network. (The data link tables must be deleted if the added nodes are not participating in the data links.)
- The application program must be written so that the other nodes will not be affected by the line disconnection that is required to add a node to the network or by the transmission of data from the newly added node.
- Check to be sure that the node address for the node to be added is smaller than the maximum node address in the network parameters. If it is larger than the maximum node address, the node will not participate in the network. In that case, use the CX-Integrator change the maximum node address in the network parameter, and then add the node.

Note (a) The transmission format software switches are as follows:

CS-series: $DM\ 30000 + 100 \times \text{unit number}$

CVM1 and CV-series: $DM\ 2000 + 100 \times \text{unit number}$

(b) Ring status: $CIO\ 1523 + 25 \times \text{unit number}$

Procedure for Adding Nodes

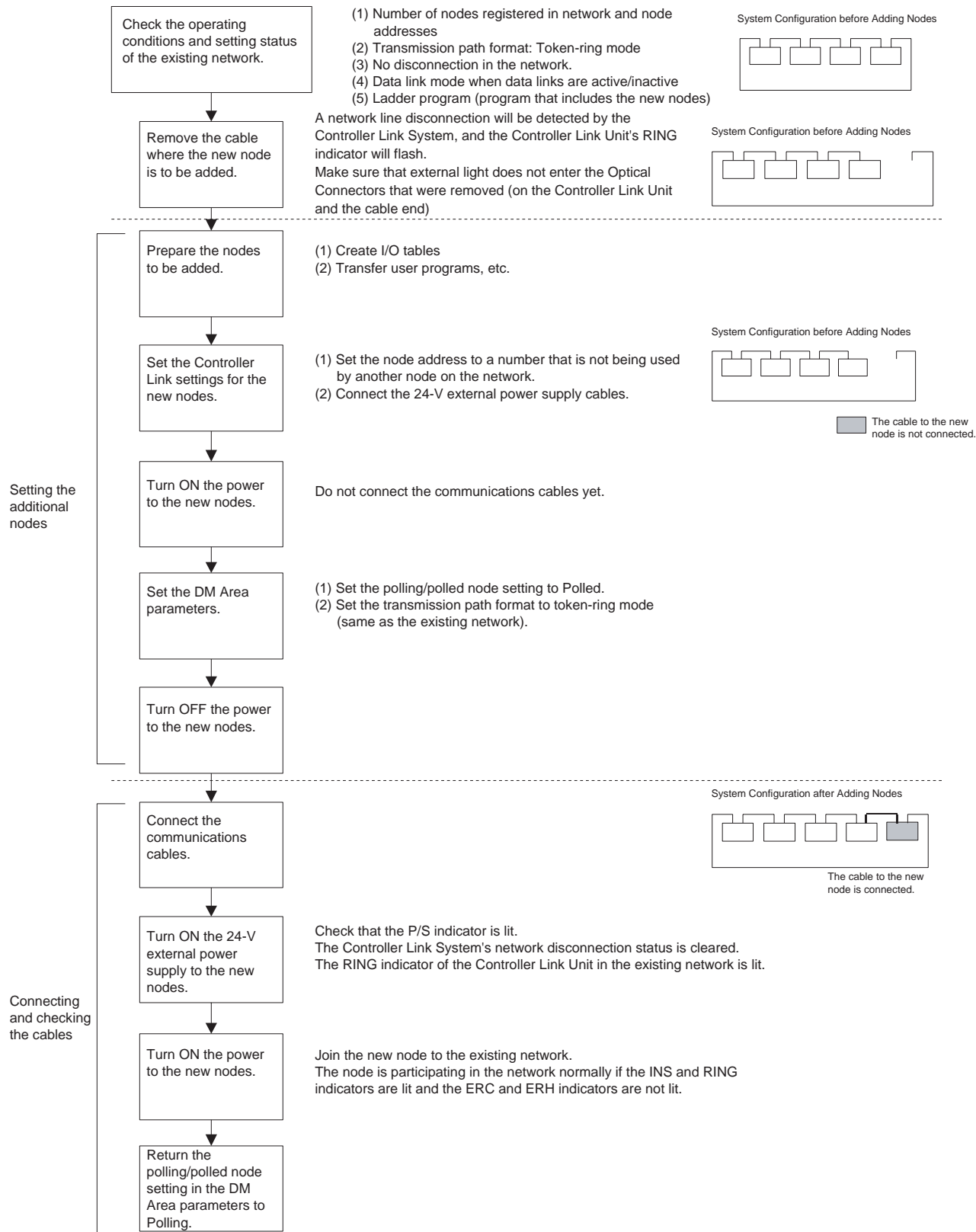

- When data links are active in the existing network, check the following items before adding nodes to the network. If the inappropriate data link tables or parameters are set, the system may not operate properly.

- 1,2,3...**
1. If the new node will participate in user-set data links, make sure that the appropriate data link tables are set in the corresponding nodes.
 2. If the new node will not participate in manually set data links, make sure that the data link tables of the corresponding nodes are deleted.
 3. If automatic settings are used, make sure that the appropriate DM Area parameters have been set.
 - Check that the new data transmission that will be performed due to the new nodes has been considered in the user program for the existing network before adding the nodes. If the ladder program is not suitable, the system may not operate properly.
 - Make sure that the node addresses of the new nodes are not already being used by other nodes in the existing network. If the same node address is used by more than one node, a node duplication error will be detected when the node is added, communications will stop, and the node with the same address will not be able to join the network. Data may also be unexpectedly received from the incorrectly set node. To restore a Controller Link Unit with a duplicated address, reset the node address correctly, then turn ON the power to the corresponding PLCs again, or restart the Controller Link Units.
 - Check to be sure that the node address for the node to be added is smaller than the maximum node address in the network parameters. If it is larger than the maximum node address, the node will not participate in the network. In that case, use the CX-Integrator change the maximum node address in the network parameter, and then add the node.
 - Before connecting the new nodes to the existing network, always set the polling/pollled node setting to *Polled*. If the nodes are connected to the existing network with this setting set to *Polling*, the corresponding node may become the polling node for the network, which will affect the network in the following ways.
- 1,2,3...**
1. When the data link startup switch (software switch in the DM parameters area) of the new node is OFF, all the data links for the whole network including the existing network will be inactive.
 2. When the network parameters being used are different from the default values, the network parameters will return to the default values.

If the data links for the whole network stop, use the Programming Device or software switch in the DM parameters area (data link startup switch) to restart the data links. Return the network parameters to the user settings by resetting with the Programming Device.

 - After the new nodes are participating in the network normally, return the polling/pollled node setting to *Polling*.

11-2 Changing the Data Link Tables with Active Data Links

The data link tables can be changed and data link tables can be allocated for newly added nodes while the system's data links are active if the following Controller Link Units and Support Boards are used.

Models that Support Data Link Table Changes during Active Data Links

Model	Remarks
CS1W-CLK13 CS1W-CLK12-V1	Optical Ring Controller Link Unit (H-PCF Cable) for CS-series PLCs
CS1W-CLK53 CS1W-CLK52-V1	Optical Ring Controller Link Unit (GI Cable) for CS-series PLCs

Model	Remarks
3G8F7-CLK13 3G8F7-CLK12-EV1	Optical Ring Controller Link Support Board (H-PCF Cable) for PCI Bus
3G8F7-CLK53 3G8F7-CLK52-EV1	Optical Ring Controller Link Support Board (GI Cable) for PCI Bus

- Note**
1. When using Controller Link Units and Support Boards that are not listed in the above table, data link tables cannot be changed while data links are active.
 2. Use CS1W-CLK12-V1 and CS1W-CLK52-V1 Controller Link Units from lot number 0306□□_□□□□ or later (manufactured after May 2003). Units from lot number 0305□□_□□□□ and earlier cannot be used to change data link tables with active data links. (The first four digits of the lot number indicate the year and month of manufacture from 2000 onwards.)
 3. CX-Programmer version 3.2 or later must be used to change data link tables with active data links. CX-Programmer version 3.1 or earlier versions cannot be used.

Example of Changing Data Link Table with Active Data Links

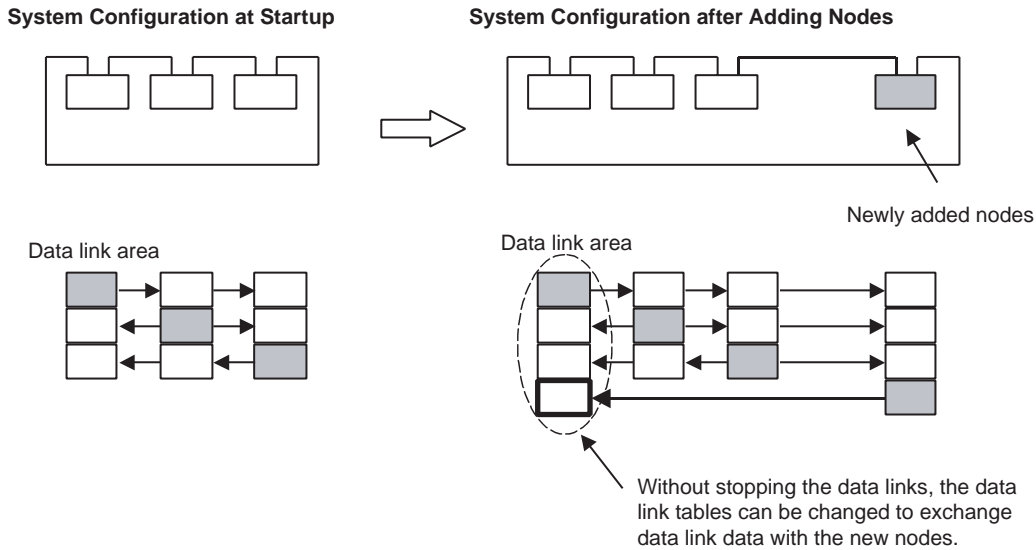

Operations when Changing Data Link Tables

The Controller Link Unit/Support Board that receives the command from the CX-Programmer version 3.2 or later to change a data link table with active data links will temporarily stop refreshing data with the PLC, change to the new data link table (data link refresh allocation) and then resume refreshing data links.

Nodes with data link tables that are changed will send the data from immediately before the tables were changed while PLC data link refreshing is stopped.

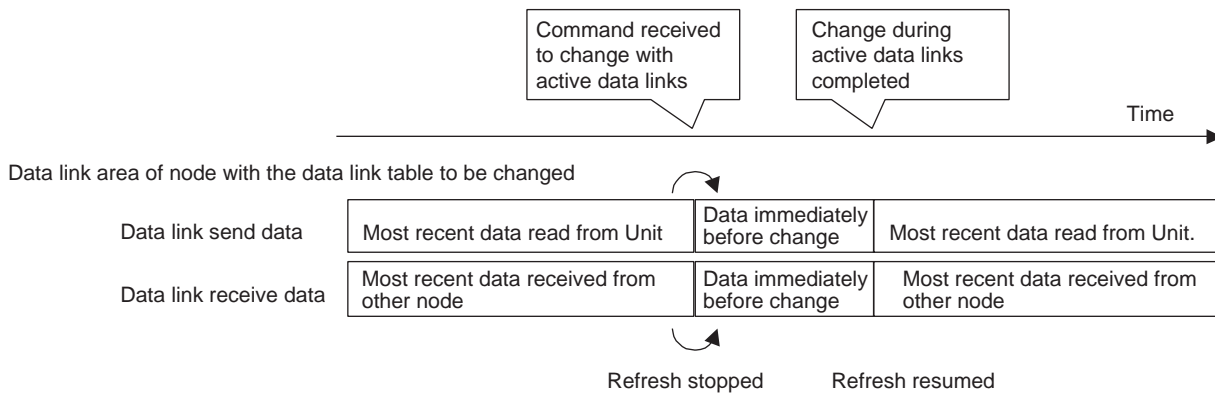

Data link communications will continue, so the Communications Error Flag for the data link status will not turn ON in any of the nodes in the network.

Timing Required to Change Data Link Tables with Active Data Links (Theoretical)

When changing data link tables with active data links, the data refresh for the corresponding node will stop temporarily. During that time, even if the data in the data link send area in the PLC is refreshed, it will not be sent as data link data to other nodes. Data received from other nodes will also not be shown in the data link receive area of nodes with data link tables that are being changed. The data refresh interrupt timing (maximum theoretical value) is as follows:

Data link refresh maximum interrupt time = 2 × Unit cycle time of the node with data link table being changed (See note 1.) + 3 × communications cycle time (ms)

- Note**
1. When CS- or CJ-series PLCs are being used, if the total number of data link send words exceeds 7,800 words, the Unit cycle time is multiplied by 3.
 2. Consider the effect of the data link refresh interrupt time on the applications when changing the data link tables. If the maximum interrupt time is not suitable for the user application, transfer the data link table after stopping the data links from a Programming Device as before, and then restart the data links.

Procedure for Changing the Data Link Tables with CX-Programmer

- Note**
1. Check that the contents of the data link table to be changed will be appropriate for the corresponding node before changing them. If the data link table is set with inappropriate data, the unexpected operation of the system may result in injury.
 2. Check that the effects of the data link table to be changed have been considered in the user programs before changing a data link table.
 3. CX-Programmer version 3.2 or later must be used to change a data link table with active data links. CX-Programmer version 3.1 or earlier versions cannot be used.

The procedure for changing a data link table with active data links is shown here using CX-Programmer version 3.2 and the following system configuration.

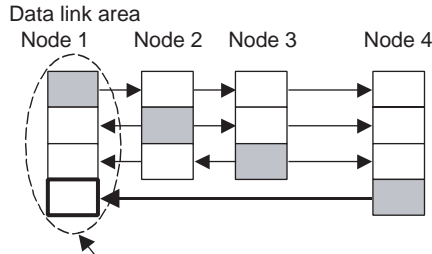
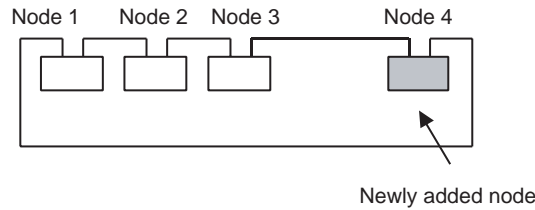

The table contents are as follows:
 Area 1: DM Area
 First word: DM 00000
 Send and receive words: 10 words each

In this example, by adding node 4 to the network, the receive area from node 4 is added to the data link table of node 1.

Procedure

- 1,2,3...**
1. Create the new data link table to be transferred to the node whose data link table is to be changed (node 1) offline.
 2. Save the created data link table in a file.
 3. Connect the personal computer to CX-Net so that it is online.
 4. Select **Data Link – Setup** from the Menu.
 5. Open the data link table file saved in step 1.

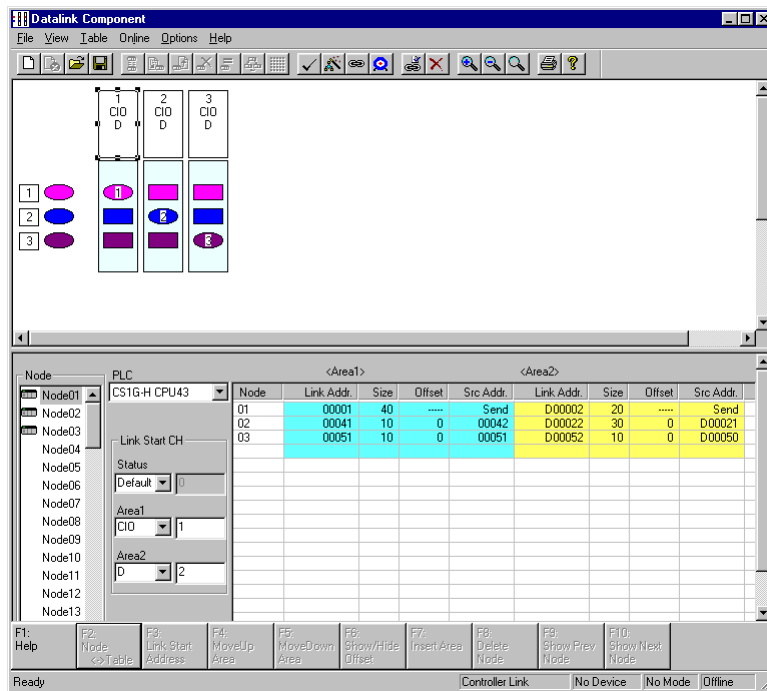

6. Use the mouse to select node 1, whose data link table is to be changed.
7. Select **Online – Transfer to PLC while datalink active** from the Menu.

- The following message box will be displayed. Click the **Yes** Button. If the Yes Button is clicked, the current data link table open in the CX-Net will be compared with the data link table of the node to be changed. If the No Button is clicked, the data link tables will not be compared.

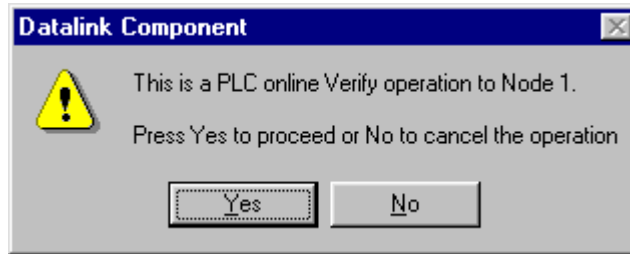

After comparison, if there is any discrepancy, the following message box will be displayed. Click the **OK** Button to check the differences.



The differences between the data link table open on the CX-Net and that of the node to be changed will be displayed.

- Check that the changes are correct, and click the **OK** Button.

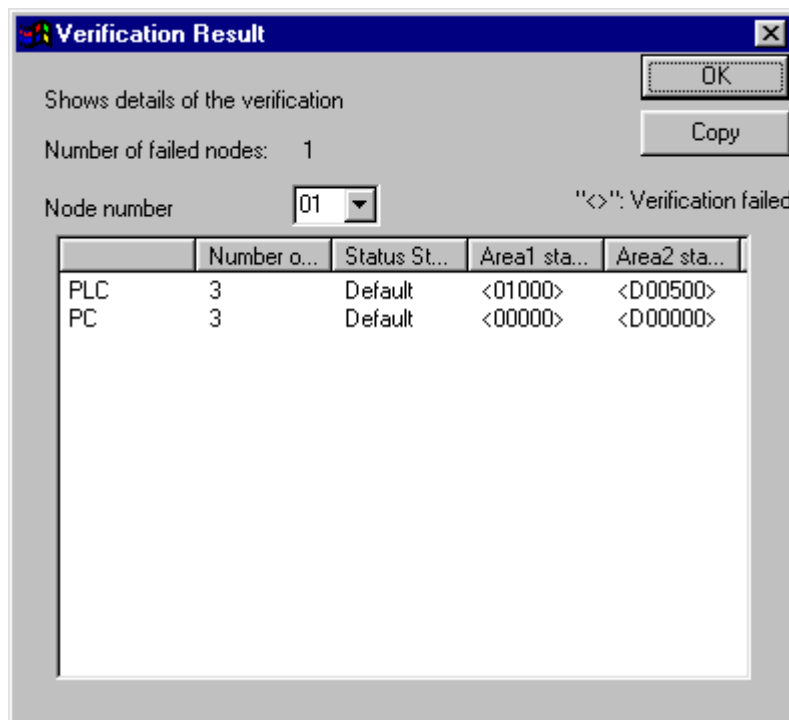

- The message box for confirming data link table transfer will be displayed. Click the **Yes** Button to transfer the data link table. The transfer can be cancelled by clicking the **No** Button. (The active data link table will not be changed if the transfer is cancelled.)

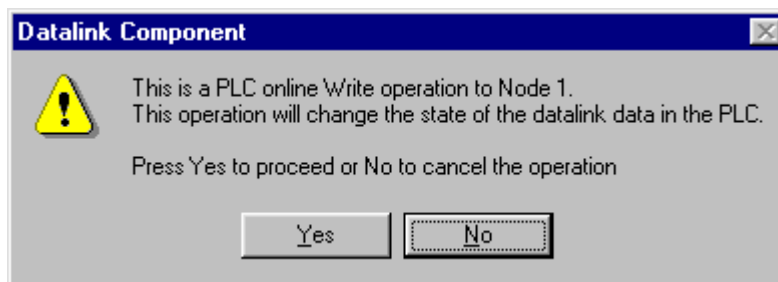

11. When the data link table is written correctly, the following message box will be displayed.



Note Transfer data link tables with active data links for one node at a time. When the *Online – Transfer to PLC while datalink active* field is selected, the following message box will be displayed. Deselect the field and execute the command again.

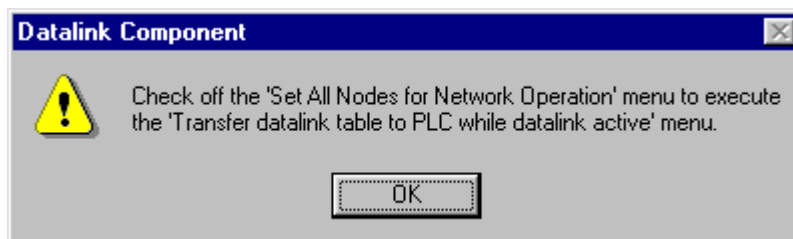

Appendix A

Memory Areas

This appendix provides easy reference to the words in PLC memory areas used by Controller Link Networks.

CS-series PLCs

Auxiliary Area

Word(s)	Bit(s)	Function	
A027 (CS1D System only)	00 to 15	Duplex Communications Unit Operating Flags	
A042 to A049 (CS1D System only)	00 to 15	Duplex Communications Switch Cause Flags	
A202	00 to 07	Communications Port Enabled (Network Communications Enabled) Flags	
A203 to A210	00 to 15	Port #0 to #7 Completion Codes	
A219	00 to 07	Port #0 to #7 Execute Error (Network Communications Execute Error) Flags	
A261 (CS1D System only)	10	Error information for I/O table creation	Online Replacement Flag
	11		Duplex Communications Unit Missing or Non-Duplex Communications Unit Mounted Flag
	12		Duplex Communications Unit Verification Error Flag
A302	00 to 15	CPU Bus Unit Initializing Flags	
A316 (CS1D System only)	03	Duplex Communications Error Flag	
A401	13	Duplicate Number Error Flag (fatal error)	
A402	03	CPU Bus Unit Setting Error Flag	
	07	CPU Bus Unit Error Flag	
A410	00 to 15	CPU Bus Unit Duplicate Number	
A417	00 to 15	CPU Bus Unit Error, Unit Number Flags	
A427	00 to 15	CPU Bus Unit Setting Error Unit Number	
A434 (CS1D System only)	00 to 15	Duplex Communications Error Recognition Flags	
A435 (CS1D System only)	00 to 15	Duplex Communications Setting Error Flags	
A436 (CS1D System only)	00 to 15	Duplex Communications Switched Flags (non-fatal communications error)	
A437 (CS1D System only)	00 to 15	Duplex Communications Standby Unit Error Flags (non-fatal communications error)	
A501	00 to 15	CPU Bus Unit Restart Bits	

Duplex Communications Unit Operating Flags

Bits A02700 through A02715 are turned ON when the corresponding Communications Unit (Units #0 through #15, respectively) is operating normally in duplex operation.

Duplex Communications Switch Cause Flags

When an error occurs in the active Communications Unit with the corresponding unit number (see note) and operation is switched to the standby Communications Unit, an error code will be stored to show the cause of the error in the active Communications Unit. The corresponding bit in A436 (Duplex Communications Switched Flags) will also turn ON.

Note Duplex Communications Switch Cause Flags (A042 to A049)

	15	8 7	0	
A042	Unit number 1	Unit number 0		The following error codes are written to the corresponding area for each unit number. 01 Hex: EEPROM error 02 Hex: Error in the communications controller's transmitter 03 Hex: Hardware error in the communications controller 80 Hex: Watchdog timer error
A043	Unit number 3	Unit number 2		
A044	Unit number 5	Unit number 4		
A045	Unit number 7	Unit number 6		
A046	Unit number 9	Unit number 8		
A047	Unit number 11	Unit number 10		
A048	Unit number 13	Unit number 12		
A049	Unit number 15	Unit number 14		

Network Status Flags

Bits A20200 through A20207 are turned ON to indicate that ports #0 through #7, respectively, are enabled for the SEND(90), RECV(98), CMND(490) and PMCR. Bits A219200 through A219207 are turned ON to indicate that an error has occurred in ports #0 through #7, respectively, during data communications using SEND(90), RECV(98), CMND(490), or PMCR. Refer to page 154

A203 through A210 contain the completion codes for ports #0 through #7, respectively, following data communications using SEND(90), RECV(98), CMND(490), or PMCR. Refer to page 154.

Online Replacement Flag

Bit A26110 turns ON when a Basic I/O Unit, Special I/O Unit, or CPU Bus Unit is being replaced online on the CPU Rack, an Expansion Rack, or a Long-distance Expansion Rack. If an attempt is made to generate the I/O tables while this flag is ON, an I/O table generation error will occur and the I/O tables will not be created. The bit turns OFF when the status is normal.

Duplex Communications Unit Missing or Non-Duplex Communications Unit Mounted Flag

Bit A26111 turns ON when Duplex Units are not mounted for a unit number specified for Duplex Communications Units (i.e., a Unit is missing or the mounted Units do not support duplex operation). If an attempt is made to generate the I/O tables while this flag is ON, an I/O table generation error will occur and the I/O tables will not be created. The bit turns OFF when the status is normal. The corresponding bit in A434 will also turn ON.

Duplex Communications Unit Verification Error Flag

Bit A26112 turns ON when the unit number or node address of 2 Units specified as a pair of Duplex Communications Units in the PLC Setup does not agree. If an attempt is made to generate the I/O tables while this flag is ON, an I/O table generation error will occur and the I/O tables will not be created. The bit turns OFF when the status is normal. The corresponding bit in A435 will also turn ON.

CPU Bus Unit Initializing Flags

Bits A30200 through A30215 turn ON while the corresponding CPU Bus Units (Units #0 through #15, respectively) are initializing.

Duplex Communications Error Flags

Bit A31603 turns ON when there is an error in a Duplex Communications Unit (either active or standby). This flag can be used to check whether or not there are errors in any Duplex Communications Units. This flag will turn ON if any of the flags below turn ON.

A43600 to A43615: Duplex Communications Switched Flags

A43700 to A43715: Duplex Communications Standby Unit Error Flags

CPU Bus Unit Setting Error Flag and Unit Number

Bit A40203 is turned ON when the CPU Bus Units actually installed differ from the Units registered in the I/O table. The unit number of the CPU Bus Unit involved is written to word A427.

Bits A42700 through A42715 correspond to CPU Bus Units #0 through #15, respectively. When a error occurs, the bit corresponding to the unit number of the CPU Bus Unit involved is turned ON.

CPU Bus Unit Error Flag

Bit A40207 is turned ON when a parity error occurs during the transmission of data between the CPU Unit and CPU Bus Units. The unit number of the CPU Bus Unit involved is written to word A417.

CPU Bus Unit Numbers

Bits A41000 through A41015 correspond to CPU Bus Units #0 through #15, respectively. When two CPU Bus Units have the same unit number, the bits corresponding to the unit numbers of the CPU Bus Units involved are turned ON.

CPU Bus Unit Duplication Error Flag

Bit A40113 is turned ON when two CPU Bus Units have been assigned the same unit number. The duplicated unit number is indicated in A410.

CPU Bus Unit Error, Unit Number Flags

When an error occurs in a data exchange between the CPU Unit and an CPU Bus Unit, the CPU Bus Unit Error Flag (A40207) is turned ON and the bit in A417 corresponding to the unit number of the Unit where the error occurred is turned ON.

Duplex Communications Error Recognition Flags

Bits A43400 through A43415 turn ON when a Duplex Unit is not mounted for a unit number specified for Duplex Communications Units (i.e., a Unit is missing or the mounted Unit does not support duplex operation). Bits 00 to 15 correspond to unit numbers 0 to F.

Duplex Communications Setting Error Flags

Bits A43500 through A43515 turn ON when the unit number or node address of 2 Units specified as a pair of Duplex Communications Units in the PLC Setup does not agree. Bits 00 to 15 correspond to unit numbers 0 to F.

Duplex Communications Switched Flags

Bits A43600 through A43615 turn ON when an error occurs in the active Communications Unit and operation is switched to the standby Communications Unit. Communications will be continued by the standby Communications Unit. Bits 00 to 15 correspond to unit numbers 0 to F. The bit is turned OFF when online replacement is performed for the faulty Communications Unit. A code indicating the cause of the switch is stored in A042 to A049.

Duplex Communications Standby Unit Error Flags

Turns ON when an error occurs in the standby Communications Unit (from self-diagnosis). Communications will be continued by the active Communications Unit. Bits 00 to 15 correspond to unit numbers 0 to F. The bit is turned OFF when online replacement is performed for the faulty Communications Unit.

CPU Bus Unit Restart Bits

Bits A50100 through A50115 can be turned ON to reset CPU Bus Units number #0 through #15, respectively. The Restart Bits are turned OFF automatically when restarting is completed.

CIO Area: CPU Bus Unit Area

The CPU Bus Unit Area (CIO Area) is allocated to CPU Bus Units according to the unit numbers assigned to them, as shown below. Each Unit is allocated 25 words.

Unit no.	Words	Unit no.	Words
0	1500 to 1524	8	1700 to 1724
1	1525 to 1549	9	1725 to 1749
2	1550 to 1574	10	1750 to 1774
3	1575 to 1599	11	1775 to 1799
4	1600 to 1624	12	1800 to 1824
5	1625 to 1649	13	1825 to 1849
6	1650 to 1674	14	1850 to 1874
7	1675 to 1699	15	1875 to 1899

Error Information: CIO 1500 + 25 x (Unit No.) (See page 254)

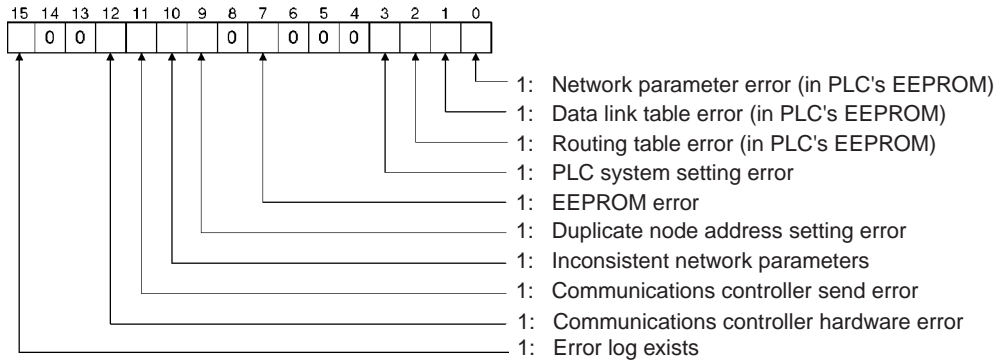

Polling Node Address, Startup Node Address: CIO 1500 + 25 x (Unit No.) + 1 (See page 254)

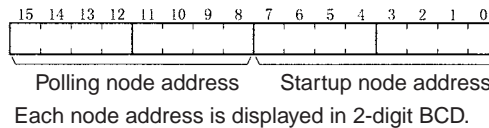

Network Participation Status: CIO 1500 + 25 x (Unit No.) + 2 to +5 (See pages 155, 255)

	15	14	13	12	11	10	9	8	7	6	5	4	3	2	1	0
+2CH	16	15	14	13	12	11	10	9	8	7	6	5	4	3	2	1
+3CH	32	31	30	29	28	27	26	25	24	23	22	21	20	19	18	17
+4CH	48	47	46	45	44	43	42	41	40	39	38	37	36	35	34	33
+5CH	—	—	62	61	60	59	58	57	56	55	54	53	52	51	50	49

The numbers in the squares indicate node addresses.
 The corresponding node participation status is as follows:
 0: Not participating in the network
 1: Participating in the network

Note If the local node is not participating in the network, the status for the local node will be 0 (not participating), and the status for the other nodes will be indefinite.

Local Data Link Participation Status: CIO 1500 + 25 x (Unit No.) + 6 (See page 255.)

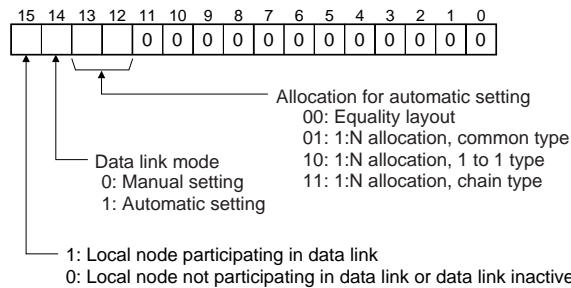

Data Link Status: CIO 1500 + 25 x (Unit No.) + 7 to + 22 (See pages 130, 255.)

When the first data link status word for manually set data link tables or for automatically set data links is not set or is set to 0, the data link status is stored in the words shown below.

When 8-bit Format is Specified

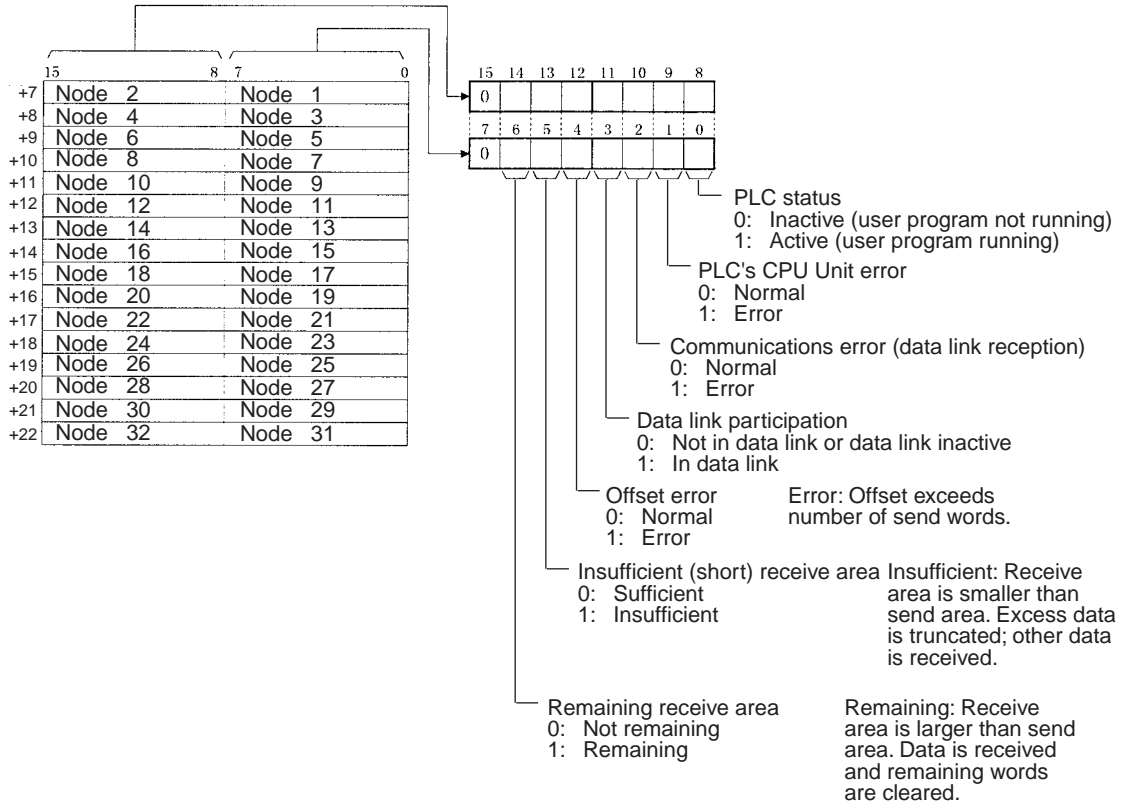

When 4-bit Format is Specified

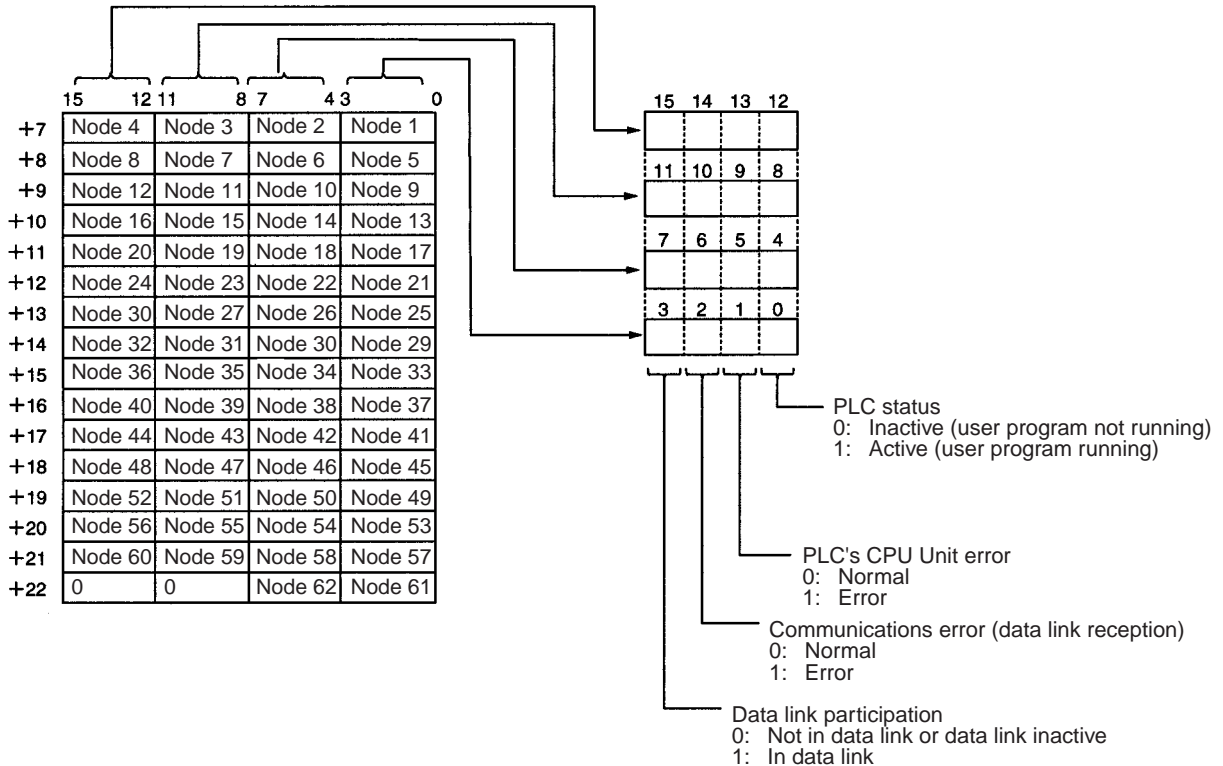

Note Refer to 5-4 Checking Data Link Status for details on status flags.

Ring Status: CIO 1500 + 25 x (Unit No.) + 23

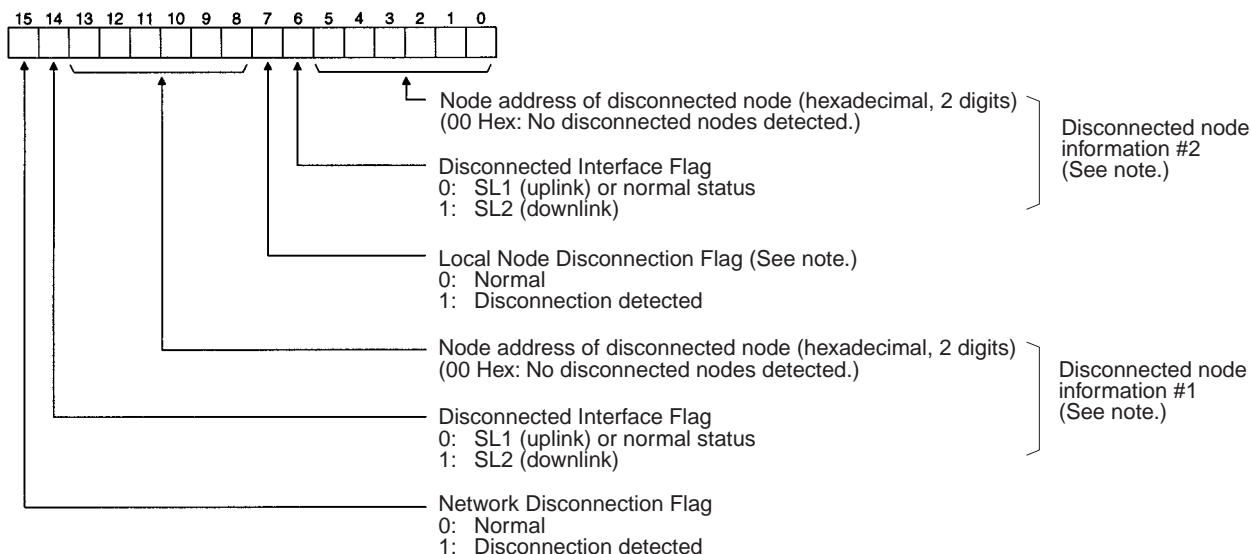

Note The disconnected node information is valid only when bit 15 (the Network Disconnection Flag) is ON. If bit 15 is OFF, the earlier disconnected node information and Local Node Disconnection Flag status is retained.

Power Status: CIO 1500 + 25 x (Unit No.) + 24

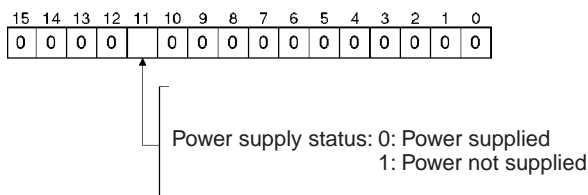

DM Area: CPU Bus Unit Area

The CPU Bus Unit Area (data memory) is allocated to CPU Bus Units according to the unit numbers assigned to them, as shown below. Each Unit is allocated 100 words, of which 12 words are used. In the Controller Link Unit this area is called the DM Area.

Unit no.	Words	Unit no.	Words
0	DM30000 to DM30011	8	DM30800 to DM30811
1	DM30100 to DM30111	9	DM30900 to DM30911
2	DM30200 to DM30211	10	DM31000 to DM31011
3	DM30300 to DM30311	11	DM31100 to DM31111
4	DM30400 to DM30411	12	DM31200 to DM31211
5	DM30500 to DM30511	13	DM31300 to DM31311
6	DM30600 to DM30611	14	DM31400 to DM31411
7	DM30700 to DM30711	15	DM31500 to DM31511

Parameters for Automatic Data Link Creation with 1:N Allocation: D30000 + 100 × (Unit No.) + 12 to 25

• Common Type

	15						8	7							0	
N+12	1:N allocation type (Set value 0001 = Common type)															
N+13	Start word for Area 1 (bit-access area, BCD)															
N+14	Area 1 type							00								
N+15	Area 1 send size (number of words) for master node (BCD)															
N+16	Area 1 send size (number of words) for slave nodes (BCD)															
N+17	Rightmost 4 digits of start word of Area 2 (DM Area) (BCD)															
N+18	Area 2 type							Leftmost digit of start word of Area 2 (BCD)								
N+19	Area 2 send size (number of words) for master node (BCD)															
N+20	Area 2 send size (number of words) for slave nodes (BCD)															
N+21	First word to store data link status (bit-access area) (BCD)															
N+22	16	15	14	13	12	11	10	9	8	7	6	5	4	3	2	1
N+23	32	31	30	29	28	27	26	25	24	23	22	21	20	19	18	17
N+24	48	47	46	45	44	43	42	41	40	39	38	37	36	35	34	33
N+25	–	–	62	61	60	59	58	57	56	55	54	53	52	51	50	49

Words N+22 through N+25 register nodes that will participate in the data links. The numbers shown in the table are the node addresses. The bit status for each node address indicates whether the node is to participate in the data links.

ON (1): Participate

OFF (0): Not participate

• 1 to 1 Type

	15						8	7							0	
N+12	1:N allocation type setting (Set value 0002 = 1 to 1 type)															
N+13	Rightmost 4 digits of start word (BCD)															
N+14	Area							Leftmost digit of area start word (BCD)								
N+15	Number of common send words in master node (BCD)															
N+16	Number of individual send words in master node (BCD)															
N+17	Number of send words per slave node (BCD)															
N+18	0000 (Reserved area)															
N+19	0000 (Reserved area)															
N+20	0000 (Reserved area)															
N+21	First word to store data link status (bit-access area) (BCD)															
N+22	16	15	14	13	12	11	10	9	8	7	6	5	4	3	2	1
N+23	32	31	30	29	28	27	26	25	24	23	22	21	20	19	18	17
N+24	48	47	46	45	44	43	42	41	40	39	38	37	36	35	34	33
N+25	–	–	62	61	60	59	58	57	56	55	54	53	52	51	50	49

Words N+22 through N+25 register nodes that will participate in the data links. The numbers shown in the table are the node addresses. The bit status for each node address indicates whether the node is to participate in the data links.

ON (1): Participate

OFF (0): Not participate

• Chain Type

	15											8	7											0
N+12	1:N allocation type setting (Set value 0003 = Chain type)																							
N+13	Rightmost 4 digits of area start word (BCD)																							
N+14	Area								Leftmost digit of area start word (BCD)															
N+15	Number of common send words in master node (BCD)																							
N+16	Number of receive and send words per node (BCD)																							
N+17	0000 (Reserved area)																							
N+18	0000 (Reserved area)																							
N+19	0000 (Reserved area)																							
N+20	0000 (Reserved area)																							
N+21	First word to store data link status (bit-access area) (BCD)																							
N+22	16	15	14	13	12	11	10	9	8	7	6	5	4	3	2	1								
N+23	32	31	30	29	28	27	26	25	24	23	22	21	20	19	18	17								
N+24	48	47	46	45	44	43	42	41	40	39	38	37	36	35	34	33								
N+25	-	-	62	61	60	59	58	57	56	55	54	53	52	51	50	49								

Words N+22 through N+25 register nodes that will participate in the data links. The numbers shown in the table are the node addresses. The bit status for each node address indicates whether the node is to participate in the data links.

- ON (1): Participate
- OFF (0): Not participate

CVM1 and CV-series PLCs

Auxiliary Area

Word(s)	Bit(s)	Function
A001	00 to 15	CPU Bus Unit Restart Bits
A015	00 to 15	CPU Bus Service Disable Bits
A302	00 to 15	CPU Bus Unit Initializing Flags
A401	12	CPU Bus Error Flag
A402	03	CPU Bus Unit Setting Error Flag
	07	CPU Bus Unit Error Flag
A405	00 to 15	CPU Bus Unit Error Unit Number
A410	00 to 15	CPU Bus Unit Duplicate Number
A422	00 to 15	CPU Bus Unit Error Unit Number
A427	00 to 15	CPU Bus Unit Setting Error Unit Number
A502	00 to 07	Port #0 to #7 Enabled Flags
	08 to 15	Port #0 to #7 Execute Error Flags
A503 to A510	00 to 15	Port #0 to #7 Completion Codes (See page 156.)

CPU Bus Unit Restart Bits

Bits A00100 through A00115 can be turned ON to reset CPU Bus Units number #0 through #15, respectively. The Restart Bits are turned OFF automatically when restarting is completed. Do not turn these bits ON and OFF in the program; manipulate them from the CVSS.

CPU Bus Service Disable Bits

Bits A01500 through A01515 can be turned ON to stop service to CPU Bus Units numbered #0 through #15, respectively. Turn the appropriate bit OFF again to resume service to the CPU Bus Unit.

CPU Bus Unit Initializing Flags

Bits A30200 through A30215 turn ON while the corresponding CPU Bus Units (Units #0 through #15, respectively) are initializing.

CPU Bus Error and Unit Flags

Bit A40112 is turned ON when an error occurs during the transmission of data between the CPU Unit and CPU Bus Units, or a WDT (watchdog timer) error occurs in a CPU Bus Unit. The unit number of the CPU Bus Unit involved is contained in word A405.

Bits A40500 through A40515 correspond to CPU Bus Units #0 through #15, respectively. When a CPU Bus Error occurs, the bit corresponding to the unit number of the CPU Bus Unit involved is turned ON.

CPU Bus Unit Setting Error Flag and Unit Number

Bit A40203 is turned ON when the CPU Bus Units actually installed differ from the Units registered in the I/O table. The unit number of the CPU Bus Unit involved is written to word A427.

Bits A42700 through A42715 correspond to CPU Bus Units #0 through #15, respectively. When a error occurs, the bit corresponding to the unit number of the CPU Bus Unit involved is turned ON.

CPU Bus Unit Error Flag and Unit Numbers

Bit A40207 is turned ON when a parity error occurs during the transmission of data between the CPU Unit and CPU Bus Units. The unit number of the CPU Bus Unit involved is written to word A422.

Bits A42200 through A42215 correspond to CPU Bus Units #0 through #15, respectively. When a CPU Bus Unit Error occurs, the bit corresponding to the unit number of the CPU Bus Unit involved is turned ON.

CPU Bus Unit Numbers

Bits A41000 through A41015 correspond to CPU Bus Units #0 through #15, respectively. When two CPU Bus Units have the same unit number, the bits corresponding to the unit numbers of the CPU Bus Units involved are turned ON.

Network Status Flags

Bits A50200 through A50207 are turned ON to indicate that ports #0 through #7, respectively, are enabled for the SEND(192), RECV(193), and CMND(194). Bits A50208 through A50215 are turned ON to indicate that an error has occurred in ports #0 through #7, respectively, during data communications using SEND(192), RECV(193), or CMND(194).

A503 through A510 contain the completion codes for ports #0 through #7, respectively, following data communications using SEND(192), RECV(193), or CMND(194).

CIO Area: CPU Bus Unit Area

The CPU Bus Unit Area is allocated to CPU Bus Units according to the unit numbers assigned to them, as shown below. Each Unit is allocated 25 words. The Controller Link Units use 22 of the words allocated to them.

Unit no.	Words	Unit no.	Words
0	1500 to 1524	8	1700 to 1724
1	1525 to 1549	9	1725 to 1749
2	1550 to 1574	10	1750 to 1774
3	1575 to 1599	11	1775 to 1799
4	1600 to 1624	12	1800 to 1824
5	1625 to 1649	13	1825 to 1849
6	1650 to 1674	14	1850 to 1874
7	1675 to 1699	15	1875 to 1899

Error Information: CIO 1500 + 25 x (Unit No.) (See page 254.)

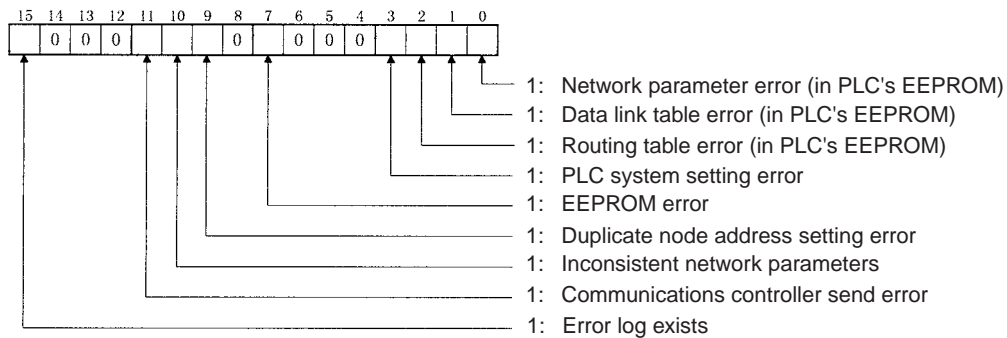

Polling Node Address, Startup Node Address: CIO 1500 + 25 x (Unit No.) + 1 (See page 254.)

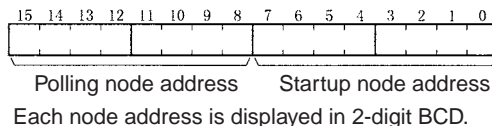

Network Participation Status: CIO 1500 + 25 x (Unit No.) + 2, + 3 (See pages 155, 255.)

	15	14	13	12	11	10	9	8	7	6	5	4	3	2	1	0
+2CH	16	15	14	13	12	11	10	9	8	7	6	5	4	3	2	1
+3CH	32	31	30	29	28	27	26	25	24	23	22	21	20	19	18	17
+4CH	48	47	46	45	44	43	42	41	40	39	38	37	36	35	34	33
+5CH	—	—	62	61	60	59	58	57	56	55	54	53	52	51	50	49

The numbers in the squares indicate node addresses.
 The corresponding node participation status is as follows:
 0: Not participating in the network
 1: Participating in the network

Note If the local node is not participating in the network, the status for the local node will be 0 (not participating), and the status for the other nodes will be indefinite.

Local Data Link Participation Status: CIO 1500 + 25 x (Unit No.) + 6 (See page 255.)

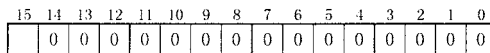

1: Local node data link participating
 0: Local node data link not participating or data link inactive

Data Link Status: CIO 1500 + 25 x (Unit No.) + 7 to + 22 (See pages 130, 255.)

When the first data link status word for manually set data link tables or for automatically set data links is not set or is set to 0, the data link status is stored in the words shown below.

When 8-bit Format is Specified

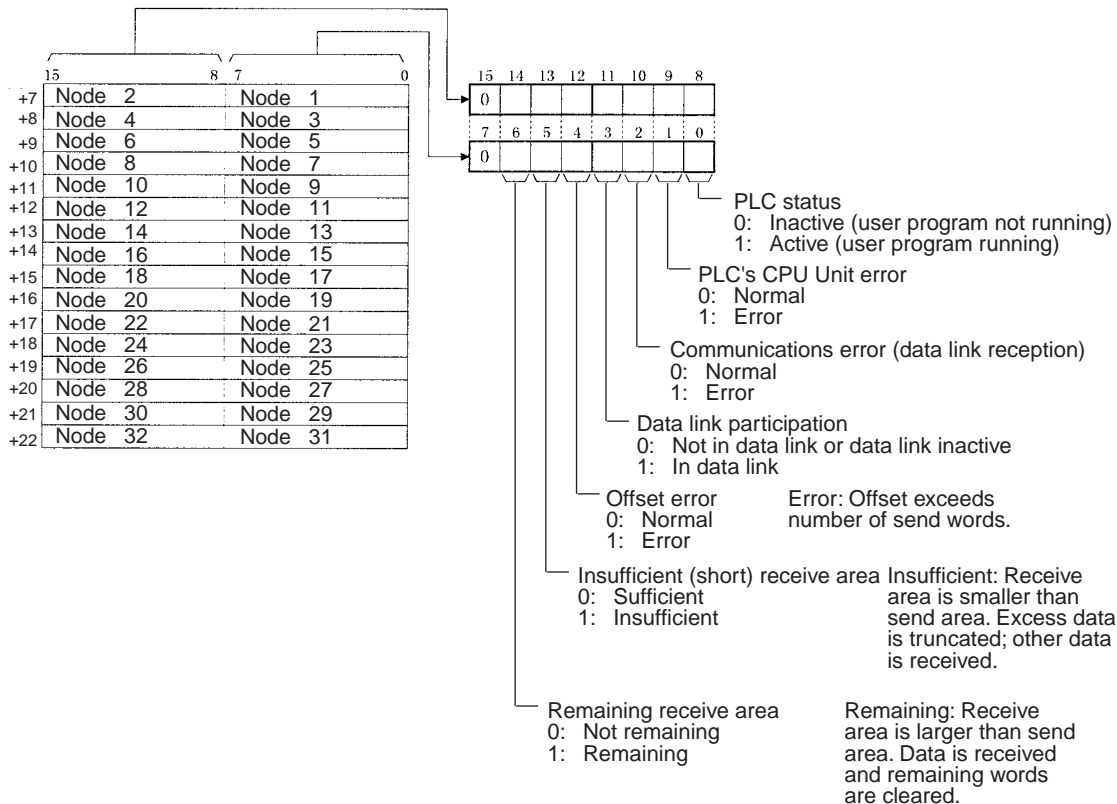

When 4-bit Format is Specified

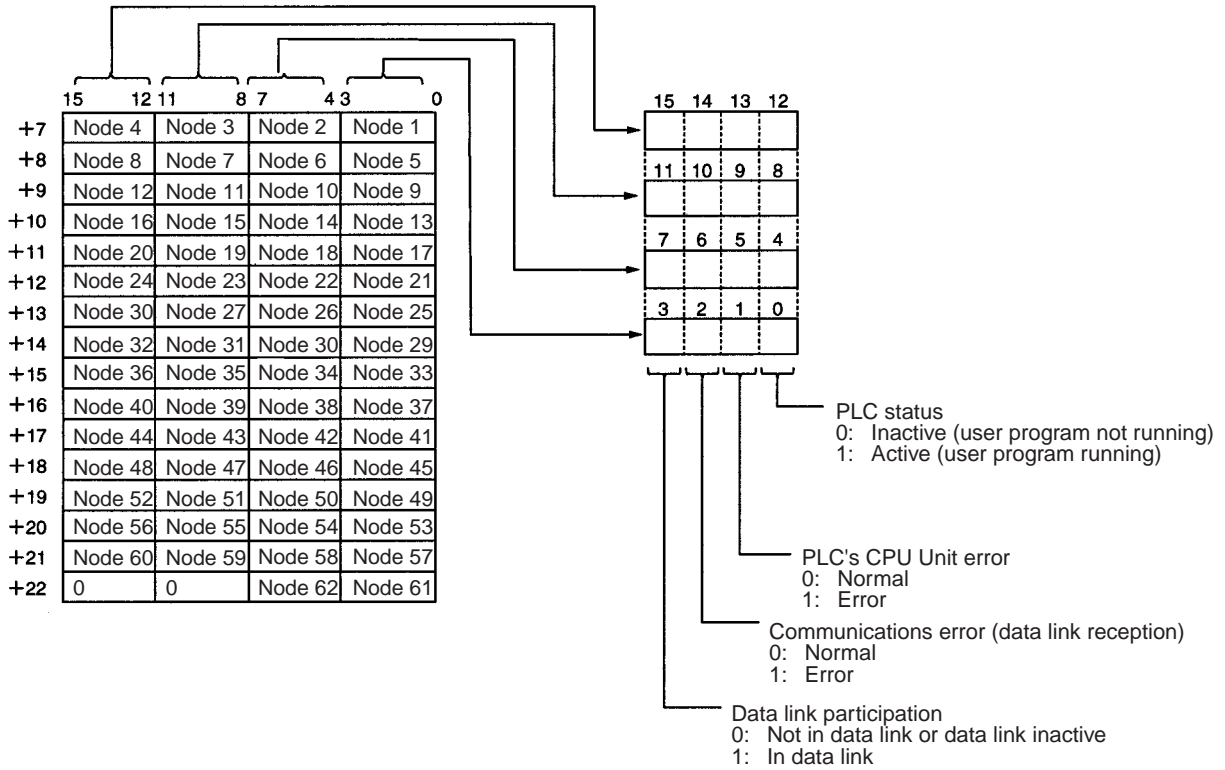

Note Refer to 5-4 Checking Data Link Status for details on status flags.

Ring Status: CIO 1500 + 25 x (Unit No.) + 23

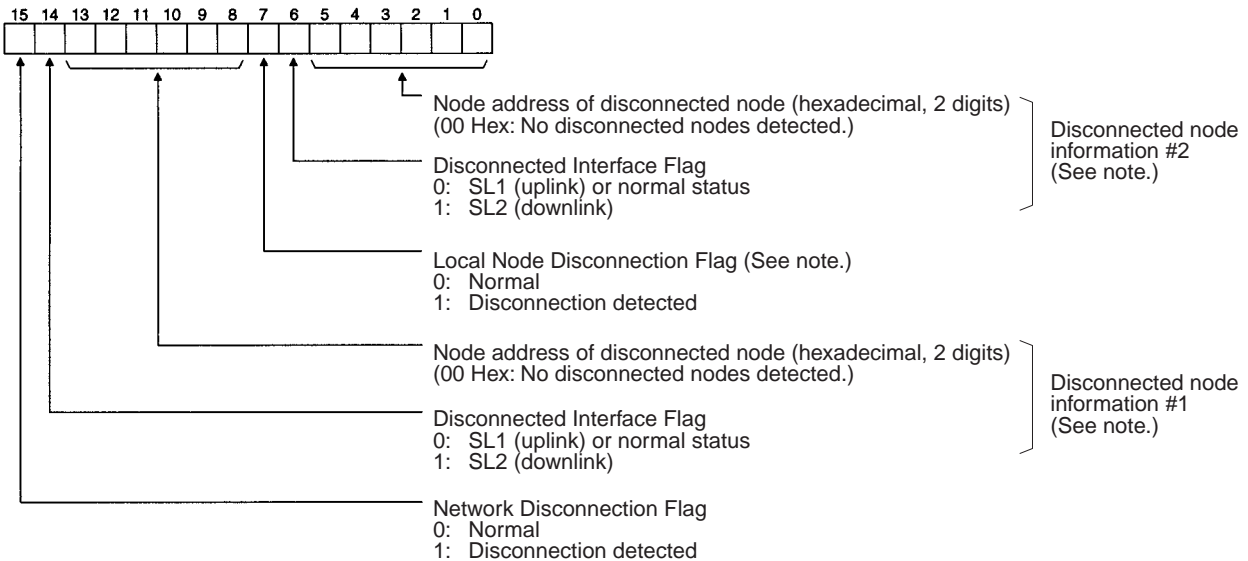

Note The disconnected node information is valid only when bit 15 (the Network Disconnection Flag) is ON. If bit 15 is OFF, the earlier disconnected node information and Local Node Disconnection Flag status is retained.

Power Status: CIO 1500 + 25 x (Unit No.) + 24

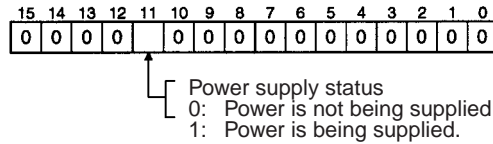

DM Area: CPU Bus Unit Area

The CPU Bus Unit Area (data memory) is allocated to CPU Bus Units according to the unit numbers assigned to them, as shown below. Each Unit is allocated 100 words, of which 12 words are used. In the Controller Link Unit this area is called the DM Area.

Unit no.	Words	Unit no.	Words
0	DM2000 to DM2011	8	DM2800 to DM2811
1	DM2100 to DM2111	9	DM2900 to DM2911
2	DM2200 to DM2211	10	DM3000 to DM3011
3	DM2300 to DM2311	11	DM3100 to DM3111
4	DM2400 to DM2411	12	DM3200 to DM3211
5	DM2500 to DM2511	13	DM3300 to DM3311
6	DM2600 to DM2611	14	DM3400 to DM3411
7	DM2700 to DM2711	15	DM3500 to DM3511

Software Switches (DM2000 + 100 × Unit No.)

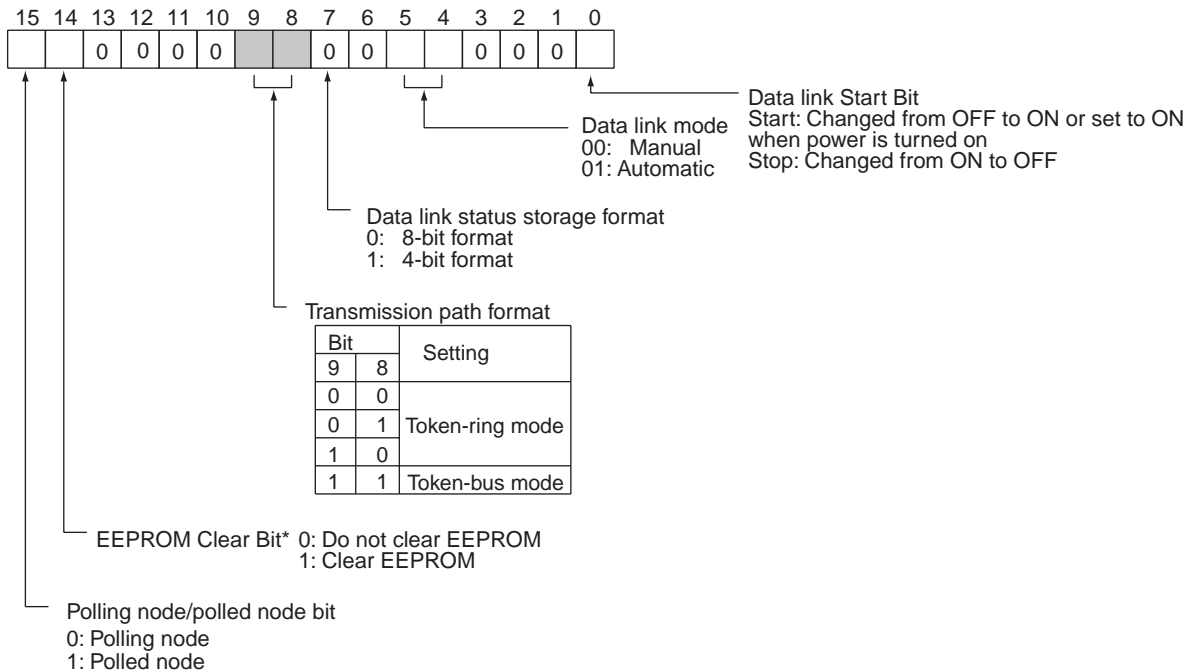

*Clears the network parameters, data link tables, and routing tables stored in EEPROM in the PLC's CPU Unit.

Parameters for Automatically Setting Data Links: DM 2000 + 100 x (Unit No.) + 1 to + 11 (See page 123.)

	15	8	7	0
+1	Area 1 data link start word (BCD)			
+2	Area 1 type		00	
+3	Number of send words per node of area 1 (BCD)			
+4	Rightmost 4 digits of data link start word of area 2(BCD) _ _ _ _			
+5	Area 2 type		Leftmost digit of data link start word of area 2 (BCD)	
+6	Number of send words per node of area 2 (BCD)			
+7	First data link status word (BCD)			

	15	14	13	12	11	10	9	8	7	6	5	4	3	2	1	0
+8	16	15	14	13	12	11	10	9	8	7	6	5	4	3	2	1
+9	32	31	30	29	28	27	26	25	24	23	22	21	20	19	18	17
+10	48	47	46	45	44	43	42	41	40	39	38	37	36	35	34	33
+11	-	-	62	61	60	59	58	57	56	55	54	53	52	51	50	49

← Nodes to participate in the data links
 The numbers indicate node numbers.
 The value assigned indicates whether the node is to participate in the data links.
 Participate: 1
 Not participate: 0

-: Not used. BCD: Set the value as binary-coded decimal.

Note N+10 and N+11 (node addresses 33 to 62) cannot be used in Optical Bus Systems.

Appendix B

Standard Models

Controller Link Units

Applicable PLC	Model number	Specifications	Remarks
CS-series PLCs	CS1W-CLK13 CS1W-CLK12-V1	Optical Ring System (H-PCF Cable)	See <i>CPU Units and Programming Devices</i> in this appendix.
	CS1W-CLK53 CS1W-CLK52-V1	Optical Ring System (GI Cable)	
	CS1W-CLK11	Optical Bus System	
CVM1 and CV-series PLCs	CVM1-CLK12	Optical Ring System (H-PCF Cable)	
	CVM1-CLK52	Optical Ring System (GI Cable)	

Controller Link Support Board

Computer slot	Model number	Remarks
PCI	3G8F7-CLK13 3G8F7-CLK12-V1 (Optical Ring System (H-PCF Cable))	Compatible operating systems: Windows 98, Windows 2000, or Windows NT 4.0
	3G8F7-CLK53 3G8F7-CLK52-V1 (Optical Ring System (GI Cable))	

Special Software

Applicable computers	Name	Model number	Applicable PLCs
IBM PC/AT or compatible running Windows 98SE, Me, 2000, XP, or NT 4.0	CX-Integrator	CXONE-AL□□C-EV2 CXONE-AL□□D-EV2	CS/CJ-series
IBM PC/AT or compatible running Windows 95 (See note.), 98, NT 4.0, 2000, or XP	CX-Programmer (including CX-Net)	WS02-CXPC□-EV□ (version 2.1 or higher)	CS, CJ, C200HX/HG/HE, CVM1/CV, or CQM1H Series

Note Windows 95 cannot be used when connected through a Controller Link Support Board (PCI Bus) or SYSMAC LINK Support Board (PCI Bus).

H-PCF Optical Fiber Cable Connectors and Accessories

Optical Fiber Cables (Indoor Use Only)

Name	Specifications		Model
H-PCF cables	Black	10 m	S3200-HCCB101
		50 m	S3200-HCCB501
		100 m	S3200-HCCB102
		500 m	S3200-HCCB502
		1,000 m	S3200-HCCB103
	Orange	10 m	S3200-HCCO101
		50 m	S3200-HCCO501
		100 m	S3200-HCCO102
		500 m	S3200-HCCO502
		1,000 m	S3200-HCCO103

Note The optical fiber cable model numbers are as follows.

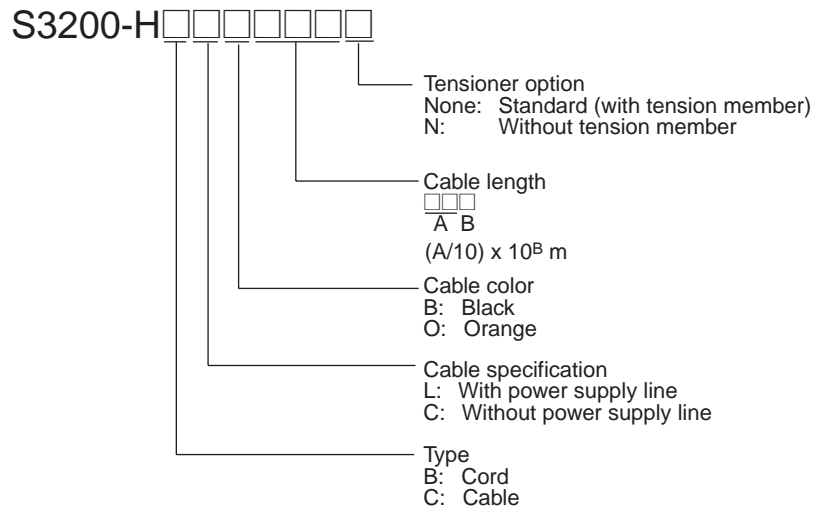

Connectors

Name	Model	Remarks
Optical Connector	S3200-COCF2071	Connects a cable to a node. Two connectors are required for each cable. (Full-lock connector for crimp-cut cable.)
	S3200-COCF2571	Connects a cable to a node. Two connectors are required for each cable. (Half-lock connector for crimp-cut cable.)
Inline Adapter	S3200-COIAT2000	Connects two cables. One adapter is required to connect two cables.

Discontinued Models

Name	Model	Recommended replacement	Manufacturer
Optical Connector	S3200-COCF2011	S3200-COCF2071	OMRON
	S3200-COCF2511	S3200-COCF2571	

Optical Fiber Cables with Connectors (Indoor Use Only)

The following Optical Fiber Cables are available with Connectors already attached. (These cables have power supply lines and tension members, which aren't used in the Controller Link Network.)

Specifications	Length	Model
Optical Fiber Cable Connectors: S3200-COCF2071 ↓ S3200-COCF2071	2 m	S3200-CN201-20-20
	5 m	S3200-CN501-20-20
	10 m	S3200-CN102-20-20
	15 m	S3200-CN152-20-20
	20 m	S3200-CN202-20-20
	Over 20 m	S3200-CN-20-20 (Specify length (m) when ordering.)
Optical Fiber Cable Connectors: S3200-COCF2071 ↓ S3200-COCF2571	2 m	S3200-CN201-20-25
	5 m	S3200-CN501-20-25
	10 m	S3200-CN102-20-25
	15 m	S3200-CN152-20-25
	20 m	S3200-CN202-20-25
	Over 20 m	S3200-CN-20-25 (Specify length (m) when ordering.)
Optical Fiber Cable Connectors: S3200-COCF2571 ↓ S3200-COCF2571	2 m	S3200-CN201-25-25
	5 m	S3200-CN501-25-25
	10 m	S3200-CN102-25-25
	15 m	S3200-CN152-25-25
	20 m	S3200-CN202-25-25
	Over 20 m	S3200-CN-25-25 (Specify length (m) when ordering.)

Note Special training is required to assemble Optical Fiber Cables and connectors with epoxy adhesive. Contact your OMRON dealer for details on other optical fiber cords and cables.

The Optical Fiber Cables listed here are for indoor use only. Consult a specialist tradesman if cables with outdoor specifications are required.

Duplex Unit Connecting Cable

This cable is used to connect Controller Link Units (CS1W-CLK13/12-V1) used in duplex operation in a CS1D System.

Name: Duplex Unit Connecting Cable

Length: 50 cm

Model number: CS1D-CN051

- Note**
1. This cable (CS1D-CN051) is used to connect Controller Link Units used in duplex operation. To connect standard nodes, use an Optical Fiber Cable with a connector (S3200-CN□□□-□□-□□).
 2. Controller Link Units (CS1W-CLK13/12-V1) used in duplex operation can also be connected by a standard H-PCF cable. (Use a cable no longer than the maximum allowable distance between standard nodes.)

Assembly Tools

The following tools are used to assemble optical networks.

Specifications	Specifications	Model
Optical Connector Assembly Tool	Applicable Connector: S3200-COCF2071/2571	CAK-0057 (See note.)
Optical Power Tester	Enclosed Head Unit: CAT-2702 Applicable Connector: S3200-COCF2071/2571	CAT-2700
Master Fiber	Applicable Head Unit: CAT-2702	CAT-2001H

Note The S3200-COCF2071/2571 Optical Connector can still be assembled if the JRFK-57PLUS (Sumitomo Electric Industries) is added to the S3200-CAK1062.

Discontinued Models

Name	Model	Specifications	Manufacturer
Optical Connector Assembly Tool	S3200-CAK1062	Optical connector: S3200-COCF2011/ 2511	OMRON

GI Optical Fiber Cable Connectors and Accessories

Required Optical Characteristics

50/125 μm AGF Cable

Item	Minimum	Standard	Maximum	Unit	Conditions	
Numerical Aperture (N.A.)	---	0.21	---	---	Theoretical value	
Transmission loss	---	---	3.0 Lf	dB	$0.5 \text{ km} \leq L_f$	$\lambda = 0.8 \mu\text{m}$ $T_a = 25^\circ\text{C}$
			3.0 Lf + 0.2		$0.2 \text{ km} \leq L_f < 0.5 \text{ km}$	
			3.0 Lf + 0.4		$L_f < 0.2 \text{ km}$	
Connection loss	---	---	1.0		$\lambda = 0.8 \mu\text{m}$, one location	
Transmission bandwidth	500	---	---	MHz·km	$\lambda = 0.85 \mu\text{m}$ (LD)	

Note L_f is fiber length in km, T_a is ambient temperature, and λ is the peak wavelength of the test light source.

62.5/125 μm AGF Cable

Item	Minimum	Standard	Maximum	Unit	Conditions	
Numerical Aperture (N.A.)	---	0.28	---	---	Theoretical value	
Transmission loss	---	---	3.5 Lf	dB	$0.5 \text{ km} \leq L_f$	$\lambda = 0.8 \mu\text{m}$ $T_a = 25^\circ\text{C}$
			3.5 Lf + 0.2		$0.2 \text{ km} \leq L_f < 0.5 \text{ km}$	
			3.5 Lf + 0.4		$L_f < 0.2 \text{ km}$	
Connection loss	---	---	1.0		$\lambda = 0.8 \mu\text{m}$, one location	
Transmission bandwidth	200	---	---	MHz·km	$\lambda = 0.85 \mu\text{m}$ (LD)	

Note L_f is fiber length in km, T_a is ambient temperature, and λ is the peak wavelength of the test light source.

Connectors

Name	Model	Manufacturer
ST Connector	CAS-125	Sumitomo Electric Industries

Appendix C

CS-series Optical Bus Controller Link Units

Component Names and Functions

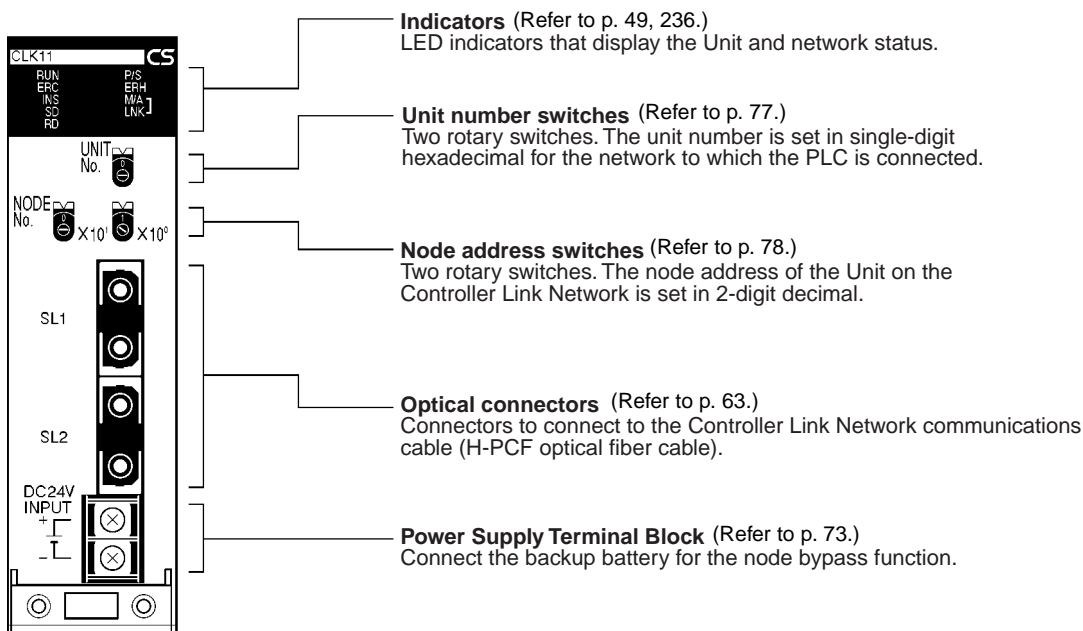

Optical Unit Indicators

Name	Color	Status	Meaning	
RUN (operating)	Green	Lit	Unit operating normally.	
		Not lit	Unit error.	
P/S (power supply)	Green	Lit	Backup power is being supplied.	
		Not lit	Backup power is not being supplied.	
ERC (communica- tions error)	Red	Lit	Communications error, node address setting error, hardware error or a connection error between the Optical Controller Link Unit and SYSMAC LINK.	
		Not lit	Normal operation	
ERH (PLC error)	Red	Lit	PLC error, PLC interface error, EEPROM error, unit number error, or I/O table not set.	
		Not lit	No error.	
INS (network participation)	Yellow	Lit	Unit is participating (inserted) in the network.	
		Not lit	Unit is not participating (inserted) in the network.	
SD (send)	Yellow	Lit	Data transmission.	
		Not lit	No data transmission.	
RD (receive)	Yellow	Lit	Data reception.	
		Not lit	No data reception.	
M/A (data link mode)	Yellow	Lit	Manual (See note.)	Note: M/A is always not lit when data links are not active in the network.
		Not lit	Automatic	
LNK (data link)	Yellow	Lit	Data links participating.	
		Flashing	Error in data link table.	
		Not lit	Not in a data link or data link inactive.	

Note Even when the local node does not participate in the data link, the indicator will be lit if there are manually set data links active on the network.

For details refer to 10-1 Troubleshooting Using Indicators.

Overview

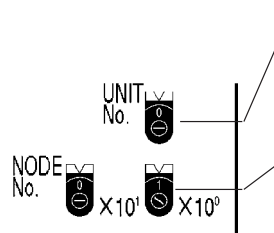
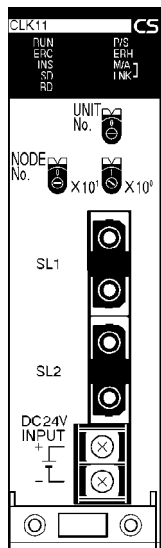

Unit Number

Setting range	Nodes
00 to F (default is 0)	All nodes in the Network

Node Address

Setting range	Nodes
01 to 32 (default is 01)	All nodes in the Network

Unit Number

Set the unit number for each Unit using the rotary switches on the front of the Unit. The unit number is used to identify a CPU Bus Unit within the PLC. Any unit number can be set between 0 and F in hexadecimal (00 to 15 in decimal).



Note: The factory default settings are shown above.

Item	Specifications
Setting method	Single-digit hexadecimal
Setting range	0 to F (decimal 00 to 15, default is 0)
Node	All nodes in the Network

Set the node address using a small flat-blade screwdriver, being careful not to damage the rotary switches.

- Note**
1. Always turn OFF the PLC's power before setting the unit number.
 2. When setting a Unit for the first time or changing the existing setting, create a I/O table in the PLC's CPU Unit.
 3. Do not set the same unit number twice within the same PLC. An error will occur if the same unit number is set for two different Unit, and the CPU Unit will not be able to recognize the Units.
 4. When the Unit is recognized by the PLC's CPU Unit, "NS" will be shown in the I/O table displayed for the CX-Programmer programming device.
 5. The default setting is "0."
 6. The unit number determines the words used by the Controller Link Unit in PLC memory.

Node Addresses

Set the node address of each Unit in the Network using the rotary switch on the front of the Unit. The node address is used to identify each node in the Network.

The node address can be set to any value between 01 and 32.

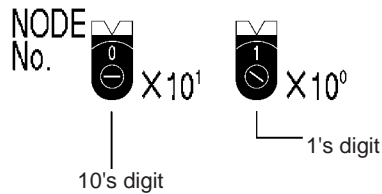

Note: The factory default settings are shown above.

Item	Specifications
Setting method	2-digit decimal
Setting range	01 to 32 (default is 01)
Node	All nodes in the Network

Set the node address using a small flat-blade screwdriver, being careful not to damage the rotary switches.

- Note**
1. Always turn OFF the PLC's power before setting the node address.
 2. Do not set the same node address twice within the same Network. An error will occur if the same address is set for two different nodes. The ERC indicator on the front of the Unit will light (Communications Error Flag) and either communications will stop, or the INS indicator will not light and you will be unable to participate in the Network.
 3. The send sequence for the data link areas is determined according to the sequence of node addresses for automatically set data links.
 4. Assign node addresses consecutively beginning from 01 whenever possible to minimize Network construction time.

Communications Specifications

Optical Ring System

Items	Specifications
Communications method	N:N token bus
Code	Manchester code
Modulation	Baseband code
Synchronization	Flag synchronization (conforms to HDLC frames)
Transmission path form	Daisy-chain
Baud rate	2 Mbps
Maximum transmission distance	20 km
Maximum distance between nodes	Crimp cut: 800 m Adhesive: 1 km (See note 1.)
Media	H-PCF cable (optical two-core cable)
Node connection method	Connected via a special (full-lock connector) connector. (A half-lock connector can also be used.)
Maximum number of nodes	32 nodes
Communications functions	Data links and message service
Number of data link words	Transmission area per node: 1,000 words (2,000 bytes) max. Data link area in one PLC (CS-series PLC) (send/receive): 12,000 words (24,000 bytes) max. Number of data link words in one network (total transmission): 32,000 words (64,000 bytes) max.
Data link areas	Bit areas (AR, LR (See note 2.), CIO), data memory (DM), and extended data memory (EM)
Message length	2,012 bytes max. (including the header)
RAS functions	Polling node backup function Self-diagnosis function (hardware checking at startup) Echoback test and broadcast test (using the FINS command) Watchdog timer Error log function Node bias function
Error control	Manchester code check CRC check ($CCITT X^{16} + X^{12} + X^5 + 1$)

- Note**
1. The maximum distance between nodes depends on the connector and cable processing methods.
 2. The CS-series PLCs do not have an LR area, but CIO 1000 through CIO 1199 are used automatically in place of LR 000 to LR 199.

Dimensions (Unit: mm)

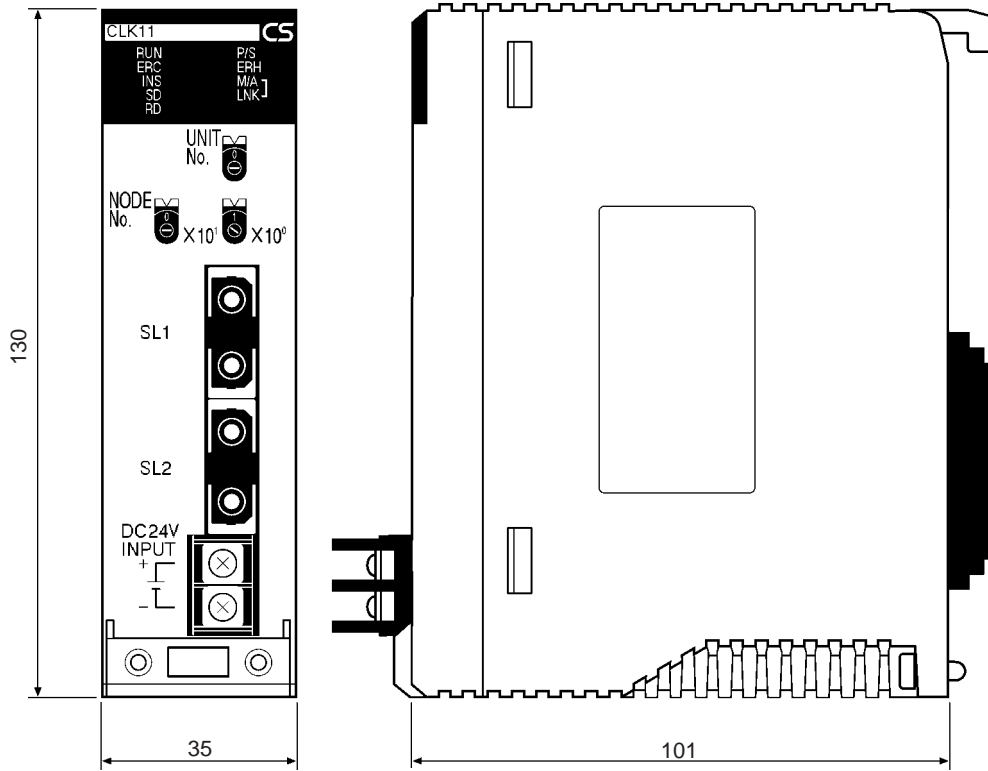

Appendix D

Handling and Using GI Cable

Optical Fiber Cable is constructed to withstand the handling necessary during normal installation and usage, but unlike copper wiring, special tools and skills are required to repair Optical Fiber Cable if it is accidentally cut. Plan the installation carefully to avoid damaging the cables.

Transport and Storage

Optical Fiber Cable is wound on a standard drum. It can be transported just like copper wire cables, but it is lighter than copper wire cable so be sure to use less force when handling the Optical Fiber Cable.

Optical Fiber Cable can be stored at temperatures between -40°C and 70°C . To prevent the infiltration of humidity, seal both ends of the cable with cable caps or other means. Be especially careful to prevent the infiltration of moisture when connectors are attached to the ends of the cable.

Installation Precautions

There are limits on the maximum tension and minimum bending radius that the Optical Fiber Cable can withstand. Handle the cable carefully because the cable may break or have increased transmission loss if these limits are exceeded.

Pulling Tension

The pulling tension on the cable can be measured with a pulley as shown in the following diagram.

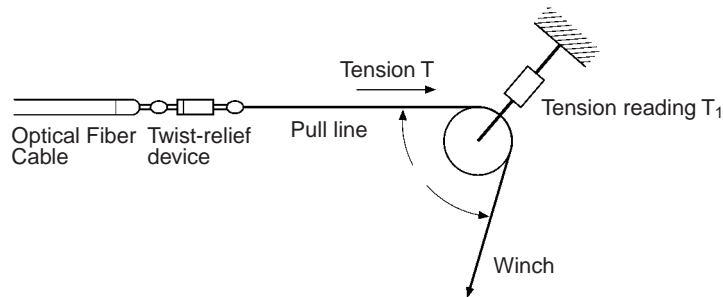

The pulling tension (T) on the cable can be calculated from the tension reading (T_1) at the pulley and the angle (θ) at the pulley.

$$T = \frac{T_1}{2 \cos \frac{\theta}{2}}$$

If the pulling tension exceeds the maximum tension, install a pull box midway through the run as shown in the following diagram. Pull the required amount of cable to the pull box, lay it out in figure-8 loops, and then pull the cable through the remaining section of the run.

The Optical Fiber Cable's characteristics will deteriorate if the cable remains under tension for a long period, so be sure to release the tension after installing the cable.

Pull Box and Figure-8 Loops

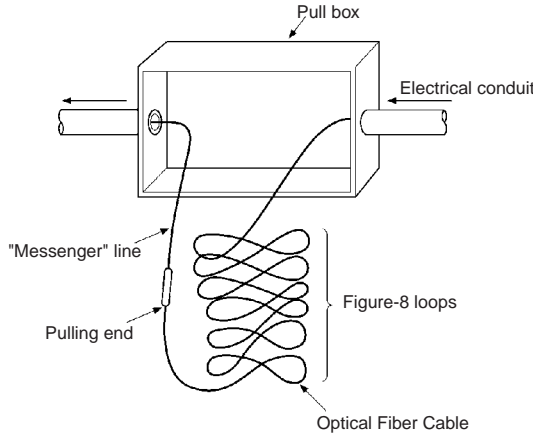

Bending Radius

The minimum bending radius for Optical Fiber Cable is generally about 10 times the cable's diameter. Bending the cable in a smaller radius can increase its transmission loss or break the fiber completely. Bends in the conduit must be at least 20 times the cable's diameter due to the tension member's characteristics.

When reusing existing conduit, take steps such as installing pull boxes at sharp turns to avoid damaging the cables.

Splicing Optical Fiber Cables

There are two methods that can be used to splice Optical Fiber Cables.

Fused Connection

With this method, the ends of the fibers are brought together and fused by applying heat from an electrical arc or other source. This method can provide a low-loss and stable connection; it can be used in a variety of applications including splicing cables and attaching a cable to a connector with an attached cord.

Special equipment and skills are required for this technique, so this project must be contracted to an Optical Fiber Cable manufacturer or company specializing in fiber-optic cable repairs.

Example

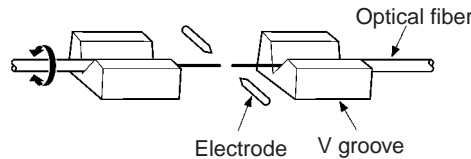

Connector Connection

If a connector is attached to the optical fiber, the fiber can be connected easily with a connector adapter.

Example

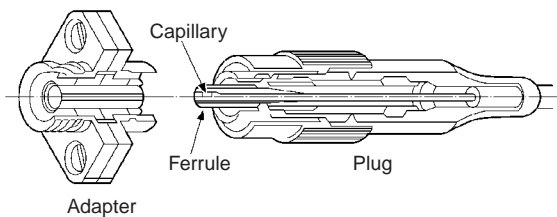

This connection is easy to connect and disconnect, but it can have a relatively high transmission loss so there must be excess capacity in the system.

Note When optical fibers are joined by a fused connection or connector connection, the loss between nodes must be within the limits shown in the following table.

Cable	Allowable loss
50/125 μm	3 dB/km
62.5/125 μm	3.5 dB/km

Measuring Light Loss

Measure the transmission loss when the Optical Fiber Cable is installed and during periodic inspections to determine whether an optical fiber has broken, disconnected, or deteriorated.

Cutback Method

The CCITT (International Telegraph and Telephone Consultative Committee) and IEC (International Electrotechnical Commission) have adopted the cutback method as the standard technique for measuring transmission loss.

Theory

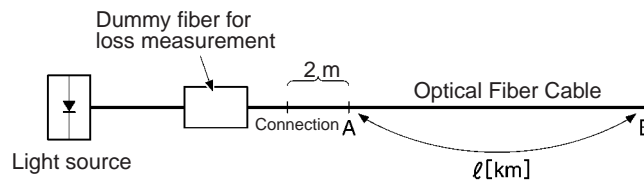

Connect the dummy fiber to the fiber that is being measured and measure the light power (P_1) at point B. Next, disconnect the ℓ km of fiber at point A and measure the light power (P_0) at point A. The loss in the measured fiber is simply the difference between these two measurements.

$$\alpha = \frac{P_0 - P_1}{\ell} \text{ [dB/km]}$$

Points A and B are often separated by some distance, so 2 calibrated power meters are actually required to measure the light power at the two points.

Simple Measurement with a Light Tester

A light tester can be used to take a simple loss measurement, as shown in the following diagram.

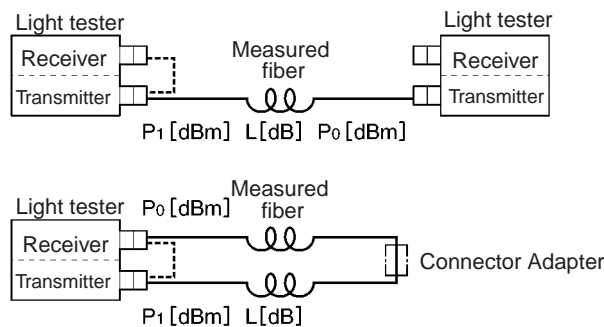

First, the light tester is self-calibrated by connecting a short fiber cord between the transmitter and receiver. Next, the fiber to be measured is connected to calculate the difference between the transmitted light power (P_1 dBm) and the received light power (P_0 dBm).

$$\text{Fiber loss: } L = P_1 - P_0 \text{ dB}$$

When a two-core cable is being used, a Connector Adapter can be connected to the far end of the cable and the round-trip transmission loss through the entire cable can be measured with a single light tester.

Maintaining the Optical Fiber Cables

Locating Faults in the Cables

After the Optical Fiber Cable has been installed, obstructions in the fibers can occur due to accidental damage or changes in the operating environment. A fault locator is used to locate these optical obstructions.

The fault locator is a measuring device that indicates the amount of transmission loss and the distance to connections/fractures in the optical fiber from the strength and timing of light back-scattered from those points.

A fault indicator will show slight increases in transmission loss caused by damaged points, so damage can be discovered very quickly. The following diagram shows how a fault locator operates.

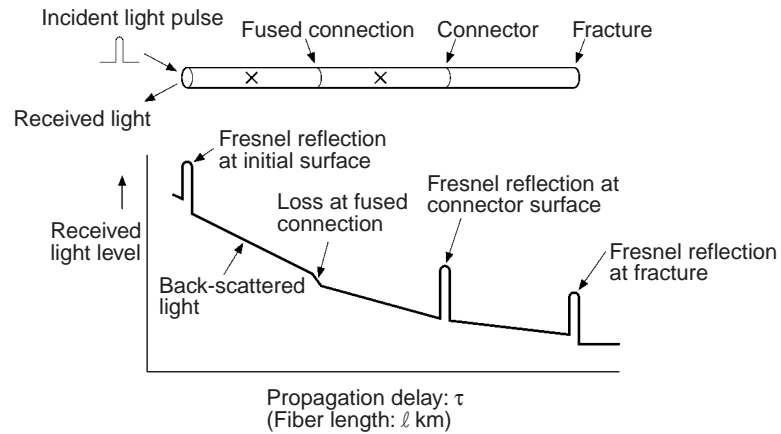

Index

A

- applications precautions, xxiv, 31
- asynchronous operation, 229
- automatic setting
 - setting example, 125
- auxiliary area bits/words and PLC setup settings, 214

B

- backup power supply, 29
 - cable connections, 73
 - wiring, 67

C

- cables, 8
 - for duplex operation, 206
 - optical, 21, 24
 - Optical Fiber Cables
 - GI, 65
 - H-PCF, 63
- CMND instruction
 - message service, 142
- commands
 - FINS commands, 160
- commands for Controller Link Units, 162
 - BROADCAST TEST DATA SEND, 175
 - BROADCAST TEST RESULTS READ, 174
 - CONTROLLER DATA READ, 163
 - CONTROLLER STATUS READ, 164
 - DATA LINK START, 163
 - DATA LINK STATUS READ, 168
 - DATA LINK STOP, 163
 - ECHOBACK TEST, 174
 - ERROR LOG CLEAR, 176
 - ERROR LOG READ, 175
 - NETWORK STATUS READ, 166
- communications
 - cables, 21
 - optical, 21, 24
 - continuation for errors, 200
 - data exchange timing, 224
 - data processing time, 225
 - instructions, 152
 - mechanism, 218
 - preparations, 36
 - recovery time
 - for duplex operation, 212

- selecting functions, 30
 - timing calculation example, 226
- Communications Cables, 21
- communications cycle time, 221
 - active data links, 221
 - definition, 218
 - non-active data links, 222
- Connectors
 - installation
 - GI Cable, 70
 - H-PCF Cable, 68
 - models, 324, 326
- Controller Link, 2
 - network
 - features, 7
 - reading operating status, 166
 - remote, 189
- Controller Link Support Boards
 - models, 323
- Controller Link Support Software, 26, 27
 - models, 323
 - stopping and starting data links, 129
- Controller Link Units
 - CS1-series
 - settings, 76
 - CVM1 and CV-series
 - settings, 79
 - models, 17, 323
- CS1-series PLCs
 - installation, 61, 62
 - memory areas, 309
 - RECV, 144
 - RECV delay time, 232
 - SEND, 143
 - SEND delay time, 230
 - SEND/RECV instructions, 143
 - synchronous operation, 227
- CVM1 and CV-series PLCs
 - asynchronous operation, 229
 - installation, 60
 - memory areas, 317
 - RECV, 146
 - RECV delay time, 232
 - SEND, 145
 - SEND delay time, 230
 - SEND/RECV instructions, 145
 - synchronous operation, 227
- CV-series PLCs
 - See also* CVM1 and CV-series PLCs

CX-Net, 28
CX-Programmer, 28, 188, 189

D

data areas
 SEND/RECV, 150

data link
 I/O response time, 224

data link table
 creating manually, 100
 specifications, 96

data links, 7
 automatic setting, 38, 107
 examples, 88
 creating, 31
 description, 86
 error detection, 135
 manual setting, 36, 95
 examples, 87, 100
 from computer node, 95
 from Programming Device, 95
 modes, 133
 procedures, 36
 reading data link status, 168
 selecting automatic or manual, 94
 setting, 94
 specifications, 92
 starting, 127, 163
 status, 130
 manipulating bit/word status, 135
 using data link status area, 130
 using indicators, 130
 stopping, 127, 163
 stopping and starting, 128

dimensions
 crimp terminals, 73
 CS1 Units, 50, 56, 331
 CVM1 and CV Units, 53, 59

duplex operation, 199
 cables, 206
 I/O tables, 208
 memory areas, 214
 overview, 200
 precautions, 210
 procedure, 204
 settings, 207
 specifications, 203
 switching time, 212
 system configuration, 202

E

EC Directives, xxvi
EMC Directives, xxvi
error codes, 261
error log, 6, 260
 reading and clearing, 267
 table, 260

errors
 clearing, 176
 error handling, 9
 error log, 6
 reading, 175
 response codes, 179

F

FINS commands
 errors, 179
 response codes
 errors, 179
 sending and receiving, 160
 responses, 160
 sending and receiving, 160
 stopping and starting data links, 129

flags
 Network Instruction Enabled Flag, 154
 Network Instruction Error Flag, 154
 SEND/RECV, 154
 SEND/RECV operations, 155

I

I/O tables, 36, 39
 for duplex operation, 208

indicators
 checking data link status, 130
 Controller Link Units
 CS1 Units, 327
 troubleshooting using indicators, 236

inspection
 tools and equipment needed, 288

installation, 36, 59
 communications cables
 GI, 65, 70
 H-PCF, 63, 68

connectors
 GI Cable, 70
 H-PCF Cable, 68

CS1-series PLCs, 61, 62
CVM1 and CV-series PLCs, 60

instructions
 CMND, 147
 RECV, 143
 SEND, 143

M

maintenance
 cleaning, 287
 inspection, 288
manual setting
 examples, 100
memory areas, 309
 for duplex operation, 214
message delay times, 230
message service, 8, 31
 operations, 153
 procedure, 44
 specifications, 153
models, 17

N

network
 interconnecting Controller Link networks, 186
 interconnecting other OMRON networks, 186
 other remote networks, 190
 parameters, 220
 specifying, 220
 relay errors, 177
 remote Controller Link networks, 189
node addresses
 setting
 CS1 Optical Units, 328
 CS1 Wired Units, 78
 CVM1 and CV Units, 82
node configurations, 8
number of polled units, 220

O

offsets
 application example, 91
 usage, 90
online replacement, 202
operating environment precautions, xxiii

Optical Fiber Cable Connectors
 models, 325

Optical Fiber Cables
 accessories, 24
 GI, 65
 H-PCF, 63
 models, 324

optical fiber cables
 See also cables

overview, 2

P

PLC
 reading controller status, 164
 receiving routing table settings, 194
PLC Setup
 settings for duplex operation, 207, 216
polled units
 number, 220
polling cycle
 definition, 218
polling node, 219
 setting, 219
power supply
 backup, 29, 67
 cable connections, 73
precautions
 applications, xxiv, 31
 for duplex operation, 210
 general, xxii
 handling, 288
 operating environment, xxiii
 replacing the Unit, 289
 safety, xxii
procedures
 message service, 31
programming
 PLC programming examples, 157
 remote, 188
Programming Devices, 25, 189

R

RAS functions, 6
RECV instruction, 143
 CS1-series PLCs, 232
 CVM1 and CV-series PLCs, 232
 data areas, 150

- message service, 142
- response codes, 156, 177, 179
 - CS1-series PLCs, 156
 - CV-series PLCs, 156
- routing tables, 190
 - creating, 191
 - editing, 193
 - saving, 194
 - setting, 192
 - examples, 194
 - procedure, 192
 - transferring, 194

S

- safety precautions, xxii
- SEND instruction, 143
 - CS1-series PLCs, 230
 - CVM1 and CV-series PLCs, 230
 - data areas, 150
 - message service, 142
- settings
 - for duplex operation, 207
 - node addresses
 - CS1 Optical Units, 328
 - CS1 Wired Units, 78
 - CVM1 and CV Units, 82
 - polling nodes, 219
 - settings after replacing Unit, 290
 - unit numbers
 - CS1 Optical Units, 328
 - CS1 Wired Units, 77
 - CVM1 and CV Units, 81
- specifications
 - backup power supply, 29
 - communications, 16
 - data link, 92
 - for duplex operation, 203
 - general, 16
 - message service, 153
- standard models, 323
- status area, 6
 - troubleshooting, 247
- stopping and starting
 - data links
 - using Controller Link Support Software, 129
 - using FINS commands, 129
- switching time
 - for duplex operation, 212
- synchronous operation, 227

- system configuration, 13

T

- transmission path format
 - for duplex operation, 205
- troubleshooting, 236
 - status area, 247
 - using indicators, 236

U

- unit numbers
 - setting
 - CS1 Optical Units, 328
 - CS1 Wired Units, 77
 - CVM1 and CV Units, 81

W

- wiring
 - Optical Controller Link Units, 63

Revision History

A manual revision code appears as a suffix to the catalog number on the front cover of the manual.

Cat. No. W370-E1-07

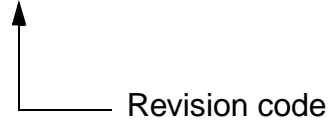

The following table outlines the changes made to the manual during each revision. Page numbers refer to the previous version.

Revision code	Date	Revised content
1	March 2000	Original production
2	November 2000	<p>Units for GI cable added. Specific changes are listed below. Also, "FA computer" was globally changed to "personal computer." Pages ix, xv, 2, 3, 6, 8, 9, 11, 21, 36, 55, 106, 205, and 209: Information added for new models. Page ix: Manual added to table. Page xiii: Precaution added on utility systems. Pages 2, 3, 8, 42, 44, 47, 57, 69, 75 to 77, 143, 160, 166, 172, 178, 192, 194, 195, and 217: Diagrams modified or replaced. Pages 5 to 7, 9, 13, 39, 42, 44, 47, 50, 62, 73, 111, 113, 115, 145, 210, 211, and 225: Information on GI cable added. Page 10: Sentence added to note 2. Page 11: Heading removed and note modified. Page 16: Table and second sentence under it modified. Pages 32 and 34: Model number headings added. Pages 38, 40, and 58: Heading modified. Pages 40 to 42: Order of information changed. Page 55: Notes changed. Page 63: First paragraph in 5-2-3 modified. Pages 69 and 70: CX-Programmer added or Support Software version added. Page 80: Information added to "Communications error" description and note b removed. Page 81: Ladder diagram and accompanying description modified. Pages 85 to 90, and 98: Note at bottom of diagram (*1) changed. Page 105: Last paragraph changed. Page 106: Top graphic removed. Page 107: Status 2 description changed and note 1 changed. Page 124: Description of 22 03 to 22 06 changed. Pages 130 to 132, and 205: Notes changed. Pages 147, 151, 156, 217, 218, 222, and 223: Numeric values changed. Page 149: "Max." added twice at bottom of page. Pages 151, 153, 155, and 157: Description and table modified. Page 161: "Error information: Bit 15 ON" removed from bottom of page. Pages 163 and 169: Error codes changed. Page 189: <i>Detail code</i> descriptions changed for 0220 through 0223. Pages 190 and 216: "Information #1" and "information #2" reversed. Page 204: "Optical tester" added and table contents changed. Page 207: Description added before procedure at bottom of page. Page 208: Description added at bottom of page. Page 228: Note added and <i>Number of data link words</i> description changed. Page 229: Appendix D added.</p>

Revision History

Revision code	Date	Revised content
03	September 2002	<p>Changes were made throughout the manual, including the addition of a new section (Section 8), to provide information on new "-V1" models. This mainly consists of information relating to duplex operation and online replacement as well as information on version 3 of the CX-Programmer. "PC" was changed to "PLC" (to indicate "Programmable Controller") throughout the manual and "CS1" was changed to "CS" or omitted where appropriate. In addition, the following changes were made. Appendices A and B were interchanged.</p> <p>Pages 28 to 31: Changes made to the "Nodes" column in the tables.</p> <p>Page 32: Table added and order changed (in addition to changes mentioned above).</p> <p>Page 46: Parenthetic information on CS-series Units added in two places.</p> <p>Page 48: Wording changed to include "CS1-H" in two places.</p> <p>Page 58: Note 1 removed.</p> <p>Pages 59 and 63: Change made to Note 4.</p> <p>Page 64: Change made to information on setting the transmission path format.</p> <p>Page 65: Information on creating I/O tables added.</p> <p>Pages 75, 76: Changes made to information on first data link status word.</p> <p>Page 76: Number of EM Area banks changed from 15 to 12 in one place.</p> <p>Page 86: First note removed.</p> <p>Page 97: Information added to note. Changes made to second table.</p> <p>Page 99: Note added.</p> <p>Pages 102, 103, 104, 105, 106, 169, 190: Changes made to graphics.</p> <p>Page 112: Note removed.</p> <p>Pages 113, 114: Changes made to tables in several places.</p> <p>Page 115: Changes made to first paragraph.</p> <p>Page 116: Line added under grid.</p> <p>Page 118: 120000 changed to 121000 in one place.</p> <p>Page 119: XFER changed to @XFER.</p> <p>Page 120: 00010 changed to 00004 in one place.</p> <p>Page 124: Change made to information on version.</p> <p>Page 125: Changes made to bottom graphic.</p> <p>Page 127: 32 changed to 62 in one place.</p> <p>Page 128: Changes made to information on data link status read.</p> <p>Page 129: Information added under graphic.</p> <p>Page 130: 1 changed to 0 in one place.</p> <p>Page 140: Information added to "Probable cause" column.</p> <p>Page 141: "active" changed to "inactive" in one place.</p> <p>Page 143: Changes made to information in "Probable cause" and "Remedy" columns.</p> <p>Page 147: Information on CQM1H-series PLCs removed.</p> <p>Page 149: Changes made to first graphic.</p> <p>Page 155: # changed to 3 in one place.</p> <p>Page 162: Change made to information on specifying network parameters and note added.</p> <p>Page 163: Change made to transmission speed.</p> <p>Page 169: Changes made to calculations.</p> <p>Page 170: 7 changed to 1 in one place.</p> <p>Page 173: 62 changed to 32 in one place.</p> <p>Pages 192, 198: 1 and 2 interchanged in one place.</p> <p>Page 195: Information on power supply status removed.</p> <p>Page 205: Changes made to "Correction" column.</p> <p>Page 207: Change made to "Contents" and "1st byte" column.</p> <p>Page 215: Parenthetic information on support software changed in three places.</p> <p>Page 229: Information on CX-Programmer changed.</p> <p>Page 230: Connector model number changed in one place.</p> <p>Page 231: Assembly tool model numbers changed in four places.</p> <p>Page 233: Information added to table.</p> <p>Page 243: Changes made to second graphic.</p>

Revision History

Revision code	Date	Revised content
04	June 2003	<p>Changes were made throughout the manual, including the addition of a new section (Section 11), to provide information on new CS1W-CLK12-V1 and CS1W-CLK52-V1 models. This mainly consists of information relating to duplex operation and automatic setting of data links with 1:N allocations. In addition, the following changes were made.</p> <p>Page xv: Precautions about momentary power interruption and backup power supply added.</p> <p>Page 10: Information added on data link manual setting and automatic setting with 1:N allocations.</p> <p>Pages 15, 17: Information added on storage location of manually-set data link tables and routing tables added to table, and information added below table on models required for automatically setting data links and changing data link tables.</p> <p>Page 22: Model number of CX-Programmer changed in table, and note added below table on lot numbers of new models.</p> <p>Page 24: Note added on lot numbers of new models.</p> <p>Page 25: Model number of CX-Programmer changed in table, and note added below table on lot numbers of new models.</p> <p>Page 29: Information including a table added on communications errors.</p> <p>Page 30: Information added on lot numbers of new models</p> <p>Page 35: Table for automatic data link creation procedure changed to include new models and new tables added for procedures to set the different types of 1:N allocations.</p> <p>Page 69: Changed "0" to "-" in setting of bit 6 in software switch diagram.</p> <p>Page 77: "Equality Layout" added to heading for information on automatically setting data links.</p> <p>Page 78: Information added on automatically setting data links with 1:N allocations.</p> <p>Page 79: Note added on communications errors.</p> <p>Page 81: Information on bit settings changed in diagram for CS-series startup nodes to include automatic setting with 1:N allocations.</p> <p>Pages 94 and 95: Information added for CS-series startup nodes on automatically setting data links with 1:N allocations, including details of different types of 1:N allocations.</p> <p>Page 98: "Equality Layout" added to heading for example of automatically setting data links.</p> <p>Page 99: Information added on examples of setting DM parameters with 1:N allocations.</p> <p>Page 100: Note added on setting startup nodes in CS1D systems.</p> <p>Page 101: Information on Support Software removed from note.</p> <p>Page 103: Information added to note.</p> <p>Page 105: Bit settings changed from "0" to "-" in diagram of Local Node Data Link Participation Flags.</p> <p>Page 106: Information on data link status storage format from page 107 moved to this page with new information added. Error detection program example removed and new examples added.</p> <p>Pages 111 to 114: Changed "00" to "01" and "0" to "1" in details of bits 8 to 15 of C+2 in diagram.</p> <p>Page 134: Changed "Reserved (0)" to "Reserved" in diagram.</p> <p>Page 135: Changed diagram on bit settings to include automatic setting with 1:N allocations.</p> <p>Page 169: Note added on setting startup nodes in CS1D systems.</p> <p>Page 171: Changed "0" to "-" in setting of bit 6 in software switch diagram.</p> <p>Page 173: Step added to procedure for duplex operation and note added on setting startup nodes in CS1D systems.</p> <p>Page 178: Information added on setting startup nodes in CS1D systems.</p> <p>Page 212: Information on automatic setting with 1:N allocations added to tables.</p> <p>Pages 252 and 253: Changed "0" to "-" in setting of bit 6 in diagram.</p> <p>Page 256: Note added on setting startup nodes in CS1D systems.</p> <p>Page 262: Changed diagram on bit settings to include automatic setting with 1:N allocations.</p> <p>Page 265: Changed diagram on bit settings to include automatic setting with 1:N allocations, and added tables on parameters for automatically setting data links with 1:N allocations.</p>

Revision History

Revision code	Date	Revised content
05	August 2004	<p>Changes were made throughout the manual associated with new functionality in upgrades for Controller Link Units with unit version 1.2 or later, CX-Programmer version 5.0 or later, and CPU Units with unit version 3.0 or later, including the following changes.</p> <p>Page v: Added information on unit versions.</p> <p>Page xviii: Changed EMI standard from EN50081-2 to EN61000-6-4.</p> <p>Page 7: Added specifications for new unit versions to table and added information for data links.</p> <p>Page 9: Changed the number of network levels from three to eight and added note.</p> <p>Pages 10 and 11: Added information on lot numbers.</p> <p>Page 15: Added specifications for new unit versions to table.</p> <p>Pages 17 and 19: Removed note and changed information in diagram.</p> <p>Page 20: Added information.</p> <p>Pages 21 and 22: Changed “11” to “71” at the end of model numbers in both tables and added information to table.</p> <p>Page 24: CX-Programmer model No. changed in table and notes added and changed under table.</p> <p>Pages 26, 27, 28, and 31: Changed model number in table and added note and lot number information.</p> <p>Page 32: Added precautions.</p> <p>Page 34: Removed “SYSMAC Support Software” from table.</p> <p>Page 39: Added information on lot numbers.</p> <p>Page 59: Changed and added information.</p> <p>Pages 77, 80, 81, 103, and 256: Removed “SYSMAC Support Software” from paragraph.</p> <p>Page 84: Added information on data links and changed “Controller Link Support Software (Ver. 2.0)” to “Support Software.”</p> <p>Pages 86 and 87: Added information to note.</p> <p>Page 89: Added information to table.</p> <p>Page 94: Changed information in table and <i>Note 1</i>.</p> <p>Pages 95 and 96: Added note.</p> <p>Page 105: Added information to note.</p> <p>Page 107: Changed “IR” to “CIO” in table and changed note.</p> <p>Pages 109 and 110: Added information to table.</p> <p>Page 111: Added information to notes.</p> <p>Page 113: Changed “IR” to “CIO” in area types.</p> <p>Page 114: Added information to table and changed note.</p> <p>Page 115: Added information to note.</p> <p>Page 117: Changed “IR” to “CIO” in table, added information to table and note.</p> <p>Page 118: Added information to note.</p> <p>Page 135: Added notes.</p> <p>Pages 146 and 227: Changed reference manual.</p> <p>Page 175: Changed information in table for response code 05 04.</p> <p>Page 181: Changed information in note.</p> <p>Page 221: Changed graphic, removed “interrupt” and replaced table.</p> <p>Page 222: Changed “15 ms or 8 ms” to “25 ms” and “10 ms or 8 ms” to “10 ms” for cycle times.</p> <p>Page 223: Changed possible delay from one to “one or two cycles” and added note.</p> <p>Page 224: Changed data processing time equation and values in table.</p> <p>Pages 236 and 137: Added information to table.</p> <p>Page 260: Changed information for 0110 hex.</p> <p>Page 262: Changed information for 0216 and 021A hex and added information for 0230 hex.</p> <p>Page 263: Added note.</p> <p>Page 264: Added new sub-section <i>10-4 Troubleshooting Error Messages in CX-Net Data Link Table Check</i>.</p> <p>Pages 292 and 296: Added information to note on lot numbers.</p> <p>Page 315: Changed information for CX-Programmer</p> <p>Page 316: Changed “11” to “71” at end of model number and added models to connector table.</p> <p>Page 317: Changed “11” to “71” at end of model numbers.</p> <p>Page 318: Changed and added information on Assembly Tools.</p>

Revision History

Revision code	Date	Revised content
06	September 2007	<p>Added the CS1W-CLK13 and CS1W-CLK53 throughout the manual.</p> <p>Page vii: Updated function support table and added note 2 below the table.</p> <p>Page vii: Added version checking procedure.</p> <p>Page viii: Updated the reference manual table.</p> <p>Page xix: Added precautionary items for high-frequency noise and abnormal vibration.</p> <p>Page 6: Added note below the figure under <i>Error Log</i>.</p> <p>Page 7: Modified the table under <i>Data Links</i>.</p> <p>Page 15: Modified the table under <i>Models</i> and added note 4.</p> <p>Page 16: Changed specifications for number of data link words.</p> <p>Page 17: Changed weights in the table.</p> <p>Page 19: Changed current consumption values in the table.</p> <p>Pages 25 and 26: Changed notes.</p> <p>Page 33: Deleted and modified a couple of paragraphs.</p> <p>Page 37: Changed note d.</p> <p>Page 39: Changed note c.</p> <p>Page 79: Deleted the last sentence from note 5.</p> <p>Page 83: Deleted the last sentence from note 4.</p> <p>Page 86: Modified the table under <i>Functions by Unit Version</i> and added a note below the table.</p> <p>Page 92: Changed description for number of data link words in the top table and changed notes below the table.</p> <p>Page 94: Added a note under <i>CVM1 and CV-series Startup Nodes</i>.</p> <p>Page 111: Changed notes below the table.</p> <p>Page 160: Changed the paragraph under 6-4-1 and 6-4-3 regarding reference manuals.</p> <p>Page 163: Changed description under <i>Version and Connection Method</i>.</p> <p>Page 174: Changed description and added a table under <i>Number of stored records</i>.</p> <p>Page 189: Added notes below the bottom figure.</p> <p>Page 200: Modified the figure and deleted one table row.</p> <p>Page 201: Changed the note at the top of the page and specifications in the table.</p> <p>Page 202: Modified the table and note below the table.</p> <p>Page 204: Changed note 4.</p> <p>Page 209: Changed the third paragraph from the bottom.</p> <p>Page 209: Changed the third paragraph from the bottom.</p> <p>Page 210: Deleted the top paragraph and the table.</p> <p>Pages 213 and 214: Changed description of A261 bits 11 and 12, A434, and A435</p> <p>Page 227: Changed note.</p> <p>Page 260: Added "a maximum of 64 records" to the paragraphs and table under <i>Error Log Table</i>. Changed note.</p> <p>Pages 265, 266, and 267: Added note to EEPROM column and changed note below the table.</p> <p>Page 269: Added one column for node size.</p> <p>Page 278: Changed the third paragraph regarding the use of Support Software.</p> <p>Page 280: Changed text boxes in the figure.</p> <p>Page 289: Added version upgrade information.</p> <p>Page 289: Deleted the first paragraph under <i>Setting the Transmission Format</i>.</p> <p>Pages 299 and 301: Added one note.</p> <p>Page 303: Deleted the second paragraph from the top.</p> <p>Page 325: Deleted information on <i>Optical Fiber Cables with Connectors</i>.</p>
07	June 2008	<p>Page xvii: Added information on warranty and applicability.</p> <p>Pages 250, 257, 267, 273, 278, 282, 314, and 320: Added " and Local Node Disconnection Flag status."</p>

OMRON Corporation
Industrial Automation Company
Control Devices Division H.Q.
PLC Division

Shiokoji Horikawa, Shimogyo-ku,
Kyoto, 600-8530 Japan
Tel: (81) 75-344-7084/Fax: (81) 75-344-7149

Regional Headquarters

OMRON EUROPE B.V.
Wegalaan 67-69-2132 JD Hoofddorp
The Netherlands
Tel: (31)2356-81-300/Fax: (31)2356-81-388

OMRON Industrial Automation Global: www.ia.omron.com

OMRON ELECTRONICS LLC

One Commerce Drive Schaumburg,
IL 60173-5302 U.S.A.
Tel: (1) 847-843-7900/Fax: (1) 847-843-7787

OMRON ASIA PACIFIC PTE. LTD.

No. 438A Alexandra Road # 05-05/08 (Lobby 2),
Alexandra Technopark, Singapore 119967
Tel: (65) 6835-3011/Fax: (65) 6835-2711

OMRON (CHINA) CO., LTD.

Room 2211, Bank of China Tower,
200 Yin Cheng Zhong Road,
PuDong New Area, Shanghai, 200120, China
Tel: (86) 21-5037-2222/Fax: (86) 21-5037-2200

Authorized Distributor:

© OMRON Corporation 2000 All Rights Reserved.
In the interest of product improvement,
specifications are subject to change without notice.

Cat. No. W370-E1-07

Printed in Japan
0608